



**RURAL ELECTRIFICATION & RENEWABLE
ENERGY CORPORATION**

**KAWI HOUSE, SOUTH C,
P.O. Box 34585, 00100
Nairobi, Kenya
e-mail: info@rea.co.ke; procurement@rea.co.ke;
TEL NO.254-20-2710955/2713921**

INVITATION TO TENDER RFX No. 1000001578

**TENDER NAME; MANDA ISLAND 11KV DOUBLE CIRCUIT
POWER LINE OCEAN CHANNEL CROSSING & ASSOCIATED
WORKS (RETENDER).**

(E-Procurement System)

VOLUME 1

May 2026

Contents

TENDER NAME; MANDA ISLAND 11KV DOUBLE CIRCUIT POWER LINE OCEAN CHANNEL CROSSING & ASSOCIATED WORKS (RETENDER).	1
INVITATION TO TENDER (ITT) PROCURING ENTITY:	3
SECTION II - TENDER DATA SHEET	24
Part III – Financial Evaluation.....	40
*NOTES: -	40
1.1 Nationality	43
1.2 Conflict of Interest.....	43
1.3 PPRA Ineligibility (if debarred/Sanctioned)	43
1.4 State Owned Enterprise or Institution	43
1.5 Ineligibility based on a United Nations resolution or Kenya laws	43
1.6 Tax Obligations for Kenyan Tenderers.....	43
No.....	60
Name of Contract	60
Procuring Entity's	60
(Amended and issued pursuant to PPRA CIRCULAR No. 02/2022).....	67
TENDERER'S ELIGIBILITY - CONFIDENTIAL BUSINESS QUESTIONNAIRE.....	70
CERTIFICATE OF INDEPENDENT TENDER DETERMINATION.....	73
SELF DECLARATION FORMS.....	75
FORM SD1	75
FORM SD2	76
PART II - WORKS REQUIREMENTS.....	85
Schedule No. 2 - Reinforced Concrete Cable Trench and 150mm PVC Ducts for Road Crossing.....	93
Schedule No. 3 - Supply and Installation of 18m Concrete Poles with Reinforced Concrete Pole Socket Mounting.....	95
Total Schedule No. 2. Reinforced Concrete Cable Trench and 150mm PVC Ducts for Road Crossing.....	105
APPENDIX 9.A1	124
5. TOWERS.....	126
6. CIVIL WORKS.....	135
SECTION VIII - CONTRACT FORMS	226
FORM NO. 5 PERFORMANCE SECURITY FORM.....	234
FORM No. 6- PERFORMANCE SECURITY OPTION 2 – (Performance Bond)	236
FORM NO. 7 ADVANCE PAYMENT SECURITY - Demand Bank Guarantee	238
FORM NO. 9 BENEFICIAL OWNERSHIP DISCLOSURE FORM.....	240
(Amended and issued pursuant to PPRA CIRCULAR No. 02/2022).....	240

INVITATION TO TENDER (ITT) PROCURING ENTITY:

Rural Electrification Authority and Renewable Energy Corporation Kawi Complex,
South C,

Kawi House – South C, off Red Cross Road.
P.O. BOX 34585 -00100

NAIROBI, KENYA

TENDER NUMBER RFX 1000001578

CONTRACT NAME AND DESCRIPTION: Manda Island 11kv Double Circuit Power Line Ocean Channel Crossing & Associated Works (Retender).

1. Rural Electrification and Renewable Energy Corporation invites sealed tenders for procurement of Manda Island 11kv Double Circuit Power Line Ocean Channel Crossing & Associated Works (Retender).
2. Tendering will be conducted under open competitive method National tender using a standardized tender document. Tendering is open to all qualified and interested Tenderers.
3. Qualified interested tenderers may obtain further information during office 8.00am - 12.45pm to 1.45pm – 4.00pm Monday to Friday at the address given below.
4. A complete set of tender documents may be viewed and downloaded by interested tenderers free of charge electronically from the Website www.rerec.co.ke under tender documents or through the e-procurement portal using <https://suppliers.rea.co.ke:44300/irj/portal>

Tenderers who are not yet registered with REREC must register their companies in order to participate in the tender using link below that can be found from the website www.rerec.co.ke Procurement-Supplier registration:[https://suppliers.rea.co.ke:44200/supportal\(bD1IbiZjPTUwMCZkPW1pbg==\)/bspwdapplication.do#VIEW ANCHOR-ROS TOP](https://suppliers.rea.co.ke:44200/supportal(bD1IbiZjPTUwMCZkPW1pbg==)/bspwdapplication.do#VIEW_ANCHOR-ROS_TOP)

5. Tender documents may be viewed and downloaded for free from the website www.rerec.co.ke Tenderers who download the tender document must forward their particulars immediately to tenders@rerec.co.ke to facilitate any further clarification or addendum.
6. All Tenders must be accompanied by a tender Security in form of a bank guarantee for amount Kshs 5,800,000

7. The Tenderer shall chronologically serialize all pages of the tender documents submitted.
8. Completed tenders must be delivered to Rural Electrification and Renewable Energy Corporation electronically through <https://suppliers.rea.co.ke:44300/irj/portal> on or before **03th July, 2026 at 10am**
9. The deadline date and time specified above or any dead line date and time specified later. Tenders will be publicly opened in the presence of the Tenderers' designated representatives and anyone who chooses to attend at the address below.
10. Late tenders will be rejected.
11. The addresses referred to above are:

A. **Address for obtaining further information**

Chief Executive Officer

Rural Electrification Authority and Renewable Energy Corporation Kawi Complex, South C,

Kawi House – South C, off Red Cross Road.

P.O. BOX 34585 -00100

NAIROBI, KENYA

Telephone: + 254 709 193000

Email: info@rerec.co.ke

tenders@rerec.co.ke

B. **Address for Submission of Tenders.**

Address for Submission of Tenders: Online Through
<https://suppliers.rea.co.ke:44300/irj/portal>

Address for Opening of Tenders. Kawi Complex, Block C, Ground floor, online system

PART 1 - TENDERING PROCEDURES

SECTION I - INSTRUCTIONS TO

TENDERERS

A GENERAL PROVISIONS

1.0 Scope of tender

1.1 The Procuring Entity as defined in the Appendix to Conditions of Contract invites tenders for Works Contract as described in the tender documents. The name, identification, and number of lots (contracts) of this Tender Document are specified in the TDS.

1.2 Throughout this tendering document:

- a) The term “inwriting” means communicated in written form (e.g. by mail, e-mail, fax, including if specified in the TDS, distributed or received through the electronic-procurement system used by the Procuring Entity) with proof of receipt;
- b) if the context so requires, “singular” means “plural” and vice versa;
- c) “Day” means calendar day, unless otherwise specified as “Business Day”. A Business Day is any day that is an official working day of the Procuring Entity. It excludes official public holidays.

2.0 Fraud and corruption

2.1 The Procuring Entity requires compliance with the provisions of the Public Procurement and Asset Disposal Act, 2015, Section 62 “Declaration not to engage in corruption”. The tender submitted by a person shall include a declaration that the person shall not engage in any corrupt or fraudulent practice and a declaration that the person or his or her sub-contractors are not debarred from participating in public procurement proceedings.

2.2 The Procuring Entity requires compliance with the provisions of the Competition Act 2010, regarding collusive practices in contracting. Any tenderer found to have engaged in collusive conduct shall be disqualified and criminal and/or civil sanctions may be imposed. To this effect, Tenders shall be required to complete and sign the “Certificate of Independent Tender Determination” annexed to the Form of Tender.

2.3 Tenderers shall permit and shall cause their agents (whether declared or not), subcontractors, sub-consultants, service providers, suppliers, and their personnel, to permit the Procuring Entity to inspect all accounts, records and other documents relating to any initial selection process, pre-qualification process, tender submission, proposal submission, and contract performance (in the case of award), and to have them audited by auditors appointed by the Procuring Entity.

2.4 Unfair Competitive Advantage - Fairness and transparency in the tender process require that the firms or their Affiliates competing for a specific assignment do not derive a competitive advantage from having provided consulting services related to this tender. To that end, the Procuring Entity shall indicate in the **Data Sheet** and make available to all the firms together with this tender document all information that would in that respect give such firm any unfair competitive advantage over competing firms.

3.0 Eligible tenderers

3.1 A Tenderer may be a firm that is a private entity, a state-owned enterprise or institution subject to ITT 3.8, or an individual or any combination of such entities in the form of a joint venture (JV) under an existing agreement with the intent to enter into such an agreement supported by a letter of intent. In the case of a joint venture, all members shall be jointly and severally liable for the execution of the entire Contract in accordance with the Contract terms. The JV shall nominate a Representative who shall have the authority to conduct all business for and on behalf of any and all the members of the JV during the tendering process and, in the event the

JV is awarded the Contract, during contract execution. Members of a joint venture may not also make an individual tender, be a subcontractor in a separate tender or be part of another joint venture for the purposes of the same Tender. The maximum number of JV members shall be specified in the TDS.

- 3.2** Public Officers of the Procuring Entity, their Spouses, Child, Parent, Brothers or Sister. Child, Parent, Brother or Sister of a Spouse, their business associates or agents and firms/organizations in which they have a substantial or controlling interest shall not be eligible to tender or be awarded a contract. Public Officers are also not allowed to participate in any procurement proceedings.
- 3.3** A Tenderer shall not have a conflict of interest. Any tenderer found to have a conflict of interest shall be disqualified. A tenderer may be considered to have a conflict of interest for the purpose of this tendering process, if the tenderer:
- a) Directly or indirectly controls, is controlled by or is under common control with an other tenderer;
 - b) Receives or has received any director indirect subsidy from another tenderer;
 - c) Has the same legal representative as an other tenderer;
 - d) Has a relationship with an other tenderer, directly or through common third parties, that puts it in a position to influence the tender of an other tenderer, or influence the decisions of the Procuring Entity regarding this tendering process;
 - e) Any of its affiliates participated as a consultant in the preparation of the design or technical specifications of the goods or works that are the subject of the tender;
 - f) Any of its affiliates has been hired (or is proposed to be hired) by the Procuring Entity as a consultant for Contract implementation;
 - g) Would be providing goods, works, or non-consulting services resulting from or directly related to consulting services for the preparation or implementation of the contract specified in this Tender Document;
 - h) Has a close business or personal relationship with senior management or professional staff of the Procuring Entity who has the ability to influence the bidding process and:
 - i) Are directly or indirectly involved in the preparation of the Tender document or specifications of the Contract, and/or the Tender evaluation process of such contract; or
 - ii) May be involved in the implementation or supervision of such Contract unless the conflicts stemming from such relationship has been resolved in a manner acceptable to the Procuring Entity throughout the tendering process and execution of the Contract.
- 3.4** A tenderer shall not be involved in corrupt, coercive, obstructive or fraudulent practice. A tenderer that is proven to have been involved in any of these practices shall be automatically disqualified
- 3.5** A Tenderer (either individually or as a JV member) shall not participate in more than one Tender, except for permitted alternative tenders. This includes participation as a subcontractor in other Tenders. Such participation shall result in the disqualification of all Tenders in which the firm is involved. Members of a joint venture may not also make an individual tender, be a sub-contractor in a separate tender or be part of another joint venture for the purposes of the same Tender. A firm that is not a tenderer or a JV member may participate as a subcontractor in more than one tender.
- 3.6** A Tenderer may have the nationality of any country, subject to the restrictions pursuant to ITT3.9. A Tenderer shall be deemed to have the nationality of a country if the Tenderer is constituted, incorporated or registered in and operates in conformity with the provisions of the laws of that country, as evidenced by its articles of incorporation (or equivalent documents of constitution or association) and its registration documents, as the case may be. This criterion also shall apply to the determination of the nationality of proposed sub-contractors or sub-consultants for any part of the Contract including related Services.

- 3.7** A Tenderer that has been debarred from participating in public procurement shall be ineligible to tender or be awarded a contract. The list of debarred firms and individuals is available from the website of PPRRA www.ppra.go.ke.
- 3.8** A Tenderer that is a state-owned enterprise or a public institution in Kenya may be eligible to tender and be awarded Contract(s) only if it is determined by the Procuring Entity to meet the following conditions, i.e. if it is:
- i) A legal public entity of Government and/or public administration,
 - ii) financially autonomous and not receiving any significant subsidies or budget support from any public entity or Government, and;
 - (iii) operating under commercial law and vested with legal rights and liabilities similar to any commercial enterprise to enable it to compete with firms in the private sector on an equal basis.
- 3.9** Firms and individuals shall be ineligible if their countries of origin are:
- (a) As a matter of law or official regulations, Kenya prohibits commercial relations with that country;
 - (b) by an act of compliance with a decision of the United Nations Security Council taken under Chapter VII of the Charter of the United Nations, Kenya prohibits any import of goods or contracting of works or services from that country, or any payments to any country, person, or entity in that country.
- A tenderer shall provide such documentary evidence of eligibility satisfactory to the Procuring Entity, as the Procuring Entity shall reasonably request.
- 3.10** Foreign tenderers are required to source at least forty (40%) percent of their contract inputs (in supplies, local sub-contracts and labor) from citizen suppliers and contractors. To this end, a foreign tenderer shall provide in its tender documentary evidence that this requirement is met. Foreign tenderers not meeting this criterion will be automatically disqualified. Information required to enable the Procuring Entity determine if this condition is met shall be provided for this purpose in *“SECTION II - EVALUATION AND QUALIFICATION CRITERIA, Item 9”*.
- 3.11** Pursuant to the eligibility requirements of ITT 3.10, a tender is considered a foreign tenderer, If it is registered in Kenya and has less than 51 percent ownership by nationals of Kenya and if it does not subcontract to foreign firms or individuals more than 10 percent of the contract price, excluding provisional sums. JVs are considered as foreign tenderers if the individual member firms registered in Kenya have less 51 percent ownership by nationals of Kenya. The JV shall not subcontract to foreign firms more than 10 percent of the contract price, excluding provisional sums.
- 3.12** The National Construction Authority Act of Kenya requires that all local and foreign contractors be registered with the National Construction Authority and be issued with a Registration Certificate before they can undertake any construction works in Kenya. Registration shall not be a condition for tender, but it shall be a condition of contract award and signature. A selected tenderer shall be given opportunity to register before such award and signature of contract. Application for registration with National Construction Authority may be accessed from the website www.nca.go.ke.
- 3.13** The Competition Act of Kenya requires that firms wishing to tender as Joint Venture undertakings which may prevent, distort or lessen competition in provision of services are prohibited unless they are exempt in accordance with the provisions of Section 25 of the Competition Act, 2010. JVs will be required to seek for exemption from the Competition Authority. Exemption shall not be a condition for tender, but it shall be a condition of contract award and signature. A JV tenderer shall be given opportunity to seek such exemption as a condition of award and signature of contract. Application for exemption from the Competition Authority of Kenya may be accessed from the website www.cak.go.ke.
- 4.14** A Kenyan tenderer shall be eligible to tender if it provides evidence of having fulfilled his/her tax obligations by producing valid tax compliance certificate or tax exemption certificate issued by the Kenya Revenue Authority.
- 4.0** *Eligible goods, equipment, and services*
- 4.1** Goods, equipment and services to be supplied under the Contract may have their origin in any

country that is not ineligible under ITT 3.9. At the Procuring Entity's request, Tenderers may be required to provide evidence of the origin of Goods, equipment and services.

- 4.2 Any goods, works and production processes with characteristics that have been declared by the relevant national environmental protection agency or by other competent authority as harmful to human beings and to the environment shall not be eligible for procurement.

5.0 *Tenderer's responsibilities*

- 5.1 The tenderer shall bear all costs associated with the preparation and submission of his/her tender, and the Procuring Entity will in no case be responsible or liable for those costs.
- 5.2 The tenderer, at the tenderer's own responsibility and risk, is encouraged to visit and examine and inspect the Site of the Works and its surroundings and obtain all information that may be necessary for preparing the tender and entering into a contract for construction of the Works. The costs of visiting the Site shall be the tenderer's own expense.
- 5.3 The Tenderer and any of its personnel or agents will be granted permission by the Procuring Entity to enter upon its premises and lands for the purpose of such visit. The Tenderer shall indemnify the Procuring Entity against liability arising from death or personal injury, loss of or damage to property, and any other losses and expenses incurred as a result of the examination and inspection.
- 5.4 The tenderer shall provide in the Form of Tender and Qualification Information, a preliminary description of the proposed work method and schedule, including charts, as necessary or required.

B. CONTENTS OF TENDER DOCUMENTS

6.0 *Sections of Tender Document*

- 6.1 The tender document consists of Parts 1, 2, and 3, which includes all the sections specified below, and which should be read in conjunction with any Addenda issued in accordance with ITT 10.

PART 1: Tendering Procedures

Section I – Instructions to Tenderers
Section II – Tender Data Sheet (TDS)
Section III- Evaluation and
Qualification Criteria Section IV –
Tendering Forms

PART 2: Works'

Requirements Section
V - Bills of Quantities
Section VI -
Specifications Section
VII - Drawings

PART 3: Conditions of Contract and Contract Forms

Section VIII - General Conditions (GCC)
Section IX - Special Conditions of Contract
Section X- Contract Forms

- 6.2 The Invitation to Tender Notice issued by the Procuring Entity is not part of the Contract documents. Unless obtained directly from the Procuring Entity, the Procuring Entity is not responsible for the completeness of the Tender document, responses to requests for clarification, the minutes of a pre-arranged site visit and those of the pre-Tender meeting (if any), or Addenda to the Tender document in accordance with ITT 10. In case of any contradiction, documents obtained directly from the Procuring Entity shall prevail.

6.3 The Tenderer is expected to examine all instructions, forms, terms, and specifications in the Tender Document and to furnish with its Tender all information and documentation as is required by the Tender document.

7.0 *Clarification of Tender Document, Site Visit, Pre-tender Meeting*

7.1 A Tenderer requiring any clarification of the Tender Document shall contact the Procuring Entity in writing at the Procuring Entity's address specified in the **TDS** or raise its enquiries during the pre-Tender meeting if provided for in accordance with ITT 7.2. The Procuring Entity will respond in writing to any request for clarification, provided that such request is received no later than the period specified in the **TDS** prior to the deadline for submission of tenders. The Procuring Entity shall forward copies of its response to all tenderers who have acquired the Tender documents in accordance with ITT 7.4, including a description of the inquiry but without identifying its source. If so specified in the **TDS**, the Procuring Entity shall also promptly publish its response at the web page identified in the **TDS**. Should the clarification result in changes to the essential elements of the Tender Documents, the Procuring Entity shall amend the Tender Documents following the procedure under ITT 8 and ITT 22.2.

7.2 The Tenderer, at the Tenderer's own responsibility and risk, is encouraged to visit and examine and inspect the site(s) of the required contracts and obtain all information that may be necessary for preparing a tender. The costs of visiting the Site shall be at the Tenderer's own expense. The Procuring Entity shall specify in the **TDS** if a pre-arranged Site visit and or a pre-tender meeting will be held, when and where. The Tenderer's designated representative is invited to attend a pre-arranged site visit and a pre-tender meeting, as the case may be. The purpose of the site visit and the pre-tender meeting will be to clarify issues and to answer questions on any matter that may be raised at that stage.

7.3 The Tenderer is requested to submit any questions in writing, to reach the Procuring Entity not later than the period specified in the **TDS** before the meeting.

7.4 Minutes of a pre-arranged site visit and those of the pre-tender meeting, if applicable, including the text of the questions asked by Tenderers and the responses given, together with any responses prepared after the meeting, will be transmitted promptly to all Tenderers who have acquired the Tender Documents. Minutes shall not identify the source of the questions asked.

7.5 The Procuring Entity shall also promptly publish anonymized (*no names*) Minutes of the pre-arranged site visit and those of the pre-tender meeting at the web page identified in the **TDS**. Any modification to the Tender Documents that may become necessary as a result of the pre-arranged site visit and those of the pre-tender meeting shall be made by the Procuring Entity exclusively through the issue of an Addendum pursuant to ITT 8 and not through the minutes of the pre-Tender meeting. Non-attendance at the pre-arranged site visit and the pre-tender meeting will not be a cause for disqualification of a Tenderer.

8.0 *Amendment of Tender Documents*

8.1 At any time prior to the deadline for submission of Tenders, the Procuring Entity may amend the Tender Documents by issuing addenda.

8.2 Any addendum issued shall be part of the Tender Documents and shall be communicated in writing to all who have obtained the Tender Documents from the Procuring Entity. The Procuring Entity shall also promptly publish the addendum on the Procuring Entity's website in accordance with ITT 7.5.

8.3 To give Tenderers reasonable time in which to take an addendum into account in preparing their Tenders, the Procuring Entity should extend the dead line for the submission of Tenders,

pursuant to ITT 22.2.

C. PREPARATION OF TENDERS

9. Cost of Tendering

The Tenderer shall bear all costs associated with the preparation and submission of its Tender, and the Procuring Entity shall not be responsible or liable for those costs, regardless of the conduct or outcome of the tendering process.

10.0 *Language of Tender*

The Tender, as well as all correspondence and documents relating to the tender exchanged by the tenderer and the Procuring Entity, shall be written in the English Language. Supporting documents and printed literature that are part of the Tender may be in another language provided they are accompanied by an accurate and notarized translation of the relevant passages into the English Language, in which case, for purposes of interpretation of the Tender, such translation shall govern.

11.0 *Documents Comprising the Tender*

11.1 The Tender shall comprise the following:

- a) Form of Tender prepared in accordance with ITT 12;
- b) Schedules including priced Bill of Quantities, completed in accordance with ITT 12 and ITT 14;
- c) Tender Security or Tender-Securing Declaration, in accordance with ITT 19.1;
- d) Alternative Tender, if permissible, in accordance with ITT 13;
- e) **Authorization:** written confirmation authorizing the signatory of the Tender to commit the Tenderer, in accordance with ITT 20.3;
- f) **Qualifications:** documentary evidence in accordance with ITT 17 establishing the Tenderer's qualifications to perform the Contract if its Tender is accepted;
- g) **Conformity:** a technical proposal in accordance with ITT 16;
- h) Any other document required in the TDS.

11.2 In addition to the requirements under ITT 11.1, Tenders submitted by a JV shall include a copy of the Joint Venture Agreement entered into by all members. Alternatively, a letter of intent to execute a Joint Venture Agreement in the event of a successful Tender shall be signed by all members and submitted with the Tender, together with a copy of the proposed JV Agreement. Change of membership and conditions of the JV prior to contract signature will render the tender liable for disqualification.

12.0 *Form of Tender and Schedules*

12.1 The Form of Tender and Schedules, including the Bill of Quantities, shall be prepared using the relevant forms furnished in Section IV, Tendering Forms. The forms must be completed without any alterations to the text, and no substitutes shall be accepted except as provided under ITT 20.3. All blank spaces shall be filled in with the information requested. The Tenderer shall chronologically serialize all pages of the tender documents submitted.

12.2 The Tenderer shall furnish in the Form of Tender information on commissions and gratuities, if any, paid or to be paid to agents or any other party relating to this Tender.

13. *Alternative Tenders*

13.1 Unless otherwise specified in the TDS, alternative Tenders shall not be considered.

13.2 When alternative times for completion are explicitly invited, a statement to that effect will be included in the TDS, and the method of evaluating different alternative times for completion

will be described in Section III, Evaluation and Qualification Criteria.

- 133 Except as provided under ITT 13.4 below, Tenderers wishing to offer technical alternatives to the requirements of the Tender Documents must first price the Procuring Entity's design as described in the Tender Documents and shall further provide all information necessary for a complete evaluation of the alternative by the Procuring Entity, including drawings, design calculations, technical specifications, breakdown of prices, and proposed construction methodology and other relevant details. Only the technical alternatives, if any, of the Tenderer with the Winning Tender conforming to the basic technical requirements shall be considered by the Procuring Entity.
- 134 When specified in the **TDS**, Tenderers are permitted to submit alternative technical solutions for specified parts of the Works, and such parts will be identified in the **TDS**, as will the method for their evaluating, and described in Section VII, Works' Requirements.

14.0 *Tender Prices and Discounts*

- 14.1 The prices and discounts (including any price reduction) quoted by the Tenderer in the Form of Tender and in the Bill of Quantities shall conform to the requirements specified below.
- 14.2 The Tenderer shall fill in rates and prices for all items of the Works described in the Bill of Quantities. Items against which no rate or price is entered by the Tenderer shall be deemed covered by the rates for other items in the Bill of Quantities and will not be paid for separately by the Procuring Entity. An item not listed in the priced Bill of Quantities shall be assumed to be not included in the Tender, and provided that the Tender is determined substantially responsive notwithstanding this omission, the average price of the item quoted by substantially responsive Tenderers will be added to the Tender price and the equivalent total cost of the Tender so determined will be used for price comparison.
- 14.3 The price to be quoted in the Form of Tender, in accordance with ITT 12.1, shall be the total price of the Tender, including any discounts offered.
- 14.4 The Tenderer shall quote any discounts and the methodology for their application in the Form of Tender, in accordance with ITT 12.1.
- 14.5 It will be specified in the **TDS** if the rates and prices quoted by the Tenderer are or are not subject to adjustment during the performance of the Contract in accordance with the provisions of the Conditions of Contract, except in cases where the contract is subject to fluctuations and adjustments, not fixed price. In such a case, the Tenderer shall furnish the indices and weightings for the price adjustment formulae in the Schedule of Adjustment Data and the Procuring Entity may require the Tenderer to justify its proposed indices and weightings.
- 14.6 Where tenders are being invited for individual lots (contracts) or for any combination of lots (packages), tenderers wishing to offer discounts for the award of more than one Contract shall specify in their Tender the price reductions applicable to each package, or alternatively, to individual Contracts within the package. Discounts shall be submitted in accordance with ITT 14.4, provided the Tenders for all lots (contracts) are opened at the same time.
- 14.7 All duties, taxes, and other levies payable by the Contractor under the Contract, or for any other cause, as of the date 30 days prior to the deadline for submission of Tenders, shall be included in the rates and prices and the total Tender Price submitted by the Tenderer.

15.0 *Currencies of Tender and Payment*

- 15.1 The currency(ies) of the Tender and the currency(ies) of payments shall be the same.
- 15.2 Tenderers shall quote entirely in Kenya Shillings. The unit rates and the prices shall be quoted by the Tenderer in the Bill of Quantities, entirely in Kenya shillings.
- a) A Tenderer expecting to incur expenditures in other currencies for inputs to the Works supplied from outside Kenya (referred to as "the foreign currency requirements") shall (if so allowed in the **TDS**) indicate in the Appendix to Tender the percentage(s) of the Tender Price (excluding Provisional Sums), needed by the Tenderer for the payment of such foreign

currency requirements, limited to no more than two foreign currencies.

- b) The rates of exchange to be used by the Tenderer in arriving at the local currency equivalent and the percentage(s) mentioned in (a) above shall be specified by the Tenderer in the Appendix to Tender and shall be based on the exchange rate provided by the Central Bank of Kenya on the date 30 days prior to the actual date of tender opening. Such exchange rate shall apply for all foreign payments under the Contract.

15.3 Tenderers may be required by the Procuring Entity to justify, to the Procuring Entity's satisfaction, their local and foreign currency requirements, and to substantiate that the amounts included in the unit rates and prices and shown in the Schedule of Adjustment Data in the Appendix to Tender are reasonable, in which case a detailed break down of the foreign currency requirements shall be provided by Tenderers.

16.0 Documents Comprising the Technical Proposal

The Tenderer shall furnish a technical proposal including a statement of work methods, equipment, personnel, schedule and any other information as stipulated in Section IV, Tender Forms, insufficient detail to demonstrate the adequacy of the Tenderer's proposal to meet the work's requirements and the completion time.

17.0 Documents Establishing the Eligibility and Qualifications of the Tenderer

17.1 Tenderers shall complete the Form of Tender, included in Section IV, Tender Forms, to establish Tenderer's eligibility in accordance with ITT 4.

17.2 In accordance with Section III, Evaluation and Qualification Criteria, to establish its qualifications to perform the Contract the Tenderer shall provide the information requested in the corresponding information sheets included in Section IV, Tender Forms.

17.3 If a margin of preference applies as specified in accordance with ITT 33.1, national tenderers, individually or in joint ventures, applying for eligibility for national preference shall supply all information required to satisfy the criteria for eligibility specified in accordance with ITT 33.1.

17.4 Tenderers shall be asked to provide, as part of the data for qualification, such information, including details of ownership, as shall be required to determine whether, according to the classification established by the Procuring Entity, a particular contractor or group of contractors qualifies for a margin of preference. Further the information will enable the Procuring Entity identify any actual or potential conflict of interest in relation to the procurement and/or contract management processes, or a possibility of collusion between tenderers, and thereby help to prevent any corrupt influence in relation to the procurement process or contract management.

17.5 The purpose of the information described in ITT 17.4 above overrides any claims to confidentiality which a tenderer may have. There can be no circumstances in which it would be justified for a tenderer to keep information relating to its ownership and control confidential where it is tendering to undertake public sector work and receive public sector funds. Thus, confidentiality will not be accepted by the Procuring Entity as a justification for a Tenderer's failure to disclose, or failure to provide required information on its ownership and control.

17.6 The Tenderer shall provide further documentary proof, information or authorizations that the Procuring Entity may request in relation to ownership and control which information on any changes to the information which was provided by the tenderer under ITT 6.4. The obligations to require this information shall continue for the duration of the procurement process and contract performance and after completion of the contract, if any change to the information previously provided may reveal a conflict of interest in relation to the award or management of the contract.

17.7 All information provided by the tenderer pursuant to these requirements must be complete, current and accurate as at the date of provision to the Procuring Entity. In submitting the information required pursuant to these requirements, the Tenderer shall warrant that the information submitted is complete, current and accurate as at the date of submission to the Procuring Entity.

17.8 If a tenderer fails to submit the information required by these requirements, its tender will be rejected. Similarly, if the Procuring Entity is unable, after taking reasonable steps, to verify to a

reasonable degree the information submitted by a tenderer pursuant to these requirements, then the tender will be rejected.

- 17.9** If information submitted by a tenderer pursuant to these requirements, or obtained by the Procuring Entity (whether through its own enquiries, through notification by the public or otherwise), shows any conflict of interest which could materially and improperly benefit the tenderer in relation to the procurement or contract management process, then:
- i) If the procurement process is still ongoing, the tenderer will be disqualified from the procurement process,
 - ii) if the contract has been awarded to that tenderer, the contract award will be set aside depending on the outcome of (iii),
 - iii) the tenderer will be referred to the relevant law enforcement authorities for investigation of whether the tenderer or any other person has committed any criminal offence.
- 17.10** If a tenderer submits information pursuant to these requirements that is incomplete, inaccurate or out-of-date, or attempts to obstruct the verification process, then the consequences of ITT 17.8 will ensue unless the tenderer can show to the reasonable satisfaction of the Procuring Entity that any such act was not material, or was due to genuine error which was not attributable to the intentional act, negligence or recklessness of the tenderer.

18.0 Period of Validity of Tenders

- 18.1.** Tenders shall remain valid for the Tender Validity period specified in the **TDS**. The Tender Validity period starts from the date fixed for the Tender submission deadline (as prescribed by the Procuring Entity in accordance with ITT 22). A tender valid for a shorter period shall be rejected by the Procuring Entity as non-responsive.
- 18.2** In exceptional circumstances, prior to the expiration of the Tender validity period, the Procuring Entity may request Tenderers to extend the period of validity of their Tenders. The request and the responses shall be made in writing. If a Tender Security is requested in accordance with ITT 19, it shall also be extended for thirty (30) days beyond the deadline of the extended validity period. A Tenderer may refuse the request without forfeiting its Tender security. A Tenderer granting the request shall not be required or permitted to modify its Tender.

19.0 Tender Security

- 19.1** The Tenderer shall furnish as part of its Tender, either a Tender-Securing Declaration or a Tender Security as specified in the **TDS**, in original form and, in the case of a Tender Security, in the amount and currency specified in the **TDS**. A Tender-Securing Declaration shall use the form included in Section IV, Tender Forms.
- 19.2** If a Tender Security is specified pursuant to ITT 19.1, the Tender Security shall be a demand guarantee in any of the following forms at the Tenderer's option:
- i) cash;
 - ii) a bank guarantee;
 - iii) a guarantee by an insurance company registered and licensed by the Insurance Regulatory Authority listed by the Authority;
 - (iv) a guarantee issued by a financial institution approved and licensed by the Central Bank of Kenya, from a reputable source, and an eligible country.
- 19.3** If an unconditional bank guarantee is issued by a bank located outside Kenya, the issuing bank shall have a correspondent bank located in Kenya to make it enforceable. The Tender Security shall be valid for thirty (30) days beyond the original validity period of the Tender, or beyond any period of extension if requested under ITT 18.2.
- 19.4** If a Tender Security or Tender-Securing Declaration is specified pursuant to ITT 19.1, any Tender not accompanied by a substantially responsive Tender Security or Tender-Securing Declaration shall be rejected by the Procuring Entity as non-responsive.

- 19.5** If a Tender Security is specified pursuant to ITT 19.1, the Tender Security of unsuccessful Tenderers shall be returned as promptly as possible upon the successful Tenderer's signing the Contract and furnishing the Performance Security and any other documents required in the TDS. The Procuring Entity shall also promptly return the tender security to the tenderers where the procurement proceedings are terminated, all tenders were determined non-responsive or a bidder declines to extend tender validity period.
- 19.6** The Tender Security of the successful Tenderer shall be returned as promptly as possible once the successful Tenderer has signed the Contract and furnished the required Performance Security, and any other documents required in the TDS.
- 19.7** The Tender Security may be forfeited or the Tender-Securing Declaration executed:
- a) if a Tenderer withdraws its Tender during the period of Tender validity specified by the Tenderer on the Form of Tender, or any extension there to provided by the Tenderer; or
 - b) if the successful Tenderer fails to:
 - i) sign the Contract in accordance with ITT 4.7; or
 - ii) furnish a Performance Security and if required in the TDS, and any other documents required in the TDS.
- 19.8** Where tender securing declaration is executed, the Procuring Entity shall recommend to the PPRA to debar the Tenderer from participating in public procurement as provided in the law.
- 19.9** The Tender Security or the Tender-Securing Declaration of a JV shall be in the name of the JV that submits the Tender. If the JV has not been legally constituted into a legally enforceable JV at the time of tendering, the Tender Security or the Tender-Securing Declaration shall be in the names of all future members as named in the letter of intent referred to in ITT 4.1 and ITT 11.2.
- 19.10** A tenderer shall not issue a tender security to guarantee itself.

20.0 *Format and Signing of Tender*

- 20.1** The Tenderer shall prepare one original of the documents comprising the Tender as described in ITT 11 and clearly mark it "ORIGINAL." Alternative Tenders, if permitted in accordance with ITT 13, shall be clearly marked "ALTERNATIVE." In addition, the Tenderer shall submit copies of the Tender, in the number specified in the TDS and clearly mark them "COPY." In the event of any discrepancy between the original and the copies, the original shall prevail.
- 20.2** Tenderers shall mark as "CONFIDENTIAL" all information in their Tenders which is confidential to their business. This may include proprietary information, trade secrets, or commercial or financially sensitive information.
- 20.3** The original and all copies of the Tender shall be typed or written in indelible ink and shall be signed by a person duly authorized to sign on behalf of the Tenderer. This authorization shall consist of a written confirmation as specified in the TDS and shall be attached to the Tender. The name and position held by each person signing the authorization must be typed or printed below the signature. All pages of the Tender where entries or amendments have been made shall be signed or initialed by the person signing the Tender.
- 20.4** In case the Tenderer is a JV, the Tender shall be signed by an authorized representative of the JV on behalf of the JV, and so as to be legally binding on all the members as evidenced by a power of attorney signed by their legally authorized representatives.
- 20.5** Any inter-lineation, erasures, or overwriting shall be valid only if they are signed or initialed by the person signing the Tender.

D. SUBMISSION AND OPENING OF TENDERS

21.0 *Sealing and Marking of Tenders*

- 21.1** The Tenderer shall deliver the Tender in a single sealed envelope, or in a single sealed package, or in a single sealed container bearing the name and Reference number of the Tender, addressed to the Procuring Entity and a warning not to open before the time and date for Tender opening date. Within the single envelope, package or container, the Tenderer shall place the following separate, sealed envelopes:
- a) in an envelope or package or container marked "ORIGINAL", all documents comprising the Tender, as described in ITT 11; and
 - b) in a nvelope or package or container marked "COPIES", all required copies of the Tender; and
 - c) if alternative Tenders are permitted in accordance with ITT 13, and if relevant:
 - i) in an envelope or package or container marked "ORIGINAL –ALTERNATIVE TENDER", the alternative Tender; and
 - ii) in the envelope or package or container marked "COPIES- ALTERNATIVE TENDER", all required copies of the alternative Tender.

The inner envelopes or packages or containers shall:

- a) bear the name and address of the Procuring Entity,
 - b) bear the name and address of the Tenderer; and
 - c) bear the name and Reference number of the Tender.
- 21.2** If an envelope or package or container is not sealed and marked as required, the *Procuring Entity* will assume no responsibility for the misplacement or premature opening of the Tender. Tenders misplaced or opened prematurely will not be accepted.

22.0 Deadline for Submission of Tenders

22.1 Tenders must be received by the Procuring Entity at the address specified in the **TDS** and no later than the date and time also specified in the **TDS**. When so specified in the **TDS**, tenderers shall have the option of submitting their Tenders electronically. Tenderers submitting Tenders electronically shall follow the electronic Tender submission procedures specified in the **TDS**.

22.2 The Procuring Entity may, at its discretion, extend the deadline for the submission of Tenders by amending the Tender Documents in accordance with ITT 8, in which case all rights and obligations of the Procuring Entity and Tenderers previously subject to the deadline shall thereafter be subject to the deadline as extended.

23.0 Late Tenders

The Procuring Entity shall not consider any Tender that arrives after the deadline for submission of tenders, in accordance with ITT 22. Any Tender received by the Procuring Entity after the deadline for submission of Tenders shall be declared late, rejected, and returned unopened to the Tenderer.

24.0 Withdrawal, Substitution, and Modification of Tenders

24.1 A Tenderer may withdraw, substitute, or modify its Tender after it has been submitted by sending a written notice, duly signed by an authorized representative, and shall include a copy of the authorization in accordance with ITT 20.3, (except that withdrawal notices do not require copies). The corresponding substitution or modification of the Tender must accompany the respective written notice. All notices must be:

- a) prepared and submitted in accordance with ITT 20 and ITT 21 (except that withdrawal notices do not require copies), and in addition, the respective envelopes shall be clearly marked "WITHDRAWAL," "SUBSTITUTION," "MODIFICATION;" and
- b) received by the Procuring Entity prior to the deadline prescribed for submission of Tenders, in accordance with ITT 22.

24.2 Tenders requested to be withdrawn in accordance with ITT 24.1 shall be returned unopened to the Tenderers.

24.3 No Tender may be withdrawn, substituted, or modified in the interval between the deadline for

submission of Tenders and the expiration of the period of Tender validity specified by the Tenderer on the Form of Tender or any extension thereof.

25. *Tender Opening*

- 251 Except in the cases specified in ITT 23 and ITT 24.2, the Procuring Entity shall publicly open and read out all Tenders received by the deadline, at the date, time and place specified in the TDS, in the presence of Tenderers' designated representatives who chooses to attend. Any specific electronic Tender opening procedures required if electronic Tendering is permitted in accordance with ITT 22.1, shall be as specified in the TDS.
- 252 First, envelopes marked "WITHDRAWAL" shall be opened and read out and the envelopes with the corresponding Tender shall not be opened but returned to the Tenderer. No Tender withdrawal shall be permitted unless the corresponding withdrawal notice contains a valid authorization to request the withdrawal and is read out at Tender opening.
- 253 Next, envelopes marked "SUBSTITUTION" shall be opened and read out and exchanged with the corresponding Tender being substituted, and the substituted Tender shall not be opened, but returned to the Tenderer. No Tender substitution shall be permitted unless the corresponding substitution notice contains a valid authorization to request the substitution and is read out at Tender opening.
- 254 Next, envelopes marked "MODIFICATION" shall be opened and read out with the corresponding Tender. No Tender modification shall be permitted unless the corresponding modification notice contains a valid authorization to request the modification and is read out at Tender opening.
- 255 Next, all remaining envelopes shall be opened one at a time, reading out: the name of the Tenderer and whether there is a modification; the total Tender Price, per lot (contract) if applicable, including any discounts and alternative Tenders; the presence or absence of a Tender Security or Tender-Securing Declaration, if required; and any other details as the Procuring Entity may consider appropriate.
- 256 Only Tenders, alternative Tenders and discounts that are opened and read out at Tender opening shall be considered further for evaluation. The Form of Tender and pages of the Bill of Quantities (to be decided on by the tender opening committee) are to be initialed by the members of the tender opening committee attending the opening.
- 257 At the Tender Opening, the Procuring Entity shall neither discuss the merits of any Tender nor reject any Tender (except for late Tenders, in accordance with ITT 23.1).
- 258 The Procuring Entity shall prepare minutes of the Tender Opening that shall include, as a minimum: -
- a) the name of the Tenderer and whether there is a withdrawal, substitution, or modification;
 - b) the Tender Price, per lot (contract) if applicable, including any discounts;
 - c) any alternative Tenders;
 - d) the presence or absence of a Tender Security, if new as required;
 - e) number of pages of each tender document submitted.
- 259 The Tenderers' representatives who are present shall be requested to sign the minutes. The omission of a Tenderer's signature on the minutes shall not invalidate the contents and effect of the minutes. A copy of the tender opening register shall be distributed to all Tenderers.

E. EVALUATION AND COMPARISON OF TENDERS

26. **Confidentiality**

- 261 Information relating to the evaluation of Tenders and recommendation of contract award shall not be disclosed to Tenderers or any other persons not officially concerned with the Tender process until information on Intention to Award the Contract is transmitted to all Tenderers in accordance with ITT 43.

262 Any effort by a Tenderer to influence the Procuring Entity in the evaluation of the Tenders or Contract award decisions may result in the rejection of its tender.

263 Notwithstanding ITT 26.2, from the time of tender opening to the time of contract award, if a tenderer wishes to contact the Procuring Entity on any matter related to the tendering process, it shall do so in writing.

27.0 Clarification of Tenders

27.1 To assist in the examination, evaluation, and comparison of the tenders, and qualification of the tenderers, the Procuring Entity may, at its discretion, ask any tenderer for a clarification of its tender, given a reasonable time for a response. Any clarification submitted by a tenderer that is not in response to a request by the Procuring Entity shall not be considered. The Procuring Entity's request for clarification and the response shall be in writing. No change, including any voluntary increase or decrease, in the prices or substance of the tender shall be sought, offered, or permitted, except to confirm the correction of arithmetic errors discovered by the Procuring Entity in the evaluation of the tenders, in accordance with ITT 31.

27.2 If a tenderer does not provide clarifications of its tender by the date and time set in the Procuring Entity's request for clarification, its Tender may be rejected.

28.0 Deviations, Reservations, and Omissions

28.1 During the evaluation of tenders, the following definitions apply: -

- a) *"Deviation"* is a departure from the requirements specified in the tender document;
- b) *"Reservation"* is the setting of limiting conditions or withholding from complete acceptance of the requirements specified in the tender document; and
- c) *"Omission"* is the failure to submit part or all of the information or documentation required in the Tender document.

29.0 Determination of Responsiveness

29.1 The Procuring Entity's determination of a Tender's responsiveness is to be based on the contents of the tender itself, as defined in ITT 11.

29.2 A substantially responsive Tender is one that meets the requirements of the Tender document without material deviation, reservation, or omission. A material deviation, reservation, or omission is one that, if accepted, would:

- a) affect in any substantial way the scope, quality, or performance of the Works specified in the Contract;
- b) limit in any substantial way, inconsistent with the tender document, the Procuring Entity's rights or the tenderer's obligations under the proposed contract;
- c) if rectified, would unfairly affect the competitive position of other tenderers presenting substantially responsive tenders.

29.3 The Procuring Entity shall examine the technical aspects of the tender submitted in accordance with ITT 16, to confirm that all requirements of Section VII, Works' Requirements have been met without any material deviation, reservation or omission.

29.4 If a tender is not substantially responsive to the requirements of the tender document, it shall be rejected by the Procuring Entity and may not subsequently be made responsive by correction of the material deviation, reservation, or omission.

30.0 Non-material Non-conformities

30.1 Provided that a tender is substantially responsive, the Procuring Entity may waive any non-conformities in the tender.

30.2 Provided that a Tender is substantially responsive, the Procuring Entity may request that the tenderer submit the necessary information or documentation, within a reasonable period of

time, to rectify non-material non-conformities in the tender related to documentation requirements. Requesting information or documentation on such non-conformities shall not be related to any aspect of the price of the tender. Failure of the tenderer to comply with the request may result in the rejection of its tender.

- 30.3** Provided that a tender is substantially responsive, the Procuring Entity shall rectify quantifiable non-material non-conformities related to the Tender Price. To this effect, the Tender Price shall be adjusted, for comparison purposes only, to reflect the price of a missing or non-conforming item or component in the manner specified in the **TDS**.

31.0 *Arithmetical Errors*

- 31.1** The tender sum as submitted and read out during the tender opening shall be absolute and final and shall not be the subject of correction, adjustment or amendment in any way by any person or entity.

- 31.2** Provided that the Tender is substantially responsive, the Procuring Entity shall handle errors on the following basis: -

- a) Any error detected if considered a major deviation that affects the substance of the tender, shall lead to disqualification of the tender as non-responsive.
- b) Any errors in the submitted tender arising from a miscalculation of unit price, quantity, subtotal and total bid prices shall be considered as a major deviation that affects the substance of the tender and shall lead to disqualification of the tender as non-responsive. and
- c) if there is a discrepancy between words and figures, the amount in words shall prevail

- 31.3** Tenderers shall be notified of any error detected in their bid during the notification of award.

32.0 *Conversion to Single Currency*

For evaluation and comparison purposes, the currency(ies) of the Tender shall be converted in to a single currency as specified in the **TDS**.

33.0 *Margin of Preference and Reservations*

- 33.1** A margin of preference may be allowed only when the contract is open to international competitive tendering where foreign contractors are expected to participate in the tendering process and where the contract exceeds the value/threshold specified in the Regulations.

- 33.2** A margin of preference shall not be allowed unless it is specified so in the **TDS**.

- 33.3** Contracts procured on basis of international competitive tendering shall not be subject to reservations exclusive to specific groups as provided in ITT 33.4.

- 33.4** Where it is intended to reserve a contract to a specific group of businesses (these groups are Small and Medium Enterprises, Women Enterprises, Youth Enterprises and Enterprises of persons living with disability, as the case may be), and who are appropriately registered as such by the authority to be specified in the **TDS**, a procuring entity shall ensure that the invitation to tender specifically indicates that only businesses or firms belonging to the specified group are eligible to tender. No tender shall be reserved to more than one group. If not so stated in the Invitation to Tender and in the Tender documents, the invitation to tender will be open to all interested tenderers.

34.0 *Nominated Subcontractors*

- 34.1** Unless otherwise stated in the **TDS**, the Procuring Entity does not intend to execute any specific elements of the Works by subcontractors selected/nominated by the Procuring Entity. In case the Procuring Entity nominates a subcontractor, the subcontract agreement shall be signed by the Subcontractor and the Procuring Entity. The main contract shall specify the working arrangements between the main contractor and the nominated subcontractor.

- 34.2** Tenderers may propose sub-contracting up to the percentage of total value of contracts or the

volume of works as specified in the **TDS**. Subcontractors proposed by the Tenderer shall be fully qualified for their parts of the Works.

34.3 Domestic subcontractor's qualifications shall not be used by the Tenderer to qualify for the Works unless their specialized parts of the Works were previously designated so by the Procuring Entity in the **TDS** a scan be met by subcontractors referred to hereafter as 'Specialized Subcontractors', in which case, the qualifications of the Specialized Subcontractors proposed by the Tenderer may be added to the qualifications of the Tenderer.

35. Evaluation of Tenders

35.1 The Procuring Entity shall use the criteria and methodologies listed in this ITT and Section III, Evaluation and Qualification Criteria No other evaluation criteria or methodologies shall be permitted. By applying the criteria and methodologies the Procuring Entity shall determine the Lowest Evaluated Tender in accordance with ITT 40.

35.2 To evaluate a Tender, the Procuring Entity shall consider the following:

- a) price adjustment in accordance with ITT 31.1 (iii); excluding provisional sums and contingencies, if any, but including Daywork items, where priced competitively;
- b) price adjustment due to discounts offered in accordance with ITT 14.4;
- c) converting the amount resulting from applying (a) and (b) above, if relevant, to a single currency in accordance with ITT 32;
- d) price adjustment due to quantifiable non material non-conformities in accordance with ITT 30.3; and
- e) any additional evaluation factors specified in the **TDS** and Section III, Evaluation and Qualification Criteria.

35.3 The estimated effect of the price adjustment provisions of the Conditions of Contract, applied over the period of execution of the Contract, shall not be considered in Tender evaluation.

35.4 Where the tender involves multiple lots or contracts, the tenderer will be allowed to tender for one or more lots (contracts). Each lot or contract will be evaluated in accordance with ITT 35.2. The methodology to determine the lowest evaluated tenderer or tenderers base done lot (contract) or based on a combination of lots (contracts), will be specified in Section III, Evaluation and Qualification Criteria. In the case of multiple lots or contracts, tenderer will be required to prepare the Eligibility and Qualification Criteria Form for each Lot.

36.0 Comparison of tenders

The Procuring Entity shall compare the evaluated costs of all substantially responsive Tenders established in accordance with ITT 35.2 to determine the Tender that has the lowest evaluated cost.

37.0 Abnormally low tenders and abnormally high tenders

Abnormally Low Tenders

37.1 An Abnormally Low Tender is one where the Tender price, in combination with other elements of the Tender, appears so low that it raises material concerns as to the capability of the Tenderer in regards to the Tenderer's ability to perform the Contract for the offered Tender Price or that genuine competition between Tenderers is compromised.

37.2 In the event of identification of a potentially Abnormally Low Tender, the Procuring Entity shall seek written clarifications from the Tenderer, including detailed price analyses of its Tender price in relation to the subject matter of the contract, scope, proposed methodology, schedule, allocation of risks and responsibilities and any other requirements of the Tender document.

37.3 After evaluation of the price analyses, in the event that the Procuring Entity determines that the

Tenderer has failed to demonstrate its capability to perform the Contract for the offered Tender Price, the Procuring Entity shall reject the Tender.

Abnormally high tenders

37.4 An abnormally high tender price is one where the tender price, in combination with other constituent elements of the Tender, appears unreasonably too high to the extent that the Procuring Entity is concerned that it (the Procuring Entity) may not be getting value for money or it may be paying too high a price for the contract compared with market prices or that genuine competition between Tenderers is compromised.

37.5 In case of an abnormally high price, the Procuring Entity shall make a survey of the market prices, check if the estimated cost of the contract is correct and review the Tender Documents to check if the specifications, scope of work and conditions of contract are contributory to the abnormally high tenders. The Procuring Entity may also seek written clarification from the tenderer on the reason for the high tender price. The Procuring Entity shall proceed as follows:

- i) If the tender price is abnormally high based on wrong estimated cost of the contract, the Procuring Entity may accept or not accept the tender depending on the Procuring Entity's budget considerations.
- ii) If specifications, scope of work and/or conditions of contract are contributory to the abnormally high tender prices, the Procuring Entity shall reject all tenders and may retender for the contract based on revised estimates, specifications, scope of work and conditions of contract, as the case may be.

37.6 If the Procuring Entity determines that the Tender Price is abnormally too high because genuine competition between tenderers is compromised (*often due to collusion, corruption or other manipulations*), the Procuring Entity shall reject all Tenders and shall institute or cause competent Government Agencies to institute an investigation on the cause of the compromise, before retendering.

38.0 Unbalanced and/ or front-loaded tenders

38.1 If in the Procuring Entity's opinion, the Tender that is evaluated as the lowest evaluated price is seriously unbalanced and/or frontloaded, the Procuring Entity may require the Tenderer to provide written clarifications. Clarifications may include detailed price analyses to demonstrate the consistency of the tender prices with the scope of works, proposed methodology, schedule and any other requirements of the Tender document.

38.2 After the evaluation of the information and detailed price analyses presented by the Tenderer, the Procuring Entity may as appropriate:

- a) accept the Tender;
- b) require that the total amount of the Performance Security be increased at the expense of the Tenderer to a level not exceeding a 30% of the Contract Price;
- c) agree on a payment mode that eliminates the inherent risk of the Procuring Entity paying too much for undelivered works;
- d) reject the Tender,

39.0 Qualifications of the tenderer

39.1 The Procuring Entity shall determine to its satisfaction whether the eligible Tenderer that is selected as having submitted the lowest evaluated cost and substantially responsive Tender, meets the qualifying criteria specified in Section III, Evaluation and Qualification Criteria.

39.2 The determination shall be based upon an examination of the documentary evidence of the Tenderer's qualifications submitted by the Tenderer, pursuant to ITT 17. The determination shall not take into consideration the qualifications of other firms such as the Tenderer's subsidiaries, parent entities, affiliates, subcontractors (other than Specialized Sub-contractors if permitted in the Tender document), or any other firm(s) different from the Tenderer.

39.3 An affirmative determination shall be a prerequisite for award of the Contract to the Tenderer.

A negative determination shall result in disqualification of the Tender, in which event the Procuring Entity shall proceed to the Tenderer who offers a substantially responsive Tender with the next lowest evaluated price to make a similar determination of that Tenderer's qualifications to perform satisfactorily.

40.0 *Lowest evaluated tender*

Having compared the evaluated prices of Tenders, the Procuring Entity shall determine the Lowest Evaluated Tender. The Lowest Evaluated Tender is the Tender of the Tenderer that meets the Qualification Criteria and whose Tender has been determined to be:

- a) Most responsive to the Tender document; and
- b) the lowest evaluated price.

41.0 *Procuring entity's right to accept any tender, and to reject any or all tenders.*

The Procuring Entity reserves the right to accept or reject any Tender and to annul the Tender process and reject all Tenders at any time prior to Contract Award, without there by incurring any liability to Tenderers. In case of annulment, all Tenders submitted and specifically, Tender securities, shall be promptly returned to the Tenderers.

F. AWARD OF CONTRACT

42.0 *Award criteria*

The Procuring Entity shall award the Contract to the successful tenderer whose tender has been determined to be the Lowest Evaluated Tender.

43.0 *Notice of Intention to Enter into a Contract/Notification of Award*

Upon award of the contract and Prior to the expiry of the Tender Validity Period the Procuring Entity shall issue a Notification of Intention to Enter into a Contract/Notification of award to all tenderers which shall contain, at a minimum, the following information:

- a) the name and address of the Tenderer submitting the successful tender;
- b) the Contract price of the successful tender;
- c) a statement of the reason(s) the tender of the unsuccessful tenderer to whom the letter is addressed was unsuccessful, unless the price information in (c) above already reveals the reason;
- d) the expiry date of the Standstill Period; and
- e) instruction on how to request a debriefing and/ or submit a complaint during the stand still period;

44.0 *Stand still Period*

44.1 The Contract shall not be signed earlier than the expiry of a Standstill Period of 14 days to allow any dissatisfied tender to launch a complaint. Where only one Tender is submitted, the Standstill Period shall not apply.

44.2 Where a Standstill Period applies, it shall commence when the Procuring Entity has transmitted to each Tenderer the Notification of Intention to Enter into a Contract with the successful Tenderer.

45.0 *Debriefing by The Procuring Entity*

45.1 On receipt of the Procuring Entity's Notification of Intention to Enter into a Contract referred to in ITT 43, an unsuccessful tenderer may make a written request to the Procuring Entity for a debriefing on specific issues or concerns regarding their tender. The Procuring Entity shall provide the debriefing within five days of receipt of the request.

45.2 Debriefings of unsuccessful Tenderers may be done in writing or verbally. The Tenderer shall bear its own costs of attending such a debriefing meeting.

46.0 *Letter of Award*

Prior to the expiry of the Tender Validity Period and upon expiry of the Standstill Period specified in ITT 42.1, upon addressing a complaint that has been filed with in the Standstill Period, the Procuring Entity shall transmit the Letter of Award to the successful Tenderer. The letter of award shall request the successful tenderer to furnish the Performance Security within 21 days of the date of the letter.

47.0 *Signing of Contract*

47.1 Upon the expiry of the fourteen days of the Notification of Intention to enter in to contract and upon the parties meeting their respective statutory requirements, the Procuring Entity shall send the successful Tenderer the Contract Agreement.

47.2 Within fourteen (14) days of receipt of the Contract Agreement, the successful Tenderer shall sign, date, and return to the Procuring Entity.

47.3 The written contract shall be entered into within the period specified in the notification of award and before expiry of the tender validity period.

48.0 *Performance Security*

48.1 Within twenty-one (21) days of the receipt of the Letter of Award from the Procuring Entity, the successful Tenderer shall furnish the Performance Security and, any other documents required in the **TDS**, in accordance with the General Conditions of Contract, subject to ITT 38.2 (b), using the Performance Security and other Forms included in Section X, Contract Forms, or another form acceptable to the Procuring Entity. A foreign institution providing a bank guarantee shall have a correspondent financial institution located in Kenya, unless the Procuring Entity has agreed in writing that a correspondent bank is not required.

48.2 Failure of the successful Tenderer to submit the above-mentioned Performance Security and other documents required in the **TDS** or sign the Contract shall constitute sufficient grounds for the annulment of the award and forfeiture of the Tender Security. In that event the Procuring Entity may award the Contract to the Tenderer offering the next Best Evaluated Tender.

48.3 Performance security shall not be required for contracts estimated to cost less than the amount specified in the Regulations.

49.0 *Publication of Procurement Contract*

Within fourteen days after signing the contract, the Procuring Entity shall publish the awarded contract at its notice boards and websites; and on the Website of the Authority. At the minimum, the notice shall contain the following information:

- a) name and address of the Procuring Entity;
- b) name and reference number of the contract being awarded, a summary of its scope and the selection method used;
- c) the name of the successful Tenderer, the final total contract price, the contract duration;
- d) dates of signature, commencement and completion of contract;
- e) names of all Tenderers that submitted Tenders, and their Tender prices as readout at Tender opening.

50.0 *Procurement related Complaints and Administrative Review*

50.1 The procedures for making Procurement-related Complaints are as specified in the **TDS**.

50.2 A request for administrative review shall be made in the form provided under contract forms.

SECTION II - TENDER DATA SHEET

The following specific data for the Facilities to be procured shall complement, supplement, or amend the provisions in the Instructions to Tenderers (ITT). Whenever there is a conflict, the provisions here in shall prevail over those in ITT.

Reference to ITC Clause	PARTICULARS OF APPENDIX TO INSTRUCTIONS TO TENDERS
A. General	
ITT 1.1	<p>The reference number of the Invitation to Tender (ITT) is: RFX 1000001578</p> <p>The Procuring Entity is: RURAL ELECTRIFICATION AND RENEWABLE ENERGY CORPORATION (RREC)</p> <p>The name of the ITT is: Manda Island 11kv Double Circuit Power Line Ocean Channel Crossing & Associated Works (Retender)</p>
ITT 2.1	<p>The name of the Project is: Manda Island 11kv Double Circuit Power Line Ocean Channel Crossing & Associated Works (Retender)</p> <p>Electronic –Procurement System shall be used</p> <p>Name of the e-system: SAP -SRM</p> <p>The Procuring Entity shall use the following electronic-procurement system to manage this Tendering process: SAP -SRM</p> <p>The electronic-procurement system shall be used to manage the following aspects of the Tendering process:</p> <ol style="list-style-type: none"> i. Issuing tendering document, ii. Submissions of Tenders, iii. Opening of Tender iv. Contract Preparation
ITT 4.0	Eligible Tenderers - Tender is open to all Citizen Contractors.
ITT 4.1	Maximum number of members in the Joint Venture (JV) shall be: <i>Three (3) Main Contractor should have experience in Civil Engineering.</i>
B. Content of Tender Document	
ITT 8.1	<p>(a) Address where to send enquiries is tenders@rrec.co.ke to reach the Procuring Entity not later than fourteen (14) day to the close of the tender document latest 12:00 noon.</p> <p>(b) The Procuring Entity shall publish its response at the website or via email on same day of the clarification.</p>
	A Mandatory Pre-Bid and pre site visit meeting <i>shall</i> take place at the following date, time and place:

a) Pre site visit

The pre-arranged pre-tender **Mandatory** visit of the site of the works **will be held** as indicated below;

DATE	TIME	STARTING POINT
08 th - 12 th June 2026	10.00Am	Manda Island

N/B :

- Pre-bid Site Visit is mandatory to all bidders and bidder’s representative shall include at least one technical staff who shall sign the site visit form.
- Bidders who had previously visited the site are exempted but shall be required to attach the previous site visit form with their bid.

b) Pre-bid meeting

Date: **16th July, 2026**

Time: **9.30hrs East Africa Time**

Place: **The Auditorium, KAWI Complex**

ITT 8.2

Any questions in writing, shall reach the Procuring Entity not later than fourteen (14) day to the close of the tender document.

ITT 8.4

Minutes of the pre-Tender meeting and the pre-arranged pretender visit of the site of the works will be published at the website www.rerec.co.ke

ITT 9.1

The Procuring Entity shall publish its response at the website www.rerec.co.ke

C. Preparation of Tenders

ITT 13.1 (j)

The Tenderer shall submit the following additional documents in its Tender;
The Bidder shall submit the following additional documents in its Bid for the following major items as listed below:

1. The tenderer **SHALL** provide latest Audited financial reports for the last 2 years. Signed by a certified public accountant and company directors. Submit Valid ICPAK Practicing License of the certified public accountant.
2. The tenderer **SHALL** submit details of the technology he is proposing to use together with test certificates (concrete poles, pylon towers, conductor, OPGW, insulators & underground cable), tower testing station technical data and datasheets of cable support, tower bolts and nuts, anchor lag/bolts.
3. Submission of manufacturers contact details including a valid official email address (gmail or yahoo email address will not be accepted) and secure website for international companies.
4. Submission of details of experience and past performance on works of a similar nature within the past five years and details of current work on hand

and other contractual commitments. The works should be for transmission power line construction and associated works. The tenderer to attach at least 3 completion certificates from the owner of the works undertaken. Tenderer should provide names with full contact as well as physical addresses of previous Engineering Procurement and Construction (EPC) contracts of similar works and commissioning certificate at least 2 years past experience in relevant works

5. Confirmation of business Premise, workshops and service center with relevant tools and equipment whether owned or leased with evidence of valid lease agreements and OSHA registration of workplace certificate.
6. Submission of valid NCA 4 and above – Electrical services or Mechanical services and NCA 4 and above for Building, Roads or Civil Works. Submission of valid electrical services EPRA license Class A1.
7. Submission of Manufacturer's ISO 14001:2015 certificate
8. Company Incorporation Certificate, KRA Pin certificate Income & VAT, Valid Tax Compliance Certificate, Valid Trade License/Business Permit (to be verified via scan codes), Certificate of Confirmation of Directors and Shareholding (C.R. 12) Not more than three months old for the bidder and all JV partners and Power of attorney commissioned by commissioner of Oath/Notary Public: - established in the name of the signatory of the bid and his/her sample signature appended on it. The valid practicing certificate of the advocate or commissioner of oaths must accompany all certified or commissioned documents
9. In case the Bidder is a JV, the Bid shall be signed by an authorized representative of the JV on behalf of the JV, and so as to be legally binding on all the members as evidenced by a power of attorney signed by their legally authorized representatives.
10. Submission of Manufacturer's ISO9001:2015 certificate for quality management OR KEBS certification for the key equipment, should be valid.
11. Submission of evidence of an established up to date safety program, policies and work practices. Bidder to provide a written occupational health and safety policy.
12. Confirmation that the contractor has no REREC pending works beyond the project implementation period provided in the contract. This is a mandatory

	<p>fulfillment and a bidder who fails on this parameter shall be deemed non responsive</p> <p>13. Confirmation of Submission and verification that the Tender Form duly completed, stamped, signed by the bidder in the format provided in the tender and all attachments thereto Commissioned by Commissioner of Oaths or a Magistrate of the Kenyan Judiciary.</p> <p>14. Duly filled, signed and stamped Bill of quantities and price schedules.</p> <p>15. Site visit form signed and stamped by authorized REREC staff.</p> <p>16. Where Applicable, Submission of Registration Certificate as a contractor with NCA and (ERC) EPRA in category and Class for sub-contractors.</p> <p>17. Record of unsatisfactory or default in performance obligations in any contract shall be considered. This shall include any tenderer with unresolved case(s) in its performance obligations for more than twelve (12) months in any previous contracts.</p> <p>NOTE: Provide any other requirements as indicated in the technical evaluation criteria and Bill of Quantities</p>
ITT 15.1	Alternative Tenders <i>shall not be</i> considered.
ITT 15.2	<p>Alternatives to the Time Schedule <i>shall not be</i> permitted.</p> <p>If alternatives to the Time Schedule are permitted, the evaluation method will be as specified in Section III, Evaluation and Qualification Criteria.</p>
ITT 15.4	<p>Alternative technical solutions shall be permitted for the following parts of the Plant and Installation Services: N/A</p> <p>If alternative technical solutions are permitted, the evaluation method will be as specified in Section III, Evaluation and Qualification Criteria.</p>
ITT 19.1	Tenderers shall quote for the following components or services on a single responsibility basis: N/A
ITT 19.5 (a) and (d)	<p>Place of destination: Delivered Duty Paid to project site</p> <p>Final destination (Project Site): Respective project</p>
ITT 19.6	The Incoterms edition is: 2020
ITT 19.7	The prices quoted by the Tenderer <i>shall not</i> be subject to adjustment during the performance of the Contract.
ITT 20.1	The currencies of the bid shall be any easily convertible currencies but no more than two foreign currencies in addition to Local Currency.
ITT 21.1	The Tender validity period shall be One Hundred and fifty (150) days s from the date of tender opening.

ITT 21.3 (a)	The Tender price shall be adjusted by the following factor(s): Not Applicable (N/A)
ITT 22.1	Bidder shall furnish a bid security in the form of a Bank Guarantee issued by Banks Licensed by the Central Bank of Kenya of Kshs 5,800,000
ITT 23.1	All tenders shall be submitted through the REREC SAP online tendering portal in PDF format.
ITT 23.3	<p>The written confirmation of authorization to sign on behalf of the Tenderer shall consist of: <i>Power of attorney commissioned by a commissioner of oath/Notary Public: - established in the name of the signatory of the bid and his/her sample signature appended on it. The valid practicing certificate of the advocate or commissioner of oaths must accompany all certified or commissioned documents.</i></p> <p><i>In case the Bidder is a JV, the Bid shall be signed by an authorized representative of the JV on behalf of the JV, and so as to be legally binding on all the members as evidenced by a power of attorney signed by their legally authorized representatives</i></p>
D. Submission and Opening of Tenders	
ITT 25.1	<p>For <u>Tender submission purposes</u> only, the Procuring Entity's address is</p> <p>A) For <u>Tender submission purposes</u> only, the Procuring Entity's address is:</p> <p>Chief Executive Officer</p> <p>Rural Electrification Authority and Renewable Energy Corporation Kawi Complex, South C, P.O. BOX 34585 -00100 <u>NAIROBI, KENYA</u></p> <p>Telephone: +254 709 193000</p> <p>Email: procurement@rerec.co.ke and tenders@rerec.co.ke</p> <p>Date and time for submission of Tenders: 03rd July , 2026 at 10.00am.</p> <p>Tenderers SHALL SUBMIT tenders electronically</p> <p>The electronic Tendering submission procedures shall be:</p> <p>The Bidder shall process and submit its Bid via the Corporation's e-Procurement system as follows:</p> <p>a) For tenderers who have have not registered their companies with the Corporation and have not created employee user; complete company registration form available on website; https://suppliers.rea.co.ke:44200/supportal(bD1lbiZjPTUwMCZkPW1pbg==)/bspwdapplication.do#VIEW_ANCHOR-ROS_TOP</p> <p>For tenderers who have completed registration, Login to REREC portal via url https://suppliers.rea.co.ke:44300/irj/portal</p> <p>N/B: For the purpose of bidding, ensure the following;</p>

	<ul style="list-style-type: none"> • The company has two user accounts; Admin and Employee account • Employee account is not assigned Employee administrator and Supplier master data role • Employee and Admin account do not share email or telephone number details • Employee user name is between 4-12 characters • Employee account is used to submit this tender <p>b) Chose RFX and Actions link in the navigation pane</p> <p>c) Click on RFX no. to open it</p> <p>d) Click Register, then participate</p> <p>e) Click Create a response; a unique number for your response will be generated</p> <p>f) Navigate notes and attachment tab and click on collaboration link at the bottom of your screen(the link will be in the format “RFX Response No: Company Name”. If under your notes and attachment no link is formed in the collaboration room, you are advised to delete the response and create a new one until the link is formed, in this link all the documents of the tender shall be uploaded.</p> <p>NB: All supplier bid documents/Responses shall be uploaded to the Collaboration ROOM (Cfolder) in the link with “RFX Response Number: Company Name”. Bidders shall not attach their documents at any other Tab of the Portal. Attachments placed on “Notes and Attachment Tab” shall not be evaluated and the bid will be declared a non-responsive.</p> <p>g) Log in to the collaboration link and follow the steps on the quick bid guide; https://www.rerec.co.ke/assets/images/important_document/Supplier-Bidding-Quick-reference-guide.pdf to upload the required documents</p> <p>h) Click on items tab and enter the bid prices as summarized on your price schedule. Price should include all applicable taxes. <i>N/B; This is the price that will be read during tender opening. No value shall be entered under the RFX information “Target Value for RFX”.</i></p> <p>i) Check for errors by clicking the check button</p> <p>j) Click on save to review your response and submit to send your response to REREC</p>
<p>ITT 28.1</p>	<p>The Tender opening shall take place at:</p> <p>(1) Name of Procuring Entity: RURAL ELECTRIFICATION AND RENEWABLE ENERGY CORPORATION , SOUTH C, OFF RED CROSS ROAD, KAWI COMPLEX, BLOCK C- GROUND FLOOR</p> <p>Date and time for submission of Tenders: 03rd July, 2026 at 10AM</p> <p>Original Bid Security shall be delivered to the tender Box (Kawi Complex Block C Ground Floor Off Popo Road)</p> <p>The electronic Tender opening procedures shall be:</p> <p>i.) Tenders shall be opened electronically</p>

	<p>ii.) Prices from items tab shall be read as opening price schedule</p> <p>iii.) Opening minutes shall be sent to all bidder via email and the same will be uploaded to the Corporation's Website.</p> <p><i>Only dully submitted Bids that are opened and prices read out at Bid opening shall be considered further in the evaluation.</i></p>
E. Evaluation, and Comparison of Tenders	
ITT 29.3	The Procuring Entity shall examine the technical aspects of the tender submitted in accordance with ITT 16, to confirm that all requirements of Section VII, Works' Requirements have been met without any material deviation, reservation or omission.
ITT 33.3	The adjustment shall be based on the [<i>insert "average" or "highest"</i>] price of the item or component as quoted in other substantially responsive Tenders. If the price of the item or component cannot be derived from the price of other substantially responsive Tenders, the Procuring Entity shall use its best estimate. N/A
ITT 34.2	Subject to section 79(2)(b) of the Act, any errors in the submitted tender arising from a miscalculation of unit price, quantity, subtotal and total bid price shall be considered as a major deviation that affects the substance of the tender and shall lead to disqualification of the tender as non-responsive as per Regulation 74(2) of the PPADR
ITT 35.1	<p>The currency that shall be used for Tender evaluation and comparison purposes to convert (at the selling exchange rate) all Tender prices expressed in various currencies into a single currency is: Kenya Shillings</p> <p>The source of exchange rate shall be: <i>Central Bank in Kenya</i></p> <p>The date for the exchange rate shall be: <i>Tender Closing date</i></p>
ITT 36.2	A margin of preference <u>shall be</u> allowed. N/A
ITT 37.4 (e)	<p>The adjustments shall be determined using the following criteria, from amongst those set out in Section III, Evaluation and Qualification Criteria: N/A</p> <p>(a) Deviation in Time for Completion: N/A</p> <p>(b) Life cycle costs: the projected operating and maintenance costs during the life of the goods or equipment; N/A</p> <p>(c) Functional Guarantees of the Facilities :N/A</p> <p>(d) Work, services, facilities, etc., to be provided by the Procuring Entity; N/A</p> <p>(e) <i>Any other specific criteria here:None</i></p>
ITT 45 Standstill Period	The Standstill Period is FOURTEEN (14) Business Days after the date REREC has transmitted to all Tenderers that submitted a Tender, the Notification of its Intention to Award the Contract to the successful Tenderer.
ITT 51	N/A
ITT 52.1	<p>The procedures for making a Procurement-related Complaint are detailed in the "Notice of Intention to Award the Contract" herein and are also available from the PPRA website info@ppra.go.ke or complaints@ppra.go.ke.</p> <p>Chief Executive Officer</p>

Rural Electrification and Renewable Energy Corporation (REREC) Kawi Complex,
South C,

P.O. BOX 34585 -00100

NAIROBI, KENYA

Telephone: + 254 709 193000

Email: info@rerec.co.ke

tenders@rerec.co.ke

In summary, a Procurement-related Complaint may challenge any of the following:

1. the terms of the Tendering Documents; and
2. the Procuring Entity's decision to award the contract.

9. EVALUATION AND CONTRACT AWARD CRITERIA

The Procuring Entity shall use the criteria and methodologies listed in this Section to evaluate tenders and arrive at the Lowest Evaluated Tender. The tender that (i) meets the qualification criteria, (ii) has been determined to be substantially responsive to the Tender Documents, and (iii) is determined to have the Lowest Evaluated Tender price shall be selected for award of contract.

9.1 PRELIMINARY EXAMINATION FOR DETERMINATION OF RESPONSIVENESS

The Procuring Entity will start by examining all tenders to ensure they meet in all respects the eligibility criteria and other requirements in the ITT, and that the tender is complete in all aspects in meeting the requirements of “Part 2 – Procuring Entity's Works Requirements”, including checking for tenders with unacceptable errors, abnormally low tenders, abnormally high tenders and tenders that are front loaded. Tenders that do not pass the Preliminary Examination will be considered irresponsible and will not be considered further.

9.1.1 PRELIMINARY EVALUATION

The following are the **MANDATORY** Requirements that **SHALL** constitute the evaluation criteria at the Preliminary Evaluation Stage:

1. Confirmation that the Bidder documents/Attachments have been submitted in the Collaboration folder of the SAP SRM System. Bidders shall not attach their documents at any other Tab of the Portal. Attachments placed elsewhere in the portal shall be declared non-responsive and the attachments shall not be evaluated.
2. Confirmation that the bidder's prices appear during tender opening. The entered prices in the items tab of SRM portal must be the same as the prices in the tender form/price schedules and the same prices are read out during opening (Award shall be based on read out price)
3. Confirmation of Submission of a valid tender security during opening in form of a Bank guarantee. The value of the Tender Security shall be as specified in TDS and valid for 180 days.
4. Submission of copies of Company or Firm's Registration Certificate, Company's E-PIN Certificate with both VAT & Income Tax obligations and Valid Tax compliance certificate
5. (CR12/CR13) form from Registrar of Companies, not more than Three (3) months old for all companies as is applicable and certified by a Commissioner of Oaths or a Magistrate of the Kenyan Judiciary.

6. Submission of a copy of valid Trade License/Business permit in the county of operation (to be verified via scan codes) with Evidence of physical registered office (attach utility bills/ lease agreement /rental payment receipt/ evidence of ownership of the premises) for all companies as is applicable
7. A written Power of Attorney, commissioned by commissioner of oaths, or a Magistrate of the Kenyan Judiciary stamped and signed by company directors including the specimen signature of the Authorized person and National ID for the Authorized person signing the document on behalf of the tenderer. In case the Bidder is a JV, the Bid shall be signed by an authorized representative of the JV on behalf of the JV, and so as to be legally binding on all the members as evidenced by a power of attorney signed by their legally authorized representatives.
8. Confirmation of Submission and verification that the Tender Form duly completed, stamped, signed by the bidder in the format provided in the tender and all attachments thereto Commissioned by Commissioner of Oaths or a Magistrate of the Kenyan Judiciary
9. Submission of a dully filled, signed and stamped price schedule form.
10. Submission of dully filled Qualification forms
 - i. Form EQU
 - ii. Form Personnel
 - iii. Tenderer Information Form
 - iv. Form Con -2
 - v. Form Fin 3.1, 3.2, 3.3, & 3.4
 - vi. Form Up 4.1, 4.2 (a) & 4.2 (b)
11. The tenderer SHALL provide latest Audited financial reports for the last 2 years. Signed by a certified public accountant and company directors. Submit Valid ICPAK Practicing License of the certified public accountant.
12. The tenderer SHALL submit details of the technology he is proposing to use together with catalogues and datasheets of all the equipment.
13. Submission of manufacturers contact details including a valid official email address (Gmail or yahoo email address will not be accepted) and secure website for international companies.
14. Submission of details of experience and past performance on works of a similar nature within the past five years and details of current work on hand and other contractual commitments. The works should be for transmission power line construction and associated works. The tenderer to attach at least 3 completion certificates from the owner of the works undertaken. Tenderer should have at least 2 years past experience in relevant works. The Tenderer shall submit at least three (3) names with full contact including telephone, email and physical addresses of previous clients (end users) of similar goods with their reference letters and /or completion certificates.

15. Confirmation of business Premise, workshops and service center with relevant tools and equipment whether owned or leased with evidence of valid lease agreements and OSHA registration of workplace certificate.
16. Submission of valid NCA 4 and above – Electrical services or Mechanical services and NCA 4 and above for Building, Roads or Civil Works. Submission of valid electrical services EPRA license Class A1.
17. Submission of Manufacturer’s ISO 14001:2015 certificate OR NEMA license for key equipment – solar cleaning equipment, should be valid.
18. Submission of Manufacturer’s ISO9001:2015 certificate for quality management OR KEBS certification for the key equipment, should be valid.
19. Submission of evidence of an established up to date safety program, policies and work practices. Bidder to provide a written occupational health and safety policy.
20. Confirmation that the contractor has no REREC pending works beyond the project implementation period provided in the contract. This is a mandatory fulfillment and a bidder who fails on this parameter shall be deemed non responsive. Record of unsatisfactory or default in performance obligations in any contract shall be considered. This shall include any tenderer with unresolved case(s) in its performance obligations for more than twelve (12) months in any previous contracts.
21. The Tenderer shall chronologically serialize all pages of the tender document submitted.

NB: Tenderers will proceed to the Technical evaluation only if they qualify in compliance Preliminary Evaluation above.

9.2 Technical Evaluation

Part 1

9.2.1 Technical document submission requirement

1	Confirmation of technical specification and information for ALL MAJOR ITEMS against tender requirements
2	For goods manufactured outside Kenya, applicable recent and valid QMS/EMS/SRM/OSHA Accreditation Certificate ISO 9001:2015 or ISO 14001:2015 or ISO 26000:2010 or ISO 45001:2018
3	For goods manufactured in Kenya - valid KEBS Mark of Quality Certificate or KEBS Standardization Mark Certificate.
4	Submission of Copies of relevant Type Test Certificates and their Reports or Acceptance Test Certificate and their Reports from the accredited testing laboratory, not more than 5 years old from the date of testing.
5	Submission of accreditation certificate for the testing laboratory to Testing Accreditation Certificate ISO/IEC 17025:2017 or ISO/IEC 17065:2012 or equivalent
6	Considering the Schedule of Guaranteed Technical Particulars (GTPs) and compliance to REREC requirements, and on the manufacturer’s letterhead for all major items.
7	Technical Drawings and Catalogues and/or Brochures. Technical drawings must contain title block in English language and on the manufacturer’s letterhead.

8	Submission of Manufacturer experience, list of previous customers and customer sales records
9	Submission of a dully filled Manufactures Authorization Form
10	Submission of Manufacturers Guarantees and Warranty
11	Submission of Manufacturers Capacity Declaration
12	Submission of Statement of compliance to specification (indicate deviations if any & support documents)
13	Submission of Works implementation schedule in Gantt chart
14	Submission of Works methodology/statement, Quality Management Plan and ESHS plan
15	Submission of Academic Qualification and CVs of key Expert for;

Staff	Minimum Academic/Professional Qualification	Total Work Experience (minimum)	Specific Experience in Similar Works (minimum)	No. of Personnel Required (minimum)	
1) Key Technical Staff					
1.	Project Manager (Civil or Structural or Electrical Engineer)	<ul style="list-style-type: none"> Degree in Engineering Project Management Diploma or Certificate or PMP Professional Engineer 	10 years	3 years	1
2.	Design/Construction Electrical Engineer	<ul style="list-style-type: none"> Degree in Electrical and Electronics or Telecommunications Engineering Professional Engineer 	7 years	3 years	1
3.	Design Structural and Civil Engineer	<ul style="list-style-type: none"> Degree in Civil and/or Structural Engineering Professional Engineer 	7 years	3 years	1
4.	Construction Civil Engineer	<ul style="list-style-type: none"> Degree in Civil and/or Structural Engineering Graduate Engineer 	7 years	3 years	1
5.	Geologist	<ul style="list-style-type: none"> Degree in Geology Relevant Professional Qualification 	7 years	3 years	1
6.	Geospatial Engineer	<ul style="list-style-type: none"> Degree in Geospatial Engineering Graduate Engineer Relevant Professional Qualification 	7 years	3 years	1

7.	Safety Officer	<ul style="list-style-type: none"> • Degree or Diploma or Certificate in Civil or Structural or Electrical Engineering • Diploma or Certificate in Safety • Relevant Professional Qualification 	7 years	3 years	1
II) Other Technical Staff					
1.	Environmental Expert	<ul style="list-style-type: none"> • Degree or Diploma in Environmental or equivalent • Relevant Professional Qualification 	7 years	3 years	1
2.	Technicians	• Diploma in Civil or Structural Engineering	5 years	3 years	2
		• Diploma in Electrical Engineering	5 years	3 years	2

Note: Key Personnel shall be all Kenyan Citizen, however, for specialized task the Contractor can bring in a specialist.

- Confirming that the audited financial Statements are for the last three (3) years. The latest audited financial statements must be those that are reported within twelve (12) calendar months of the date of the tender document. The statement must be stamped and signed. The auditors must be valid ICPAK registered practitioner

NB: Tenderers must clearly indicate the Auditor's ICPAK practicing License registration number in the audited financial statement report)

- **Requirement for detailed assessment of adequacy of technical Proposals, personnel and performance qualifications:-**
 - The detailed technical evaluation shall be carried out to ensure the tenderer meets particular technical requirements for the works and materials supplies as follows:
 - Schedule of mandatory Guaranteed Technical Particulars (GTP) shall be evaluated against tender specifications to confirm compliance of the materials to the technical specifications, and evaluation of any deviations and exceptions declared by the Tenderer.
 - Type Test Certificates and their Reports from the testing laboratory for full compliance with materials technical Specifications.
 - Detailed evaluation of the following documents as required in the tender document:
 - a) Tenderer's Work experience and performance qualification with supporting documents (reference letters)
 - b) Manufacturer's experience, and sales records with supporting document
 - c) Works implementation schedule to meet project time lines.
 - d) Works methodology/statement to meets the Work specifications
 - e) Qualification details of contractors key project implementation team
 - f) Proposed design drawings, manufacturer's catalogue and brochures
 - The assessment of the Technical Proposals submitted by a Bidder shall comprise;

- a) Bidder's technical capacity to mobilize key equipment and personnel to carry out the works,
- b) Design capacity
- c) Construction methodology
- d) Construction schedule
- e) Contractor Performance qualification
- f) Sufficiently detailed supply sources to meet works requirement
 - Key Personnel The Tenderer shall provide detailed CV (work experience) and Academic certificates of the proposed personnel per Lot in the format specified in forms PER 1 and PER 2

Table 1: Mandatory Technical Requirements (against Tender Requirements and Technical Specifications). Verification and consideration of the following: -

No	Criteria	REREC Requirement	Bidder's Offer – Yes or No
1	Valid ISO 9001:2015 certification	Applicable for goods manufactured outside Kenya	
2	Valid KEBS Diamond Mark of Quality Certificate or KEBS Standardization Mark Certificate	Applicable for goods manufactured in Kenya	
3	Type Test reports and certificates from the relevant International or National Testing/Standards Authority or ISO/IEC17025 accredited independent laboratory for full compliance with Tender Specifications.	Shall NOT be more than five (5) years old prior to the Date of the Tender document.	
4	Accreditation certificate for the testing laboratory to ISO/ IEC 17025 (<i>Applicable for firms without KEBS</i>)	Should be relevant to the tender and from designated body	
5	Drawings and Catalogues/Brochures	Relevancy to the Tender (Shall be those from the manufacturer/Tenderer)	
6	Full compliance of Guaranteed Technical Particulars	Required as per specifications	
7	Manufacturer's Guarantees and Warranty	Required in the format given in the Tender document	
8	Financial Statements	Valid ICPAK Practicing License and five year audited financial statement,	

Verification and consideration of the following: - Full compliance to the Schedule of Guaranteed Technical Particulars as per Technical Specifications

Table 2: Detailed Technical Requirements (against Tender Requirements and Technical Specifications).

	Criteria	RERER Requirement	Bidder's Offer – Yes or No
1	Full compliance to the Schedule of Guaranteed Technical Particulars (GTPs) as Technical Specifications	Required as per specifications	

Part 2: Further Technical Evaluation

These are mandatory requirements. The Tenderer shall provide duly filled Capacity Declaration Form from the manufacturer as per REREC requirements on manufacturer's letterhead and provide additional technical evidence (attach photos as proof where necessary) to facilitate determination of capacity responsiveness: -

Form 3.1 Manufacturer's Capacity Declaration Form

No.	Capacity Detail / Requirement	REREC Requirement	Manufacturer to indicate	Meets capacity (Yes / No)					
1	Monthly Production capacity	State capacity per item							
2	Delivery Period after issuance of Purchase Order (bidders to provide a fully filled GLT form)	State as provided in Schedule of requirement form							
3	No. of Ready Stocks (Attach a separate form showing individual items of ready stock)	State (if any)							
4	Valid Quality Certifications	Valid ISO 9001:2015 or ISO 14001:2015 or ISO 26000:2010 or ISO 45001:2018 or Type Test Reports							
5	Previous Four (4) Completed contracts in the last four years	Attach Evidence							
	No.	Contract Name	Date	Value (Kshs.)	Order Quantity	Quantity Delivered	% Delivered	Country	
	1.								
	2.								
	3.								
4.									
<i>Overall score</i>									

Part III – Financial Evaluation

Evaluation of the following Financial information against Tender Requirements and Specifications:

NO.	EVALUATION CRITERIA
7.3.1	a) Confirmation of the authenticity and sufficiency of the submitted Tender Security
	b) Confirmation of and considering schedule of rates and prices and/or priced Bill of Quantities duly completed and signed and stamped
	c) Checking that the Tenderer has quoted prices based on all costs including insurances, duties, levies, Value Added Tax (V.A.T), Withholding Tax and other taxes payable and delivery to the project sites
	d) Where applicable, Conducting a financial comparison,
	e) Taking into account the cost of any deviation(s) from the tender requirements
7.3.2	<p>Ascertaining the financial capability through Last Financial Year's audited financial statements issued within the last five (5) years which Statements should conform to International Accounting Standards One (IAS 1) which includes the following: -</p> <p>a) Turnover in the Last three (3) Financial Year i.e. thirty six (36) months of at least 30% of the total tendered value.</p> <p>b) Checking and considering that the Tenderer's solvency ratios are acceptable to REREC and meet the threshold of: - Solvency ratio of Debt to Assets Ratio which should be at least 1:1</p>
7.3.3	Provide documentary evidence of liquid assets and/or credit facilities, net of other contractual commitments and exclusive of any advance payments which may be made under the contract.
7.3.4	Considering information submitted in the Confidential Business Questionnaire against other information in the bid including declared maximum value of business.

*NOTES: -

1. For purposes of evaluation, the exchange rate to be used for currency conversion shall be the selling exchange rate prevailing on the date of tender closing provided by the Central Bank of Kenya. (Visit the Central Bank of Kenya website).
2. Total tender value means the Tenderer's total tender price inclusive of Value Added Tax (V.A.T) for the works it offers to provide.

a) History of non-performing contracts:

Tenderer and each member of JV in case the Tenderer is a JV, shall demonstrate that Non-performance of a contract did not occur because of the default of the Tenderer, or the member of a JV in the last Three (3) years The required information shall be furnished in the appropriate form.

b) Pending Litigation

Financial position and prospective long-term profitability of the Single Tenderer, and in the case the Tenderer is a JV, of each member of the JV, shall remain sound according to criteria established with respect to Financial Capability under Paragraph

(i) above i fall pending litigation will be resolved against the Tenderer. Tenderer shall provide information on pending litigations in the appropriate form.

c) Litigation History

There shall be no consistent history of court/ arbitral award decisions against the Tenderer, in the last Five (5) years. All parties to the contract shall furnish the information in the appropriate form about any litigation or arbitration resulting from contracts completed or ongoing under its execution over the years specified. A consistent history of awards against the Tenderer or any member of a JV may result (v)

1 MARGIN OF PREFERENCE: N/A

- 1.1 If the TDS so specifies, the Procuring Entity will grant a margin of preference of 15% (fifteen percent) to Tenderers offering goods manufactured, mined, extracted, grown, assembled or semi-processed in Kenya. Goods assembled or semi-processed in Kenya shall have a local content of not less than 40%.
- 1.2 The margin of preference will be applied in accordance with, and subject to, the following provisions:
 - a Tenderers applying for such preference on goods offered shall be asked to provide, as part of the data for qualification, such information, including details of the goods produced in Kenya, so as to determine whether, according to the classification established by the Procuring Entity, a particular category of goods or group of goods qualifies for a margin of preference.
 - b After Tenders have been received and reviewed by the Procuring Entity, goods offered in the responsive Tenders shall be assessed to ascertain they are manufactured, mined, extracted, grown, assembled or semi-processed in Kenya. Responsive tenders shall be classified in to the following groups:
 - i) **Group A:** Tenders offering goods manufactured in Kenya, for which (a) labor, raw materials, and components from within Kenya account for more than forty (40) percent of the Ex-Works price; and the production facility in which they will be manufactured or assembled has been engaged in manufacturing or assembling such goods at least since the date of Tender submission date;
 - ii) **Group B:** All other Tenders offering Goods manufactured in Kenya;
 - iii) **Group C:** Tenders offering Goods manufactured outside Kenya that have been already imported or that will be imported.
- 1.3 To facilitate this classification by the Procuring Entity, the tenderer shall complete whichever version of the Price Schedule furnished in the Tendering document is appropriate, provided however, that the completion of an incorrect version of the Price Schedule by the Tenderer shall not result in rejection of its Tender, but merely in the Procuring Entity's reclassification of the Tender into its appropriate Tender group.
- 1.4 The Tenders in each group will then be compared to determine the Tender with the lowest evaluated cost in that group. The lowest evaluated cost Tender from each group shall then be compared with each other and if as a result of this comparison a Tender from Group A or Group B is the lowest, it shall be selected for the award.
- 1.5 If as a result of the preceding comparison, a Tender from Group C is the lowest evaluated cost, an amount equal to or 15% of the respective tender price, including unconditional discounts and excluding provisional sums, if any, shall be added to the evaluated price offered in each tender from Group C. If the tender from Group C is still the lowest tender, it shall be selected for award. If not, the lowest evaluated tender from Group A or B based on the first evaluation price shall be selected.

2 Alternative Tenders (ITT 13.1)

Not Applicable

3 Post qualification and Contract award (ITT 39), more specifically,

- a) The contract shall be awarded to the lowest evaluated tenderer, subject to confirmation of post qualification data.
 - i) The Tenderer shall demonstrate that it has access to, or has available, liquid assets, unencumbered real assets, lines of credit, and other financial means (independent of any contractual advance payment) sufficient to meet the construction cash flow of Kenya Shillings

- ii) Minimum average annual construction turnover of Kenya Shillings 1.5 times the cost of the contract, equivalent calculated as total certified payments received for contracts in progress and/ or completed within the last seven (7) years.
- iii) At least Three (3) of contract (s) of a similar nature executed within Kenya, or the East African Community or abroad, that have been satisfactorily and substantially completed as a prime contractor, or joint venture member or sub-contractor each of minimum value Kenya shillings _____ equivalent.: N/A
- iv) Contractor's Representative and Key Personnel, which are specified as defined in 7.2 part II
- v) Contractors key equipment listed on the table "Contractor's Equipment" below and more specifically listed as *[specify requirements for each lot as applicable]* _____
- iv) Other conditions depending on their seriousness.
 - a) **History of non-performing contracts:**
Tenderer and each member of JV in case the Tenderer is a JV, shall demonstrate that Non- performance of a contract did not occur because of the default of the Tenderer, or the member of a JV in the last Five (5) The required information shall be furnished in the appropriate form.
 - b) **Pending Litigation**
Financial position and prospective long-term profitability of the Single Tenderer, and in the case the Tenderer is a JV, of each member of the JV, shall remain sound according to criteria established with respect to Financial Capability under Paragraph (i) above i fall pending litigation will be resolved against the Tenderer. Tenderer shall provide information on pending litigations in the appropriate form.
 - c) **Litigation History**
There shall be no consistent history of court/ arbitral award decisions against the Tenderer, in the last _____ (*specify years*). All parties to the contract shall furnish the information in the appropriate form about any litigation or arbitration resulting from contracts completed or ongoing under its execution over the years specified. A consistent history of awards against the Tenderer or any member of a JV may result in rejection of the tender.

8. Qualification

Factor	1 Eligibility					Documentation Required
Sub-Factor	Criteria					
	Requirement	Tenderer			Joint Venture (existing or intended)	
		Single Entity	All members combined	Each Partner		At least one Partner
1.1 Nationality	Nationality in accordance with ITT 4.6.	Must meet requirement	must meet requirement	Must meet requirement	N / A	Form ELI – 1.1 and 1.2, with attachments
1.2 Conflict of Interest	No- conflicts of interests as described in ITT 4.3	Must meet requirement	must meet requirement	Must meet requirement	N / A	Form of Tender
1.3 PPRA Ineligibility (if debarred/Sanctioned)	Not having been declared ineligible by the PPRA as described in 4.5.	Must meet requirement	must meet requirement	Must meet requirement	N / A	Form of Tender
1.4 State Owned Enterprise or Institution	Compliance with conditions of ITT 4.8	Must meet requirement	Must meet requirement	Must meet requirement	N / A	Form ELI – 1.1 and 1.2, with attachments
1.5 Ineligibility based on a United Nations resolution or Kenya laws	Not having been excluded as a result of the Kenya laws or official regulations, or by an act of compliance with UN Security Council resolution, in accordance with ITT 4.9 and Section V.	Must meet requirement	must meet requirement	Must meet requirement	N / A	Form of Tender
1.6 Tax Obligations for Kenyan Tenderers	Has produced a current tax clearance certificate or tax exemption certificate issued by the Kenya Revenue Authority in accordance with ITT 4.13.	Must meet requirement	must meet requirement	Must meet requirement	N / A	Attach certificate

Factor	2. Historical Contract Non-Performance					Documentation Required
Sub-Factor	Criteria	Tenderer				
	Requirement	Single Entity	Joint Venture (existing or intended)			
			All members combined	Each member	At least one member	
2.1 History of non-performing contracts	Non-performance ¹ of a contract did not occur within the last five (5) years prior to the deadline for application submission, based on all information on fully settled disputes or litigation. A fully settled dispute or litigation is one that has been resolved in accordance with the Dispute Resolution Mechanism under the respective contract, and where all appeal instances available to the Tenderer have been exhausted.	Must meet requirement by itself or as member to past or existing JV	N / A	Must meet requirement ²	N / A	Form CON - 2
2.2 Suspension	Not under suspension based on execution of a Tender Securing Declaration or Proposal Securing Declaration pursuant to ITT 4.7 and ITT 20.9	Must meet requirement	Must meet requirement	Must meet requirement	Must meet requirement	Form of Tender
2.2 Pending Litigation	Tender's financial position and prospective long-term profitability still sound according to criteria established in 3.1 below and assuming that all pending litigation will be resolved against the Tenderer	Must meet requirement	N / A	Must meet requirement	N / A	Form CON – 2
2.3 Litigation History	No consistent history of court/arbitral award decisions against the Tenderer ³ since 1 st January 2018]	Must meet requirement	Must meet requirement	Must meet requirement	N/A	Form CON – 2

¹ Nonperformance, as decided by the Procuring Entity, shall include all contracts where (a) nonperformance was not challenged by the contractor, including through referral to the dispute resolution mechanism under the respective contract, and (b) contracts that were so challenged but fully settled against the contractor. Nonperformance shall not include contracts where Procuring Entity's decision was overruled by the dispute resolution mechanism. Nonperformance must be based on all information on fully settled disputes or litigation, i.e. dispute or litigation that has been resolved in accordance with the dispute resolution mechanism under the respective contract and where all appeal instances available to the Tenderer have been exhausted.

² This requirement also applies to contracts executed by the Tenderer as JV member.

³ The Tenderer shall provide accurate information on the related Tender Form about any litigation or arbitration resulting from contracts completed or ongoing under its execution over the last five years. A consistent history of awards against the Tenderer or any member of a joint venture may result in failure of the Tender.

Factor		3 Financial Situation					
Sub-Factor	Criteria					Documentation Required	
	Requirement	Tenderer		Joint Venture (existing or intended)			
		Single Entity	All members combined	Each member	At least one member		
3.1 Financial Capabilities	Submission of audited balance sheets or if not required by the law of the Tenderer's Country, other financial statements acceptable to the Procuring Entity, for the last Five (5) years to demonstrate the current soundness of the Tenderers financial position and its prospective long-term profitability.	Must meet requirement	Must meet requirement	Must meet requirement	N / A	Form FIN – 3.1 with attachments	
3.2 Average Annual Turnover	Minimum average annual turnover in Energy Sector of Ksh 100,000,000 calculated as total certified payments received for contracts in progress or completed, within the last Five (5) years	Must meet requirement	Must meet requirement	N/A	Must meet Thirty percent (30%) of the requirement	Form FIN –3.2	
3.3 Financial Resources	The Tenderer must demonstrate access to, or availability of, financial resources such as liquid assets, unencumbered real assets, lines of credit, and other financial means, other than any contractual advance payments to meet: (i) the following cash-flow requirement: Ten Percent (10%) of contract sum across all lots and (ii) the overall cash flow requirements for this contract and its current commitments.	Must meet requirement	Must meet requirement	N/A	N/A	Form FIN –3.3	

Factor	4 Experience					Documentation Required
Sub-Factor	Criteria	Tenderer				
	Requirement	Single Entity	Joint Venture (existing or intended)			
			All members combined	Each member	At least one member	
4.1 General Experience	Experience in <i>Energy Sector</i> under contracts in the role of <i>contractor</i> , subcontractor, or management contractor for at least the last 5 years starting 1 st January 2019	Must meet requirement	Must meet requirement	N/A	Must meet requirement	Form EXP-4.1
4.2(a) Specific Experience	(a) Participation as contractor, joint venture member ⁴ , management contractor, or subcontractor, in at least three (3) contracts within the last five (5) years, each with a value of at least Ksh. 50,000,000 that have been successfully and substantially ⁵ completed and that are similar to the proposed Plant and Installation Services. The similarity of the contracts shall be based on the following: <i>[Based on Section VII, Scope of Works, specify the minimum key requirements in terms of physical size, complexity, construction method, technology and/or other characteristics Indicate, if any, of this key requirement may also be met through a specialized subcontractor.]</i>	Must meet requirement	Must meet requirements ⁶	N / A	Must meet requirement	Form EXP 4.2(a)
4.2(b) Specific Experience	(b) For the above or other contracts executed during the period stipulated in 4.2(a) above, a minimum experience in the following key activities:	Must meet requirements	Must meet requirements ⁷	N / A	Must meet requirement	Form EXP-4.2(b) Signed Contract letters, Completion /Handover

⁴ For contracts under which the Tenderer participated as a joint venture member or sub-contractor, only the Tenderer's share, by value, shall be considered to meet this requirement

⁵ Substantial completion shall be based on 80% or more plant and installation completed under the contract.

⁶ In the case of JV, the value of contracts completed by its members shall not be aggregated to determine whether the requirement of the minimum value of a single contract has been met. Instead, each contract performed by each member shall satisfy the minimum value of a single contract as required for single entity. In determining whether the JV meets the requirement of total number of contracts, only the number of contracts completed by all members each of value equal or more than the minimum value required shall be aggregated.

⁷ In the case of JV, the value of contracts completed by its members shall not be aggregated to determine whether the requirement of the minimum value of a single contract has been met. Instead, each contract performed by each member shall satisfy the minimum value of a single contract as required for single entity. In determining whether the JV meets the requirement of total number of contracts, only the number of contracts completed by all members each of value equal or more than the minimum value required shall be aggregated.

Factor	4 Experience					Documentation Required
Sub-Factor	Criteria					
	Requirement	Tenderer				
		Single Entity	Joint Venture (existing or intended)			
			All members combined	Each member	At least one member	
						certificates and Customer recommendations

Note: [For Multiple lots (contracts) specify financial and experience criteria for each lot under Sub-Factors 3.1, 3.2, 4.2(a) and 4.2(b)]

SECTION IV - TENDERING FORMS

QUALIFICATION FORMS

1. FOREIGN TENDERERS 40%RULE

Pursuant to ITT 3.9, a foreign tenderer must complete this form to demonstrate that the tender fulfils this condition.

ITEM	Description of Work Item	Describe location of Source	COST in K. shillings	Comments, if any
A	Local Labor			
1				
2				
3				
4				
5				
B	Sub contracts from Local sources			
1				
2				
3				
4				
5				
C	Local materials			
1				
2				
3				
4				
5				
D	Use of Local Plant and Equipment			
1				
2				
3				
4				
5				
E	Add any other items			
1				
2				
3				
4				
5				
6				
	TOTAL COST LOCAL CONTENT		XXXXX	
	PERCENTAGE OF CONTRACT PRICE			

2. FORM EQU: EQUIPMENT

The Tenderer shall provide adequate information to demonstrate clearly that it has the capability to meet the requirements for the key equipment listed in Section III, Evaluation and Qualification Criteria. A separate Form shall be prepared for each item of equipment listed, or for alternative equipment proposed by the Tenderer.

Item of equipment		
Equipment information	Name of manufacturer	Model and power rating
	Capacity	Year of manufacture
Current status	Current location	
	Details of current commitments	
Source	Indicate source of the equipment <input type="checkbox"/> Owned <input type="checkbox"/> Rented <input type="checkbox"/> Leased <input type="checkbox"/> Specially manufactured	

Omit the following information for equipment owned by the Tenderer.

Owner	Name of owner	
	Address of owner	
	Telephone	Contact name and title
	Fax	Telex
Agreements	Details of rental / lease / manufacture agreements specific to the project	

3. FORM PER -1

Contractor's Representative and Key Personnel Schedule

Tenderers should provide the names and details of the suitably qualified Contractor's Representative and Key Personnel to perform the Contract. The data on their experience should be supplied using the Form PER-2 below for each candidate.

Contractor' Representative and Key Personnel

1.	Title of position: Contractor's Representative	
	Name of candidate:	
	Duration of appointment:	<i>[insert the whole period (start and end dates) for which this position will be engaged]</i>
	Time commitment: for this position:	<i>[insert the number of days/week/months/ that has been scheduled for this position]</i>
	Expected time schedule for this position:	<i>[insert the expected time schedule for this position (e.g. attach high level Gantt chart]</i>
2.	Title of position: []	
	Name of candidate:	
	Duration of appointment:	<i>[insert the whole period (start and end dates) for which this position will be engaged]</i>
	Time commitment: for this position:	<i>[insert the number of days/week/months/ that has been scheduled for this position]</i>
	Expected time schedule for this position:	<i>[insert the expected time schedule for this position (e.g. attach high level Gantt chart]</i>
3.	Title of position: []	
	Name of candidate:	
	Duration of appointment:	<i>[insert the whole period (start and end dates) for which this position will be engaged]</i>
	Time commitment: for this position:	<i>[insert the number of days/week/months/ that has been scheduled for this position]</i>
	Expected time schedule for this position:	<i>[insert the expected time schedule for this position (e.g. attach high level Gantt chart]</i>
4.	Title of position: []	
	Name of candidate:	
	Duration of appointment:	<i>[insert the whole period (start and end dates) for which this position will be engaged]</i>
	Time commitment: for this position:	<i>[insert the number of days/week/months/ that has been scheduled for this position]</i>
	Expected time schedule for this position:	<i>[insert the expected time schedule for this position (e.g. attach high level Gantt chart]</i>
5.	Title of position: <i>[insert title]</i>	
	Name of candidate	
	Duration of appointment:	<i>[insert the whole period (start and end dates) for which this position will be engaged]</i>
	Time commitment: for this position:	<i>[insert the number of days/week/months/ that has been scheduled for this position]</i>
	Expected time schedule for this position:	<i>[insert the expected time schedule for this position (e.g. attach high level Gantt chart]</i>

4. FORM PER - 2:

Resume and Declaration - Contractor's Representative and Key Personnel.

Name of Tenderer

Position [# 1]: <i>[title of position from Form PER-1]</i>		
Personnel information	Name:	Date of birth:
	Address:	E-mail:
	Professional qualifications:	
	Academic qualifications:	
	Language proficiency: <i>[language and levels of speaking, reading and writing skills]</i>	
Details	Address of Procuring Entity:	
	Telephone:	Contact (manager / personnel officer):
	Fax:	
	Job title:	Years with present Procuring Entity:

Summarize professional experience in reverse chronological order. Indicate particular technical and managerial experience relevant to the project.

Project	Role	Duration of involvement	Relevant experience
<i>[main project details]</i>	<i>[role and responsibilities on the project]</i>	<i>[time in role]</i>	<i>[describe the experience relevant to this position]</i>

Declaration

I, the undersigned [*insert either "Contractor's Representative" or "Key Personnel" as applicable*], certify that to the best of my knowledge and belief, the information contained in this Form PER-2 correctly describes myself, my qualifications and my experience.

I confirm that I am available as certified in the following table and throughout the expected time schedule for this position as provided in the Tender:

Commitment	Details
Commitment to duration of contract:	<i>[insert period (start and end dates) for which this Contractor's Representative or Key Personnel is available to work on this contract]</i>
Time commitment:	<i>[insert period (start and end dates) for which this Contractor's Representative or Key Personnel is available to work on this contract]</i>

I understand that any misrepresentation or omission in this Form may:

- (a) be taken into consideration during Tender evaluation;
- (b) result in my disqualification from participating in the Tender;
- (c) result in my dismissal from the contract.

Name of Contractor's Representative or Key Personnel: [*insert name*]

Signature: _____

Date: (day month year): _____

Countersignature of authorized representative of the Tenderer:

Signature: _____

Date: (day month year): _____

5. TENDERERS QUALIFICATION WITHOUT PREQUALIFICATION

To establish its qualifications to perform the contract in accordance with Section III, Evaluation and Qualification Criteria the Tenderer shall provide the information requested in the corresponding Information Sheets included hereunder.

5.1 FORM ELI -1.1

Tenderer Information Form

Date: _____

ITT No. and title: _____

Tenderer's name
In case of Joint Venture (JV), name of each member:
Tenderer's actual or intended country of registration: <i>[indicate country of Constitution]</i>
Tenderer's actual or intended year of incorporation:
Tenderer's legal address [in country of registration]:
Tenderer's authorized representative information Name: _____ Address: _____ Telephone/Fax numbers: _____ E-mail address: _____
1. Attached are copies of original documents of <input type="checkbox"/> Articles of Incorporation (or equivalent documents of constitution or association), and/or documents of registration of the legal entity named above, in accordance with ITT 3.6 <input type="checkbox"/> In case of JV, letter of intent to form JV or JV agreement, in accordance with ITT 3.5 <input type="checkbox"/> In case of state-owned enterprise or institution, in accordance with ITT 3.8, documents establishing: <ul style="list-style-type: none"> • Legal and financial autonomy • Operation under commercial law <ol style="list-style-type: none"> 1. Establishing that the Tenderer is not under the supervision of the Procuring Entity 2. Included are the organizational chart and a list of Board of Directors

5.2 FORM ELI -1.2

Tenderer's JV Information Form

(to be completed for each member of Tenderer's JV)

Date: _____

ITT No. and title: _____

Tenderer's JV name:
JV member's name:
JV member's country of registration:
JV member's year of constitution:
JV member's legal address in country of constitution:
JV member's authorized representative information Name: _____ Address: _____ Telephone/Fax numbers: _____ E-mail address: _____
1. Attached are copies of original documents of <input type="checkbox"/> Articles of Incorporation (or equivalent documents of constitution or association), and/or registration documents of the legal entity named above, in accordance with ITT 3.6. <input type="checkbox"/> In case of a state-owned enterprise or institution, documents establishing legal and financial autonomy, operation in accordance with commercial law, and that they are not under the supervision of the Procuring Entity, in accordance with ITT 3.5.
2. Included are the organizational chart and a list of Board of Directors.

5.3 FORM CON -2

Historical Contract Non-Performance, Pending Litigation and Litigation History

Tenderer's Name: _____

Date: _____

JV Member's Name _____

ITT No. and title: _____

Non-Performed Contracts in accordance with Section III, Evaluation and Qualification Criteria			
<input type="checkbox"/> Contract non-performance did not occur since 1 st January <i>[insert year]</i> specified in Section III, Evaluation and Qualification Criteria, Sub-Factor 2.1.			
<input type="checkbox"/> Contract(s) not performed since 1 st January <i>[insert year]</i> specified in Section III, Evaluation and Qualification Criteria, requirement 2.1			
<input type="checkbox"/> Contract(s) withdrawn since 1 st January <i>[insert year]</i> specified in Section III, Evaluation and Qualification Criteria, requirement 2.1			
Year	Non- performed portion of contract	Contract Identification	Total Contract Amount (current value, currency, exchange rate and Kenya Shilling equivalent)
<i>[insert year]</i>	<i>[insert amount and percentage]</i>	Contract Identification: <i>[indicate complete contract name/ number, and any other identification]</i> Name of Procuring Entity: <i>[insert full name]</i> Address of Procuring Entity: <i>[insert street/city/country]</i> Reason(s) for nonperformance: <i>[indicate main reason(s)]</i>	<i>[insert amount]</i>
Pending Litigation, in accordance with Section III, Evaluation and Qualification Criteria			
<input type="checkbox"/> No pending litigation in accordance with Section III, Evaluation and Qualification Criteria, Sub-Factor 2.3.			
<input type="checkbox"/> Pending litigation in accordance with Section III, Evaluation and Qualification Criteria, Sub-Factor 2.3 as indicated below.			

Year of dispute	Amount in dispute (currency)	Contract Identification	Total Contract Amount (currency), Kenya Shilling Equivalent (exchange rate)
		Contract Identification: _____ Name of Procuring Entity: _____ Address of Procuring Entity: _____ Matter in dispute: _____ Party who initiated the dispute: _____ Status of dispute: _____	
		Contract Identification: _____ Name of Procuring Entity: _____ Address of Procuring Entity: _____ Matter in dispute: _____ Party who initiated the dispute: _____ Status of dispute: _____	
Litigation History in accordance with Section III, Evaluation and Qualification Criteria			
<input type="checkbox"/> No Litigation History in accordance with Section III, Evaluation and Qualification Criteria, Sub-Factor 2.4. <input type="checkbox"/> Litigation History in accordance with Section III, Evaluation and Qualification Criteria, Sub-Factor 2.4 as indicated below.			
<i>[insert year]</i>	<i>[insert percentage]</i>	Contract Identification: [indicate complete contract name, number, and any other identification] Name of Procuring Entity: <i>[insert full name]</i> Address of Procuring Entity: <i>[insert street/city/country]</i> Matter in dispute: <i>[indicate main issues in dispute]</i> Party who initiated the dispute: <i>[indicate "Procuring Entity" or "Contractor"]</i> Reason(s) for Litigation and award decision <i>[indicate main reason(s)]</i>	<i>[insert amount]</i>

Include details relating to potential bid-rigging practices such as previous occasions where tenders were withdrawn, joint bids with competitors, subcontracting work to unsuccessful tenderers, etc.

5.4 FORM FIN – 3.1:

Financial Situation and Performance

Tenderer's Name: _____

Date: _____

JV Member's Name _____

ITT No. and title: _____

5.4.1. Financial Data

Type of Financial information in _____ (currency)	Historic information for previous _____ years, (amount in currency, currency, exchange rate*, USD equivalent)				
	Year 1	Year 2	Year 3	Year 4	Year 5
Statement of Financial Position (Information from Balance Sheet)					
Total Assets (TA)					
Total Liabilities (TL)					
Total Equity/Net Worth (NW)					
Current Assets (CA)					
Current Liabilities (CL)					
Working Capital (WC)					
Information from Income Statement					
Total Revenue (TR)					
Profits Before Taxes (PBT)					
Cash Flow Information					
Cash Flow from Operating Activities					

*Refer to ITT 15 for the exchange rate

5.4.2 Sources of Finance

Specify sources of finance to meet the cash flow requirements on works currently in progress and for future contract commitments.

No.	Source of finance	Amount (Kenya Shilling equivalent)
1		
2		
3		

5.4.3 Financial documents

The Tenderer and its parties shall provide copies of financial statements for _____ years pursuant Section III, Evaluation and Qualifications Criteria, Sub-factor 3.1. The financial statements shall:

- (a) reflect the financial situation of the Tenderer or in case of JV member, and not an affiliated entity (such as parent company or group member).
- (b) be independently audited or certified in accordance with local legislation.
- (c) be complete, including all notes to the financial statements.
- (d) correspond to accounting periods already completed and audited.

Attached are copies of financial statements⁸ for the _____ years required above; and complying with the requirements

⁸ If the most recent set of financial statements is for a period earlier than 12 months from the date of Tender, the reason for this should be justified.

5.5 FORM FIN – 3.2:

Average Annual Construction Turnover

Tenderer's Name: _____

Date: _____

JV Member's Name _____

ITT No. and title: _____

Annual turnover data (construction only)			
Year	Amount Currency	Exchange rate	Kenya Shilling equivalent
<i>[indicate year]</i>	<i>[insert amount and indicate currency]</i>		
Average Annual Construction Turnover *			

* See Section III, Evaluation and Qualification Criteria, Sub-Factor 3.2.

5.6 FORM FIN – 3.3:

Financial Resources

Specify proposed sources of financing, such as liquid assets, unencumbered real assets, lines of credit, and other financial means, net of current commitments, available to meet the total construction cash flow demands of the subject contract or contracts as specified in Section III, Evaluation and Qualification Criteria

Financial Resources		
No.	Source of financing	Amount (Kenya Shilling equivalent)
1		
2		
3		

5.7 FORM FIN – 3.4:

Current Contract Commitments / Works in Progress

Tenderers and each member to a JV should provide information on their current commitments on all contracts that have been awarded, or for which a letter of intent or acceptance has been received, or for contracts approaching completion, but for which an unqualified, full completion certificate has yet to be issued.

Current Contract Commitments					
No.	Name of Contract	Procuring Entity's Contact Address, Tel,	Value of Outstanding Work [Current Kenya Shilling /month Equivalent]	Estimated Completion Date	Average Monthly Invoicing Over Last Six Months [Kenya Shilling /month)]
1					
2					
3					
4					
5					

5.8 FORM EXP - 4.1

General Construction Experience

Tenderer's Name: _____

Date: _____

JV Member's Name _____

ITT No. and title: _____

Page _____ of _____ pages

Starting Year	Ending Year	Contract Identification	Role of Tenderer
		Contract name: _____ Brief Description of the Works performed by the Tenderer: _____ Amount of contract: _____ Name of Procuring Entity: _____ Address: _____	
		Contract name: _____ Brief Description of the Works performed by the Tenderer: _____ Amount of contract: _____ Name of Procuring Entity: _____ Address: _____	
		Contract name: _____ Brief Description of the Works performed by the Tenderer: _____ Amount of contract: _____ Name of Procuring Entity: _____ Address: _____	

5.9 FORM EXP - 4.2(a)

Specific Construction and Contract Management Experience

Tenderer's Name: _____

Date: _____

JV Member's Name _____

ITT No. and title: _____

Similar Contract No.	Information			
Contract Identification				
Award date				
Completion date				
Role in Contract	Prime Contractor <input type="checkbox"/>	Member in JV <input type="checkbox"/>	Management Contractor <input type="checkbox"/>	Sub-contractor <input type="checkbox"/>
Total Contract Amount				Kenya Shilling
If member in a JV or sub-contractor, specify participation in total Contract amount				
Procuring Entity's Name:				
Address:				
Telephone/fax number				
E-mail:				

5.9 FORM EXP - 4.2(a)

Specific Construction and Contract Management Experience

Tenderer's Name: _____

Date: _____

JV Member's Name _____

ITT No. and title: _____

Similar Contract No.	Information			
Contract Identification				
Award date				
Completion date				
Role in Contract	Prime Contractor <input type="checkbox"/>	Member in JV <input type="checkbox"/>	Management Contractor <input type="checkbox"/>	Sub-contractor <input type="checkbox"/>
Total Contract Amount				Kenya Shilling
If member in a JV or sub-contractor, specify participation in total Contract amount				
Procuring Entity's Name:				
Address:				
Telephone/fax number				
E-mail:				

5.9 FORM EXP - 4.2 (a) (cont.)

Specific Construction and Contract Management Experience (cont.)

Similar Contract No.	Information
Description of the similarity in accordance with Sub-Factor 4.2(a) of Section III:	
1. Amount	
2. Physical size of required works items	
3. Complexity	
4. Methods/Technology	
5. Construction rate for key activities	
6. Other Characteristics	

5.10 FORM EXP - 4.2(b)

Construction Experience in Key Activities

Tenderer's Name: _____

Date: _____

Tenderer's JV Member Name: _____

Sub-contractor's Name⁹ (as per ITT 34): _____

ITT No. and title: _____

All Sub-contractors for key activities must complete the information in this form as per ITT 34 and Section III, Evaluation and Qualification Criteria, Sub-Factor 4.2.

1. Key Activity No One: _

Information				
Contract Identification				
Award date				
Completion date				
Role in Contract	Prime Contractor <input type="checkbox"/>	Member in JV <input type="checkbox"/>	Management Contractor <input type="checkbox"/>	Sub-contractor <input type="checkbox"/>
Total Contract Amount	Kenya Shilling			
Quantity (Volume, number or rate of production, as applicable) performed under the contract per year or part of the year	Total quantity in the contract (i)	Percentage participation (ii)		Actual Quantity Performed (i) x (ii)
Year 1				
Year 2				
Year 3				
Year 4				
Procuring Entity's Name:				
Address: Telephone/fax number E-mail:				

⁹ If applicable

	Information
Description of the key activities in accordance with Sub-Factor 4.2(b) of Section III:	

- 2. Activity No. Two
- 3.

SECTION IV - OTHER FORMS

1. FORM OF TENDER

(Amended and issued pursuant to PPRA CIRCULAR No. 02/2022)

INSTRUCTIONS TO TENDERERS

i) All italicized text is to help the Tenderer in preparing this form.

ii) The Tenderer must prepare this Form of Tender on stationery with its letterhead clearly showing the Tenderer's complete name and business address. Tenderers are reminded that this is a mandatory requirement.

iii) Tenderer must complete and sign CERTIFICATE OF INDEPENDENT TENDER DETERMINATION and the SELF DECLARATION FORMS OF THE TENDERER as listed under (s) below.

Date of this Tender submission:.....*[insert date (as day, month and year) of Tender submission]*

Tender Name and Identification:.....*[insert identification]*

Alternative No.:.....*[insert identification No if this is a Tender for a alternative]*

To: *[Insert complete name of Procuring Entity]*

- a) **No reservations:** We have examined and have no reservations to the Tendering document, including Addenda issued in accordance with ITT 8;
- b) **Eligibility:** We meet the eligibility requirements and have no conflict of interest in accordance with ITT 4;
- c) **Tender-Securing Declaration:** We have not been suspended nor declared ineligible by the Procuring Entity based on execution of a Tender Securing Declaration or Proposal-Securing Declaration in Kenya in accordance with ITT 4.7;
- d) **Conformity:** We offer to provide design, supply and installation services in conformity with the Tendering document of the following: *[insert a brief description of the Plant, Design, Supply and Installation Services];*
- e) **Tender Price:** The total price of our Tender, excluding any discounts offered in item (f) below is: *[Insert one of the options below as appropriate]*

Option 1, in case of one lot: Total price is: *[insert the total price of the Tender in words and figures, indicating the various amounts and the respective currencies];*
Or Option 2, in case of multiple lots: (a) Total price of each lot *[insert the total price of each lot in words and figures, indicating the various amounts and the respective currencies];* and (b) Total price of all lots (sum of all lots) *[insert the total*

price of all lots in words and figures, indicating the various amounts and the respective currencies];

- f) **Discounts:** The discounts offered and the methodology for their application are:
 - i) The discounts offered are: *[Specify in detail each discount offered.]*
 - ii) The exact method of calculations to determine the net price after application of discounts is shown below:
[Specify in detail the method that shall be used to apply the discounts];
- g) **Tender Validity Period:** Our Tender shall be valid for the period specified in TDS 19.1 (as amended if applicable) from the date fixed for the Tender submission deadline specified in TDS 23.1 (as amended if applicable), and it shall remain binding upon us and may be accepted at any time before the expiration of that period;
- h) **Performance Security:** If our Tender is accepted; we commit to obtain a Performance Security in accordance with the Tendering document;
- i) **One Tender Per Tenderer:** We are not submitting any other Tender (s) as an individual Tenderer, and we are not participating in any other Tender (s) as a Joint Venture member, and meet the requirements of ITT 4.3, other than alternative Tenders submitted in accordance with ITT 13;
- j) **Suspension and Debarment:** We, along with any of our subcontractors, suppliers, consultants, manufacturers, or service providers for any part of the contract, are not subject to, and not controlled by any entity or individual that is subject to, a temporary suspension. Further, we are not ineligible under the Kenya laws or official regulations or pursuant to a decision of the United Nations Security Council;
- k) **State-owned enterprise or institution:** *[select the appropriate option and delete the other]* [We are not a state- owned enterprise or institution]/ [We are a state-owned enterprise or institution but meet the requirements of ITT 4.6];
- l) **Commissions, gratuities and fees:** We have paid, or will pay the following commissions, gratuities, or fees with respect to the Tendering process or execution of the Contract: [insert complete name of each Recipient, its full address, the reason for which each commission or gratuity was paid and the amount and currency of each such commission or gratuity]

Name of Recipient	Address	Reason	Amount

(If none has been paid or is to be paid, indicate "none.")

- m) **Binding Contract:** We understand that this Tender, together with your written acceptance thereof included in your Form of Acceptance, shall constitute a binding contract between us, until a formal contract is prepared and executed;
- n) **Not Bound to Accept:** We understand that you are not bound to accept the lowest evaluated cost Tender, the Best Evaluated Tender or any other Tender that you may receive; and
- o) **Fraud and Corruption:** We hereby certify that we have taken steps to ensure that no person acting for us or on our behalf engages in any type of Fraud and Corruption.

- p) Collusive practices: We hereby certify and confirm that the tender is genuine, non-collusive and made with the intention of accepting the contract if awarded. To this effect we have signed the “Certificate of Independent tender Determination” attached below.
- q) Code of Ethical Conduct: We undertake to adhere by the Code of Ethical Conduct for Persons Participating in Public Procurement and Asset Disposal Activities in Kenya, copy available from www.pppra.go.ke during the procurement process and the execution of any resulting contract.
- r) **Beneficial Ownership Information:** We commit to provide to the procuring entity the Beneficial Ownership Information in conformity with the Beneficial Ownership Disclosure Form upon receipt of notification of intention to enter into a contract in the event we are the successful tenderer in this subject procurement proceeding.
- s) We, the Tenderer, have duly completed, signed and stamped the following Forms as part of our Tender:
- (i) Tenderer’s Eligibility; Confidential Business Questionnaire – to establish we are not in any conflict to interest.
 - (ii) Certificate of Independent Tender Determination – to declare that we completed the tender without colluding with other tenderers.
 - (iii) Self-Declaration of the Tenderer – to declare that we will, if awarded a contract, not engage in any form of fraud and corruption.
 - (iv) declaration and commitment to the code of ethics for Persons Participating in Public Procurement and Asset Disposal Activities in Kenya,
- t) Further, we confirm that we have read and understood the full content and scope of fraud and corruption as informed in “**Appendix 1- Fraud and Corruption**” attached to the Form of Tender.

Name of the Tenderer: **[insert complete name of person signing the Tender]*

Name of the person duly authorized to sign the Tender on behalf of the Tenderer: ***[insert complete name of person duly authorized to sign the Tender]*

Title of the person signing the Tender: *[insert complete title of the person signing the Tender]*

Signature of the person named above: *[insert signature of person whose name and capacity are shown above]*

Date signed *[insert date of signing]* day of *[insert month]*, *[insert year]*.

*: In the case of the Tender submitted by a Joint Venture specify the name of the Joint Venture as tenderer.

** : Person signing the Tender shall have the power of attorney given by the tenderer. The power of attorney shall be attached with the Tender Schedules.

TENDERER'S ELIGIBILITY - CONFIDENTIAL BUSINESS QUESTIONNAIRE

Instruction to Tenderer

Tender is instructed to complete the particulars required in this Form, one form for each entity if Tender is a JV. Tenderer is further reminded that it is an offence to give false information on this Form.

a) Tenderer's details

	ITEM	DESCRIPTION
1	Name of the Procuring Entity	
2	Reference Number of the Tender	
3	Date and Time of Tender Opening	
4	Name of the Tenderer	
5	Full Address and Contact Details of the Tenderer.	1. Country 2. City 3. Location 4. Building 5. Floor 6. Postal Address 7. Name and email of contact person.
6	Current Trade License Registration Number and Expiring date	
7	Name, country and full address (<i>postal and physical addresses, email, and telephone number</i>) of Registering Body/Agency	
8	Description of Nature of Business	
9	Maximum value of business which the Tenderer handles.	
10	State if Tenders Company is listed in stock exchange, give name and full address (<i>postal and physical addresses, email, and telephone number</i>) of state which stock exchange	

General and Specific Details

b) Sole Proprietor, provide the following details.

Name in full _____ Age _____

Nationality _____ Country of Origin _____

Citizenship _____

c) Partnership, provide the following details.

	Names of Partners	Nationality	Citizenship	% Shares owned
1				
2				
3				

d) Registered Company, provide the following details.

i) Private or public Company _____

ii) State the nominal and issued capital of the Company: -

Nominal Kenya Shillings (Equivalent) _____

Issued Kenya Shillings (Equivalent) _____

iii) Give details of Directors as follows.

	Names of Director	Nationality	Citizenship	% Shares owned
1				
2				
3				

e) DISCLOSURE OF INTEREST-Interest of the Firm in the Procuring Entity.

i) Are there any person/ persons in.....(Name of Procuring Entity) who has/ have an interest or relationship in this firm?

Yes/No..... If yes, provide details as follows.

	Names of Person	Designation in the Procuring Entity	Interest or Relationship with Tenderer
1			
2			
3			

ii) Conflict of interest disclosure

	Type of Conflict	Disclosure YES OR NO	If YES provide details of the relationship with Tenderer
1	Tenderer is directly or indirectly controls, is controlled by or is under common control with another tenderer.		
2	Tenderer receives or has received any direct or indirect subsidy from another tenderer.		
3	Tenderer has the same legal representative as another tenderer		
4	Tender has a relationship with another tenderer, directly or through common third parties, that puts it in a position to influence the tender of another tenderer, or influence the decisions of the Procuring Entity regarding this tendering process.		
5	Any of the Tenderer's affiliates participated as a consultant in the preparation of the design or technical specifications of the works that are the subject of the tender.		
6	Tenderer would be providing goods, works, non-consulting services or consulting services during		

	Type of Conflict	Disclosure YES OR NO	If YES provide details of the relationship with Tenderer
	implementation of the contract specified in this Tender Document.		
7	Tenderer has a close business or family relationship with a professional staff of the Procuring Entity who are directly or indirectly involved in the preparation of the Tender document or specifications of the Contract, and/or the Tender evaluation process of such contract.		
8	Tenderer has a close business or family relationship with a professional staff of the Procuring Entity who would be involved in the implementation or supervision of the such Contract.		
9	Has the conflict stemming from such relationship stated in item 7 and 8 above been resolved in a manner acceptable to the Procuring Entity throughout the tendering process and execution of the Contract.		

f) Certification

On behalf of the Tenderer, I certify that the information given above is complete, current and accurate as at the date of submission.

Full Name _____

Title or Designation _____

(Signature)

(Date)

CERTIFICATE OF INDEPENDENT TENDER DETERMINATION

I, the under signed, in submitting the accompanying Letter of Tender to the _____ *[Name of Procuring Entity]* for: _____ *[Name and number of tender]* in response to the request for tenders made by: _____ *[Name of Tenderer]* do here by make the following statements that I certify to be true and complete in every respect:

I certify, on behalf of _____ *[Name of Tenderer]* that:

1. I have read and I understand the contents of this Certificate;
2. I understand that the Tender will be disqualified if this Certificate is found not to be true and complete in every respect;
3. I am the authorized representative of the Tenderer with authority to sign this Certificate, and to submit the Tender on behalf of the Tenderer;
4. For the purposes of this Certificate and the Tender, I understand that the word “competitor” shall include any individual or organization, other than the Tenderer, whether or not affiliated with the Tenderer, who:
 - a) Has been requested to submit a Tender in response to this request for tenders;
 - b) could potentially submit a tender in response to this request for tenders, based on their qualifications, abilities or experience;
5. The Tenderer discloses that [check one of the following, as applicable]:
 - a) The Tenderer has arrived at the Tender independently from, and without consultation, communication, agreement or arrangement with, any competitor;
 - b) The Tenderer has entered into consultations, communications, agreements or arrangements with one or more competitors regarding this request for tenders, and the Tenderer discloses, in the attached document(s), complete details thereof, including the names of the competitors and the nature of, and reasons for, such consultations, communications, agreements or arrangements;
6. In particular, without limiting the generality of paragraphs (5) (a) or (5) (b) above, there has been no consultation, communication, agreement or arrangement with any competitor regarding:
 - a) prices;
 - b) methods, factors or formulas used to calculate prices;
 - c) the intention or decision to submit, or not to submit, a tender; or
 - d) the submission of a tender which does not meet the specifications of the request for Tenders; except as specifically disclosed pursuant to paragraph (5) (b) above;
7. In addition, there has been no consultation, communication, agreement or arrangement with any competitor regarding the quality, quantity, specifications or delivery particulars of the works or services to which this request for tenders relates, except as specifically authorized by the procuring authority or as specifically disclosed pursuant to paragraph (5) (b) above;

8. The terms of the Tender have not been, and will not be, knowingly disclosed by the Tenderer, directly or indirectly, to any competitor, prior to the date and time of the official tender opening, or of the awarding of the Contract, whichever comes first, unless otherwise required by law or as specifically disclosed pursuant to paragraph (5) (b) above.

Name

Title

Date

[Name, title and signature of authorized agent of Tenderer and Date]

SELF DECLARATION FORMS

FORM SD1

SELF DECLARATION THAT THE PERSON /TENDERER IS NOT DEBARRED IN THE MATTER OF THE PUBLIC PROCUREMENT AND ASSET DISPOSAL ACT 2015.

I,, of Post Office Box being a resident of in the Republic of do hereby make a statement as follows: -

1. THAT I am the Company Secretary/ Chief Executive/ Managing Director/ Principal Officer/ Director of (*insert name of the Company*) who is a Bidder in respect of Tender No. for (*insert tender title/description*) for (*insert name of the Procuring entity*) and duly authorized and competent to make this statement.
2. THAT the afore said Bidder, its Directors and subcontractors have not been debarred from participating in procurement proceeding under Part IV of the Act.
3. THAT what is deponed to here in above is true to the best of my knowledge, information and belief.

(Title)

(Signature)

(Date)

Bidder's Official Stamp

FORM SD2

SELF DECLARATION THAT THE PERSON/TENDERER WILL NOT ENGAGE IN ANY CORRUPT OR FRAUDULENT PRACTICE.

I,of P. O. Box.....being a resident ofin the Republic of..... do hereby make a statement as follows: -

- 1. THAT I am the Chief Executive/ Managing Director/ Principal Officer/ Director of..... (insert name of the Company) who is a Bidder in respect of Tender No. for (insert tender title/description) for (insert name of the Procuring entity) and duly authorized and competent to make this statement.
2. THAT the afore said Bidder, its servants and/ or agents/ subcontractors will not engage in any corrupt or fraudulent practice and has not been requested to pay any inducement to any member of the Board, Management, Staff and/or employees and/or agents of (insert name of the Procuring entity) which is the procuring entity.
3. THAT the aforesaid Bidder, its servants and/ or agents/ subcontractor shave not offered any inducement to any member of the Board, Management, Staff and/ or employees and/ or agents of (name of the procuring entity).
4. THAT the aforesaid Bidder will not engage/ has not engaged in any corrosive practice with other bidders participating in the subject tender.
5. THAT what is deponed to here in above is true to the best of my knowledge information and belief.

..... (Title) (Signature) (Date)

Bidder's Official Stamp

DECLARATION AND COMMITMENT TO THE CODE OF ETHICS

I,
..... (P
erson) on behalf of
(Name of the Business/ Company/ Firm) declare that I have
read and fully understood the contents of the Public Procurement & Asset Disposal Act, 2015, Regulations
and the Code of Ethics for persons participating in Public Procurement and Asset Disposal and my
responsibilities under the Code.

I do hereby commit to abide by the provisions of the Code of Ethics for persons participating in Public
Procurement and Asset Disposal.

Name of Authorized signatory.....

Sign.....
....

Position.....
...

Office address.....Telephone.....

E-
mail.....
.

Name of the Firm/Company.....

Date.....

(Company Seal/ Rubber Stamp where applicable)

Witness

Name.....
.....

Sign.....
.....

Date.....
.....

APPENDIX 1 - FRAUD AND CORRUPTION

1. Purpose

- 1.1 The Government of Kenya's Anti-Corruption and Economic Crime laws and their sanction's policies and procedures, Public Procurement and Asset Disposal Act (*no. 33 of 2015*) and its Regulation, and any other Kenya's Acts or Regulations related to Fraud and Corruption, and similar offences, shall apply with respect to Public Procurement Processes and Contracts that are governed by the laws of Kenya.

2. Requirements

- 2.1 The Government of Kenya requires that all parties including Procuring Entities, Tenderers, (applicants/proposers), Consultants, Contractors and Suppliers; any Sub-contractors, Sub-consultants, Service providers or Suppliers; any Agents (whether declared or not); and any of their Personnel, involved and engaged in procurement under Kenya's Laws and Regulation, observe the highest standard of ethics during the procurement process, selection and contract execution of all contracts, and refrain from Fraud and Corruption and fully comply with Kenya's laws and Regulations as per paragraphs 1.1 above.
- 2.2 Kenya's public procurement and asset disposal act (*no. 33 of 2015*) under Section 66 describes rules to be followed and actions to be taken in dealing with Corrupt, Coercive, Obstructive, Collusive or Fraudulent practices, and Conflicts of Interest in procurement including consequences for offences committed. A few of the provisions noted below highlight Kenya's policy of no tolerance for such practices and behavior:
 - 1) A person to whom this Act applies shall not be involved in any corrupt, coercive, obstructive, collusive or fraudulent practice; or conflicts of interest in any procurement or as set disposal proceeding;
 - 2) A person referred to under subsection (1) who contravenes the provisions of that sub-section commits an offence;
 - 3) Without limiting the generality of the subsection (1) and (2), the person shall be: -
 - a) disqualified from entering into a contract for a procurement or asset disposal proceeding; or
 - b) if a contract has already been entered into with the person, the contract shall be voidable;
 - 4) The voiding of a contract by the procuring entity under subsection (7) does not limit any legal remedy the procuring entity may have;
 - 5) An employee or agent of the procuring entity or a member of the Board or committee of the procuring entity who has a conflict of interest with respect to a procurement: -
 - a) Shall not take part in the procurement proceedings;
 - b) shall not, after a procurement contract has been entered in to, take part in any decision relating to the procurement or contract; and
 - c) shall not be a subcontractor or for the tender to whom was awarded contract, or a member of the group of tenderers to whom the contract was awarded, but the subcontractor appointed shall meet all the requirements of this Act.
 - 6) An employee, agent or member described in subsection (1) who refrains from doing anything prohibited under that subsection, but for that subsection, would have been within his or her duties shall disclose the conflict of interest to the procuring entity;
 - 7) If a person contravenes subsection (1) with respect to a conflict of interest described in subsection

(5)(a) and the contract is awarded to the person or his relative or to another person in whom one of them had a direct or indirect pecuniary interest, the contract shall be terminated and all costs incurred by the public entity shall be made good by the awarding officer. Etc.

3. In compliance with Kenya's laws, regulations and policies mentioned above, the Procuring Entity:

a) Defines broadly, for the purposes of the above provisions, the terms set forth below as follows:

- i) "corrupt practice" is the offering, giving, receiving, or soliciting, directly or indirectly, of anything of value to influence improperly the actions of another party;
- ii) "fraudulent practice" is any act or omission, including misrepresentation, that knowingly or recklessly misleads, or attempts to mislead, a party to obtain financial or other benefit or to avoid an obligation;
- iii) "collusive practice" is an arrangement between two or more parties designed to achieve an improper purpose, including to influence improperly the actions of another party; "coercive practice" is impairing or harming, or threatening to impair or harm, directly or indirectly, any party or the property of the party to influence improperly the actions of a party;
- iv) "obstructive practice" is:

- Deliberately destroying, falsifying, altering, or concealing of evidence material to the investigation or making false statements to investigators in order to materially impede investigation by Public Procurement Regulatory Authority (PPRA) or any other appropriate authority appointed by Government of Kenya into allegations of a corrupt, fraudulent, coercive, or collusive practice; and/or threatening, harassing, or intimidating any party to prevent it from disclosing its knowledge of matters relevant to the investigation or from pursuing the investigation; or
- acts intended to materially impede the exercise of the PPRA's or the appointed authority's inspection and audit rights provided for under paragraph 2.3 e. below.

b) Defines more specifically, in accordance with the above procurement Act provisions set forth for fraudulent and collusive practices as follows:

"fraudulent practice" includes a misrepresentation of fact in order to influence a procurement or disposal process or the exercise of a contract to the detriment of the procuring entity or the tenderer or the contractor, and includes collusive practices amongst tenderers prior to or after tender submission designed to establish tender prices at artificial non-competitive levels and to deprive the procuring entity of the benefits of free and open competition.

- c) Rejects a proposal for award¹ of a contract if PPRA determines that the firm or individual recommended for award, any of its personnel, or its agents, or its sub-consultants, sub-contractors, service providers, suppliers and/ or their employees, has, directly or indirectly, engaged in corrupt, fraudulent, collusive, coercive, or obstructive practices in competing for the contract in question;
- d) Pursuant to the Kenya's above stated Acts and Regulations, may recommend to appropriate authority(ies) for sanctioning and debarment of a firm or individual, as applicable under the Acts and Regulations;
- e) Requires that a clause be included in Tender documents and Request for Proposal documents requiring (i) Tenderers (applicants/proposers), Consultants, Contractors, and Suppliers, and their Sub-contractors, Sub-consultants, Service providers, Suppliers, Agents personnel, permit the PPRA or any other appropriate authority appointed by Government of Kenya to inspect² all accounts, records and other documents relating to the procurement process, selection and/or contract execution, and to have them audited by auditors appointed by the PPRA or any other appropriate authority appointed by Government of Kenya; and
- f) Pursuant to Section 62 of the above Act, requires Applicants/Tenderers to submit along with their Applications/Tenders/Proposals a "Self-Declaration Form" as included in the procurement document declaring that they and all parties involved in the procurement process and contract execution have not engaged/will not engage in any corrupt or fraudulent practices.

¹ For the avoidance of doubt, a party's eligibility to be awarded a contract shall include, without limitation, (i) applying for pre-qualification, expressing interest in a consultancy, and tendering, either directly or as a nominated sub-contractor, nominated consultant, nominated manufacturer or supplier, or nominated service provider, in respect of such contract, and (ii) entering into an addendum or amendment introducing a material modification to any existing contract.

² Inspections in this context usually are investigative (i.e., forensic) in nature. They involve fact-finding activities undertaken by the Investigating Authority or persons appointed by the Procuring Entity to address specific matters related to investigations/audits, such as evaluating the veracity of an allegation of possible Fraud and Corruption, through the appropriate mechanisms. Such activity includes but is not limited to: accessing and examining a firm's or individual's financial records and information, and making copies thereof as relevant; accessing and examining any other documents, data and information (whether in hard copy or electronic format) deemed relevant for the investigation/audit, and making copies thereof as relevant; interviewing staff and other relevant individuals; performing physical inspections and site visits; and obtaining third party verification of information.

FORM OF TENDER SECURITY-[Option 1–Demand Bank Guarantee]

Beneficiary: _____

Request for Tenders No:

Date: _____

TENDER GUARANTEE No.: _____

Guarantor: _____

1. We have been informed that _____ (here inafter called "the Applicant") has submitted or will submit to the Beneficiary its Tender (here inafter called" the Tender") for the execution of _____ under Request for Tenders No. ("the ITT").
2. Furthermore, we understand that, according to the Beneficiary's conditions, Tenders must be supported by a Tender guarantee.
3. At the request of the Applicant, we, as Guarantor, hereby irrevocably undertake to pay the Beneficiary any sum or sums not exceeding in total an amount of _____ (____) upon receipt by us of the Beneficiary's complying demand, supported by the Beneficiary's statement, whether in the demand itself or a separate signed document accompanying or identifying the demand, stating that either the Applicant:
 - (a) has withdrawn its Tender during the period of Tender validity set forth in the Applicant's Letter of Tender ("the Tender Validity Period"), or any extension thereto provided by the Applicant; or
 - b) having been notified of the acceptance of its Tender by the Beneficiary during the Tender Validity Period or any extension there to provided by the Applicant, (i) has failed to execute the contract agreement, or (ii) has failed to furnish the Performance.
4. This guarantee will expire: (a) if the Applicant is the successful Tenderer, upon our receipt of copies of the contract agreement signed by the Applicant and the Performance Security and, or (b) if the Applicant is not the successful Tenderer, upon the earlier of (i) our receipt of a copy of the Beneficiary's notification to the Applicant of the results of the Tendering process; or (ii) thirty days after the end of the Tender Validity Period.
5. Consequently, any demand for payment under this guarantee must be received by us at the office indicated above onor before that date.

[signature(s)]

FORMAT OF TENDER SECURITY [Option 2–Insurance Guarantee]

TENDER GUARANTEE No.: _____

1. Whereas [*Name of the tenderer*] (hereinafter called “the tenderer”) has submitted its tender dated [*Date of submission of tender*] for the [*Name and/or description of the tender*] (hereinafter called “the Tender”) for the execution of _____ under Request for Tenders No. _____ (“the ITT”).

2. **KNOW ALL PEOPLE** by these presents that **WE** of [**Name of Insurance Company**] having our registered office at (hereinafter called “the Guarantor”), are bound unto [*Name of Procuring Entity*] (hereinafter called “the Procuring Entity”) in the sum of (Currency and guarantee amount) for which payment well and truly to be made to the said Procuring Entity, the Guarantor binds itself, its successors and assigns, jointly and severally, firmly by these presents.

Sealed with the Common Seal of the said Guarantor this ____ day of _____ 20 __.

3. **NOW, THEREFORE, THE CONDITION OF THIS OBLIGATION** is such that if the Applicant:
- a) has withdrawn its Tender during the period of Tender validity set forth in the Principal's Letter of Tender (“the Tender Validity Period”), or any extension thereto provided by the Principal; or
 - b) having been notified of the acceptance of its Tender by the Procuring Entity during the Tender Validity Period or any extension thereto provided by the Principal; (i) failed to execute the Contract agreement; or (ii) has failed to furnish the Performance Security, in accordance with the Instructions to tenderers (“ITT”) of the Procuring Entity's Tendering document.

then the guarantee undertakes to immediately pay to the Procuring Entity up to the above amount upon receipt of the Procuring Entity's first written demand, without the Procuring Entity having to substantiate its demand, provided that in its demand the Procuring Entity shall state that the demand arises from the occurrence of any of the above events, specifying which event(s) has occurred.

4. This guarantee will expire: (a) if the Applicant is the successful Tenderer, upon our receipt of copies of the contract agreement signed by the Applicant and the Performance Security and, (b) if the Applicant is not the successful Tenderer, upon the earlier of (i) our receipt of a copy of the Beneficiary's notification to the Applicant of the results of the Tendering process; or (ii) twenty-eight days after the end of the Tender Validity Period.

5. Consequently, any demand for payment under this guarantee must be received by us at the office indicated above on or before that date.

[Date]

[Witness]

[Signature of the Guarantor]

[Seal]

FORM OF TENDER - SECURING DECLARATION

[The Bidder shall complete this Form in accordance with the instructions indicated]

Date: *[insert date (as day, month and year) of Tender Submission]*

Tender No.: *[insert number of tendering process]*

To: *[insert complete name of Purchaser]* I/We, the undersigned,

declare that:

1. I/We understand that, according to your conditions, bids must be supported by a Tender-Securing Declaration.
2. I/We accept that I/we will automatically be suspended from being eligible for tendering in any contract with the Purchaser for the period of time of *[insert number of months or years]* starting on *[insert date]*, if we are in breach of our obligation(s) under the bid conditions, because we—(a) have withdrawn our tender during the period of tender validity specified by us in the Tendering Data Sheet; or (b) having been notified of the acceptance of our Bid by the Purchaser during the period of bid validity, (i) fail or refuse to execute the Contract, if required, or (ii) fail or refuse to furnish the Performance Security, in accordance with the instructions to tenders.
3. I/We understand that this Tender Securing Declaration shall expire if we are not the successful Tenderer(s), upon the earlier of:
 - a) Our receipt of a copy of your notification of the name of the successful Tenderer; or
 - b) thirty days after the expiration of our Tender.
4. I/We understand that if I am /we are/ in a Joint Venture, the Tender Securing Declaration must be in the name of the Joint Venture that submits the bid, and the Joint Venture has not been legally constituted at the time of bidding, the Tender Securing Declaration shall be in the names of all future partners as named in the letter of intent.

Signed:..... Capacity/title (director or partner or sole proprietor, etc.)

Name:..... Duly authorized to sign the bid for and on behalf of: *[insert complete name of Tenderer]*

Dated on day of, *[Insert date of signing]* Seal or stamp

Appendix to Tender

Schedule of Currency requirements

Summary of currencies of the Tender for _____ *[insert name of Section of the Works]*

<i>Name of currency</i>	<i>Amounts payable</i>
Local currency: _____	
Foreign currency #1: _____	
Foreign currency #2: _____	
Foreign currency #3: _____	
Provisional sums expressed in local currency	<i>[To be entered by the Procuring Entity]</i>

PART II - WORKS REQUIREMENTS

1. SCHEDULE OF RATES AND PRICES

General Information

The Price is divided into separate Schedules for each as follows:

1. Schedule No.1 – Preliminaries
2. Schedule No. 2 – Reinforced Concrete Cable Trench and 150mm PVC Ducts for Road Crossing
3. Schedule No. 3 – Supply and Installation of 18m Concrete Poles with Reinforced Concrete Pole Socket Mounting
4. Schedule No. 4 – Design Services for ocean channel crossing Steel Pylons, RC Foundations, and RC Cable Trench
5. Schedule No. 5 – Ocean Channel Crossing Steel Pylon Tower
6. Schedule No. 6 – Miscellaneous Items OCEAN CHANNEL CROSSING Steel Pylon Towers (*not to be included in the grand summary*)
7. Schedule No. 7 – Grand Summary

PREAMBLE TO THE PRICE SCHEDULES

SCOPE OF WORK

Design, Supply and Installation of 2No. Tension towers and 4No. Suspension towers, and 3-member concrete poles on both the mainland and the island

The tasks involve: -

- a) **Conduct thorough design, supply and installation of (including but not limited to survey and pegging of) 2No. Tension towers and 4No. suspension towers, and 3-member concrete poles on both the mainland and the island, String 223 sqmm Aluminium Conductor Composite Core (ACCC) across the Channel, design, supply, lay and terminate 1.6 kM underground MV cables complete with its accessories**
- b) **The double circuit line shall be strung across the Indian Ocean Channel and terminated on the 3- member concrete poles on both the Manda Island and Chosen part on the mainland with all the necessary structural support to withstand strong winds, adverse weather conditions in the coastal areas and complete with 48 core Optical Ground Wire (OPGW)**

General information

1. The bidder shall examine the scope of works in this section in close connection with the other documents and particulars forming the bids.

Special attention shall be paid to General specifications and particular technical specifications, in which the general technical requirements are specified. The drawings enclosed herein are for bidding purposes only.

2. If the specifications and/or drawings do not contain particulars of materials or goods which are necessary for the proper and safe completion, operation and maintenance of the equipment in question, all such materials shall be deemed to be included in the supply.
3. In the event of any conflict between the drawings and the specifications, the latter shall prevail.
4. Should the bidder find discrepancies in or omissions from these specifications or from the other documents, or should he be unclear or uncertain as to their meaning, they shall seek clarification in accordance with the Instructions to Bidders in the bidding documents prior to submitting their bid. Such action shall, however, in no case be considered as a cause for altering the closing date.
5. The scope of work for equipment shall cover engineering design, equipment and/or device coordination design, manufacture, testing before shipment and packing sea worthy or otherwise as required, delivering DDP, of all equipment as specified in the documents, pre-commissioning tests and commissioning of the facilities.
6. The quantities indicated in this tender document are approximate and may vary from the final quantities to be supplied. The final quantities shall be as identified after detailed design and the prices quoted shall apply on a per unit basis.
7. The Schedules do not generally give a full description of the plant and equipment to be supplied and the services to be performed under each item. Bidders shall be deemed to have read the Technical Specifications and other sections of the bidding documents and reviewed the Drawings to ascertain the full scope of the requirements included in each item prior to filling in the rates and prices. The entered rates and prices shall be deemed to include for the full scope as aforesaid, including overheads and profit.
8. If bidders are unclear or uncertain as to the scope of any item, they shall seek clarification in accordance with the Instructions to Bidders in the bidding documents prior to submitting their bid.
9. If the specifications and/or drawings do not contain particulars of materials or goods which are necessary for the proper and safe completion, operation and maintenance of the equipment in the scope of works and the bidder has not requested for any amendment, all such materials shall then be deemed to be included in the supply.
10. In the event of any conflict between the drawings and the technical specifications, the latter shall prevail and the project manager shall be notified of the discrepancy for reconciliation and guidance.
11. Should the bidder find discrepancies in or omissions from these specifications or from the other documents, or should he be unclear or uncertain as to their meaning, they shall seek clarification in accordance with the Instructions to Bidders in the bidding documents prior to submitting their bid. Such action shall, however, in no case be considered as a cause for altering the closing date.

12. The scope of work for equipment shall also cover engineering design, equipment and/or device coordination design, manufacture, testing before shipment and packing sea worthy or otherwise as required, delivering DDP (including transportation, Local Taxes, duties and levies) of all equipment as specified in the documents, pre-commissioning tests and commissioning of the facilities.
13. The contractor shall provide at his own cost where directed along the line for geotechnical investigations and reporting by an approved Geotechnical Engineer.
14. All materials and workmanship used in the execution of the work shall be of the best quality and description unless otherwise stated. The Contractor shall order all materials to be obtained immediately after the Contract is signed to ensure that they are on site when required for use in the works. The Bills of Quantities shall not be used for the purpose of ordering materials.
15. **MANDATORY SITE VISIT** :The Contractor is recommended to visit the site. He shall be deemed to have acquainted himself therewith as to its nature, position, means of access or any other matter which, may affect his tender. No claim arising from his failure to comply with this recommendation will be considered.
16. Means of access to the Site shall be agreed with the PROJECT MANAGER prior to commencement of the work and Contractor must allow for building any necessary temporary access roads for the transport of the materials, plant and workmen as may be required for the complete execution of the works including the provision of temporary culverts, crossings, bridges, or any other means of gaining access to the Site. Upon completion of the works, the Contractor shall remove such temporary access roads; temporary culverts, bridges, etc., and make good and reinstate all works and surfaces disturbed to the satisfaction of the PROJECT MANAGER
17. The works shall be executed under the direction and to the entire satisfaction in all respects of the PROJECT MANAGER who shall at all times during normal working hours have access to the works and to the yards and workshops of the Contractor and sub-Contractors or other places where work is being prepared for the contract.
18. The Contractor shall provide within two weeks of Possession of Site and in agreement with the PROJECT MANAGER a Progress Chart for the whole of the works including the works of Nominated Sub-Contractors; one copy to be handed to the PROJECT MANAGER and a further copy to be retained on Site. Progress to be recorded and chart to be amended as necessary as the work proceeds.
19. All materials for incorporation in the works must be stored on or adjacent to the site before payment is effected unless specifically exempted by the PROJECT MANAGER. This includes the materials of the Main Contractor, Nominated Sub- Contractors and Nominated Suppliers.

Pricing

20. The Price Schedules shall be based on unit prices, which shall be inclusive of all aspects of the works on a turnkey basis including engineering survey, design of equipment, structures and power lines, supply (includes transport of all materials and equipment necessary for completion of the works and no transport shall be measured separately), installation, testing and commissioning.

The prices quoted for each items in the price schedules per unit basis shall be inclusive of but not limited to:

- Topographical Survey (Drone) and preparation of drawings
- Design of the power line as stated in line with KPLC's specifications
- Design of the equipment in line with KPLC's specifications
- Design of structures in line with KPLC's specifications
- Procurement and Supply of all the materials necessary for execution of the project to completion
- Factory visits by the employer's representatives during equipment manufacture
- Transportation, storage and handling of the materials including clearing at the port of entry
- Construction of the power lines, structures and installation of the equipment including:
 - i) Construction and erection of 11KV overhead line with Optical ground wire (OPGW)
 - ii) Construction and erection of steel towers as necessary
 - iii) Construction and erection of associated switchgear
 - iv) Testing and Commissioning of completed schemes including the OPGW

The major items listed under this shall require factory acceptance tests to be witnessed by three (3) representatives from the Client (REREC and staff nominated from the sagas) as a minimum:

- OPGW
- 11kV underground HT Cables
- Steel pylon tower (members and assembly)
- ACCC conductor
- Concrete poles

The costs associated to carrying out the above FATs shall be borne by the Contractor. This shall include but not limited to: -

- I. Return flight ticket on economy class for nominated employer representatives above.
- II. Per Diem at the approved REREC Rates for the travelling Employees.
- III. Visa application and processing fee and Local transport expense at the manufacturer's country.

The contractor shall issue a 45day notification prior to commencement of the FAT. All FAT related documentation including Quality control documents, design documents, test record sheets, test procedures shall be approved before offering equipment for FAT. The duration of each FAT shall be discussed and agreed by REREC and the Project Manager. This shall be reasonable enough to allow for conclusive testing of the equipment.

2. PRICE SCHEDULES

Schedule No. 1 - Preliminaries

ITEM	DESCRIPTION	AMOUNT
	PRICING OF ITEMS OF PRELIMINARIES AND PREAMBLES	
	Prices will be inserted against items of Preliminaries in the Contractor's priced Bills of Quantities and Specification.	
	<p>The Contractor shall be deemed to have included in his prices or rates for the various items in the Bills of Quantities or Specification for all costs involved in complying with all the requirements for the proper execution of the whole of the works in the Contract.</p> <p>ABBREVIATIONS TO UNIT OF MEASURE:</p> <ul style="list-style-type: none"> i) LM – Linear Metre ii) SM – Square Metre iii) CM- Cubic Metre iv) LS – Lump Sum v) KM – Kilometre 	
1	SIGNBOARD	
	Allow for providing, erecting, maintaining throughout the course of the Contract and afterwards clearing away a signboard as designed, specified and approved by the Project Manager.	
2	EXISTING SERVICES	
	Prior to the commencement of any work, the Contractor is to ascertain from the relevant authority the exact position, depth and level of all existing services in the area and he/she shall make whatever provisions may be required by the authorities concerned	
3	STORAGE OF MATERIALS	
	The Contractor shall provide at his own risk and cost where directed on the site weather proof lock-up sheds and make good damaged or disturbed surfaces upon completion to the satisfaction of the PROJECT MANAGER. Nominated Sub- Contractors are to be made liable for the cost of any storage accommodation provided especially for their use.	
4	SAMPLES	
	<p>The Contractor shall furnish at his own cost any samples of materials or workmanship including concrete test cubes required for the works that may be called for by the PROJECT MANAGER for his approval until such samples are approved by the PROJECT MANAGER and the PROJECT MANAGER, may reject any materials or workmanship not in his opinion to be up to approved samples. The PROJECT MANAGER shall arrange for the testing of such materials as he may at his discretion deem desirable, but the testing shall be made at the expense of the Contractor and not at the expense of the PROJECT MANAGER. The Contractor shall pay for the testing in accordance with the current scale of testing charges laid down by the Ministry of Lands, Public Works, Housing and Urban Development (State Department of Public Works).</p> <p>The procedure for submitting samples of materials for testing and the method of marking for identification shall be as laid down by the</p>	

	PROJECT MANAGER The Contractor shall allow in his tender for such samples and tests.	
5	GOVERNMENT ACTS REGARDING WORK, PEOPLE ETC.	
	<p>Allow for complying with all Government Acts, Orders and Regulations in connection with the employment of Labour and other matters related to the execution of the works. In particular the Contractor's attention is drawn to the provisions of the Factory Act 1950 and his tender must include for all costs arising or resulting from compliance with any Act, Order or Regulation relating to Insurances, pensions and holidays for workpeople or so the safety, health and welfare of the workpeople.</p> <p>The Contractor must make himself fully acquainted with current Acts including Police Regulations regarding the movement, housing, security and control of and Regulations, labour, labour camps, passes for transport, etc. It is most important that the Contractor, before tendering, shall obtain from the relevant Authority the fullest information regarding all such regulations and/or restrictions which may affect the organisation of the works, supply and control of labour, etc., and allow accordingly in his tender. No claim in respect of want of knowledge in this connection will be entertained.</p>	
6	SECURITY OF WORKS ETC.	
	The Contractor shall be entirely responsible for the security of all the works stores, materials, plant, personnel, etc., both his own and sub-contractors' and must provide all necessary watching, lighting and other precautions as necessary to ensure security against theft, loss or damage and the protection of the public.	
7	PUBLIC AND PRIVATE ROADS.	
	Maintain as required throughout the execution of the works and make good any damage to public or private roads arising from or consequent upon the execution of the works to the satisfaction of the local and other competent authority and the PROJECT MANAGER	
8	EXISTING PROPERTY.	
	The Contractor shall take every precaution to avoid damage to all existing property including roads, cables, drains and other services and he will be held responsible for and shall make good all such damage arising from the execution of this contract at his own expense to the satisfaction of the PROJECT MANAGER	
10	WATER AND ELECTRICITY SUPPLY FOR THE WORKS	
	The Contractor shall provide at his own risk and cost all necessary water, electric light and power required for use in the works. The Contractor must make his own arrangements for connection to the nearest suitable water main and for metering the water used. He must also provide temporary tanks and meters as required at his own cost and clear away when no longer required and make good on completion to the entire satisfaction of the PROJECT MANAGER. The Contractor shall pay all charges in connection herewith. No guarantee is given or implied that sufficient water will be available from mains and the Contractor must make his own arrangements for augmenting this supply at his own cost. Nominated Sub-contractors are to be made liable for the cost of any water or electric current used and for any installation provided especially for their own use.	
11	SANITATION OF THE WORKS	
	The Sanitation of the works shall be arranged and maintained by the Contractor to the satisfaction of the Government and/or Local Authorities, Labour Department and the PROJECT MANAGER	

12	PROTECTIVE CLOTHING	
	<p>The Contractor shall provide all protective or any other special clothing or equipment for his employees that may be necessary. This shall include, inter-alia, safety helmets, gloves, goggles, earmuffs, gumboots, overalls, etc., according to the type of work.</p> <p>The Contractor shall ensure that safety helmets are worn by all staff at all times.</p>	
13	INSURANCE	
	<p>The Contractor shall insure as required in Conditions No 30 of the Conditions of Contract. No payment on account of the work executed will be made to the Contractor until he has satisfied the PROJECT MANAGER either by production of an Insurance Policy or and Insurance Certificate that the provision of the foregoing Insurance Clauses have been complied with in all respects. Thereafter the PROJECT MANAGER shall from time to time ascertain that premiums are duly paid up by the Contractor who shall if called upon to do so, produce the receipted premium renewals for the PROJECT MANAGER's inspection.</p>	
14	ALTERATIONS TO BILLS, PRICING, ETC.	
	<p>Any unauthorised alteration or qualification made to the text of the Bills of Quantities may cause the Tender to be disqualified and will in any case be ignored. The Contractor shall be deemed to have made allowance in his prices generally to cover any items against which no price has been inserted in the priced Bills of Quantities. All items of measured work shall be priced in detail and the Tenders Sums to cover trades or groups of work must be broken down to show the price of containing Lump each item before they will be accepted.</p>	
15	PROTECTION OF THE WORKS.	
	<p>Provide protection of the whole of the works contained in the Bills of Quantities, including casing, casing up, covering or such other means as may be necessary to avoid damage to the satisfaction of the PROJECT MANAGER and remove such protection when no longer required and make good any damage which may nevertheless have been done at completion free of cost to the Government.</p>	
16	CONTRACTOR'S SUPERINTENDENCE/SITE AGENT	
	<p>The Contractor shall constantly keep on the works a literate English speaking Agent or Representative, competent and experienced in the kind of work involved who shall give his whole experience in the kind of work involved and shall give his whole time to the superintendence of the works. Such Agent or Representative shall receive on behalf of the Contractor all directions and instructions from the Project Manager and such directions shall be deemed to have been given to the Contractor in accordance with the Conditions of Contract.</p>	
	Total to Schedule 7 (Grand Summary)	

Schedule No. 2 - Reinforced Concrete Cable Trench and 150mm PVC Ducts for Road Crossing

RC CABLE TRENCH & ROAD CROSSING DUCTS					
Item No.	Description	Unit	Quantity	Unit Rate (Kshs)	Total Cost (Kshs.)
2.0 Bush Clearing, Site Preparation and Access Road					
2.0.1	Bush clearing and grubbing of the site, including removal of debris	SM	1600		
2.0.2	Setting out of trench alignment	LM	1600		
2.0.3	1.2 KMS Access Road	LM	1200		
2.1 Excavation and Earthworks					
2.1.1	Excavation for cable trench (900mm width 1200mm depth) in soil	CM	1728		
2.1.2	Additional excavation for trench foundations (300mm depth)	CM	-		
2.1.3	Disposal of excavated material off-site or stockpile	CM	1728		
2.2 Sub-base and Foundations					
2.2.1	Compaction of trench base with mechanical roller	SM	1800		
2.2.2	Laying of granular sub-base material (100 mm thickness)	CM	180		
2.2.3	Concrete blinding layer (75 mm thick) at trench base	CM	135		
2.3 Formwork and Reinforcement					
2.3.1	Formwork for trench sidewalls (18 mm thick marine board or steel)	SM	3840		
2.3.2	Formwork for trench base	SM	480		
2.3.3	Supply and installation of wall reinforcement bars (10 & 12 mm diameter)	SM	3840		
2.3.4	Supply and installation of base reinforcement (10 & 12 mm diameter)	SM	1440		
2.4 Concrete Works					
2.4.1	Casting reinforced concrete for trench base (150 mm thick)	CM	216		
2.4.2	Casting reinforced concrete for trench walls (150 mm thick)	CM	576		
2.4.3	Vibrating and finishing of concrete surfaces	SM	5280		
2.4.4	Curing of concrete (28 days)	SM	5280		
2.5 Removable Concrete Covers					
2.5.1	Supply and installation of removable	SM	1440		

RC CABLE TRENCH & ROAD CROSSING DUCTS					
Item No.	Description	Unit	Quantity	Unit Rate (Kshs)	Total Cost (Kshs.)
	precast concrete covers				
2.5.2	Provision of steel lifting hooks for covers (2No. per cover)	Each	10666		
2.6 PVC Duct Installation (for Road Crossing)					
2.6.1	Supply of 150mm diameter Heavy Duty PVC ducts of 6m length	LM	1728		
2.6.2	Installation of 150mm diameter Heavy Duty PVC ducts arranged in 3 layers (3 ducts per layer, total 9 ducts)	LM	1728		
2.6.3	Duct bedding and surround with concrete (150mm layer above and below ducts, where required for protection under road)	CM	177		
2.6.4	Marker tape and warning signage for ducts	LM	1728		
2.7 Drainage and Cable Support Accessories					
2.7.1	Supply and installation of cable supports (cable racks/trays) at maximum 600 c/c	LM	1600		
2.7.2	Provision for trench drainage system (PVC pipes, gravel bed with sump pits)	LM	1600		
2.8 Backfilling and Finishing Works					
2.8.1	Backfilling of the trench with selected material (backfill soil must be tested for plasticity & other soil properties)	CM	1536		
2.8.2	Compaction of approved backfill material in layers of 300mm thick to 98% MDD	CM	1536		
2.9 Underground Cable and Miscellaneous Items					
2.9.1	Supply and install complete with accessories and termination kits 185 mm ² as a set of three 1/C, AL/XLPE/SWG/PVC underground 1 core per-phase 11 kV Cable	KM	1.6		
2.9.2	Site cleaning and demobilization	LS	1		
2.9.3	Safety measures and signage during construction	LS	1		
Total to Schedule 7 (Grand Summary)					

Schedule No. 3 - Supply and Installation of 18m Concrete Poles with Reinforced Concrete Pole Socket Mounting

18M CONCRETE POLES WITH RC SOCKET MOUNTING					
Item No.	Description	Unit	Quantity	Unit Rate (Kshs.)	Total Cost (Kshs.)
3.0 Site Preparation and Pegging					
3.0.1	Clearing and grubbing of site, including removal of debris	SM	64		
3.0.2	Setting out and pegging pole locations	Each	12		
3.1 Excavation for Pole Foundations					
3.1.1	Excavation for 18m concrete pole foundation (assumed 0.5m*0.5m*2.4m deep)	CM	7.2		
3.1.2	Disposal of surplus excavated material	CM	1.2		
3.2 Supply of 18m Concrete Poles					
3.2.1	Supply of 18m precast pre-stressed concrete poles	Each	12		
3.2.2	Transportation of poles to site	LS	1		
3.3 Pole Supply and Installation					
3.3.1	Lifting and installation of 18m concrete poles	Each	12		
3.4 Reinforcement for Concrete Socket Mounting					
3.4.1	Supply and installation of reinforcement steel bars (assumed 8 mm diameter) for concrete socket mounting	Tonne	1		
3.4.2	Installation of steel mesh reinforcement for socket base (A 142 BRC or equivalent)	SM	3.0		
3.5 Concrete Works for Pole Backfill					
3.5.1	Supply of concrete (M20) for pole socket mounting	CM	6.0		
3.5.2	Pouring and compacting concrete for socket mounting (up to 2.4m depth)	CM	6.0		
3.5.3	Curing of concrete (28 days)	SM	3.0		
3.6 Earthing and Grounding					
3.6.1	Installation of earthing and grounding materials (copper earth rod, earth cable & other accessories in concrete)	Each	4		
3.7 Miscellaneous Items					

18M CONCRETE POLES WITH RC SOCKET MOUNTING					
Item No.	Description	Unit	Quantity	Unit Rate (Kshs.)	Total Cost (Kshs.)
3.7.1	Site cleaning and demobilization	LS	1		
3.7.2	Safety measures and signage during construction	LS	2		
Total to Schedule 7 (Grand Summary)					

Schedule No. 4 - Design Services for ocean channel crossing Steel Pylons, RC Foundations, and RC Cable Trench

DESIGN SERVICES					
Item No.	Description	Unit	Quantity	Unit Rate (Kshs.)	Total Cost (Kshs.)
4.0 Preliminary Design Services					
4.0.1	Site survey and assessment for cable trench, steel pylon towers and 18m concrete pole location, Complete profile survey including preparation of profiles and drawings	LS	1		
4.0.2	Preliminary hydrological and geotechnical studies by Materials Testing Department, Ministry of Roads & Transport – State Department of Roads	LS	1		
4.0.3	Preliminary design steel pylon towers layout (<i>general arrangement, tower spotting outline & profile and topographic survey of tower location</i>)	LS	1		
4.0.4	Preliminary drawings for pylon details (<i>tower schedule and tree diagram loading scenarios</i>)	LS	1		
4.1 Detailed Design Services					
4.1.1	Structural design of steel pylons (<i>suspension pylons, tension pylons, elevation views, connection details for cross arm, insulator & grounding components</i>)	LS	1		
4.1.2	Structural design of RC foundations for pylons (<i>pylon foundations including depth, width, type of foundation – pad, pile, raft, reinforcement details, position of anchor bolts and base plate</i>)	LS	1		
4.1.3	Electrical design drawings (<i>conductor profile & sag-tension drawings, earthing layout, insulator & hardware drawings, clearance drawings</i>)	LS	1		
4.1.4	Fabrication drawings (<i>pylon components – legs, braces, cross arms, bolts & nuts,</i>	LS	1		

DESIGN SERVICES					
Item No.	Description	Unit	Quantity	Unit Rate (Kshs.)	Total Cost (Kshs.)
	<i>welding detail & galvanization instruction</i>)				
4.1.5	Design of reinforced concrete cable trench (<i>dimensions, reinforcement details, removable cover plate & conduit arrangement including drainage provisions</i>)	LS	1		
4.2 Preparation of Design Documentation					
4.2.1	Preparation of comprehensive design report (<i>structural design, electrical design, sag & tension, environmental impact, safety & compliance reports</i>)	LS	1		
4.3 Regulatory and Compliance Services					
4.3.1	Submission of design documents for regulatory approval	LS	1		
4.3.2	Coordination with environmental and regulatory authorities	LS	1		
4.4 Miscellaneous Design Services					
4.4.1	Additional design modifications or revisions (as required)	LS	1		
Total to Schedule 7 (Grand Summary)					

Schedule No. 5 - Ocean Channel Crossing Steel Pylon Towers

Ocean Channel Crossing STEEL PYLON TOWERS					
Item	Description	UOM	Total Quantity	Current Unit Price (VAT Inclusive)	Total Local Price (VAT Inclusive)
5.0	SETTING OUT and SOIL INVESTIGATION				
5.0.1	Setting out of the transmission line route, pegging of tower positions, preparation of diagonal profiles and probe testing at each tower.	LS	1		
5.0.2	Prices for comprehensive soil investigations and tests including all overheads and earth resistance	Per tower	6		

	data per location as Specified				
5.0.2.1	Machine boring of single bore hole up to a depth of 10 meters including all necessary drilling, sampling, laboratory testing of samples, the preparation of reports, including correlations with in-situ tests detailed in relevant sections of specifications and in line with recommendations for design of foundations: including all mobilization and demobilization costs and all transport of equipment between tower sites (SPT)	Per tower	6		
5.0.2.2	Sub-soil investigations at support locations by means of in-situ penetrometer, vane test or bearing test to determine class of foundation to be installed	Per tower	6		
Sub-total, Survey works and soil investigation, item 5.0.1 – 5.0.2					
5.1	BUSH CLEARING and ACCESS ROAD				
5.1.1	Complete clearing of trees, bush and anthills as per Specification, along the transmission line route	Route KM	3		
5.1.2	Establishment of required vehicle access track and maintenance	KM	2.2		

	road along the cleared line route				
Sub-total, Bush clearing and access road, item 5.1.1 – 5.1.2					
5.2	FOUNDATION WORKS				
<i>Complete foundation (including stub, cleats and setting) including installation of tower earthing</i>					
5.2.0	COMPLETE FOUNDATION WORKS FOR TYPE 11kV TENSION/SUSPENSION TOWERS				
5.2.1	Concrete pad and chimney for soil class C1, C2, C3, C4, C4W, C5 or C5W	Per tower	4		
5.2.2	Special pilling, raft, enlarged concrete pad and chimney C6	Per tower	2		
Sub-total, Foundation works, item 5.0.1 – 5.2.2					
5.3	TOWER ERECTION				
<i>Complete erection works in accordance with Specifications, handling, storage at site and distribution to individual tower sites</i>					
5.3.0.a	COMPLETE ERECTION WORKS FOR TENSION TOWERS				
5.3.1.a	Type Tension tower, basic	Per tower	4		
5.3.2.a	Type Tension complete basic tower + 3m body extension	Per tower	1		
5.3.3.a	Type Tension tower + 6m body extension	Per tower	1		
5.3.4.a	Type Tension tower + 1m Leg extension	Each	1		
5.3.5.a	Type Tension tower + 2m Leg extension	Each	1		
5.3.6.a	Type Tension tower + 3m Leg extension	Each	1		
5.3.0.b	COMPLETE ERECTION WORKS FOR SUSPENSION TOWERS				
5.3.1.b	Type Suspension	Per	2		

	tower, basic	tower			
5.3.2.b	Type Suspension complete basic tower + 3m body extension	Per tower	1		
5.3.3.b	Type Suspension tower + 6m body extension	Per tower	1		
5.3.4.b	Type Suspension tower + 1m Leg extension	Each	1		
5.3.5.b	Type Suspension tower + 2m Leg extension	Each	1		
5.3.6.b	Type Suspension tower + 3m Leg extension	Each	1		
5.4	TOWER TYPE TESTS				
Tower type test to destruction (Nil) and ultimate loading (Tension)					
5.4.1	Type Tension with 6m body extension and 4 x 3m leg extension. Tower type test to ultimate loading including supply, erection, loading, testing, dismantling and replacement of damaged members. (The bidder shall include the facilitation cost of 2 RREC Engineers, 1 KPLC Engineer and the Project Manager).	Each	1		
Sub-total, Tower erection, item 5.2.1 – 5.4.1					
5.5	INSTALLATION OF EARTHING				
<i>The prices shall include distribution to individual sites, excavation, installation of rods, coils and counterpoise cable, all necessary connection, backfill and all other works necessary for installation as per specifications and approved drawings.</i>					
5.5.1	Measurement of electrical footing resistance to earth at each tower site, including recording in	LS	1		

	an approved manner				
5.5.2	Installation of additional tower earthing set based on counterpoise and rods	LS	1		
5.5.3	Installation of additional tower earthing based on counterpoise coil	LS	1		
5.6	Installation of complete tower earthing based on radial counterpoise				
5.6.1	Laying at 500mm depth	LS	1		
5.6.2	Laying at 750mm depth	LS	1		
5.7	Installation of continuous or extended counterpoise				
5.7.1	Laying at 500mm depth	LS	1		
5.7.2	Laying at 750mm depth	LS	1		
Sub-total, Installation of earthing, item 5.5.1 – 5.7.2					
5.8	INSTALLATION OF CONDUCTORS AND EARTHWIRES				
<i>All costs for distribution from storage to individual tower sites and complete installation up to six member concrete poles according to the Specifications and approved drawings and plans of insulator string assemblies and fittings, conductors and earth wires to correct sags, vibration dampers and transpositions as required and temporary guarding and scaffolding at crossings shall be included in the quoted prices.</i>					
5.8.0	Supply and Installation of Conductors:				
5.8.1	Supply and installation/Stringing of Double 3 Phase Circuit, using conductor type Aluminium Conductor Composite Core (ACCC) 223 sq. mm, insulators, isolators, stay wires, stay blocks, fittings, including vibration dampers,	Route KM	1.7		

	and other necessary equipment.				
5.8.2	Factory inspection and test witnessing of Phase conductors	LS	1		
5.9	Supply and Installation of Earth Wires:				
5.9.1	Supply and installation of 1 overrunning optical ground wire 48 core OPGW	KM	4.0		
5.9.2	Supply and erection of 600mm diameter aerial warning spheres	Per set	24		
5.9.3	Supply and erection of obstruction lighting including solar panels and ancillaries per ICAO regulation	Per set	-		
5.9.4	Complete set of Phase Conductor (ACCC) down leads (including low duty insulator sets)	Per set	10		
5.9.5	Set of one single ACS earthing wire to the ground including all fittings	LS	1		
5.9.6	Factory inspection and test witnessing of OPGW	LS	1		
Sub-total, Supply and Installation of Conductors and Earth wires, item 5.8.1 – 5.9.6					
5.10	OPGW JOINT BOXES and ELECTRICAL TESTS				
5.10.1	Jointing box for OPGW/OPGW for use within transmission line including fixing, splicing and down lead clamps	Sets	4		
5.10.2	FAT for the insulators	LS	1		
Sub-total, OPGW Joint Boxes and Electrical Tests, item					

5.10.1 – 5.10.2					
5.11	TOOLS, SPARES AND OTHER MISCELLANEOUS WORKS				
5.11.1	11 kV earthing Harness Set	NO.	1		
5.11.2	11 kV live line tester	NO.	1		
5.11.3	Screening Tape	NO.	1		
5.11.4	Complete set of slings for lifting	NO.	1		
5.11.5	OPGW Splicing tool	NO.	1		
5.11.6	Supply of Snake Leg Shields (Gaiters) and Bee Protection Suit with gloves for use by REREC Supervising Engineers during project implementation	Pair	10		
5.11.7	Painting of towers in red and white bands in accordance with ICAO regulations	Per tower	6		
5.11.8	Provision of temporary backstays to accommodate temporary termination of conductors on tension tower.	Per tower	4		
5.11.9	Anti-climbing devices and climbing steps	Per tower	6		
5.11.10	Danger, number and helicopter patrol plates	Per tower	6		
Sub-total, Tools, Spares and Other Miscellaneous Works, item 5.11.1 – 5.11.10					
TOTAL to Schedule 7(Grand Summary)					

Schedule No. 6 - Miscellaneous Items OCEAN CHANNEL CROSSING Steel Pylon Towers (*not to be included in the grand summary*)

	ADDITIONAL SCHEDULE OF RATES					
6.0	OCEAN CHANNEL CROSSING STEEL PYLON TOWERS					
6.0.0	SETTING OUT and SOIL INVESTIGATION					
6.0.1	Extra item 1.2.1 for additional bore	Per bore	1			
6.0.2	Extra item 1.2.1 & 1.2.2 for additional depth	Per bore	1			
6.0.3	Extra item 1.2.1 & 1.2.2 for boring in rock	Per meter	1			
6.1	FOUNDATION WORKS					
<i>Complete foundation (including stub, cleats and setting) including installation of tower earthing</i>						
6.1.0	MISCELLANEOUS PRICES FOR FOUNDATION WORK.					
<i>Special foundation works including pile caps, beams and modification of normal foundation to adapt specified foundation classes to cater for particular soil conditions</i>						
6.1.1	Additional structural concrete (grade C30) including cost of formwork	CM	1			
6.1.2	Additional excavation including reinstatement	CM	1			
6.1.3	Additional steel reinforcing bars including supply, bending and placing	Tonne	1			
6.1.4	Solid rock excavation excluding Class 1 foundations (including reinstatement)	CM	1			
6.1.5	Imported backfill	CM	1			
6.1.6	Rip-rap stone work, 0.5m deep over tower base to protect against erosion	SM	1			
6.1.7	1m*1m*1m rock-filled gabion installed to protect foundations against erosion	LM	1			

6.2	TOWER ERECTION					
<i>Complete erection works in accordance with Specifications, handling, storage at site and distribution to individual tower sites</i>						
6.2.0	PRICES FOR MISCELLANEOUS STEEL WORK, PRICES FOR SPECIAL TOWERS, SPECIAL EXTENSIONS AND MODIFICATIONS					
6.2.1	Structural Mild Steel	Tonne	1			
6.2.2	Structural High Tensile Steel	Tonne	1			

Schedule No. 7. Grand Summary

Item	Description	Total Price <i>Incl. VAT</i> and other relevant taxes and levy (Indicate currency)
1	Total Schedule No. 1. Preliminaries	
2	Total Schedule No. 2. Reinforced Concrete Cable Trench and 150mm PVC Ducts for Road Crossing	
3	Total Schedule No. 3. Supply and Installation of 18m Concrete Poles with Reinforced Concrete Pole Socket Mounting	
4	Total Schedule No. 4. Design Services for OCEAN CHANNEL CROSSING Steel Pylons, RC Foundations, and RC Cable Trench	
5.	Total Schedule No. 5. OCEAN CHANNEL CROSSING Steel Pylon Towers	
GRAND TOTAL to BID Form (Amount to insert in the e-Procurement portal)		
Name of Bidder		

TERMS OF REFERENCE

PROJECT TITLE: MANDA ISLAND 11KV DOUBLE CIRCUIT POWER LINE OCEAN CHANNEL CROSSING & ASSOCIATED WORKS (RETENDER)

Job Description/Output	<ol style="list-style-type: none">1. Design, supply, delivery, and installation of 6 No. pylon towers for the 11kV double circuit power line OCEAN CHANNEL CROSSING from the mainland to Manda Island2. Design, supply, delivery, and installation of special anchored 3 No. 18m poles at each suspension tower tee-off point on the mainland and Manda Island.3. Supply, delivery, and installation of 1.6 km, 11 kV 3-phase, 1-core per phase HT underground power cable.4. Geotechnical soil investigations for the 6 No. tower locations by the Materials Testing Department-Ministry of Roads and Transport (State Department of Roads)
Location	Lamu West Constituency, Lamu County
Approximate to the near Geographical Coordinates	712452.51E, 9754860.48N (Arc 1960 UTM ZONE 37 S) 712299.59E, 9754066.81N (Arc 1960 UTMZONE 37 S)
Expected Project Duration	24 months

1. Background

The Rural Electrification and Renewable Energy Authority (RREC), is a state corporation established under section 43 of the Energy Act. 2019. The corporation's main mandate is to promote renewable energy and accelerate rural electrification throughout the country in order to provide electricity to all Kenyans as well as contribute towards sustainable socio-economic development of the country in the attainment of Vision 2030 and Big 4 Agenda. The specific functions of the corporation are articulated in section 43 of the Act.

In execution of projects to electrify the rural areas in Kenya, RREC is to construct both HT and LT lines to supply Manda Island (Lamu West Constituency, Lamu County). The HT line is to cross the ocean at Njia ya Ndovu to successfully evacuate power. The OCEAN CHANNEL CROSSING shall require 6 No. steel pylon towers, 6 No. special anchored 18m poles, 1.6km of underground cabling and geotechnical soil investigation for the 6 No. towers.

Towards this end, RREC is therefore seeking to recruit a Turnkey Contractor for the design, supply, delivery and installation of the 11kV double circuit power line OCEAN CHANNEL CROSSING and associated work. The contractor shall be expected to design, supply, deliver and install with conformity with the relevant laws, policies, technical standards, specifications, protocols, procedures and regulations and shall be required to demonstrate professional, technical and financial competency to undertake the works.

2. Objective

The objective of this project is to provide grid connection from Mokowe Mainland to Manda Island via steel pylon towers, special anchored concrete poles and underground cable. This shall connect over 1200 residential customers, Manda airport and businesses to reliable power. The project shall be funded by the Government of Kenya.

3. Scope of Work

A. CIVIL AND STRUCTURAL WORKS.

i. Topographical Survey and Geotechnical Investigation

Detailed topographical survey including route alignment (Use of Drone Technology is advisable), profiling, digital terrain model, tower structure spotting, optimization of tower structure locations, soil resistivity measurement & geotechnical soil investigation (including special foundation locations), identifying the underground utilities by ground penetration method, identifying utilities over the ground and detailed marking on topo sheet. Overlay of the surveyed features on Cadastral (Boundary) Data is Mandatory.

ii. **6 No. Steel Pylon Towers**

The Contractor will be responsible for the following tasks/activities:

1. **Carrying out a site reconnaissance visit** prior to bidding and designing for the works.
2. **Design and proto type testing** of the transmission line towers (as required).
3. Contractor shall **meet the cost of travel for FAT for 2No. REREC Engineers, 1KPLC Engineer and the Project Manager**. Accommodation and per diem cost shall be met by the contractor. The following major equipment shall be offered for inspection:
 - OPGW
 - 11kV underground HT 1-core cables, a set of three cables.
 - Steel pylon tower (members and assembly)
 - ACCC conductor
 - Concrete poles
4. **Fabrication and supply of all type of transmission line towers** as per Approved Contractors design/drawings including OCEAN CHANNEL CROSSING towers including fasteners, step bolts, hangers, D-shackles etc. (as per requirement).
5. **Supply of all types of tower accessories** like phase plate, circuit plate (where ever applicable), number plate, pole plate (where ever applicable), danger plate, anti-climbing device, bird guard, (where ever applicable)
6. **Supply of;**
 - a) Earth wire
 - b) Hardware Fittings and accessories for Conductor/*Earth wire/ UG cabling.
 - c) Conductor
 - d) Insulators (If required)
 - e) OPGW & associated fittings & accessories.
 - f) LPE EHV UG cable.
 - g) Fiber Optic cable.
 - h) Cable outdoor termination & Straight through joints.
 - i) Link Boxes.
 - j) Bonding cables.
 - k) GI structure to hold cable at open crossing locations
7. **Classification of foundations** for different type of towers and **Casting of Foundations** for tower/ pole structure footings as per Approved Contractor's foundation design/ drawing.
8. For **transmission lines, to promote mechanization and safe working conditions**, use of crane is being promoted. Erection of towers/ monopole structures by using crane (wherever feasible), tack welding of bolts and nuts including supply and application of zinc rich paint, fixing of insulator strings, stringing of conductors and earth wires/OPGW along with all necessary line accessories. However, where usage of crane is not possible, erection of towers has to be carried out by conventional method i.e. using Gin pole, Derrick, Centre mast etc. through usage of Power Operated Winch Machines. No tractor shall be allowed for tower structure erection
9. **Import and Transport** steel pylon towers of various heights to site.
10. **Customs clearance, warehousing and transport** of towers to the required locations.
11. **Make excavation on the site according to the approved foundation design** regardless to the soil characteristics of the site. Additional claims will not be entertained by REREC due to site specific soil characteristics.
12. **Construct civil foundation for the tower according to the approved foundation design**. Ready-mi concrete shall be provided for all the foundations. In case ready-mi concrete is not available at a specific site for any reason, Contractor shall justify the reason & seek official approval for supplying any other type of concrete.

13. **Any additional requirement** such as curing compound, epoxy painted reinforcement steel, etc. shall be provided according to site specific condition for the foundation in case requested.
14. **Supply & Installation of tower structure earthing.** Provide grounding ring around the tower foundation which consists of a pair of 25mm x 3mm copper strips interconnected to each other at each corner & enough number of earthing rods shall be installed in order to provide a maximum earthing resistance of 3Ω for the Steel Pylon Tower. (Ma 10Ω for passive repeater towers.)
15. **Top 300mm HT copper strip** shall be embedded in concrete to prevent any theft of copper strip. Contractor should submit the drawing for approval. All grounding connections under the ground shall be **Cad Weld welding connections or C Clamp crimped using hydraulic jack** rather than mechanical joints.
16. **Backfill the foundation compacting by layers of ma 300mm with proper tools & machinery.** Contractor shall seek approval from REREC in order to utilize the existing excavation material for backfilling. Imported fill material shall be utilized if the existing excavation material is not approved engineer during steel inspection.
17. **Grounding system will consist of a lightning arrestor** at the top of the steel pylon tower, a down conductor which is directly connected to the grounding ring, grounding ring and earth pit. The down conductor shall run on one leg of the tower till grounding ring and all legs shall be connected to the grounding ring via 25mm 3mm copper strips.
18. **Painting the steel pylon towers** according to specifications & rules and regulations of the related authorities such as Kenya Civil Aviation Authority.
19. **Supply and install aircraft warning light system including aircraft warning spheres** according to the specifications & rules and regulations of the related authorities such as Kenya Civil Aviation Authority.
20. **Testing and commissioning** of the erected transmission lines and UG cables.
21. **Other items not specifically mentioned** in this Specification but are required for the successful commissioning of the transmission line through UG cabling, unless specifically excluded in the Specification.
22. **The installation/stringing of OPGW cable optic fiber cable** along with associated fittings & accessories shall be carried out by the contractor. The scope of installation/stringing shall include splicing, termination, testing, demonstration for acceptance & commissioning as well as documentation. Splicing is preferred to be carried out at Tension towers locations. However, it shall be permitted at Suspension Tower locations also as required due to site conditions. The installation/stringing and splicing shall be carried out as per manufacturer guidelines
23. **Level the area for excavation of the tower foundation** for the sites that does not require access road.
24. **Provide implementation plan (schedule)** for each tower and progress committed to the same.

Special Requirement of Works:

1. Supply of materials required for construction / diversion works shall be ensured within stipulated time as per the program from the date of site handover. BOQ's, Structural drawings, Shop drawings of transmission line tower shall be supplied by the Contractor. The Contractor shall be fully responsible for supply and services as per Technical Specifications attached in bid.
2. Use of tractor for final sagging shall not be permitted. The Contractor shall use power operated hydraulic/ motorized winch machines or and Tension puller. At least 2 power winch machines shall be deployed at the site.
3. Testing and commissioning of the erected transmission lines: The Contractor is liable to conduct Tower Footing Resistance (TFR) measurement of each location, accordingly the TFR testing kit (shall be taken back by the contractor once the measurement work is completed) shall be arranged by the contractor without any additional cost to REREC. If any fault observed the same shall be attended by contractor during defect liability period.

4. The scope of works includes stringing of conductor laying of EHV UG cables, earth wire & or OPGW laying of OPTIC fiber cable, erection/removal of hardware fittings, insulators, conductor, earth wire & or OPGW EHV UG cables, OPTIC fiber cable accessories, etc. and erection of towers of 11kV line. Loading, transportation & unloading of transmission line materials from the designated store to the site suitably so that the damage can be prevented.
5. The Contractor shall be responsible to secure compliance with all County & National Government laws as well as rules, regulations, Bye-laws and other of the local authorities and statutory bodies as may be in force from time to time as applicable. REREC shall also be responsible for giving the required notice to any statutory or local bodies as required by law and obtain all requisite license / permission as applicable to the agency for carrying out the work envisaged in the contract.
6. The responsibilities of acquiring Right of Way (ROW) for transmission line (tower foundation, tower erection & stringing of conductors etc.) corridor lies with REREC. Whereas, the Contractor shall be responsible for securing, for getting clearances from Kenya Ports Authority, Kenya Forest Service and Kenya Civil Aviation Authority. All statutory fees for getting clearance shall be paid against documentary evidence.
7. It is the responsibility of the Contractor to strictly adhere the procedure as required for obtaining clearances from the Kenya Ports Authority, Kenya Forest Service, Kenya Civil Aviation Authority and other Govt./Statutory Bodies.

iii. **1.6 km Underground 1-core cables (a set of three).**

1. Excavation of Trenches

The trench will be dug vertically to a minimum depth of 1200mm or more as required.

All precautions must be made so as not to cover any services e.g. fire hydrants with soil that may be encountered in the path of the trench. The cable shall at all times run under any services encountered and well protected at these crossings.

During construction on public roads passage and access of motorists and pedestrians to commercial areas must be maintained. All safety measures must be put in place.

In order to reduce the cost of reinstatement on roads and pavements the digging shall be done at intervals of 2-3 m and a gallery or tunnel dug underneath. All road crossings shall be through micro-tunneling and as approved by highway authorities.

The bottom of the trench must be made of firm material in order to prevent collapse of the base that may subject the cable to mechanical stress.

When several cables of different voltages are laid in the same trench they will be placed at different depths. The cables of the higher voltage will be placed deepest.

2. Concrete Works

Cable trenches and pre-cast removable RC covers (with lifting arrangement) shall be constructed using RC of M25 Grade.

The cable trenches shall be designed for the following loads:

- Dead load of 155 kg/ m length of cable support plus 75 kg on one tier at the end.
- Triangular earth pressure plus uniform surcharge pressure of 2 ton/m²
- Cable trench covers shall be designed for; self-weight of top slab plus concentrated load of 200 kg at centre of span on each panel and a surcharge load of 2 ton/m².

Trenches shall be gravity drained. Necessary sumps be constructed. Cable trenches shall not be used as storm water drains. The top of trenches shall be kept at least 250 mm above the finished ground level. The top of cable trench shall be such that the surface rain water does not enter the trench.

All metal parts inside the trench shall be connected to the earthing system.

A clear (vertical) space of at least 300 mm shall be available for each tier in cable trench. From trench bed to lowest tier, a minimum clearance of 200 mm shall be available, for trenches having more than one tier, the spacing between stands shall be 400mm. The trench bed shall have a slope of 1/500 along the run and 1/250 perpendicular to the run.

All construction joints of cable trenches i.e. between base slab to base slab and the junction of vertical wall to base slab, as well as from vertical wall to wall, and all expansion joints shall be provided with approved quality PVC water stops of approximately 230 x 5 mm size for those sections where the ground water table is expected to rise above the junction of base slab and vertical wall of cable trenches.

Cable trenches shall be blocked at the ends if required with brick masonry in cement sand mortar 1:3 and plaster with 12mm thick 1:3 cement sand mortar. Cable tray supports(all galvanized structures) shall be designed and constructed to be a single complete fabrication or assembly such that every layer of the horizontal cable tray supports are fixed, either bolted or welded, to a vertical steel support that is embedded in the concrete wall of the cable trench. It shall not be permitted to embed a horizontal support beam directly into the wall of the trough in order to use the concrete wall as a means of load bearing.

Concrete trenches shall be provided with concrete covers of suitable load bearing strength. Where the cable trenches are run across or within 3 m of service roads, the trough covers shall be capable of bearing an accidental wheel load of 20 kN. All the cable trenches shall be RC type with mixing ratio 1:1:2 (M25) with 12-20 mm coarse aggregate, river sand and class 42.5N of Ordinary Portland Cement. The deformed reinforcement bars (ribbed type) should be high yield steel of strength 500MPa. Concrete spacer blocks minimum size of 75mm should be used. Blinding concrete shall be 75mm thick and M15 grade.

Water used for mixing concrete and mortar shall be clean, fresh water obtained from an approved source and free from harmful chemicals, oils, organic matter and other impurities. Normally potable water may be considered satisfactorily for mixing and curing concrete and masonry work.

If the cement is delivered in bags, the Contractor shall provide at his own cost perfectly waterproof and well-ventilated sheds having a floor of wood or concrete raised at least 150 mm above the ground. The sheds shall be large enough to store sufficient cement to ensure continuity of work. Each consignment of each type of cement shall be stacked separately therein. On delivery at site the cement shall at once be placed in these sheds and shall be used in the order in which it has been delivered.

All cement shall be used within 3 months of the date of manufacture. Fine and coarse aggregates shall be obtained from the same source and the Contractor shall ensure that material from the source is known to have a good service record over a long period of time. Aggregate shall be hard and dense and free from earth, clay, loam and soft, clayey, shale or decomposed stone, organic matter and other impurities.

As soon as possible after the Contract has been placed the Contractor shall submit a list giving details of the sources from which he proposes to obtain concrete and mortar materials. Only materials from approved sources shall be brought to site, but Project Manager will be prepared to extend his approval to other satisfactory sources of supply which may be proposed by the Contractor. Approval of a source of supply shall not imply acceptance of material found not to conform to this Specification

All bar reinforcement shall be hot rolled steel except where the use of cold worked steel is specified on the drawings or otherwise approved.

The bars shall be round and free from corrosion, cracks, surface flaws, laminations, rough, jagged and imperfect edges and other defects. The bar reinforcement shall be new, clean and of the lengths and diameters described on the Drawings and Schedules. Bars shall be transported and stored so that they remain clean, straight, undamaged and free from corrosion, rust or scale. Bars of different diameters shall be separately bundled.

All steel bars are to be accurately bent cold to the shapes and sizes indicated on the Drawings and Schedules unless otherwise approved. Re-bending of bars and bending in position in the works shall not generally be allowed. Spot or tack welding for positioning bars in heavily reinforced areas will only be allowed with the express permission of the Project Manager. Extension of lengths of reinforcement by welding will not be permitted. Welding will be approved only in low stress members, and lap welding will not be approved in any circumstances.

Before fixing in the works bars shall be seen to be free from pitting, mud, oil, paint, loose rust or scale or other adherents harmful to the bond or strength of the reinforcement. Bars shall be fixed rigidly and accurately in position in accordance with the working drawings, unless otherwise approved by the Project Manager.

Reinforcement at all intersections shall be securely tied together with 1.5 mm soft annealed tying wire the ends of which shall be cut and bent inwards. Cover to the reinforcement shall have sufficient spacers and chairs of precast concrete of approved design shall be provided to maintain the specified cover and position. No insertion of bars in previously placed concrete shall be permitted.

Projecting bars shall be adequately protected from displacement. The fixing of reinforcement in the works shall be approved by the Project Manager before concrete is placed. Measurement will be based on the calculated weights of steel actually used in tonne corrected to second place of decimal.

Form work and reinforcement shall be approved in writing by the Project Manager before concrete is placed. The forms shall be well wetted and all shavings, dirt and water that may have collected at the bottom shall be removed before concrete is placed.

Concrete shall be deposited in its final position without segregation, re-handling or flowing. As far as possible concrete shall be placed in the formwork by means approved by the Project Manager and shall not be dropped from a height or handled in a manner which may cause segregation. Any drop over 1.8m shall have to be approved by the Project Manager. Once the concrete is deposited in its final position, it shall not be disturbed. Care should be taken to avoid displacement of reinforcement or movement of formwork.

The placing of concrete shall be a continuous operation with no interruption in excess of 30 minutes between the placing of continuous portions of concrete. When fresh concrete is required to be placed on previously placed and hardened concrete, special care should be taken to clean the surface of all foreign matter. For securing a good bond and water tight joint, the receiving surface should be made rough and a rich mortar placed on it unless it has been poured just before. The mortar layer should be about 15 mm thick with cement and sand proportion as that of the mix in use, and have the same water-cement ratio as the concrete to be placed.

After the concrete has been placed it shall be thoroughly compacted by approved mechanical vibration to a maximum subsidence without segregation and thoroughly worked around reinforcement or other embedded fixtures into the correct form and shape. Vibrators must be operated by experienced men and over vibration shall not be permitted. Care should be taken to ensure that the inserts, fixtures, reinforcement and formwork are not displaced or disturbed during placing of concrete. No concrete shall be placed in open while it rains. If there is any sign of washing of cement and sand, the concrete shall be entirely removed immediately. Slabs, beams and similar structure shall be poured in one operation normally. In special circumstances with the approval of Project Manager these can be poured in horizontal layers not exceeding 500mm in depth. When poured in layers, it must be ensured that the under layer is not hardened. Bleeding of under layer if any shall be effectively removed.

Compaction is necessary for production of good concrete. After the concrete has been placed it shall be thoroughly compacted by approved mechanical vibrator to a maximum subsidence without segregation and thoroughly worked around reinforcement or other embedded fixtures into the correct form and shape. Vibrators must be operated by experienced men. Care should be taken to ensure that the inserts, fixtures, reinforcement and formwork are not displaced or disturbed during the vibration of the concrete. The Contractors shall provide standby vibrators. Vibration is commonly used method of compaction of concrete, the use of mechanical vibrators complying with BS EN 60745-2-12:2009 for compacting concrete is recommended.

For all practical purposes, the vibration can be considered to be sufficient when the air bubbles cease to appear and sufficient mortar appears to close the surface and facilitate easy finishing operations. The period of vibration required for a mix depends upon the workability of the mix.

In order to achieve proper and complete strength of the concrete, the loss of water from evaporation should be prevented. 80% to 85% of the strength is attained in the first 28 days and hence this 28-day strength is considered to be the criterion for the design and is called characteristic strength. The concrete after setting for 24 hours shall be cured by keeping the concrete wet continuously for a period of 10 days after laying.

The curing increases compressive strength, improves durability, impermeability and abrasion resistance. Failure to carry out satisfactory curing can lead to cracking in the concrete. This in turn can lead to salt attack of the reinforcement and consequential failure of the structure. If cracks occur in a structure which are severe enough to affect the structure, the Contractor shall cut out and replace the defective concrete at his own cost. The Contractor's attention is, therefore, drawn to this particular aspect of proper and adequate curing

Construction joints are a potential source of weakness and should be located and formed with care and their number is kept to a minimum. When the work is to be interrupted, the concrete shall be rebated at the joint to such shape and size as may be required by the Project Manager or as shown on the drawings. All vertical construction joints shall be made with water bars which are rigidly fixed and shall provide a positive barrier against movement of water through the joint. Great care shall be taken when placing concrete around water bars because the space is often congested. Concreting shall be carried out continuously up to construction

joints.

Expansion joints shall be as shown on the drawings or as specified in the schedules. Expansion joint filler boards conforming to BS 6093:1993 and sealing strips shall have minimum transverse joints. Joints shall be vertical and straight except where otherwise approved and concrete surfaces and faces shall be flush on both sides of the joint.

Separation joints shall be with standard water proof paper or with as alkathene sheets about 1 mm in thickness. Lap length and sealing of laps shall be to the satisfaction of the Project Manager.

Form work shall be kept in position fully supported, until the concrete has hardened and gained sufficient strength to carry itself and any loads likely to be imposed upon it. Stripping must be effected in such a manner and at such a time that no shock or other injury is caused to the concrete. The responsibility for safe removal rests with the Contractor but the Project Manager may delay the time of striking if he deems it necessary.

Minimum periods, in the absence of agreement to the contrary, between completion of concreting and removal of forms are given below but due regard must be paid to the method of curing and prevailing conditions during this period.

Removal of shuttering to sides of rafts, walls, beams and columns	2 days
Removal of shuttering to slabs, beams and arches (props left under)	6 days
Removal of props to slabs, beams and arches	16 days
Lifting of pre cast members	16 days

The load test on concrete, if desired by the Project Manager shall be carried as soon as possible after the expiry of 28 days from the time of placing of concrete as per BS EN 12390-3. The structure shall be subjected to a load equal to full dead load of the structure plus 1.25 times the imposed load for a period of 24 hours and then the imposed load shall be removed. The entire cost of load testing shall be borne by the contractor and if any portion of the structure found unacceptable under the relevant clause in BS EN 12390-3 the same shall be dismantled and replaced by a new structure as per specification at no extra cost to the Employer. If during dismantling any of the adjacent structure is damaged, the same shall be made good free of charge by the Contractor to the satisfaction of the Project Manager.

Class A1 surfaces shall be dense, fair, smooth, even, free from honeycombing, water and air holes and other blemishes, true to line and surface and free from board or panel marking. They shall be of uniform colour. Rendering of defective surfaces shall not be permitted, and, if ordered by the Project Manager, the Contractor shall at his own expense cut out to expose reinforcement and make good any unsatisfactory work. All areas so treated shall be rubbed down and kept moist for several days.

Form work shall be constructed from marine board or metal, lined as necessary for special finishes and designed with the quality and strength required to ensure rigidity throughout placing, ramming, vibration and setting of the concrete, without detrimental effect.

Form work shall be erected true to line, level and shapes required using a minimum of approved internal ties. Faces in contact with the concrete shall be true and free from defect, jointed to prevent loss of water or fines, in panels or units which permit easy handling, and designed to permit side forms to be struck independently of soffit shuttering. Ties or spaces remaining embedded shall have the minimum cover specified for reinforcement.

Wedges and clamps shall be kept tight during vibration operations. Before commencement or resumption of concreting, the interior of forms shall be cleaned and free of sawdust, shavings, dust, mud or other debris and openings shall be formed to facilitate this cleaning and inspection. The inside of the forms shall be treated with a coating of an approved substance to prevent adhesion. Care shall be taken to prevent this substance being in contact with the reinforcement.

A frame of hot dip galvanized angles of size 50505 mm having provision of MS chairs on the grouting side on to the walls of the trench preferably at two locations (top) of the frame (these chairs have to be welded with the rods of the wall for better rigidity). Fixing of the cable tray support stand (Frame) is to be fixed at a distance of 1 meter from one frame to the other.

The thickness of the RC wall of the trench shall be 150mm and thickness of the cable cover shall be 75mm. All the frames for fixing of cable trays shall be of hot dip galvanized. A running earth strip has to run all through the cable trench for proper earthing of the cable trays and stand (frame). The size of the earth strip is of 506mm G.I flats. Welding the GI flats to the frame to be carried out. Earthing strips to be welded with the running earth mat at 10m interval.

Admixtures in concrete shall confirm to BS EN 934. The water proofing cement additives shall confirm to BS EN 934 (2). Concrete Admixtures/Additives shall be approved by REREC.

3. Backfilling of Trenches

The back fill will be laid in layers of 150mm, which should be compressed and watered if necessary in order to make the soil sufficiently compact.

4. Pavement Reinstating

The pavement shall be reinstated back to the standard of the original pavement. New materials will generally be used in accordance with County regulations and/ or road authority.

5. Ducts

Road crossings when necessary will be done with ducts in the following manner:

- The cables will be installed in a level position and concreted where possible to provide mechanical protection throughout its length, they will have a depth of 1.2m.
- Future expansion will be catered for by providing several spare ducts depending on the location of the crossing.
- The cables should be adequately protected at all times.
- The road and railway crossings must be planned in full detail.
- The drainage of the trenches must be provided for during and after construction.

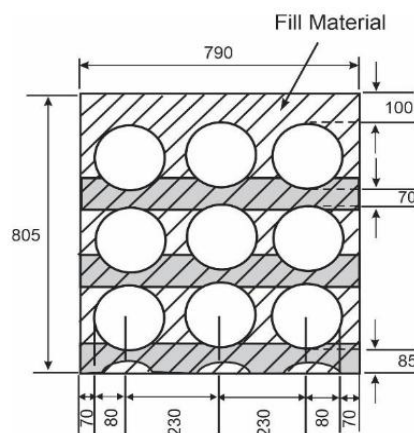

Figure 12: Nine-way bank of 150mm Conduits

Figure 1: *Parallel arrangement of 150mm conduit ducts*

In crossings with other normal underground services, a prudent distance will be maintained in view of future excavations, and when there is a possibility of service interference, as is the case of other electric cables, waste water sewers etc.

The ducts will be fabricated from PVC or concrete with a smooth interior surface and an interior diameter of not less than 2 times the diameter of the cable to be housed inside it, and in no case will this diameter be less than 150 mm.

The joints of ducts will be sealed with cement, in which case the bottom of the trench must be carefully levelled after setting down a layer of fine sand or red soil in order to permit continuous joints.

The ducts will be laid in such a manner that there is no abrasion between the insulation of the cable and the surface of the duct. In the cases of single core cables the cable will have to be anchored to prevent movement due to magnetic effects by concreting the ducts at the ends of the joints. This shall not apply to three core cables. When constructing a duct a length of wire will be left inside to facilitate the fitting of cleaning elements

as well as the cables themselves.

The cleaning will consist of passing inside a cylinder in order to remove concrete that will pass through the joints and later passing a broom or a rag to remove the residue.

6. Laying of ducts

Electrical cable ducts shall be laid and jointed in accordance with the Manufacturer's instructions.

7. Multiple runs to ducts

Electrical cable ducts in multiple runs whether encased in concrete or not, shall be laid at approved centres vertically and/or horizontally. The minimum concrete encasement where required is to be 150 mm. The final jointing of ducts in multiple runs shall be done in the trench, i.e. the duct shall be lowered and jointed singly not in groups, and duct joints shall be staggered by approximately half the duct length in alternate lines.

8. Cutting of ducts

The Contractor shall carry out any necessary cutting of pipe ducts according to the requirements of the work. Except where ducts enter the cable trench at an angle, they shall be cut at right angles to the length of the duct. The inside edges of cut ducts shall be thoroughly rounded off or so dressed before being placed in position so that there can be no possibility of damage to cables from the edges of the ducts. All electrical ducts entering draw pits shall be provided with suitable bell mouths.

9. Cleaning and testing of ducts

On completion of all electrical cable ducting, two mops of appropriate size connected one to each end of an iron mandrel shall be passed twice through each way to clean the conduit and to remove any foreign matter which may have entered. If any obstruction or other defect be discovered it shall be removed or rectified forthwith.

10. Sealing of electrical ducts

As soon as every duct or set of ducts has been proved and its draw wire material installed, the ends of the cut or its bell mouth where provided, shall be sealed to a depth of 5 mm with an appropriate sealer, and a single coat of bitumastic paint shall then be applied over the end of the ducts and the seal. The length of draw wire installed shall be such that at least one metre of draw wire extends from each end of each duct. After the ends of ducts have been sealed the free ends of draw wires shall be neatly coiled.

11. Foundations of Other Services

When there are structural supports for public transport, suspended telecommunication wires, street lighting, the electric cables will be laid at a distance of at least 500mm from the outer extremities of the supports or foundations of the structures. This minimum distance shall further be increased to 1.5m if the support or foundation is subject to continuous stress towards the curb sides.

If this separation cannot be maintained a resistant mechanical safety measure must be used throughout the length of the support and its foundation, extending to a length of 500mm, on both sides of outer extremes.

12. Crossing of Roads and Railroad Tracks

1. Public Roads

When crossing streets and roads cables must be laid at depths of at least 1.2m. The ducts must be durable and mechanically strong, and must have a minimum diameter of 150mm in order to permit the easy passage of the cables within the tubes. Conditions specified in the Electric Power Act must be observed at all times. Spare ducts must be provided where necessary.

2. Railroad tracks

Crossing railroad tracks must be done with reinforced concrete or heavy duty PVC reinforced by concrete 150mm thick surround laid perpendicular to the tracks at a minimum depth of 1.6 m. This depth must be measured from the bottom side of the track's crossbars. It is recommended that the crossing takes place at the narrower points of railroad areas. Conditions specified by municipalities and the Railroad companies shall take precedence.

13. 6No. 18 m Special Anchored Concrete Poles

Excavation

The pole socket will be dug vertically to a minimum depth of 2400mm as stipulated in KS 1933:2005. The bottom of the pole socket must be made of firm material in order to prevent collapse of the base that may subject the pole to mechanical stress.

Special Anchor

The excavated pole socket shall be filled with M20 concrete which shall be well compacted by vibration at 4000 cycles. The concrete shall be reinforced appropriately to withstand pull out force and torsional forces during stringing and tensioning.

The three pole sockets shall be connected so as to allow the structure to act monolithically.

The concrete shall be cure for 28 days.

Earthing is to be performed according to KS 04-503.

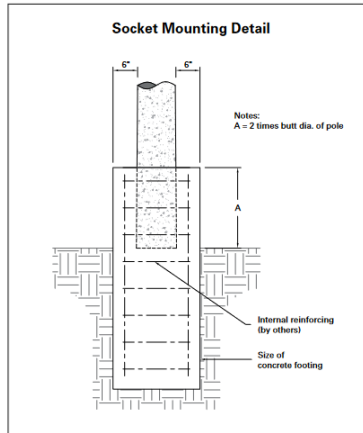

Figure 2: Pole Socket Mounting with Reinforced Concrete

14. Project Deliverables

1. Site geotechnical, hydrogeological and soil resistivity investigation reports as required.
2. Topographical survey including base line and control points as required.
3. Project proposals; delivery timelines, method statements, monthly/quarterly cash flow forecasting, risk & issue logs etc. approved by Employer.
4. Engineering reports for works undertaken and as required by Employer.
5. Signed Minutes of Meetings held.
6. Quality assurance tests and reports as per engineering standards and as required by Employer.
7. Schematic design drawings, calculations, specifications and design reports. The drawings to be in large-scale for buildings and constructions as required and other additional plans and specifications as may be deemed necessary by the Employer for the proper execution of the works. All drawings MUST be reviewed and approved by the Employer prior to implementation. 3 (three) copies CD/DVD in CAD and PDF format of 'as-built' drawings are to be collated and submitted at project closure.
8. Weekly and monthly reports of the activities undertaken; to include monthly/quarterly payment application for certified works.
9. Completed works/product; the technical, functional and project closure requirements must be satisfied.

15. Key Responsibilities

Contractor

1. Project Planning and Design Documentation

Detailed Engineering Design: Provide comprehensive design plans for the steel pylon towers, concrete poles, and cable trench. These should include structural analysis, load calculations, geotechnical reports, and environmental impact assessments.

Construction Method Statements: Detailed procedures for each phase of the construction, including mobilization, tower erection, concrete works, cable trenching, and cable laying. Address challenges such as offshore and onshore work and tidal conditions.

Health, Safety, and Environmental (HSE) Plan: Implement a robust HSE plan addressing risks associated with OCEAN CHANNEL CROSSINGS, heavy equipment, worker safety, and environmental protection. This should include hazard analysis, safety protocols, and waste management plans.

2. Material and Equipment

Material Specifications: Ensure the supply and use of high-quality materials, such as corrosion-resistant steel for pylons and marine-grade concrete for poles and trenches. Adhere to international standards (e.g., IEC, ASTM, and BS).

Logistics Plan: Outline the transportation plan for materials and equipment, especially for heavy machinery and oversized loads like steel pylons. Plan for sea and land transport routes and offloading strategies.

3. Construction

Foundation Works: Properly design and construct pylon foundations based on seabed or soil conditions. Use pile or caisson foundations offshore, and reinforced concrete foundations onshore.

Installation of Steel Pylons and Concrete Poles: Execute precise installation, ensuring that each structure meets design tolerances for height, alignment, and load-bearing capacity. Use cranes, barges, or helicopters where needed for offshore work.

Cable Trenching and Laying: Construct reinforced concrete cable trenches with accurate dimensions. Install electrical cables using cable reels, and ensure the use of armored or high-durability cables in marine environments.

Quality Assurance and Quality Control (QA/QC): Perform regular inspections and testing (e.g., foundation integrity, steel quality, and concrete strength tests). Develop a quality checklist for each deliverable.

4. Scheduling and Reporting

Detailed Project Schedule: Submit and maintain an up-to-date project schedule using tools like MS Project or Primavera. This schedule should show key milestones and timelines for engineering, procurement, and construction.

Progress Reports: Provide weekly or bi-weekly progress reports detailing the status of deliverables, completed works, any delays or risks, and mitigation measures.

Change Management: Document any variations or changes in scope with proper justifications and cost estimates. Ensure timely communication of changes to the Client.

5. Commissioning and Handover

Testing and Commissioning: Perform thorough testing of electrical systems, including insulation resistance, continuity tests, and live voltage tests once the cables are laid.

As-built Drawings and Documentation: Deliver final as-built drawings that reflect any modifications made during construction. Provide operation manuals, maintenance schedules, and warranties for installed equipment.

Training: Offer training sessions to Client's operation and maintenance personnel on handling the installed systems and troubleshooting.

Client (REREC)

1. Clear Scope Definition and Requirements

Detailed Scope of Work: Provide the Contractor with a clear and detailed Scope of Work (SOW) that outlines the project's technical and operational requirements, including specifications for the ocean-crossing power line and trench.

Technical Standards and Regulations: Set specific standards (e.g., voltage rating, load capacities, material specifications) and ensure the Contractor adheres to all local and international regulatory requirements.

Environmental and Permitting Requirements: Ensure that the Contractor has obtained necessary environmental approvals, marine permits, and utility clearances before starting construction.

2. Contract Management and Governance

Contractual Clarity: Ensure the contract documents are clear in terms of the deliverables, milestones, payment schedules, and penalties for delays or non-compliance.

Stakeholder Communication Plan: Set up a robust communication protocol between the Contractor, Client, and any third-party stakeholders, including regulatory authorities, local communities, and environmental agencies.

3. Project Oversight and Monitoring

Third-Party Inspection and Supervision: Engage independent inspectors to verify the quality of work and compliance with specifications at key construction stages. This ensures objectivity in QA/QC processes.

Regular Site Audits: Conduct regular site audits and inspections to monitor progress, safety practices, and compliance with environmental standards.

Progress Review Meetings: Hold regular progress review meetings with the Contractor to discuss project updates, risks, and opportunities for improvement.

4. Financial Oversight

Cost Monitoring: Use Earned Value Management (EVM) or similar cost control systems to track project expenditures against the budget. This helps in detecting cost overruns early.

Milestone-Based Payments: Structure payment schedules based on the achievement of pre-defined milestones (e.g., completion of tower foundations, tower erection, trench completion).

5. Risk Management and Contingency Planning

Risk Mitigation Plans: Collaborate with the Contractor to create a risk management plan that covers marine work challenges, weather disruptions, supply chain delays, and environmental risks.

Contingency Budget: Allocate a contingency budget to handle unforeseen issues such as environmental impacts, regulatory delays, or equipment failures.

6. Final Acceptance and Warranty

Final Inspection and Acceptance Testing: Ensure final inspections and acceptance tests are conducted to verify that all systems are functional, meet performance criteria, and are safe to operate.

Performance Warranty: Ensure the Contractor provides warranties covering performance, material defects, and workmanship. The Client should also enforce post-construction maintenance requirements.

16. Scheduling and Timelines

The construction of an ocean-crossing power line using steel pylon towers, concrete poles, and a reinforced concrete cable trench is a complex project that requires careful planning and scheduling. The total project duration is approximately **24 months**, followed by a **Defect Liability Period (DLP)** of **1 year**.

Key Milestones are as follows:

1. **Submission of a detailed work plan:** Month 1
2. **Topographical Survey, Design and Permits Complete:** Month 2
3. **Site Investigation and Geotechnical Report:** Month 3
4. **Submission of civil, structural and electro-mechanical designs:** Month 4
5. **Manufacture of Towers:** Month 8
6. **FAT of Towers:** Month 10
7. **Foundation Work Complete:** Month 12
8. **Shipment and delivery to site of Towers:** Month 14
9. **Towers and Poles Erected:** Month 18
10. **Cable Trenching Complete:** Month 20
11. **Cable Laying Complete:** Month 21
12. **Testing and Commissioning Complete:** Month 23
13. **Project Handover:** Month 24
14. **Defect Liability Period Ends:** Month 36

17. Payment Terms

Payment Schedule Based on Milestones as follows:

Milestone	Payment Percentage	Conditions
Advance Payment	10%	Against bank guarantee (Advance Payment Bond)
Completion of Topographical Survey & Geotechnical Reports	1%	Site investigation report approved
Submission of the firm design drawings	2%	Approved firm design drawings
Manufacture and FAT of Towers and 18M poles	3%	Proof of manufacture and FAT report
Foundation Completion for Towers/Poles	4%	Verified by Client
Shipment, delivery and completion of Tower and Pole Erection	25%	Physical verification of erected towers
Cable Trenching and Cable Laying Completion	15 %	Trenching work and cable installation verified
Commissioning and Testing	20%	Final inspection, testing, and commissioning report
Final Payment	10%	After submission of as-built documents and Client's final acceptance
Release of Retention Payment	10%	At the end of the Defect Liability Period

18. Performance Evaluation

1. Adherence to Project Schedule

Meeting key project milestones (e.g., foundation work, tower erection, cable laying, and testing) within the agreed timelines.

2. Quality of Workmanship

Adherence to technical specifications and design standards as per contract documents. The quality of materials used, and the execution of works (including concrete foundations, tower erection, and cable installation).

3. Cost Control and Budget Management

Maintaining project costs within the agreed budget. Justification and management of any cost overruns, including the Contractor's ability to provide detailed breakdowns for change orders or variations.

4. Safety Performance

Compliance with project-specific safety plans, risk assessments, and regulations. Implementation of safety measures, especially for high-risk tasks such as offshore pylon construction, heavy lifting, and high-voltage cable handling.

5. Environmental and Regulatory Compliance

Adherence to environmental regulations and the project's Environmental Impact Assessment (EIA) commitments. Compliance with national regulatory standards and permits, such as construction permits and electrical safety certifications.

6. Communication and Coordination

The Contractor's ability to maintain regular communication with the Client, project consultants, and other stakeholders. Submission of progress reports, project updates, and timely responses to requests for information (RFIs).

7. Management of Resources (Labor, Equipment, and Materials)

Proper allocation and utilization of skilled labor, construction equipment, and materials. Availability of key resources when required to meet project milestones.

8. Contractual and Legal Compliance

Compliance with all contract terms, including meeting insurance requirements, bond submissions, and adherence to dispute resolution mechanisms.

9. Defect Liability Period (DLP) Performance

The Contractor's responsiveness in addressing defects that arise during the Defect Liability Period (typically 1 year). Timely and quality resolution of issues flagged by the Client during DLP.

10. Client Satisfaction

Overall satisfaction of the Client with the Contractor's performance in terms of quality, safety, schedule, communication, and support. Feedback from periodic project meetings, final project review, and project close-out.

TECHNICAL REQUIREMENTS AND SPECIFICATIONS

1. SUPPLY AND INSTALL MATERIAL MANUAL

As soon as final support positions are approved, the Contractor shall provide the requisite copies of the A4 size Supply Install Material Manual (SIMM).

Each support position shall be represented by one of the manuals with the following information recorded:

- a. Provisional and final support numbers.
- b. Profile and record map reference drawing numbers.
- c. Span
- d. Wind span
- e. Weight Span
- f. Angle of deviation
- g. Support type, leg and body extensions and General Arrangement (G.A.) drawing reference numbers
- h. Foundation type and G.A. drawing reference number
- i. Earthing details and G.A. drawing reference number
- j. Insulator set details and G.A. drawing reference number
- k. Sag adjustment setting and linkage requirements – (where appropriate)
- l. Phase conductor jumper details including spacer and general arrangements drawing reference number – (where appropriate)
- m. Earth wire set details and G.A. drawing reference number
- n. Earth wire vibration damper G.A. drawing reference number
- o. Aircraft navigator (obstruction aids) drawing reference number – (where appropriate)
- p. Fibre optic junction boxes and cabling G.A. drawing reference number – (where appropriate)

In addition the following schedules shall be included:-

- i. Phase conductor and OPGW (ground wire) sags and tension (erection and final)
- ii. Suspension insulator sets off-sets
- iii. Location and spacing of all phase conductor spacers dampers – (where appropriate)
- iv. Location of all phase conductor and earth wire tension and non-tension joints
- v. Location and spacing of all aircraft warning spheres (where appropriate)
- vi. Location of all fibre optic joint boxes – (where appropriate)

The appropriate reference drawing numbers shall also be included. Preliminary copies of SIMMs shall be available prior to any site work commencing, together with materials summaries. This is Hold Point.

2. MAINTENANCE MANUAL

The Contractor shall provide at the specified period before the end of the construction period of the contract, a maintenance manual covering the following information:-

- a) Type, code numbers and description of all plant erected, together with names and addresses of manufacturers
- b) Methods of assembly of all fittings
- c) Method of replacing any part of the plant including the use of maintenance holes provided on the support access provisions and where appropriate the application of “live – line’ maintenance techniques.
- d) Recommendations of preventive maintenance including frequency of inspection.
- e) List of recommended maintenance equipment with a description of its use and limitations
- f) Type and application of temporary Earthing equipment.
- g) Personal safety equipment requirement and any risk assessment required.

The above information must be specified to this contract and entirely in the English language.

Drawings and diagrams shall be used where necessary to enable the Employer/Purchaser to properly maintain the whole of the works.

The manual shall be suitably bound within a hard cover and all materials used shall be reasonably hard wearing.

The manual shall be submitted to the Employer. This is Hold Point.

3. SAMPLES AND MODELS

If the nature of the works makes it desirable the Contractor/ supplier may be asked to submit or prepare for the Employer such samples, patterns and models as the Employer may reasonably require for the purpose of design approval at the expense of the Contractor/supplier.

4. PHOTOGRAPHS

The Contractor shall make all arrangements to provide progress photographs of all tests and such sections of the work in progress as directed by the Employer. Each photograph shall be of size 25cm x 20cm suitably entitled, in digital format. The photographs shall be the property of the Employer and no copies of the photographs shall be released without the authority of the Employer.

The Contractor will normally be required to provide every month at his own cost the specified number of sets of un-mounted progress photographs suitably inscribed of portions of the work in progress throughout the period of construction. Any variation to these quantities will only be with the permission of the Employer.

5. DAMAGES

5.1 General

The Contractor shall take all reasonable precautions to avoid damage to land, property, roads, crops, fields drains, fences walls, hedges, gates, trees and the like and shall ensure that the work is adequately supervised so that any damage is reduced to the minimum. Save as otherwise provided, the Contractor will be liable for all damage arising by or in consequence of the works except unavoidable damage to crops and shall pay compensation or make good at the option of the Employer.

5.2 Contractor's Responsibility

The Contractor's liability for loss or damage shall extend to any such loss or damage resulting from the employment of a Subcontractor. This does not relieve the Contractor of his liability for all actions of his Subcontractor.

5.3 Livestock

Adequate provision shall be made by the Contractor to prevent the straying of or injury to livestock during the execution of the work and until the permanent reinstatement of fences, wall, hedges, gates and the like is completed.

The Contractors shall be liable for any injury to or loss of livestock due to failure to comply with the above requirements.

6. GEOTECHNICAL INVESTIGATION

6.1 General

Geotechnical investigations shall be undertaken in accordance with the technical requirements detailed in the following clauses.

Where required by the Employer, the Contractor or his appointed geotechnical consultant shall undertake the specified slope stability analysis and design.

The Contractor shall give the Employer the requisite period of notice prior to commencing

the geotechnical investigation. This is a Hold Point.

6.2 Level 1

Level 1 geotechnical investigations shall be based on a visual-tactile examination or disturbed soil samples for the determination of both soil classification and strength.

6.3 Level 2

Level 2 geotechnical investigations shall be based on in-situ testing for the determination of the soil strength and visual tactile examination of disturbed samples for the determination of soil classification

6.4 Level 3

Level 3 geotechnical investigations shall be based on in-situ testing (as level 2) for the determination of the soil strength and the recovery of disturbed soil samples for the subsequent laboratory testing. Laboratory soil classification tests for non-cohesive soils shall be particle size distribution, moisture content and relative density, whilst those for cohesive soils shall be moisture content and Atterberg limits.

6.5 Level 4

Level 4 geotechnical investigations shall be based on a combination of in-situ testing (as level 2) and the recovery of disturbed/undisturbed soil samples for the subsequent laboratory testing.

6.6 Soil and Ground Water Samples

Where specified, soil and ground water samples shall be obtained for determination of the chemical content i.e. organic matter, sulphate, pH and chloride content.

6.7 Geotechnical Investigation Criteria

Geotechnical investigation shall be undertaken to the following criteria:

- a) Geotechnical investigation shall be undertaken as near as possible to the tower site. For test foundations the investigation shall be undertaken as near as possible to the test site, and shall take account of the theoretical failure surface of the foundation;
- b) Time lapses between the investigation and foundation installation shall take into account any noticeable effect on the geotechnical properties due to rainfall or seasonal variations in the groundwater level;
- c) Depth of investigation shall be:
 - i. For trial pits 2m; or
 - ii. the foundation depth plus 1.5 times the maximum base width dimension for concrete pad and chimney or steel grillage foundations; or
 - iii. 3m or 5 times shaft diameters (whichever is greater) below the foundation depth for drilled shaft, piled foundations; or
 - iv. at least 2m into rock or hard dense stratum (NSPT > 50) if this occurs before the recommended depth; or
 - v. for uplift or lateral foundation tests not less than 1m below the base of the test foundation.
- d) SPTs (standard penetration tests) should be undertaken at the top of each stratum and then at 1m intervals in soil or weak rock;
- e) PMTs (Pressure meter tests) should be undertaken in each stratum or as required;
- f) CPTs (Cone Penetration Tests) should be taken continuously over depth of investigation

- g) VSTs (Vane Shear Tests) should be undertaken at top of each stratum and then at 1m intervals;
- h) Soil/rock description should be based on disturbed samples taken in each stratum and thereafter at 1m intervals.
- i) Highest ground water level and variation in water level

7. QUALITY CONTROL OPGW

7.1 Types of Tests

Type, sample and routine tests shall be undertaken on the OPGW, their associated fittings, non-metallic underground fibre optic cable and optical fibres in accordance with the requirements of specification, CCITT G652, IEC 793 and IEC 794 as appropriate.

7.2 OPGW Tests

a) Fatigue

The Contractor shall submit documentary evidence to show the fatigue life of the OPGW including that of the optical sub-unit compared to that of a conventional conductor of similar characteristics. e.g. diameter, mass, stranding etc.

b) Stress-Strain

A sample of OPGW not less than 10m length, complete with the proposed end fittings shall be subject to a stress-strain test. The test shall be undertaken in accordance with IEC 1089 Annex B and the measuring techniques in accordance with IEC 794-1-E1.

c) Tensile performance

The test shall be undertaken in accordance with the load conditions specified in IEC 1089 Annex B and the measuring techniques in accordance with IEC 794-1-E1.

d) Crush and Impact

The test shall be undertaken in accordance with the recommendations of IEC 794-1-E3 and IEC 794-1-E4. The crush test shall be undertaken by applying a 10kN load for 1 minute to the OPGW via two 50mm x 50 mm flat plates. The impact test shall be undertaken by dropping a 4 kg weight from a height of 150 mm onto the end of a 20mm diameter steel mandrel placed on the OPGW. These should be done 20 times.

e) Temperature cycling

The optical performance under temperature cycling shall be tested in accordance with IEC 794-1-F1 with specified temperature ranges for a duration of 4 hours. The test should be undertaken twice.

f) Water Ingress

The optical sub-unit shall be tested for water ingress in accordance with IEC 794-1-F5

g) Fault Current

A sample of OPGW not less than 2 metres in length shall be subjected to a fault current pulse. The test shall be performed twice with an interval of 30 minutes between tests. After the second impulse the OPGW shall be dismantled and the optical cable examined throughout its length for any signs of deterioration.

h) Lightning Strike

Tests shall be carried out to verify the effectiveness of the OPGW to withstand the effects of a lightning strike. The test shall consider both an initial stroke and a follow through. The test shall be carried out on a sample of OPGW not less than 2 metres long. The acceptable criteria shall be that earthwires calculated residual strength is not less than 90 percent of the original stated ultimate strength.

7.3 Optical Fibres

Optical fibres shall be tested in accordance with the requirements of IEC 793.

7.4 Optical joint Boxes

Optical joint boxes shall be visually inspected to ensure they meet the specified requirements.

7.5 Non- metallic underground Fibre Optic cable

Non-metallic underground fibre optic cable and the optical fibres shall be tested in accordance with the requirements of IEC 793 and IEC 794 as appropriate.

7.6 Fibre Optic cable

All fibre optic cables shall be tested prior to dispatch using an OTDR on each fibre and other tests detailed in this document.

7.7 Test Certificates

Test records, covering type and sample tests shall be provided.

7.8 Test equipment

The following test equipment if specified in the price schedules shall be supplied and shall remain the property of the Employer after the completion of the site installation. The equipment shall be delivered to the Employer's site depot complete with suitable packaging after completion of the installation tests.

- h) One-Portable Optical Time Domain Reflectometer (OTDR) with 1300 and 1550 nm modules. Storage and printing capabilities of traces shall be provided;
- i) Two- Portable Optical Power meters for 1300 and 1550nm;
- j) Two- Portable High Stability Laser Sources for optical power measurements at 1300 and 1550 nm wavelengths:
- k) An optical fibre fusion splicing machine which shall be of the automatic type, designed to carry out fibre core alignment, pre-cleaning and fusion splicing as a fully integrated and properly co-ordinated sequence of functions. It shall only be necessary for the operator to correctly prepare the fibre ends and carry out preliminary alignment prior to initiating the splicing sequence. Optical devices and light sources that are utilised in the fibre system shall form an integral part of the fusion splicing machine and the alignment process. Devices that rely on the use of remotely mounted light sources will not be acceptable. The fusion splicing machine shall be capable of producing splices with an average attenuation value of less than 0.05dB.

8. MINIMUM CLEARANCES

Minimum Clearance of Live Parts to Towers is provided in Appendix 8.A.2

APPENDIX 8.A1

SPECIFICATIONS FOR THE COMPOSITE INSULATORS

No	Specifications	Suspension	Tension
1	Maximum System Voltage (kV)	145	145
2	Pollution Category	Heavy Pollution	Heavy pollution
3	Dielectric	Silicon rubber	Silicon rubber
4	One-minute power frequency withstand voltage, 50 Hz, wet. (kV)	275	275
5	Lighting impulse withstand voltage, 1,2/50 pos. (kV)	650	650
6	Power arc current	25 kA, 0.5 sec	
7	Minimum creepage distance (mm)	3700	3700
8	Specified mechanical load, tension (kN)	70	100
9	Minimum Arc Gap (mm)	1250	1250
10	Material fittings	Steel h.d.g	Steel h.d.g
11	Material of rod	E- CR Glass	E- CR Glass

12	Material of housing and sheds	HTV- Silicone	HTV Silicone
13	Socket	IEC 60120/16	IEC 60120/16
14	Ball	IEC 60120/16	IEC 60120/16
15	Arcing Rings material	Steel h.d.g	Steel h.d.g
16	Arcing rings	IEC 61284	IEC 61284

APPENDIX 8.A2

Minimum Clearances

Minimum clearance of live parts to towers

The minimum electrical clearances of live parts to earthed structures for the project shall be asfollows:

Minimum clearances	
a) In still air (Vertical position)	: 1350mm
b) Under 20° swing of suspension insulator set or jumper conductors	: 1350mm
c) Under 40° swing of suspension insulator set or jumper conductors	: 1140mm
d) Under 60° swing of suspension insulator set or jumper conductors	: 830mm

Minimum Ground clearances of conductors

Above general terrain	7.5m
Above main roads	8.5m
Above other Power lines	3.2m
Above other Telephone lines	3.2m
Above railways, SGR	8.5m, 15m

- Note:**
- i. *Actual minimum clearance to apply is in the design scope of the contractor considering the altitude, Climatic condition, loading, loading conditions and best engineering practices*
 - ii. *Minimum Phase to Phase, horizontal, Vertical and inclination distance to be considered for tower design is in the scope of contractor.*
 - iii. *Minimum sag difference between phase conductors and OPGW and Mid-span clearance between conductor and OPGW from a towers to another is in the scope of contractor.*
 - iv. *The Sag Error, Leg Extension requirement for tower design and Muff height between concrete and ground level are in the design scope of contractor considering the altitude, Climatic condition, loading, loading conditions and best engineering practices*
 - v. *Contractor shall take to consideration the altitude correction factor as per IEC standards.*

9. TOWERS

9.1 TYPE OF TOWER

Towers shall be self-supporting and broad base galvanised steel lattice type with body and hillside extensions. The hillside extensions shall be applied for tower legs on the slope so that legs are suited to the original slope of tower site and also that excessive land cutting around foundations and land collapse is prevented.

The following tower types shall be designed for the project in order to meet various tower positions and loadings economically.

- (a) Type-S : Use at tangential positions or angle points up to 2 degrees of horizontal deviation, provided with suspension type insulator sets.
- (b) Type-L : Use at positions of light angle up to 15 degrees of horizontal Angle deviation with tension type insulator sets.
- (c) Type-M : Use at positions of medium angle up to 30 degrees of horizontal angle deviation with tension insulator sets.
- (d) Type-H : Use at positions of heavy angle up to 60 degrees of horizontal angle deviation with tension insulator sets.
- (e) Type-HS : Use at positions of specifically heavy angle up to 75 degrees of horizontal angle deviation with tension type insulator sets.
- (f) Type-T : Use at positions of line termination (Dead end) or up to 90 degrees of horizontal angle deviation with tension type insulator sets.

9.2 TOWER DESIGN GENERAL ARRANGEMENT

Towers shall have the general arrangements and configurations shown in the drawings included with the specification. They shall be designed to resist the specified ultimate system loading. Clearances between live parts and supporting steelwork and between the phase conductors and ground or other obstacles shall be as specified.

All tower designs shall be such as to facilitate inspection, painting, maintenance, repairs and operation with the continuity of supply being the prime consideration.

The design shall be such that the number of different parts shall be as few as possible to facilitate transport, erection and inspection. The maximum weight of the heaviest single member should be limited to that within the normal lifting capability of the proposed erection equipment.

Main leg members of lattice steel towers shall be formed of the maximum single lengths appropriate to the body or leg extensions and shall not without the Employer's approval incorporate additional spliced sections.

For lattice steel towers a fully triangulated system of bracings shall preferably be adopted. If full triangulation is not adopted, the overall stability and secondary bending stresses must be considered in the design.

Where fabrication processes employed adversely affect the material properties, or introduce zones of high stress concentration the overall design of the structures shall take such factors into account.

Cross-arms shall be so arranged that they can be disconnected in the plane of the longitudinal face of the support without disturbing any members forming part of the support body.

The cross-arms should be designed to take and be compatible with the AB CHANCE Live Line maintenance tools and equipment.

Appropriate bird guard protective devices shall be installed to keep away birds from roosting directly over the insulator units.

9.2.1 Height of Towers

Height of towers shall be determined in the under-mentioned way:

$$H = Gc + Sg + Li + Hc + Hg$$

Where,

H = total height of tower

Gc = Necessary ground clearance of power conductors above ground or other objectives.

Sg = Maximum conductor sag for DC line

Li = Length of a suspension insulator set for DC line, but nil for a tension type towers.

Hc = Vertical spacing of upper conductor cross -arm spacing

Hg = Vertical spacing between upper conductor cross-arm and overhead earthwire.

Towers shall be provided with body extensions in a 3m step to a standard height for maintaining necessary conductor ground clearance mentioned in Appendix 8.A2 on various ground profiles. The maximum body extension will be 6m. In addition in the body extensions, each leg will have hillside extensions in a 1m step to suit for the original ground slope. Standard tower structures are shown in typical lattice tower drawing no.03 as well as insulation clearance diagram of conductors.

9.2.2 Design Span

The design of all towers shall provide for the following basic, wind and weight spans:

Type of Tower	S	L	M	H	HS	T
Basic span (m)	300	300	300	300	300	300
Wind span (m)	350	350	350	350	350	350
Weight span (m)	600	1,200	1,200	1,200	1,200	1,200
Uplift Weight (m)	0	-300	-300	-300	-300	-300

The term basic span means the horizontal distance between centres of adjacent supports on the level ground which the height of standard towers is derived with the specified conductor clearances to ground in still air at maximum temperature.

The term wind span means half the sum of adjacent horizontal span lengths supported on any one tower.

The term uplift weight means the weights of conductors and overhead earthwire supported upwards at any one tower for reinforcing strength of cross arms.

9.2.3 Design Loads

Structural loading shall refer, ASCE Manual and Report on Engineering Practice No.74 “guidelines for electrical transmission line structural loading”.

The following minimum loads shall be applied in the design of towers, actual site environmental loads (wind) with appropriate factors of safety will be used for detailed design:

(a) Wind Loads

- on power conductors and overhead earthwire :
385N/m²(on the projected area of conductor or wire)
- On tower structures : 690N/
m²(on the projected area of structure members)
- On insulator sets : 385N/ m²

(b) Maximum working Tensions of Conductor and Earthwire

- Power conductor Lynx : 22,500 N
- Overhead OPGW : 14,100 N

(c) Vertical Loads

- tower structures : actual weights of tower structures including accessories
- Power conductors : Weight of conductors of specified weight span with accessories

- Overhead OPGW : weight of specified weight span with accessories
 - Erection Loads : such loads as workers' weights on tower members, reaction of temporarily backstays during stringing operation, etc
- (d) **Horizontal Angle Effect**
- Power conductors and overhead earthwire : horizontal component of maximum working tension of conductors and earthwire due to the specified horizontal angle deviation.

The towers shall be designed for the following wind and weight spars.

TYPE OF TOWER	S	L	M	H	HS	T
Wind Span [m]						
- Normal working condition [m]	350	350	350	350	350	350
- Broken wire condition [m]	260	260	260	260	260	260
Weight Span [m]						
- Normal working condition [m]	700	1200	1200	1200	1200	1200
-Broken wire condition [m]	500	900	900	900	900	900
Uplift weight for cross arms	-	300	300	300	300	300

9.2.4 Design Conditions

a) **Assumed Normal Loading Condition:**

The assumed maximum simultaneous working loading on towers shall be as follows:

- (i) **Vertical loads** : as above-mentioned.
- (ii) **Transverse loads** : wind loads horizontal angle deviation effects
- (iii) **Longitudinal loads** :wind loads and erection loads but together with maximum working tensions of power conductors and overhead earthwire for their termination for Type-T tower.

(b) **Assumed Broken-Wire Condition:**

Under the condition, any one power conductor or an earthwire is assumed to be broken at their maximum working tensions in addition to the loads under the normal condition. In the case of Type-S tower, the pull will be assumed to be reduced to 70% of the specified maximum working tensions.

(c) **Factor of Safety:**

The following factors of safety for tower structures shall be applied in the design.

- (i) More than 2.5 for the synthetic maximum load under the normal loading condition.
- (ii) More than 1.25 for the synthetic maximum load under the broken-wire condition.

Those factors of safety shall be proved under tower loading tests on the proto-type towers in the manufacturer's testing station, and there should be no failure or permanent distortion during the tests.

Note: The given data are for guidance, maximum working tension data shall be obtained from design from design calculations considering the loading and conditions provided.

(d) Shield angle

The design shield angle for the OPGW shall be 30 degree, subject to contractor design confirmation. Parallel factors to be considered for the towers and Pilot insulator Swing angles shall be determined by the contractor considering the loads and loading conditions provided.

9.2.5 Design of Towers.

Latticed steel structures shall be designed with geometric configurations based on structural strength, electrical, economic, and safety requirements. Member forces caused by the design factored loads shall be determined by established principles of structural analysis.

Each type of towers shall be designed so that no failure or permanent distortion shall occur when tested with applied force equivalent to 2.5 times the maximum simultaneous working loadings specified in the Clause 10.2.4 [Normal Working Loading] and also equivalent to 1.25 times the maximum simultaneous working loadings resulting from the assumed broken wire condition.

Design loads shall consider:

- a) Minimum legislated levels
- b) Client specifications including factors of safety,
- c) Expected climatic conditions,
- d) Line security provisions,
- e) Design life of not less than 50 years,
- f) Construction and maintenance operations.

The ultimate design stress, obtained from the working stress multiplied by the factor of safety of 2.5 under the normal condition and 1.5 under the broken wire condition, in tension members shall not exceed the yield point of materials. The ultimate design stress, obtained from the working stress multiplied by the above mentioned factor of safety, in compression members shall not exceed a figure obtained from an approved formula to be entered in Tender based on the yield point of materials. Alternately, formulas in the American Society of Civil Engineers standard for the design of self-supporting latticed steel transmission structures ASCE 10- 97. Structural loading shall refer, ASCE Manual, BS 8100: Lattice Towers/masts Code of practice and Report on Engineering Practice No. 74 guidelines for electrical transmission line structural loading.

Tower design report shall consist of full structural analysis report showing correctness of dimensional detail calculations, tower profile/layout drawings, shop detail drawings, erection

drawings and bills of materials. Shop detail drawings shall be approved by the producing utility Engineer of Record (EOR) regarding compliance with the purchaser's specifications and the strength requirements of the design.

Designed tower full size prototype proof test to BS EN 60652:2004 "loading tests on overhead line structures "shall be conducted and approved before tower materials shop production and delivery to site.

Note: The Prototype tower Proof test shall be carried on one complete assembled tower of each type of the towers to be supplied in this project.

9.2.6 Materials and Fabrication.

The towers shall be fabricated from high tensile strength steel of the finest quality of which mechanical properties shall comply with Grade Fe 430 and Fe 510 as specified in ISO 630-1980 or Fe 510B/S355JR or equivalent the meets BS, IEC and ASTM standards.

No member of the tower shall be less than 6mm in thickness and 50mm in width of flange for leg members of towers and main members of the cross-arm, and 5mm and 45mm for the web and nominal members respectively.

The slenderness ratio shall not exceed 150 for the leg and arm members, 200 for the web members and 250 for the nominal members as compression member and 350 for tension only member.

All the connection shall be made by mild and/or high tensile steel bolts and nuts. No bolt shall be less than 12mm in diameter. All bolts and nuts shall be provided with approved spring washers. Antitheft bolts shall be used from ground level to the tower anti-climb level.

Bolt holes shall not be more than 1.5mm larger in diameter than the corresponding diameter of bolts. Holes shall be drilled for the members not less than 13 mm in thickness. For the members having thickness below 13 mm, holes may be drilled or punched, but the former is preferred.

All the steel members should have clearly identifiable part numbers which enable quick identification of similar parts. The letters '*REREC*' should also be inscribed on each bracing- by punching or any other suitable method, with more than one inscription for parts of length greater than 0.5m.

All burs shall be removed completely by reaming and smoothing before hot-deep galvanising.

9.3 TOWER ACCESSORIES

The following accessories shall be provided for every tower.

(i) **Anti-climbing device and climbing steps**

All towers will be provided with the anti-climb device on each leg at the height of 3 m to 5 m above the highest ground level at all tower locations. The device installed on the step-bolted legs shall be provided on

all towers. Gates shall be designed to open upwards only and shall be secured with galvanised bolts and nuts. No padlocks are required.

Each tower shall be provided with step-bolts of an approved type on diagonal sides of the tower at a spacing no more than 380mm, starting immediately above the anti-climbing device and continuing to the earth wires.

Step and anchor bolt shall be made of high strength steel grade 8.8 as per ISO 898-1:1999, BS 3692:2000, with minimum diameter: 5/8 inch (16mm) and Length: 8-9/16inch.

Holes for removal step-bolts below the anti-climbing guards shall be provided at not more than 380mm centres on the step legs.

Where the line is passing through forests inhabited by baboons as indicated in the ESMP document, the towers shall be provided with Racer and Barbed wires of approved type by the employer in addition to anti-climbing devices. These racer wires are made to deter the primates from climbing the towers and accessing the live conductors. The Racer and Barbed wires shall be installed at least 5m above the ground level.

The step-bolts shall also be installed on these towers as required in all the towers

(ii) **Danger, Number and Helicopter patrol plates**

Danger plate which shows warning sign for tower climbing of other people than maintenance crew will be provided on all towers.

Number plates which show tower number set serially from Mokowe (Mainland) to Manda Island will also be installed on every tower.

All plates shall be of anti-corrosive material. If enamelled iron plates are used, the whole surface of each plate including the back and edges shall be properly covered and resistant to corrosion. On all plates the colours shall be permanent and free from fading. With enamelled plates, washers or fibre or other approved material shall be provided back and front of the securing bolts.

(iii) **Tower Earthing**

No separate earth conductor from top to bottom of towers is required and earthing continuity will therefore depend on surface contact between bolted members.

All structures shall be provided with means for connecting earthing devices at or around nominal ground level, on each leg and for connecting earthwire bonds to each top crossarm or earthwire peak.

Each leg of towers will have an earthing rod underneath its foundation to act as basic grounding required by good transmission line Engineering. Basic grounding shall be constructed in such a way that isolation from the tower and concrete foundation is possible to allow earthing survey if required during line service life.

Maximum earthing resistance of a tower is targeted on 10 Ohms, and in case of higher resistance than 10 ohms, additional horizontal counterpoise earthing system will be added in the ground longitudinally to the line route with more than 50 cm depth. The rate entered in the schedule of prices shall include for all necessary fittings and shall be adjusted at the variation rate for increased or reduced fittings.

(iv) **Aircraft Warning Devices**

Due to the activity of aircraft in the vicinity of certain parts of the transmission line, it shall be necessary to mount warning spheres on earthwires at some locations. Aircraft warning spheres shall be capable of being clamped securely to overhead earthwire. The sphere itself shall be of plastic or fibreglass construction of at least 0.5m in diameter and coloured orange or yellow as required by local regulations. The Contractor is to enter rates against appropriate item in the schedule of prices for the above and he will be advised early in the contract of actual requirements.

(v) **Bolts**

Where appropriate all metal parts shall be secured with bolts and nuts with single spring washers. When in position the bolts shall project through the corresponding nuts by at least three threads, but such projections shall not exceed 10mm. No screwed threads shall form part of a shearing plane between members.

In order to safeguard the tower members from theft; special anti-theft bolts shall be applied from ground level up to 1 metre above the anti-climbing device. The bolts shall be approved by the Employer. The bolts are of the type that shears once the full torque has been applied.

The nuts of all bolts attaching phase conductor insulator set, earthwire sets, maintenance brackets/plates shall be locked in an approved manner preferably by locknuts.

The bolts of any one diameter in a tower shall be one grade of steel. Leg members shall be joined in such a way that electrical continuity is maintained to ground.

Bolts and Nuts shall be made of High tensile strength grade 8.8 or higher steel, and diameter shall be not less than 16mm as per BS3692:2000, ISO 898-1:1999

(vi) **Rectangular and Auxiliary Cross Arm**

The type H, HS and T towers may be provided with rectangular arms where horizontal angle exceeds 45 degree.

The prices of the rectangular arm set shall be included in the prices for the towers.

9.4 MATERIALS

All steel shall comply with BS EN 10025 or BS EN 10210 as appropriate, unless otherwise specified and shall be suitable for all the usual fabrication processes, including hot and cold working within the specified ranges.

The quality of finished steel shall be in accordance with BS EN 10163. All steel shall be free from blisters, scale, laminations, segregations and other defects. There shall be no rolling laps at toes of angles or rolled-in mill scale.

Unless specified to the contrary the following grades of steel shall be applicable:

- a) Mild steel shall be either grade S235JRG2 or S275JR.
- b) High tensile steel shall be grade S355JR for sections less than 20mm thick and S355JO for sections greater or equal to 20mm thick, except for plates which shall be greater or equal to 40mm thick.

9.5 WORKMANSHIP

All steel lattice members shall be cut to jig and all holes in steelwork shall be drilled or punched to jig. All steel parts shall be carefully cut and holes located so that when the members are in position the holes will be opposite each other before being bolted up. The drilling, cutting, punching and bending of all fabricated steelwork shall be such as to prevent any possibility of irregularity occurring which might introduce difficulty in the erection of structures on site. High tensile steel members shall be bent hot. Care shall be taken not to punch holes too close to the edge of members.

Means shall be provided to enable the Employer to carry out such checking of members, as he may consider necessary. Built-up sections, when finished, shall be true and free from all kinks, twists and open joints and the materials shall not be strained in any way.

In order to check the workmanship, not less than 1 per cent, of the members corresponding to each type of tower or cross arm shall be selected at random and assembled to form complete latticed supports or cross-arms in the presence of the Employer representative at the manufacturer's works.

10. CIVIL WORKS

9.1 CONCRETE FOUNDATIONS

General

Concrete pad/Block and chimney type foundations will be applied to most of the towers, the design of the concrete foundations of the towers shall be performed based on the requirements and assumptions set out below, and the details of the design and drawings for each type of foundations shall be submitted with the Tender.

The foundation design shall be depended on tower design, geotechnical survey, soil investigation to be done by the contractor and other design factors given in the subsequent clauses

Such design of foundations for the towers are subject to modifications to suit the site conditions as indicated in writing by the Engineer during execution of the Contract without any price adjustment of the items of the foundation stubs.

9.2 CONCRETE FOUNDATIONS: - PAD AND CHIMNEY

The types of the concrete foundations and natures of earth to be considered shall be as follows:-

Types of concrete foundation Assumed natures of earth Yield bearing capacity	L	M	H
- Vertical [ton/m ²]	60	40	20
- Lateral [ton/m ²]	30	20	10
Mass [kg/m ³]	1,600	1,500	1,400
Angle of frustum [degree]	30	20	10

All Structural Concrete shall be reinforced with steel bars to structural design details. Deformed steel bars are preferable for the reinforcement.

The depth of the foundations, concrete and steel grade is depended on each type of tower design and geotechnical investigations data obtained by contractor.

The abbreviations L, M and H of the concrete foundation types shall mean as follows:-

- L : Light concrete foundation
- M : Medium concrete foundation
- H : Heavy concrete foundation

The angle of frustum of earth shall mean the angle vertical of earth frustum to resist the uplift force.

The concrete to be considered shall conform to class C20/25 with a minimum strength of 25N/mm² at 28 days:-

Assumed natures of concrete

Following is the assumed nature of concrete to be considered;
 Allowable strength:

-Compressive	[kg/m ²]	60
-Tensile	[kg/m ²]	6.0
-Shearing	[kg/m ²]	6.0
Mass:		
-Concrete without reinforcement	[kg/m ³]	2,300
-Concrete with reinforcement	[kg/m ³]	2,400
Allowable strength on:		
-Galvanized steel action	[kξ]	
-Round reinforcing bars	[kξ]	

Each type of foundation shall be designed based on the following formula:

[1] Against compression load

$$\frac{q}{F} \geq \frac{C+G+Ws}{A}$$

Where,	q	:	Yield bearing capacity of earth [ton/m ²]
	F	:	Factor of safety
	C	:	Compressive load [ton]
	G	:	Weight of concrete [ton]
	Ws	:	Weight of earth above foundation pad [ton]
	A	:	Area of foundation pad [m ²]

[2] Against uplift load

$$\frac{T}{F} \leq Ws'$$

Where,	T	:	Uplift load [ton]
	Ws'	:	Weight of earth in frustum [ton]
	F	:	Factor of safety

[3] Against lateral load

$$\frac{q' \times A'}{F} \geq Q$$

Where,	Q	:	Horizontal load [t]
	q'	:	Yield lateral bearing capacity of earth [ton/m ²]
	A'	:	Projected area of foundation chimney and pad [m ²]

The factor of safety shall not less than 2.5 under the normal working conditions and 1.25 under the broken wire conditions.

The upper surfaces of the foundation pads shall be reinforced and sloped within 45 degrees to the horizontal. The minimum thickness of the edges of base pad shall be not less than 300mm. The frustum shall be assumed to start from the top edges of the pad. Where frustums overlap each other, allowance shall be made for loss of uplift resistance.

Concrete shall cover any part of the top steelwork by at least 100mm and shall extend above the ground for the minimum height of 350mm. Additional 500mm minimum chimney extension shall be provided to foot on lower side in sloping areas. The upper surface of chimney shall be sloped to ensure drainage of water.

The cleats shall be attached by bolting at the base of each stub to assist in transfer of leg load to the foundation pad as shown on drawing *Appendix 1.A3 (Anti-Climbing device and Grounding system)*. Minimum portion of stub loads in the design of cleats shall be assumed at 50 per cent.

9.3 SPECIAL FOUNDATIONS

Besides the mentioned above concrete foundations, special foundations such as raft type foundation, rock anchor, piled foundation or others may be required. Final type of foundation to be applied for each tower shall be determined in accordance with results of soil investigation performed by the Contractor during execution of the Contract.

For the purpose of tendering, basic designs shall be submitted with the tender under the following assumptions, and prices for the special foundations shall be quoted based on the design.

[a] Raft type foundation

The foundation shall be designed with the following specifications: ultimate bearing capacity of 10ton/m², soil weight of 1.4 ton/m³ and no angle of frustum of soil. Weights of reinforced concrete and soil shall be taken as entirely submerged. Other design conditions specified in this subsection will be applied. Contractor shall determine the applicable concrete density for submerged condition.

[b] Piled foundation

Piles used for the foundation shall be either pre-casted concrete pile with circular or square cross section or in-situ concrete pile.

[i] Pile data

Pile diameter or dimension

- Circular cross section	-	Φ300 mm.
- Square cross section	-	300 x 300 mm
Pile depth below ground level	-	12 m
Ratio or ultimate bearing/uplift capacity of pile-		2.5: 1

[ii] Uplift

The mass density of concrete below ground level shall be assumed as 1,600 kg/m³ to allow for hydrostatic effects and similarly soil as 960 kg/m³. Additional weight of concrete shall be included as necessary to provide the specified resistance to uplifting under any condition. Where bored or driven piles are proposed having no specially made bulb or enlarged concrete foot to provide positive uplift resistance but relying on skin friction alone, at least 75% of the networking uplift force, and 50% of the nett brokenwire uplift force shall be provided in dead weight of concrete, whichever is the greater.

The cost of such concrete shall be included in the piled foundation rate.

[iii] Compression

Mass density of concrete shall be assumed as 2,300 kg/m³ on their technical acceptability and cast.

Contractors must justify assumptions of equal performance of their piling system with that proposed. No extra payment shall be made for access tracks necessary for heavy piling rigs.

Piles shall be embedded in a reinforced concrete cap of adequate dimensions and the caps tied with nominal reinforced concrete beams of a minimum size of 460 mm deep by 300 mm wide with at least eight 19 mm diameter main reinforcing bars per beam.

Piling shall be carried out using an approved procedure throughout. The actual length and numbers of piles required at any given location shall be approved by the Engineer on the basis of the final agreed design data.

[c] Other Foundations

Where special ground conditions exist which do not allow for any of the above designs in an original or modified, special types of foundations may be employed. They will be paid for on basis of submitted rates schedule for concrete, steel and excavations applying throughout, irrespective of special conditions.

Tower prices shall cover for all costs not covered by special scheduled rates where admissible including the provision of access tracks and standings for piling equipment or building of bund for the Contractor's convenience in paddy fields or other flooded areas.

9.4 FOUNDATION WORKS

10.4.1 Soil Investigation

The Contractor shall make tests of subsoil conditions at every tower site by means of an approved simple hand-operated borer [sampling] and sounding tool, and indicate results on the approved soil test sheets together with ground water levels and proposed foundation type to be applied at the tower position.

The Contractor shall obtain the Engineer's approval for the foundation type in advance of the foundation works at each tower site. Particular note is to be made where any poor ground is encountered likely to require special foundations. The test results shall show firm evidences to prove reasons why the proposed type of foundation is selected from the specified foundation types. The cost of the sub-soil tests is deemed included in the rate for foundation work.

The Engineer may request the Contractor additional sub-soil tests at the bottom of excavated pits, if the Engineer judges its necessity for further confirmation on the proposed foundation types. The sub-soil tests shall be done at the earliest stage of the filed works to the urgency of having tower stubs and templates on site in order that foundation works can proceed with a minimum of delay. BS5930, soil investigation code will apply as a technical guide for reference.

10.4.2 Excavation and Backfilling

Where angle towers are fitted with unequal length cross arms at each side of the tower, the tower centre shall be offset to ensure that conductors are located as near as possible equidistant either side of the route centreline in adjacent spans.

The Contractor shall ensure that excavations are made to the correct depth and width. If excavations are taken deeper than the designed dimension the excess depth shall be backfilled with concrete at the Contractor's expense. If excavations are made wider than the designed dimension, such modifications to the design as the Engineer may require shall be made at the Contractor's expense.

For uplift foundations, undercutting or other approved method shall be applied as far as possible for allowing upward bearing of the foundation pad against undisturbed soil for a minimum width of 250mm all around. Alternatively the concrete pad shall be cast to the edge of the excavation for a minimum height of 250 mm in order to gain assistance by adhesion to the original ground. In cases where the concrete block is cast in undercutting, the earth frustum assumed to resist uplift shall be considered to start from the bottom of the vertical edges of the block. Otherwise, the frustum shall be assumed to start from the upper top of the block edges.

The backfill of all types of foundations shall be thoroughly rammed with mechanical rammers, and the ramming shall be carried out at intervals of not greater than 300 mm to ensure thorough consolidation of the backfill as the Engineer requires.

Foundation Concrete faces shall be painted with an approved bituminous paint to separate backfill from concrete before backfilling.

In no circumstances shall peat, black Cotton soil or equivalent materials be used as backfill for foundations. Where excavations are made in peat ground, backfilling to be foundations shall be made with a suitable soil or hard-core from an approved source at the Contractor's expense. Backfill shall be finished in such that the original ground contours are restored as nearly as possible, any subsidence of backfill shall be made good before the issue of the Taking-Over Certificate.

10.4.3 Stub Setting

Stubs for tower foundations shall only be installed with the use of templates, probes or by use of the lower sections of the tower with the suitable temporary bracings to ensure correct spacing.

The stub setting templates shall be of approved type with sufficient rigidity to ensure correct setting of the stubs. The method selected shall be such that all four stubs are supported and interconnected by a rigid steel framework. The main members of the templates must be in the position by the template while the concrete is placed. The templates are not to be removed until at 48 hours after the foundations have been completed.

The templates shall be manufactured from mild steel angle or channel or a combination of both, of approved and adequate cross-section, and shall be equipped with central alignment notches or holes, corner braces, riser-braces, and stub angle bolting legs to permit the accurate setting of stubs in respect of the following requirements:

- i) Longitudinal centreline
- ii) Tower lateral centreline
- iii) Stub elevations [with reference to datum]
- iv) Stub levelling
- v) Inclinations of stubs
- vi) Stub hip bevels
- vii) Spacing between stubs

No concrete shall be started before the stubs are confirmed to be in the design positions, setting details recorded in setting out form.

10.4.4 Concrete Works

- [a] Concrete for concrete foundation and pile shall have the minimum required breaking strengths as specified in the technical schedules. BS 5328 will refer when specifying concrete and BS 8110 in reference to structural use of concrete
- [b] Cement used shall be Portland with minimum strength of 42.5 KN/m² or other approved composition obtained from an approved maker. Portland cement shall conform in all respects to BS-12.
- [c] Aggregates shall be clean and free from dust, earthy or organic matter or salt. Coarse aggregate shall be approved grading to be retained on a mesh not less than 5mm square, and of a maximum size to pass a mesh not more than 40 mm square. Where specially approved in writing by the Engineer, coarse aggregate of uniform size which will pass a 25mm mesh may be used throughout. Fine aggregate shall be river sand and shall be coarse, sharp, clean and free from dust, salt, clay, vegetable matter or other impurity and shall be screened through a mesh not more than 5mm in the clear. It shall be well graded mixture of coarse and fine grains from 5mm gauge downwards. Aggregates shall conform in all ways to BS812 and KS 95:2003.
- [d] Water shall be clean and free from all earth, vegetable or organic matter, salt, soil, oil, acid and alkaline substances either in solution or in suspensions. Quality shall be confirmed by lab test as per BS 3148 (Mixing Water Specifications).
- [e] At least four weeks before commencing any concreting work, the Contractor shall make trial mixes using samples of cement and fine and coarse aggregates.

The test specimens for the trial mixes shall be of cube type. Preliminary test specimens shall be taken from the proposed mixes as follows:

For each proposed mix a set of 6 specimens shall be made from each of 3 consecutive batches. Three from each set of six shall be tested at an age of seven [7] days and three [3] at an age of 28 days. The test shall be carried out in an approved laboratory.

Neither the mix proportions nor the source of supply of materials shall be altered without the prior approval of the Engineer except that the Contractor shall adjust the proportions of the mix as required, to take account of permitted variations in the materials, such approval shall be subject to the execution, to the Engineer's satisfaction, of trial mix procedures set out herein.

- [f] Where directed by the Engineer concrete cubes are to be taken and tested to verify the concrete strength during site concreting works. The Contractor shall provide the cube moulds at site for this purpose accordingly. The test specimens shall be 150 mm cubed and the mould shall be of metal with inner faces accurately machined in order that opposite sides of the specimen are plane and parallel. Each mould shall be provided with the metal base having a smooth machined surface. The interior surfaces of the mould and base should be lightly oiled before concrete is placed in the mould.
- [g] The cost of concrete testing shall be deemed to be included in the Contractor's general schedule rates. Testing Lab shall be approved
- [h] Requirements for testing concrete samples during construction are set out in Clause 11.8.
- [i] The concrete shall thoroughly wetted before backfilling commences. When shutters are to be struck, backfilling of excavation is not to take place immediately, and the concrete shall be kept continuously moist to avoid rapid drying.
- [j] In the event that the Contractor proposes to use ready mixed concrete for foundation work, approval must first be obtained from the Engineer, who will inspect the batching plant and cement, sand and gravel used for concrete. No ready mixed concrete shall be used in foundation work if it has been mixed in the lorry during its journey for more than 45 minutes. At the discretion of the Engineer, ready mixed concrete may be used in foundations in excess of 45 minutes journey, if the cement is added to the drum at site and is thoroughly mixed prior to placing, or alternatively if the ready mixing lorry carried its own drum during the lorry's journey and not mixed for more than 45 minutes prior to placing. The Engineer's decision to reject any of the above methods of supplying ready mixed concrete shall be final.
- [k] Throughout the line route, the Contractor shall at regular intervals and at the time of survey, obtain samples of subsoil and ground water, which he shall have analysed to ascertain if any agents be present which may have an adverse effect on concrete made with normal Portland cement. The analyses shall be forwarded to the Engineer without delay together with any recommendations for the use of special cement. The Engineer's decision as to the type of cement to be used will be final. The cost of obtaining soil and ground

water samples is deemed to be included in the Contract Price. The cost of any special cement used will be paid at an appropriate rate to be agreed with the Engineer.

- [1] Concrete shall be placed immediately after mixing. All concrete shall be thoroughly compacted by vibration during the operation of placing, and shall be free from honeycombing and other defects. The upper surface of the concrete for all types of foundations shall be finished smooth and sloped in an approved manner to prevent accumulation of water. A concrete additive of a type approved by the Engineer may be used.

10.4.5 Piling and Other Special Works

Piling will be carried out using an approved procedure throughout. The actual length and numbers of piles required at any location will be approved by the Engineer on the basis of the final agreed design data and payment made for departures from the assumed tender design quantities on the basis of the difference of quantities times the Schedule variation rates. Piles shall be tested in accordance with Clause 11.8. Tender Prices shall include for all necessary casings, pumping, and depreciation of piling machines, materials, transportation, testing and others.

Where special ground conditions exist which do not allow for any of the designs in an original or modified form, special types of foundations may be employed which will be paid for on the basis of schedule rates submitted. To this extent the submitted schedule of rates for concrete, steel and excavations shall apply throughout irrespective of special conditions.

9.5 ERECTION OF TOWERS

Where tower members arrive on site with slight distortions due to handling in transit, they shall be straightened by the Contractor using approved means and offered to the Engineer for inspection and acceptance or rejection before erection commences.

In general, towers shall be assembled and erected with bolts finger tight only. Final tightening of bolts shall only take place when all members are in place. As far as practical, bolts shall be inserted with the nuts facing outwards or downwards.

Whenever wire slings or ropes are liable to abrade tower members, the members shall be suitably protected by heavy Hessian bags or strips, or by some other approved means.

The Contractor shall make use of temporary struts on panels prior to lifting, if in the opinion of the Engineer, there is likelihood of damage occurring to that panel during lifting. Where derricks are used for lifting panel they shall be securely guyed and shall be supported only at approved locations on the legs.

All towers shall be vertical under the stress set up by the completed overhead line to the satisfaction of the Engineer. The maximum acceptable deviation from vertical shall normally be 1%.

Proper precautions shall be taken to ensure that no parts of the towers or supports are unduly stressed or damaged in any way during erection. Drifting shall not be allowed.

Suitable ladders shall be used whenever necessary during erection, but such ladders and removal step bolts shall be removed when erection work is in progress.

Before assembly of members, joints shall be free of all earth, or any other substances which might prevent the correct alignment of members. After erection, all materials shall be cleaned of all foreign matter or surplus paint.

Spanners used during erection shall be well shaped and fit closely on the nut to avoid damaging nuts and bolt heads. Approved equipment shall be used for tightening the shear bolts which will be used from ground level up to one metre above the anti-climbing devices. After erection, the rest of the bolts up to the bottom cross arm shall have the threads smashed in an approved manner to prevent unauthorized removal.

Damage to the galvanised surfaces of bolts, tower steelwork or smashed bolts shall be repaired using zinc rich paint or similar and the cost of such repair is deemed to be included in the appropriate rates.

The Contractor must ensure that tower erection, steel handling and operation of equipment shall be such as to ensure the maximum safety of all personnel associated with the project as well as the public.

Lower parts of towers erected in the submerged area during wet seasons shall be protected from corrosion with an approved paint as ordered by the Engineer. The cost for the paint shall be quoted in the Price Schedule.

9.6 GROUNDING OF TOWERS

Before placing foundation concrete, basic grounding earthing rods specified in Clause 11.8 shall be erected to each foundation cleats. Installation shall ensure that earthing can be isolated from the tower and concrete foundation to allow earthing survey. Measurement of footing resistances of all towers shall be carried out with an approved instrument before stringing of an overhead earthwire. A target value of the resistance is less than **10 Ohms**. The Contractor shall report the measured value in an approved form to the Engineer. The Engineer will instruct necessitate of installation of counterpoises to the Contractor who shall then provide the counterpoises as specified in the Clause 11.8 to the instructed towers and measure the resistances for reporting the Engineer. In case the resistance is still high, the Engineer may order the Contractor to install additional counterpoises.

9.7 ERECTION OF CONDUCTOR AND OVERHEAD EARTHWIRE

- a) The fullest possible use shall be made of the maximum conductor lengths in order to reduce the number of joints to the minimum. The number and location of conductor and overhead earthwire tension joints shall be approved. Tension joints shall not be less than 15m from the nearest clamp.
- b) Unless the Engineer agrees to the contrary, mid span joints shall not be used-
 - (i) at locations which would allow less than 3 clear spans between mid-span joints on a given conductor and wire

(ii) in spans crossing power lines, telecommunications lines, public roads or buildings, and
(iii) in single span sections.

- c) Conductor repair sleeves shall not be used without the permission of the Engineer, which will be granted only in exceptional circumstances.
- d) Conductor and earthwire stringing shall be carried out entirely by tension stringing methods and the Contractor shall submit for approval full details of the precise method of tension stringing and of the stringing equipment which he intends to use. Conductors shall be kept off the ground at all times when the conductor is in motion. The method of tension stringing required to install all conductors and earthwire shall be continuously controlled.
- e) The conductor and earthwire tension during stringing operation shall be kept as low as possible, consistent with keeping the conductor and earthwire clear of the ground whilst in motion. At no time will the tensions be allowed to exceed 75% of the final tension.
- f) All stringing equipment shall be properly anchored and shall be positioned in such a way that structures, insulators and fittings will not be overloaded.
- g) Conductor and earthwire drums shall be securely anchored during the stringing operation and drum jacks shall be of the self-braking type to prevent conductor over run.
- h) Conductor and earthwire pulling shall be such as will ensure a continuously steady pull. Every precaution is to be taken to prevent damage to the conductor and earthwire. Clamps and other devices used for handling conductor and earthwire during erection shall allow no slippage or relative movement of strands or layers and shall not pinch or deform the conductor and earthwire. Grooves in sheaves and tensioners shall be lined with neoprene or rubber. Sheaves shall have an electrical conducting path between their suspension points and the conductor supported within them and shall run with minimum friction.
- i) Conductor and earthwire shall be effectively earthed in an approved manner during running out and at all places where men are working on them.
- j) At least three months before stringing commences, the Contractor shall give due consideration to all the factors involved and submit to the Engineer for approval a fully detailed stringing schedule stating locations of conductor and earthwire drums, winch operation for stringing and the proposed positions of mid-span joints, together with temporary staying wires of towers and all other relevant information.
- k) Conductor and earthwire drums shall be closely examined before conductor pulling commences and all nails and other things which could damage the conductors and earthwires shall be removed. During stringing, the conductor and earthwire drums are to be supervised at all times and the conductor and earthwire shall be inspected for defects while it is being pulled off the drums. Any damage caused to conductors or earthwires shall be reported to the Engineer whose decision to replace or repair will be final.
- l) Conductors and earthwires shall be carefully regulated to the correct prestress and initial tensions by a measurement of sags. Ambient temperature shall be measured by a

thermometer suspended on the tower at the sag measurement position. Making for and application of anchor clamps shall follow regulation to initial tension without delay. Immediately after regulation and clamping has been completed in a section, the sag of conductors and earthwire shall not depart from the correct value by more than $\pm 1.5\%$. Suspension insulator sets shall be installed so that clamps are within 20mm of their correct position on the conductor.

- m) The insulators strings shall be cleaned and inspected before assembly. Any defective insulator be shall be removed from site forthwith. Insulators have the security clip, cotter pins and other locking devices fully in place and shall be erected in a manner avoiding damage to the sheds, fibre-glass rod or locking devices.
- n) Where required by the Engineer, the Contractor shall check prior to the issue of the Taking- Over Certificate that the sags of conductors and earthwire in selected spans are within the specified tolerance, and shall make any adjustment necessary to ensure compliance.
- o) Joints, clamps, etc. shall be applied using the approved tools and in such a manner that no bird-caging, over-tensioning of individual wires or layers or other deformation or damage to the conductor and earthwire occurs. Cutting of layers of conductors shall be carried out with tools designed to prevent damage to underlying strands.
- p) Compression fittings shall be applied only by linemen approved by the Engineer, using approved methods. The outer surfaces of conductors and earthwires and the interiors of compression sleeves shall be scratched-brushed immediately before assembly.
- q) After conductors have been made off and landed, stringing sheaves shall be removed and suspension clamps and vibration dampers shall be fitted with minimum delay. Suspension clamps shall be fitted with due regard to offsets where appropriate, and the conductor and earthwire shall be cleaned before the clamp is assembled.
- r) The Conductor shall keep a record of all sagging showing details of the section, the sagging and checking spans, ambient temperature, pre-stress, initial and final sags, the date of sagging and clipping-in offset, etc. This record shall form part of the final records for the line and shall be handed over to the Engineer prior to the issue of taking-Over Certificate. The records shall be available for inspection at any time.

9.8 TESTS AT SITE

[1] General

Following investigations and tests shall be carried out by the Contractor, when ordered by the Engineer.

Those investigations and tests as mentioned in the Price schedule will be paid for at the rates entered. Other investigations and tests not scheduled in the Price Schedule shall be deemed to be included in the prices of the relative items of the works.

[2] Ground Probe Tests

Tests by means of an approved type of penetrometer or other approved means shall be carried out during the check survey as provided for in Clause 11.4. Results of these tests shall be submitted to the Engineer on an approved form giving a preliminary indication of the ground bearing properties and water levels, etc. Bore penetration shall be at least 9m below ground level in poor ground.

[3] Laboratory Soil Tests

Where ordered by the Engineer, the Contractor shall obtain soil samples and submit these for tests to an approved laboratory to determine the necessary properties of the soils for the purpose of foundation designs. Such information shall be detailed in an approved manner and conclusions given as to the recommended bearing pressures to be adopted. Tests shall be carried out generally in the manner described in BS-1377

[4] Ground Bearing Test

Where ordered by the Engineer, the Contractor shall carry out ground bearing tests to determine the ground bearing capacity, by means of loading a 300 mm square plate in an approved manner. Tests shall be carried out generally in the manner described in BS-5930.

[5] Pile Bearing and Uplift Tests

Where ordered by the Engineer, the Contractor shall carry out pile bearing and uplift tests for all types of pile generally in accordance with the method given in the BS CP-2004. Such tests shall be carried out to determine the ultimate uplift and bearing values.

[6] Foundation Loading Tests

Where ordered by the Engineer, foundation loading tests shall be carried out in full scaled individual footings.

[7] Records of Site Investigation Tests

All records of site investigation tests shall be detailed in an approved manner. Sample log sheets, charts, etc. shall be submitted to the Engineer for approval before any investigation commences. All site investigation data, charts, etc. shall be handed over to the Engineer in triplicate upon satisfactory conclusion of the tests, and before the issue of Taking-Over Certificate.

Where the Contractor carried out other tests at his own expense, not ordered by the Engineer, and to the contrary, where the Employer had independent tests made along the route of the line, such information shall be made available to the Contractor.

[8] Concrete Tests

The Contractor shall carry out tests on sample of concrete from the foundation works, as required by the Engineer as specified in Clause 11.4. The test specimens shall be stored at the site at a place free from vibration under damp sacks for 24 hours. They shall be then removed from the moulds, marked and stored in water at a temperature between 10^o C and 21^o C until the testing date. Specimens which are to be sent to a laboratory for testing shall be packed for transit in a

damp sand, or other suitable damp materials, and shall be brought in the laboratory at least 24 hours before test. On arrival at the laboratory, they shall be similarly stored in water until the time of the test.

The results shall be handed in triplicate to the Engineer, as soon as possible after testing, and not later than seven days.

[9] Support Footing Resistance

The resistance to earth of the complete foundation of individual structures shall be measured in an approved manner before the stringing operation of overhead earthwire, as specific in Clause

11.6. The placing of tests electrodes shall normally be along the centre line of the route in such direction as to ensure that the lowest resistance to earth is recorded, and a note shall be made of the direction in the time of the test.

[10] Additional Footing Resistance Test

If in the opinion of the Engineer, it is necessary to reduce the tower footing resistance by means of counterpoises, the Contractor shall make further measurement after the additional counterpoises have been carried out before the stringing operation of the overhead earthwire. Any further measurement shall be carried out as necessary without extra charge.

[11] Measurement of Galvanising Thickness

The Contractor shall have on site an instrument suitable for accurate checking of galvanizing thickness for the Engineer's use. The gauge shall be available from time of arrival of the first consignment of steel work until the issue of Taking-Over Certificate. The cost of the gauge and other operating expenses shall be deemed to be included in the contract price and the gauge shall remain the property of the Employer.

[12] Testing of Rock Anchors

Where rock anchor foundations are used in hard rock, as provided for by the Engineer's order, the Contractor shall test individual anchors by tensile test loading to failure for obtaining design data of the foundations. The test shall be considered satisfactory if the steel bar fails by yielding at or above its ultimate strength.

Anchor for the testing shall be installed away from permanent foundation anchors but in the same rock. The frequency of the test shall depend upon the different types of hard rock encountered and the number of tests performed shall be such as to give confidence in the employment of rock anchor foundations and experience of the type of rock suitable for their use. The frequency of test shall, in the case of dispute, be reasonably determined by the Engineer. Tests shall be carried out generally in the manner described in BS-8081 on ground anchorages. The cost rock test shall be included in the relevant schedule rates.

[13] Test on Completion

The line along the towers shall be energized at full working voltage before handing over, and the arrangement for this and such other test as the Employer/ Engineer shall desire to make on the completed line shall be assisted by the Contractor who shall provide such labour, transport and other assistance as required without extra charge.

PART 3 – CONDITIONS OF CONTRACT AND CONTRACT FORMS

GENERAL CONDITIONS OF CONTRACT

A. Contract and Interpretation

1.1 Definitions

In this Contract, except where context otherwise requires, the following terms shall be interpreted as indicated below. Words indicating persons or parties include corporations and other legal entities, except where the context requires otherwise.

“Accepted Contract Amount” means the amount accepted in the Letter of Acceptance for the execution and completion of the Works and the remedying of any defects.

“Base Date” means a date 30 day prior to the submission of tenders.

“Bill of Quantities” means the priced and completed Bill of Quantities forming part of the tender. **“Completion Date”**

meansthe date of completion of the Works as certified by the Engineer.

“Contract Price” means the price defined in the contract and there after as adjusted in accordance with the provisions of the Contract.

“Contract” means the agreement entered into between the Procuring Entity and the Contractor as recorded in the Agreement Form and signed by the parties including all attachments and appendices thereto and all documents incorporated by reference therein to execute, complete, and maintain the Works.

“Contractor's Documents” means the calculations, computer programs and other software, progress reports, drawings, manuals, models and other documents of a technical nature (if any) supplied by the Contractor under the Contract.

“Contractor's Equipment” means all apparatus, machinery, vehicles and other things required for the execution and completion of the Works and the remedying of any defects. However, Contractor's Equipment excludes Temporary Works, Procuring Entity's Equipment (if any), Plant, Materials and any other things intended to form or forming part of the Permanent Works.

“Contractor's Personnel” means the Contractor's Representative and all personnel whom the Contractor utilizes on Site, who may include the staff, labor and other employees of the Contractor and of each Subcontractor; and any other personnel assisting the Contractor in the execution of the Works.

“Contractor's Representative” means the person named by the Contractor in the Contractor appointed from time to time by the Contractor who acts on behalf of the Contractor.

“Contractor” means the person(s) named as contractor in the Form of Tender accepted by the Procuring Entity.

“Cost” means expenditure reasonably incurred (or to be incurred) by the Contractor, whether on or off the Site, including overhead and similar charges, but does not include profit.

“Day” means a calendar day and **“year”** means 365 days.

“Dayworks” means Work inputs subject to payment on a time basis for labour and the associated materials and plant.

“Defect” means any part of the Works not completed in accordance with the Contract.

“Defects Liability Certificate” means the certificate issued by Architect upon correction of defects by the Contractor.

“Defects Liability Period” means the period named in the Special Conditions of Contract and calculated from the Completion Date, within which the contractor is liable for any defects that may develop in the handed over works.

“Defects Notification Period” means the period for notifying defects in the Works or a Section (as the case may be) under Sub-Clause 11.1 [Completion of Outstanding Work and Remedying Defects], which extends over the days stated in the Special Conditions of Contract.

“Drawings” means the drawings of the Works, as included in the Contract, and any additional and modified drawings issued by (or on behalf of) the Procuring Entity in accordance with the Contract.

“Final Payment Certificate” means the payment certificate issued under Sub-Clause 14.13 [Issue of Final Payment Certificate].

“Final Statement” means the statement defined in Sub-Clause 14.11

[Application for Final Payment Certificate]. **“Force Majeure”** is defined in Clause 19 [Force Majeure].

“Foreign Currency” means a currency of another country (not Kenya) in which part (or all) of the Contract Price is payable, but not the Local Currency.

“Goods” means Contractor's Equipment, Materials, Plant and Temporary Works, or any of them as appropriate.

“Interim Payment Certificate” means a payment certificate issued under Clause 14 [Contract Price and Payment], other than the Final Payment Certificate.

“Laws” means all national legislation, statutes, ordinances, and regulations and by-laws of any legally constituted public authority.

“Letter of Acceptance” means the letter of formal acceptance of a tender, signed by Procuring Entity, including any annexed memoranda comprising agreements between and signed by both Parties.

“Local Currency” means the currency of Kenya.

“Materials” means things of all kinds (other than Plant) intended to form or forming part of the Permanent Works, including the supply-only materials (if any) to be supplied by the Contractor under the Contract.

“Notice of Dissatisfaction” means the notice given by either Party to the other under Sub-

Clause 20.3 indicating its dissatisfaction and intention to commence arbitration.

“Special Conditions of Contract” means the pages completed by the Procuring Entity entitled Special Conditions of Contract which constitute Part A of the Special Conditions.

“Party” means the Procuring Entity or the Contractor, as the context requires.

“Payment Certificate” means a payment certificate issued under Clause 14 [Contract Price and Payment]. **“Performance Certificate”** means the certificate issued under Sub-Clause 11.9

[Performance Certificate]. **“Performance Security”** means the security (or securities, if any) under Sub-Clause 4.2 [Performance Security]. **“Permanent Works”** means the permanent works to be executed by the Contractor under the Contract.

“Plant” means the apparatus, machinery and other equipment intended to form or forming part of the Permanent Works, including vehicles purchased for the Procuring Entity and relating to the construction or operation of the Works.

“Procuring Entity's Equipment” means the apparatus, machinery and vehicles (if any) made available by the Procuring Entity for the use of the Contract or in the execution of the Works, as stated in the Specification; but does not include Plant which has not been taken over by the Procuring Entity.

“Procuring Entity's Personnel” means the Engineer, the Engineer, the assistants and all other staff, labor and other employees of the Architect and of the Procuring Entity; and any other personnel notified to the Contractor, by the Procuring Entity or the Engineer, as Procuring Entity's Personnel.

“Procuring Entity” means the Entity named in the Special Conditions of Contract.

“Engineer” is the person named in the Appendix to Conditions of Contract (or any other competent person appointed by the Procuring Entity and notified to the Contractor, to act in replacement of the Engineer) who is responsible for supervising the execution of the Works and administering the Contract and shall be an “Architect” or a “Quantity Surveyor” registered under the Architects and Quantity Surveyors Act Cap 525 or an “Engineer” registered under Engineers Registration Act Cap 530.

“Engineer” means the person appointed by the Procuring Entity to act as the Architect for the purposes of the Contract and named in the Special Conditions of Contract, or other person appointed from time to time by the Procuring Entity and notified to the Contractor

“Provisional Sum” means a sum (if any) which is specified in the Contract as a provisional sum, for the execution of any part of the Works or for the supply of Plant, Materials or services under Sub-Clause 13.5 [Provisional Sums].

“Retention Money” means the accumulated retention moneys which the Procuring Entity retains under Sub-Clause 14.3 [Application for Interim Payment Certificates] and pays under Sub-Clause 14.9 [Payment of Retention Money].

“Schedules” means the document(s) entitled schedules, completed by the Contractor and

submitted with the Form of Tender, as included in the Contract.

“Section” means a part of the Works specified in the Special Conditions of Contract as a Section (if any)

“Site Investigation Reports” are those reports that may be included in the tendering documents which are actual and interpretative about the surface and sub-surface conditions at the Site.

“Site” means the places where the Permanent Works are to be executed, including storage and working areas, and to which Plant and Materials are to be delivered, and any other places as may be specified in the Contract as forming part of the Site.

“Specification” means the document entitled specification, as included in the Contract, and any additions and modifications to the specification in accordance with the Contract. Such document specifies the Works.

“Start Date” or **“Commencement Date”** is the latest date when the Contractor shall commence execution of the Works. It does not necessarily coincide with the Site possession date(s).

“Statement” means a statement submitted by the Contractor as part of an application, under Clause 14 [Contract Price and Payment], for a payment certificate.

“Subcontractor” means any person named in the Contract as a subcontractor, or any person appointed as a subcontractor, for a part of the Works.

“Taking-Over Certificate” means a certificate issued under Clause 10 [Procuring Entity's Taking Over].

“Temporary Works” means all temporary works of every kind (other than Contractor's Equipment) required on Site for the execution and completion of the Permanent Works and the remedying of any defects.

“Temporary works” means works designed, constructed, installed, and removed by the Contractor which are needed for construction or installation of the Works.

“Tender” means the Form of Tender and all other documents which the Contractor submitted with the Form of Tender, as included in the Contract.

“Tests after Completion” means the tests (if any) which are specified in the Contract and which are carried out in accordance with the Specification after the Works or a Section (as the case may be) are taken over by the Procuring Entity.

“Tests on Completion” means the tests which are specified in the Contract agreed by both Parties or instructed as a Variation, and which are carried out under Clause 9 [Tests on Completion] before the Works or a Section (as the case may be) are taken over by the Procuring Entity.

“Time for Completion” means the time for completing the Works or a Section (as the case may be) as stated in the Special Conditions of Contract (with any extension calculated from the Commencement Date).

“Unforeseeable” means not reasonably foreseeable by an experienced contractor by the Base

Date.

“Variation” means any change to the Works, which is instructed or approved as a variation under Clause 13 [Variations and Adjustments].

“Works” means the items the Procuring Entity requires the Contractor to undertake as defined in the Appendix to Conditions of Contract. **“Works”** may also mean the Permanent Works and the Temporary Works, or either of them as appropriate.

1.2 Interpretation

In the Contract, except where the context requires otherwise:

- a) Words indicating one gender include all genders;
- b) words indicating the singular also include the plural and words indicating the plural also include the singular;
- c) provisions including the word “agree”, “agreed” or “agreement” require the agreement to be recorded in writing;
- d) “written” or “in writing” means hand-written, type-written, printed or electronically made, and resulting in a permanent record; and

The marginal words and other headings shall not be taken into consideration in the interpretation of these Conditions.

1.3 Communications

1.3.1 Wherever these Conditions provide for the giving or issuing of approvals, certificates, consents, determinations, notices, requests and discharges, these communications shall be:

- a) In writing and delivered by hand (against receipt), sent by mail or courier, or transmitted using any of the agreed systems of electronic transmission as stated in the Special Conditions of Contract; and
- b) delivered, sent or transmitted to the address or the recipient's communications as stated in the Special Conditions of Contract. However:
 - i) if the recipient gives notice of another address, communications shall thereafter be delivered accordingly; and
 - ii) if the recipient has not stated otherwise when requesting an approval or consent, it may be sent to the address from which the request was issued.

1.3.2 Approvals, certificates, consents and determinations shall not be unreasonably withheld or delayed. When a certificate is issued to a Party, the certifier shall send a copy to the other Party. When a notice is issued to a Party, by the other Party or the Engineer, a copy shall be sent to the Architect or the other Party, as the case may be.

1.4 Law and Language

1.4.1 The Contract shall be governed by the laws of **Kenya**.

1.4.2 The ruling language of the Contract shall be **English**.

1.5 Priority of Documents

The documents forming the Contract are to be taken as mutually explanatory of one another. For the purposes of interpretation, the priority of the documents shall be in accordance with

the following sequence:

- a) The Contract Agreement,
- b) The Letter of Acceptance,
- c) The Special Conditions – Part A,
- d) the Special Conditions – Part B
- e) the General Conditions of Contract
- f) the Form of Tender,
- g) the Specifications and Bills of Quantities
- h) the Drawings, and
- i) the Schedules and any other documents forming part of the Contract.

If an ambiguity or discrepancy is found in the documents, the Architect shall issue any necessary clarification or instruction.

1.6 Contract Agreement

The Parties shall enter into a Contract Agreement within 14 days after the Contractor receives the Contract Agreement, unless the Special Conditions establish otherwise. The Contract Agreement shall be based upon the form annexed to the Special Conditions. The costs of stamp duties and similar charges (if any) imposed by law in connection with entry into the Contract Agreement shall be borne by the Procuring Entity.

1.7 Assignment

The Contractor shall not assign the whole or any part of the Contract or any benefit or interest in or under the Contract. However, the contractor:

- a) May assign the whole or any part with the prior consent of the Procuring Entity, and
- b) may, as security in favor of a bank or financial institution, assign its right to moneys due, or to become due, under the Contract.

1.8 Care and Supply of Documents

- 1.8.1 The Specifications and Drawings shall be in the custody and care of the Procuring Entity. Unless otherwise stated in the Contract, two copies of the Contract and of each subsequent Drawings and Bills of Quantities shall be supplied to the Contractor, who may make or request further copies at the cost of the Contractor.
- 1.8.2 Each of the Contractor's Documents shall be in the custody and care of the Contractor, unless and until taken over by the Procuring Entity. Unless otherwise stated in the Contract, the Contractor shall supply to the Architect two copies of each of the Contractor's Documents.
- 1.8.3 The Contractor shall keep, on the Site, a copy of the Contract, publications named in the Specification, the Contractor's Documents (if any), the Drawings and Variations and other communications given under the Contract. The Procuring Entity's Personnel shall have the right of access to all these documents at all reasonable times.
- 1.8.4 If a Party becomes aware of an error or defect in a document which was prepared for use in executing the Works, the Party shall promptly give notice to the other Party of such error or defect.

1.9 Timely provision of Drawings or Instructions

- 1.91 The Contractor shall give notice to the Architect whenever the Works are likely to be delayed or disrupted if any necessary drawing or instruction is not issued to the Contractor within a particular time, which shall be reasonable. The notice shall include details of the necessary drawing or instruction, details of why and by when it should be issued, and the nature and amount of the delay or disruption likely to be suffered if it is late.
- 1.92 If the Contractor suffers delay and/or incurs Cost as a result of a failure of the Architect to issue the notified drawing or instruction within a time which is reasonable and is specified in the notice with supporting details, the Contractor shall give a further notice to the Architect and shall be entitled subject to Sub-Clause 20.1 [Contractor's Claims] to:
- a) an extension of time for any such delay, if completion is or will be delayed, under Sub-Clause 8.4 [Extension of Time for Completion], and
 - b) payment of any other associated costs accrued, which shall be included in the Contract Price.
- 1.93 After receiving this further notice, the Architect shall proceed in accordance with Sub-Clause 3.5 [Determinations] to agree or determine these matters.
- 1.94 However, if and to the extent that the Architect failure was caused by any error or delay by the Contractor, including an error in, or delay in the submission of, any of the Contractor's Documents, the Contractor shall not be entitled to such extension of time, or costs accrued.

1.10 Procuring Entity's Use of Contractor's Documents

- 1.101 As agreed between the Parties, the Contractor shall retain the copyright and other intellectual property rights in the Contractor's Documents and other design documents made by (or on behalf of) the Contractor.
- 1.102 The Contractor shall be deemed (by signing the Contract) to give to the Procuring Entity a non-terminable transferable non-exclusive royalty-free license to copy, use and communicate the Contractor's Documents, including making and using modifications of them. This license shall:
- a) apply throughout the actual or intended working life (whichever is longer) of the relevant parts of the Works,
 - b) entitle any person in proper possession of the relevant part of the Works to copy, use and communicate the Contractor's Documents for the purposes of completing, operating, maintaining, altering, adjusting, repairing and demolishing the Works, and
 - c) in the case of Contractor's Documents which are in the form of computer programs and other software, permit their use on any computer on the Site and other places as envisaged by the Contract, including replacements of any computers supplied by the Contractor.
- 1.103 The Contractor's Documents and other design documents made by (or on behalf of) the Contractor shall not, without the Contractor's consent, be used, copied or

communicated to a third party by (or on behalf of) the Procuring Entity for purposes other than those permitted under Sub-Clause 1.10.2.

1.11 Contractor's Use of Procuring Entity's Documents

As agreed between the Parties, the Procuring Entity shall retain the copyright and other intellectual property rights in the Specification, the Drawings and other documents made by (or on behalf of) the Procuring Entity. The Contractor may, at his cost, copy, use, and obtain communication of these documents for the purposes of the Contract. They shall not, without the Procuring Entity's consent, be copied, used or communicated to a third party by the Contractor, except as necessary for the purposes of the Contract.

1.12 Confidential Details

1.12.1 The Contractor's and the Procuring Entity's Personnel shall ensure confidentiality at all times. The confidentiality shall survive termination or completion of the contract. They shall disclose all such confidential and other information as may be reasonably required in order to verify compliance with the Contract and allow its proper implementation.

1.12.2 The Contractor's and the Procuring Entity's Personnel shall also treat the details of the Contract as private and confidential, except to the extent necessary to carry out their respective obligations under the Contract or to comply with applicable Laws. Each of them shall not publish or disclose any particulars of the Works prepared by the other Party without the previous agreement of the other Party. However, the Contractor shall be permitted to disclose any publicly available information, or information otherwise required to establish his qualifications to compete for other projects.

1.13 Compliance with Laws

The Contractor shall, in performing the Contract, comply with applicable Laws. Unless otherwise stated in the Special Conditions of Contract:

- a) The Procuring Entity shall have obtained (or shall obtain) the planning, zoning, building permit or similar permission for the Permanent Works, and any other permissions described in the Specifications as having been (or to be) obtained by the Procuring Entity; and the Procuring Entity shall indemnify and hold the Contractor harmless against and from the consequences of any failure to do so; and
- b) the Contractor shall give all notices, pay all taxes, duties and fees, and obtain all permits, licenses and approvals, as required by the Laws in relation to the execution and completion of the Works and the remedying of any defects; and the Contractor shall indemnify and hold the Procuring Entity harmless against and from the consequences of any failure to do so, unless the Contractor is impeded to accomplish these actions and shows evidence of its diligence.

1.14 Joint and Several Liability

If the Contractor constitutes (under applicable Laws) a joint venture, consortium or other unincorporated grouping of two or more persons:

- a) These persons shall be deemed to be jointly and severally liable to the Procuring Entity for the performance of the Contract;
- b) these persons shall notify the Procuring Entity of their leader who shall have authority to bind the Contractor and each of these persons; and
- c) the Contractor shall not alter its composition or legal status without the prior consent of the Procuring Entity.

1.15 Inspections and Audit by the Procuring Entity

Pursuant to paragraph 2.2(e). of Appendix B to the General Conditions, the Contractor shall permit and shall cause its subcontractors and sub-consultants to permit, the Public Procurement Regulatory Authority, Procuring Entity and/or persons appointed or designated by the Government of Kenya to inspect the Site and/or the accounts and records relating to the procurement process, selection and/or contract execution, and to have such accounts and records audited by auditors appointed by the Procuring Entity if requested by the Procuring Entity. The Contractor's and its Subcontractors' and sub-consultants' attention is drawn to Sub-Clause 15.6 (Fraud and Corruption) which provides, inter alia, that acts intended to materially impede the exercise of the Procuring Entity's inspection and audit rights constitute a prohibited practice subject to contract termination (as well as to a determination of ineligibility pursuant to the Procuring Entity's prevailing sanctions procedures).

2 THE PROCURING ENTITY

2.1 Right of Access to the Site

211 The Procuring Entity shall give the Contractor right of access to, and possession of, all parts of the Site within the time (or times) stated in the **Special Conditions of Contract**. The right and possession may not be exclusive to the Contractor. If, under the Contract, the Procuring Entity is required to give (to the Contractor) possession of any foundation, structure, plant or means of access, the Procuring Entity shall do so in the time and manner stated in the Specification. However, the Procuring Entity may withhold any such right or possession until the Performance Security has been received.

212 If no such time is stated in the Special Conditions of Contract, the Procuring Entity shall give the Contractor right of access to, and possession of, the Site within such times as required to enable the Contractor to proceed without disruption in accordance with the programme submitted under Sub-Clause 8.3 [Programme].

213 If the Contractor suffers delay and/or incurs Cost as a result of a failure by the Procuring Entity to give any such right or possession within such time, the Contractor shall give notice to the Architect and shall be entitled subject to Sub-Clause 20.1 [Contractor's Claims] to:

- a) an extension of time for any such delay, if completion is or will be delayed, under Sub-Clause 8.4 [Extension of Time for Completion], and
- b) payment of any such Cost-plus profit, which shall be included in the Contract Price.

214 After receiving this notice, the Architect shall proceed in accordance with Sub-Clause 3.5 [Determinations] to agree or determine these matters.

215 However, if and to the extent that the Procuring Entity's failure was caused by any error or delay by the Contractor, including an error in, or delay in the submission of, any of the Contractor's Documents, the Contractor shall not be entitled to such extension of time, Cost or profit.

2.2 *Permits, Licenses or Approvals*

221 The Procuring Entity shall provide, at the request of the Contractor, such reasonable assistance as to allow the Contractor to obtain properly:

- a) Copies of the Laws of Kenya which are relevant to the Contract but are not readily available, and
- b) any permits, licenses or approvals required by the Laws of Kenya:
 - i) which the Contractor is required to obtain under Sub-Clause 1.13 [Compliance with Laws],
 - ii) for the delivery of Goods, including clearance through customs, and
 - iii) for the export of Contractor's Equipment when it is removed from the Site.

2.3 *Procuring Entity's Personnel*

The Procuring Entity shall be responsible for ensuring that the Procuring Entity's Personnel and the Procuring Entity's other contractor son the Site:

- a) co-operate with the Contractor's efforts under Sub-Clause 4.6 [Co-operation], and
- b) take action ssimilar to those which the Contractor is required to take under sub-paragraphs (a), (b) and (c) of Sub-Clause 4.8 [Safety Procedures] and under Sub-Clause 4.18 [Protection of the Environment].

2.4 *Procuring Entity's Financial Arrangements*

The Procuring Entity shall make and maintain all necessary financial arrangements which will enable the Procuring Entity to pay the Contract Price punctually (as estimated at that time) in accordance with Clause 14 [Contract Price and Payment].

3 *THE ENGINEER*

3.1 *Architect Duties and Authority*

311 The Procuring Entity shall appoint the Architect who shall carry out the duties as signed to him in the Contract. The Architect staff shall include suitably qualified Assistants and other professionals who are competent to carry out these duties. The Architect Name and Address shall be provided in the **Special Conditions of Contract**.

312 The Architect shall have no authority to amend the Contract.

313 The Architect May exercise the authority attributable to the Architect as specified in or necessarily to be implied from the Contract. If the Architectis required to obtain the approval of the Procuring Entity before exercising a specified authority, the requirements shall be as stated in the **Special Conditions of Contract**. The Procuring

Entity shall promptly inform the Contractor of any change to the authority attributed to the Engineer.

314 However, whenever the Architect exercises a specified authority for which the Procuring Entity's approval is required, then (for the purposes of the Contract) the contractor shall require the Architect to provide evidence of such approval before complying with the instruction.

315 Except as otherwise stated in these Conditions:

- a) Whenever carrying out duties or exercising authority, specified in or implied by the Contract, the Architect shall be deemed to act for the Procuring Entity;
- b) the Architect has no authority to relieve either Party of any duties, obligations or responsibilities under the Contract;
- c) any approval, check, certificate, consent, examination, inspection, instruction, notice, proposal, request, test, or similar act by the Architect (including absence of disapproval) shall not relieve the Contractor from any responsibility he has under the Contract, including responsibility for errors, omissions, discrepancies and non-compliances; and
- d) any act by the Architect in response to a Contractor's request shall be notified in writing to the Contractor within 14 days of receipt.

316 The following provisions shall apply:

The Architect shall obtain the specific approval of the Procuring Entity before taking action under the following Sub-Clauses of these Conditions:

- a) Sub-Clause 4.1.2: agreeing or determining an extension of time and/or additional cost.
- b) Sub-Clause 13.1: instructing a Variation, except;
 - i) In an emergency situation as determined by the Engineer, or
 - ii) If such a Variation would increase the Accepted Contract Amount by less than the percentage specified in the **Special Conditions of Contract**.
- c) Sub-Clause 13.3: Approving a proposal for Variation submitted by the Contractor in accordance with Sub Clause 13.1 or 13.2.
- d) Sub-Clause 13.4: Specifying the amount payable in each of the applicable three currencies.

317 Notwithstanding the obligation, as set out above, to obtain approval, if, in the opinion of the Engineer, an emergency occurs affecting the safety of life or of the Works or of adjoining property, he may, without relieving the Contractor of any of his duties and responsibility under the Contract, instruct the Contractor to execute all such work or to do all such things as may, in the opinion of the Engineer, be necessary to abate or reduce the risk. The Contractor shall forthwith comply, despite the absence of approval of the Procuring Entity, with any such instruction of the Engineer. The Architect shall determine an addition to the Contract Price, in respect of such instruction, in accordance with Clause 13 and shall notify the Contractor accordingly, with a copy to the Procuring Entity.

3.2 *Delegation by the Engineer*

- 3.21 The Architect may from time to time assign duties and delegate authority to assistants and may also revoke such assignment or delegation. These assistants may include a resident Engineer, and/or independent inspectors appointed to inspect and/ or test items of Plant and/or Materials. The assignment, delegation or revocation shall be in writing and shall not take effect until copies have been received by both Parties. However, unless otherwise agreed by both Parties, the Architect shall not delegate the authority to determine any matter in accordance with Sub-Clause 3.5 [Determinations].
- 3.22 Each assistant, to whom duties have been assigned or authority has been delegated, shall only be authorized to issue instructions to the Contractor to the extent defined by the delegation. Any approval, check, certificate, consent, examination, inspection, instruction, notice, proposal, request, test, or similar act by an assistant, in accordance with the delegation, shall have the same effect as though the act had been an act of the Engineer. However:
- a) Any failure to disapprove any work, Plant or Materials shall not constitute approval, and shall therefore not prejudice the right of the Architect to reject the work, Plant or Materials;
 - b) If the Contractor questions any determination or instruction of an assistant, the Contractor may refer the matter to the Engineer, who shall promptly confirm, reverse or vary the determination or instruction.

3.3 *Instructions of the Engineer*

- 3.31 The Architect may issue to the Contractor (at anytime) instructions and additional or modified Drawings which may be necessary for the execution of the Works and the remedying of any defects, all in accordance with the Contract. The Contractor shall only take instructions from the Engineer, or from an assistant to whom the appropriate authority has been delegated under Clause 3.2.1.
- 3.32 The Contractor shall comply with the instructions given by the Architect or delegated assistant, on any matter related to the Contract. Whenever practicable, their instructions shall be given in writing. If the Architect or a delegated assistant:
- a) Gives an oral instruction,
 - b) receives a written confirmation of the instruction, from (or on behalf of) the Contractor, within two working days after giving the instruction, and
 - c) does not reply by issuing a written rejection and/or instruction within two working days after receiving the confirmation,

Then the confirmation shall constitute the written instruction of the Architect or delegated assistant (as the case may be).

3.4 *Replacement of the Engineer*

If the Procuring Entity intends to replace the Engineer, the Procuring Entity shall, in not less than 21 days before the intended date of replacement, give notice to the Contractor of the name, address and relevant experience of the intended person to replace the Engineer.

3.5 *Determinations*

3.5.1 Whenever these Conditions provide that the Architect shall proceed in accordance with this Sub-Clause 3.5 to agree or determine any matter, the Architect shall consult with each Party in an endeavor to reach agreement. If agreement is not achieved, the Architect shall make a fair determination in accordance with the Contract, taking due regard of all relevant circumstances.

3.5.1 The Architect shall give notice to both Parties of each agreement or determination, with supporting particulars, within 30 days from the receipt of the corresponding claim or request except when otherwise specified. Each Party shall give effect to each agreement or determination unless and until revised under Clause 20 [Claims, Disputes and Arbitration].

4 *THE CONTRACTOR*

4.1 *Contractor's General Obligations*

4.1.1 The Contractor shall design (to the extent specified in the Contract), execute and complete the Works in accordance with the Contract and with the Architect instructions, and shall remedy any defects in the Works.

4.1.2 The Contractor shall provide the Plant and Contractor's Documents specified in the Contract, and all Contractor's Personnel, Goods, consumables and other things and services, whether of a temporary or permanent nature, required in and for this design, execution, completion and remedying of defects.

4.1.3 All equipment, material, and services to be incorporated in or required for the Works shall have their origin in any eligible source country.

4.1.4 The Contractor shall be responsible for the adequacy, stability and safety of all Site operations and of all methods of construction. Except to the extent specified in the Contract, the Contractor (i) shall be responsible for all Contractor's Documents, Temporary Works, and such design of each item of Plant and Materials as is required for the item to be in accordance with the Contract, and (ii) shall not otherwise be responsible for the design or specification of the Permanent Works.

4.1.5 The Contractor shall, whenever required by the Engineer, submit details of the arrangements and methods which the Contractor proposes to adopt for the execution of the Works. No significant alteration to these arrangements and methods shall be made without this having previously been notified to the Engineer.

4.1.6 If the Contract specifies that the Contractor shall design any part of the Permanent Works, then unless otherwise stated in the Special Conditions:

- a) The Contractor shall submit to the Architect the Contractor's Documents for this part in accordance with the procedures specified in the Contract;
- b) these Contractor's Documents shall be in accordance with the Specification and Drawings, shall be written in the language for communications defined in Sub-Clause 1.4 [Law and Language], and shall include additional information required by the Architect to add to the Drawings for co-ordination of each Party's designs;
- c) the Contractor shall be responsible for this part and it shall, when the Works are completed, be fit for such purposes for which the part is intended as are specified in the Contract; and
- d) prior to the commencement of the Tests on Completion, the Contractor shall

submit to the Architect the “as-built” documents and, if applicable, operation and maintenance manuals in accordance with the Specification and in sufficient detail for the Procuring Entity to operate, maintain, dismantle, reassemble, adjust and repair this part of the Works. Such part shall not be considered to be completed for the purposes of taking-over under Sub-Clause 10.1 [Taking Over of the Works and Sections] until these documents and manuals have been submitted to the Engineer.

4.2 *Performance Security*

- 4.21 The Contractor shall obtain (at his cost) a Performance Security for proper performance, in the amount stated in the **Special Conditions of Contract** and denominated in the currency (ies) of the Contract or in a freely convertible currency acceptable to the Procuring Entity. If an amount is not stated in the Special Conditions of Contract, this Sub-Clause shall not apply.
- 4.22 The Contractor shall deliver the Performance Security to the Procuring Entity within 30 days after receiving the Notification of Award and shall send a copy to the Engineer. The Performance Security shall be issued by a reputable bank selected by the Contractor and shall be in the form annexed to the Special Conditions, as stipulated by the Procuring Entity in the Special Conditions of Contract, or in another form approved by the Procuring Entity.
- 4.23 The Contractor shall ensure that the Performance Security is valid and enforceable until the Contractor has executed and completed the Works and remedied any defects. If the terms of the Performance Security specify its expiry date, and the Contractor has not become entitled to receive the Performance Certificate by the date 30 days prior to the expiry date, the Contractor shall extend the validity of the Performance Security until the Works have been completed and any defects have been remedied.
- 4.24 The Procuring Entity shall not make a claim under the Performance Security, except for amounts to which the Procuring Entity is entitled under the Contract.
- 4.25 The Procuring Entity shall indemnify and hold the Contractor harmless against and from all damages, losses and expenses (including legal fees and expenses) resulting from a claim under the Performance Security to the extent to which the Procuring Entity was not entitled to make the claim.
- 4.26 The Procuring Entity shall return the Performance Security to the Contractor within 14 days after receiving a copy of the Taking-Over Certificate.
- 4.27 Without limitation to the provisions of the rest of this Sub-Clause, whenever the Architect determines an addition or a reduction to the Contract Price as a result of a change in cost and/ or legislation, or as a result of a Variation, amounting to more than 25 percent of the portion of the Contract Price payable in a specific currency, the Contractor shall at the Architect request promptly increase, or may decrease, as the case may be, the value of the Performance Security in that currency by an equal percentage.

4.3 *Contractor's Representative*

- 4.31 The Contractor shall appoint the Contractor's Representative and shall give him all authority necessary to act on the Contractor's behalf under the Contract. The

Contractor's Representative's Name and Address shall be provided in the **Special Conditions of Contract**.

- 4.3.2 Unless the Contractor's Representative **is named in the Contract**, the Contractor shall, prior to the Commencement Date, submit to the Architect for consent the name and particulars of the person the Contractor proposes to appoint as Contractor's Representative. If consent is withheld or subsequently revoked in terms of Sub-Clause 6.9 [Contractor's Personnel], or if the appointed person fails to act as Contractor's Representative, the Contractor shall similarly submit the name and particulars of another suitable person for such appointment.
- 4.3.3 The Contractor shall not, without the prior consent of the Engineer, revoke the appointment of the Contractor's Representative or appoint another person in place of the Contractor's Representative.
- 4.3.4 The whole time of the Contractor's Representative shall be given to directing the Contractor's performance of the Contract. If the Contractor's Representative is to be temporarily absent from the Site during the execution of the Works, a suitable replacement person shall be appointed, subject to the Architect's prior consent, and the Architect shall be notified accordingly.
- 4.3.5 The Contractor's Representative shall, on behalf of the Contractor, receive instructions under Sub-Clause 3.3 [Instructions of the Engineer].
- 4.3.6 The Contractor's Representative may delegate any powers, functions and authority to any competent person, and may at any time revoke the delegation. Any delegation or revocation shall not take effect until the Architect has received prior notice signed by the Contractor's Representative, naming the person and specifying the powers, functions and authority being delegated or revoked.
- 4.3.7 The Contractor's Representative shall be fluent in the language for communications defined in Sub-Clause 1.4 [Law and Language]. If the Contractor's Representative's delegates are not fluent in the said language, the Contractor shall make a competent interpreter available during all working hours in a number deemed sufficient by the Engineer.

4.4 *Sub-contractors*

- 4.4.1 The Contractor shall not subcontract the whole of the Works. The Contractor may however subcontract the works as provided in Clause 34.2.
- 4.4.2 The Contractor shall be responsible for the acts or defaults of any Subcontractor, his agents or employees, as if they were acts or defaults of the Contractor. Unless otherwise stated in the Special Conditions:
- a) The Contractor shall not be required to obtain consent to suppliers solely of Materials, or to a subcontract for which the Subcontractor is named in the Contract;
 - b) The prior consent of the Procuring Entity shall be obtained to other proposed Subcontractors;
 - c) the Contractor shall give the Procuring Entity not less than 14 days' notice of the intended date of the commencement of each Subcontractor's work, and of the commencement of such work on the Site; and
 - d) each subcontract shall include provisions which would entitle the Procuring Entity to require the subcontract to be assigned to the Procuring Entity under Sub-Clause 4.5 [Assignment of Benefit of Subcontract] (if or when applicable)

or in the event of termination under Sub-Clause 15.2 [Termination by Procuring Entity].

4.4.3 The Contractor shall ensure that the requirements imposed on the Contractor by Sub-Clause 1.12 [Confidential Details] apply equally to each Subcontractor.

4.4.4 Where practicable, the Contractor shall give fair and reasonable opportunity for contractors from Kenya to be appointed as Subcontractors.

4.5 *Assignment of Benefit of Subcontract*

If a Subcontractor's obligations extend beyond the expiry date of the relevant Defects Notification Period and the Engineer, prior to this date, instructs the Contractor to assign the benefit of such obligations to the Procuring Entity, then the Contractor shall do so. Unless otherwise stated in the assignment, the Contractor shall have no liability to the Procuring Entity for the work carried out by the Subcontractor after the assignment takes effect.

4.6 *Co-operation*

4.6.1 The Contractor shall, as specified in the Contract or as instructed by the Engineer, allow appropriate opportunities for carrying out work to:

- a) The Procuring Entity's Personnel,
- b) Any other contractors employed by the Procuring Entity, and
- c) The personnel of any legally constituted public authorities, who may be employed in the execution on or near the Site of any work not included in the Contract.

4.6.2 Any such instruction shall constitute a Variation if and to the extent that it causes the Contractor to suffer delays and/or incur Unforeseeable Cost. Services for these personnel and other contractors may include the use of Contractor's Equipment, Temporary Works or access arrangements which are the responsibility of the Contractor.

4.6.3 If, under the Contract, the Procuring Entity is required to give to the Contractor possession of any foundation, structure, plant or means of access in accordance with Contractor's Documents, the Contractor shall submit such documents to the Architect in the time and manner stated in the Specification.

4.7 *Setting Out of the Works*

4.7.1 The Contractor shall set out the Works in relation to original points, lines and levels of reference specified in the Contract notified by the Engineer. The Contractor shall be responsible for the correct positioning of all parts of the Works, and shall rectify any error in the positions, levels, dimensions or alignment of the Works.

4.7.2 The Procuring Entity shall be responsible for any errors in these specified or notified items of reference, but the Contractor shall use reasonable efforts to verify their accuracy before they are used.

4.7.3 If the Contractor suffers delay and/or incurs Cost from executing work which was necessitated by an error in these items of reference, and an experienced contractor

could not reasonably have discovered such error and avoided this delay and/ or Cost, the Contractor shall give notice to the Architect and shall be entitled subject to Sub-Clause 20.1 [Contractor's Claims] to:

- a) an extension of time for any such delay, if completion is or will be delayed, under Sub-Clause 8.4 [Extension of Time for Completion], and
- b) payment of any such costs accrued, which shall be included in the Contract Price.

4.7.4 After receiving this notice, the Architect shall proceed in accordance with Sub-Clause 3.5 [Determinations] to agree or determine (i) whether and (if so) to what extent the error could not reasonably have been discovered, and (ii) the matters described in sub-paragraphs (a) and (b) above related to these.

48 *Safety Procedures*

The Contractor shall:

- a) Comply with all applicable safety regulations,
- b) Take care for the safety of all persons entitled to be on the Site,
- c) Use reasonable efforts to keep the Site and Works clear of unnecessary obstruction so as to avoid danger to these persons,
- d) provide fencing, lighting, guarding and watching of the Works until completion and taking over under Clause 10 [Procuring Entity's Taking Over], and
- e) provide any Temporary Works (including roadways, footways, guards and fences) which may be necessary, because of the execution of the Works, for the use and protection of the public and of owners and occupiers of adjacent land.

49 *Quality Assurance*

4.9.1 The Contractor shall institute a quality assurance system to demonstrate compliance with the requirements of the Contract. The system shall be in accordance with the details stated in the Contract. The Architect shall be entitled to audit any aspect of the system.

4.9.2 Details of all procedures and compliance documents shall be submitted to the Architect or information before each design and execution stage is commenced. When any document of a technical nature is issued to the Engineer, evidence of the prior approval by the Contractor itself shall be apparent on the document itself.

Compliance with the quality assurance system shall not relieve the Contractor of any of his duties, obligations or responsibilities under the Contract.

4.10 *Site Data*

4.10.1 The Procuring Entity shall have made available to the Contractor for his information, prior to the Base Date, all relevant data in the Procuring Entity's possession on sub-surface and hydrological conditions at the Site, including environmental aspects. The Procuring Entity shall similarly make available to the Contractor all such data which come into the Procuring Entity's possession after the Base Date. The Contractor shall be responsible for interpreting all such data.

4.10.2 To the extent which was practicable (taking account of cost and time), the Contractor shall be deemed to have obtained all necessary information as to risks, contingencies and other circumstances which may influence or affect the Tender or Works. To the

same extent, the Contractor shall be deemed to have inspected and examined the Site, its surroundings, the above data and other available information, and to have been satisfied before submitting the Tender as to all relevant matters, including (without limitation):

- a) The form and nature of the Site, including sub-surface conditions,
- b) the hydrological and climatic conditions,
- c) the extent and nature of the work and Goods necessary for the execution and completion of the Works and the remedying of any defects,
- d) the Laws, procedures and labour practices of Kenya, and
- e) the Contractor's requirements for access, accommodation, facilities, personnel, power, transport, water and other services.

4.11 Sufficiency of the Accepted Contract Amount

4.11.1 The Contractor shall be deemed to:

- a) Have satisfied itself as to the correctness and sufficiency of the Accepted Contract Amount, and
- b) have based the Accepted Contract Amount on the data, interpretations, necessary information, inspections, examinations and satisfaction as to all relevant matters referred to in Sub-Clause 4.10 [Site Data].

4.11.2 Unless otherwise stated in the Contract, the Accepted Contract Amount covers all the Contractor's obligations under the Contract (including those under Provisional Sums, if any) and all things necessary for the proper execution and completion of the Works and the remedying of any defects.

4.12 Unforeseeable Physical Conditions

4.12.1 In this Sub-Clause, "physical conditions" means natural physical conditions and man-made and other physical obstructions and pollutants, which the Contractor encounters at the Site when executing the Works, including sub-surface and hydrological conditions but excluding climatic conditions.

4.12.2 If the Contractor encounters adverse physical conditions which he considers to have been Unforeseeable, the Contractor shall give notice to the Architect as soon as practicable.

4.12.3 This notice shall describe the physical conditions, so that they can be inspected by the Architect and shall set out the reasons why the Contractor considers them to be Unforeseeable. The Contractor shall continue executing the Works, using such proper and reasonable measures as are appropriate for the physical conditions, and shall comply with any instructions which the Architect may give. If an instruction constitutes a Variation, Clause 13 [Variations and Adjustments] shall apply.

4.12.4 If and to the extent that the Contractor encounters physical conditions which are Unforeseeable, gives such a notice, and suffers delay and/or incurs Cost due to these conditions, the Contractor shall be entitled subject to notice under Sub-Clause 20.1

[Contractor's Claims] to:

- a) an extension of time for any such delay, if completion is or will be delayed, under Sub-Clause 8.4 [Extension of Time for Completion], and
- b) payment of any such Cost, which shall be included in the Contract Price.

4.125 Upon receiving such notice and inspecting and/or investigating these physical conditions, the Architect shall proceed in accordance with Sub-Clause 3.5 [Determinations] to agree or determine (i) whether and (if so) to what extent these physical conditions were Unforeseeable, and (ii) the matters described in sub-paragraphs (a) and (b) above related to this extent.

4.126 However, before additional Cost is finally agreed or determined under sub-paragraph (ii), the Architect may also review whether other physical conditions in similar parts of the Works (if any) were more favorable than could reasonably have been foreseen when the Contractor submitted the Tender. If and to the extent that these more favorable conditions were encountered, the Architect may proceed in accordance with Sub-Clause 3.5 [Determinations] to agree or determine the reductions in Cost which were due to these conditions, which may be included (as deductions) in the Contract Price and Payment Certificates. However, the net effect of all adjustments under sub-paragraph (b) and all these reductions, for all the physical conditions encountered in similar parts of the Works, shall not result in a net reduction in the Contract Price.

4.127 The Architect shall take account of any evidence of the physical conditions foreseen by the Contractor when submitting the Tender, which shall be made available by the Contractor, but shall not be bound by the Contractor's interpretation of any such evidence.

4.13 Rights of Way and Facilities

Unless otherwise specified in the Contract the Procuring Entity shall provide effective access to and possession of the Site including special and/or temporary rights-of-way which are necessary for the Works. The Contractor shall obtain, at his risk and cost, any additional rights of way or facilities outside the Site which he may require for the purposes of the Works.

4.14 Avoidance of Interference

4.14.1 The Contractor shall not interfere unnecessarily or improperly with:

- a) The convenience of the public, or
- b) The access to and use and occupation of all roads and foot paths, irrespective of whether they are public or in the possession of the Procuring Entity or of others.

4.14.2 The Contractor shall indemnify and hold the Procuring Entity harmless against and from all damages, losses and expenses (including legal fees and expenses) resulting from any such unnecessary or improper interference.

4.15 Access Route

- 4.15.1 The Contractor shall be deemed to have been satisfied as to the suitability and availability of access routes to the Site at Base Date. The Contractor shall use reasonable efforts to prevent any road or bridge from being damaged by the Contractor's traffic or by the Contractor's Personnel. These efforts shall include the proper use of appropriate vehicles and routes.
- 4.15.2 Except as otherwise stated in these Conditions:
- a) The Contractor shall (as between the Parties) be responsible for any maintenance which may be required for his use of access routes;
 - b) the Contractor shall provide all necessary signs or directions along access routes, and shall obtain any permission which may be required from the relevant authorities for his use of routes, signs and directions;
 - c) the Procuring Entity shall not be responsible for any claims which may arise from the use or otherwise of any access route;
 - d) the Procuring Entity does not guarantee the suitability or a availability of particular access routes; and
 - e) Costs due to non-suitability or non-availability, for the use required by the Contractor, of access routes shall be borne by the Contractor.

4.16 Transport of Goods

Unless otherwise stated in the Special Conditions:

- a) the Contractor shall give the Architect not less than 21 days' notice of the date on which any Plant or a major item of other Goods will be delivered to the Site;
- b) the Contractor shall be responsible for packing, loading, transporting, receiving, unloading, storing and protecting all Goods and other things required for the Works; and
- c) the Contractor shall indemnify and hold the Procuring Entity harmless against and from all damages, losses and expenses (including legal fees and expenses) resulting from the transport of Goods and shall negotiate and pay all claims arising from their transport.

4.17 Contractor's Equipment

The Contractor shall be responsible for all Contractor's Equipment. When brought on to the Site, Contractor's Equipment shall be deemed to be exclusively intended for the execution of the Works. The Contractor shall not remove from the Site any major items of Contractor's Equipment without the consent of the Engineer. However, consent shall not be required for vehicles transporting Goods or Contractor's Personnel off Site.

4.18 Protection of the Environment

- 4.18.1 The contractor shall comply with the applicable environmental laws, regulations and policies.
- 4.18.2 The Contractor shall take all reasonable steps to protect the environment (both on

and off the Site) and to limit damage and nuisance to people and property resulting from pollution, noise and other results of his operations.

- 4.183 The Contractors shall ensure that emissions, surface charges and effluent from the Contractor's activities shall not exceed the values stated in the Specification or prescribed by applicable Laws.

4.19 Electricity, Water and Gas

- 4.19.1 The Contractor shall, except as stated below, be responsible for the provision of all power, water and other services he may require for his construction activities and to the extent defined in the Specifications, for the tests.

- 4.19.2 The Contractor shall be entitled to use for the purposes of the Works such supplies of electricity, water, gas and other services as may be available on the Site and of which details and prices are given in the Specifications. The Contractor shall, at his risk and cost, provide any apparatus necessary for his use of these services and for measuring the quantities consumed.

- 4.19.3 The quantities consumed and the amounts due (at these prices) for such services shall be agreed or determined by the Architect in accordance with Sub-Clause 2.5 [Procuring Entity's Claims] and Sub-Clause 3.5 [Determinations]. The Contractor shall pay these amounts to the Procuring Entity.

4.20 Procuring Entity's Equipment and Free-Issue Materials

- 4.20.1 The Procuring Entity shall make the Procuring Entity's Equipment (if any) available for the use of the Contractor in the execution of the Works in accordance with the details, arrangements and prices stated in the Specification. Unless otherwise stated in the Specification:

- a) The Procuring Entity shall be responsible for the Procuring Entity's Equipment, except that
- b) the Contractor shall be responsible for each item of Procuring Entity's Equipment whilst any of the Contractor's Personnel is operating it, driving it, directing it or in possession or control of it.

- 4.20.1 The appropriate quantities and the amounts due (at such stated prices) for the use of Procuring Entity's Equipment shall be agreed or determined by the Architect in accordance with Sub-Clause 2.5 [Procuring Entity's Claims] and Sub-Clause 3.5 [Determinations]. The Contractor shall pay these amounts to the Procuring Entity.

- 4.20.2 The Procuring Entity shall supply, free of charge, the "free-issue materials" (if any) in accordance with the details stated in the Specification. The Procuring Entity shall, at his risk and cost, provide these materials at the time and place specified in the Contract. The Contractor shall then visually inspect them and shall promptly give notice to the Architect of any shortage, defect or default in these materials. Unless otherwise agreed by both Parties, the Procuring Entity shall immediately rectify the notified shortage, defect or default.

- 4.20.3 After this visual inspection, the free-issue materials shall come under the care, custody

and control of the Contractor. The Contractor's obligations of inspection, care, custody and control shall not relieve the Procuring Entity of liability for any shortage, defect or default not apparent from a visual inspection.

4.21 Progress Reports

- 4.21.1 Unless otherwise stated in the Special Conditions, monthly progress reports shall be prepared by the Contractor and submitted to the Architect in six copies. The first report shall cover the period up to the end of the first calendar month following the Commencement Date. Reports shall be submitted monthly thereafter, each within 7 days after the last day of the period to which it relates.
- 4.21.2 Reporting shall continue until the Contractor has completed all work which is known to be outstanding at the completion date stated in the Taking-Over Certificate for the Works. Each report shall include:
- a) charts and detailed descriptions of progress, including each stage of design (if any), Contractor's Documents, procurement, manufacture, delivery to Site, construction, erection and testing; and including these stages for work by each nominated Subcontractor (as defined in Clause 5 [NominatedSubcontractors]),
 - b) photographs showing the status of manufacture and of progress on the Site;
 - c) for the manufacture of each main item of Plant and Materials, the name of the manufacturer, manufacture location, percentage progress, and the actual or expected dates of:
 - i) commencement of manufacture,
 - ii) Contractor's inspections,
 - iii) tests, and
 - iv) shipment and arrival at the Site;
 - d) the details described in Sub-Clause 6.10 [Records of Contractor's Personnel and Equipment];
 - e) copies of quality assurance documents, test results and certificates of Materials;
 - f) list of notices given under Sub-Clause 2.5 [Procuring Entity's Claims] and notices given under Sub- Clause 20.1 [Contractor's Claims];
 - g) safety statistics, including details of any hazardous incidents and activities relating to environmental aspects and public relations; and
 - h) comparison so factual and planned progress, with details of any events or circumstances which may jeopardize the completion in accordance with the Contract, and the measures being (or to be) adopted to overcome delays.

4.22 Security of the Site

Unless otherwise stated in the Special Conditions:

- a) The Contractor shall be responsible for keeping unauthorized persons off the Site, and
- b) authorized persons shall be limited to the Contractor's Personnel and the Procuring Entity's Personnel; and to any other personnel notified to the

Contractor, by the Procuring Entity or the Engineer, as authorized personnel of the Procuring Entity's other contractors on the Site.

4.23 Contractor's Operations on Site

4.23.1 The Contractor shall confine his operations to the Site, and to any additional areas which may be obtained by the Contractor and agreed by the Architect as additional working areas. The Contractor shall take all necessary precautions to keep Contractor's Equipment and Contractor's Personnel within the Site and these additional areas, and to keep them off adjacentl and.

4.23.2 During the execution of the Works, the Contractor shall keep the Site free from all unnecessary obstruction and shall store or dispose of any Contractor's Equipment or surplus materials. The Contractor shall clear away and remove from the Site any wreckage, rubbish and Temporary Works which are no longer required.

4.23.3 Upon the issue of a Taking-Over Certificate, the Contractor shall clear away and remove, from that part of the Site and Works to which the Taking-Over Certificate refers, all Contractor's Equipment, surplus material, wreckage, rubbish and Temporary Works. The Contractor shall leave that part of the Site and the Works in a clean and safe condition. However, the Contractor may retain on Site, during the Defects Notification Period, such Goods as are required for the Contractor to fulfil obligations under the Contract.

4.24 Fossils

4.24.1 All fossils, coins, articles of value or antiquity, and structures and other remains or items of geological or archaeological interest found on the Site shall be placed under the care and authority of the Procuring Entity. The Contractor shall take reasonable precautions to prevent Contractor's Personnel or other persons from removing or damaging any of these findings.

4.24.2 The Contractor shall, upon discovery of any such finding, promptly give notice to the Engineer, who shall issue instructions for dealing with it. If the Contractor suffers delay and/or incurs Cost from complying with the instructions, the Contractor shall give a further notice to the Architect and shall be entitled subject to Sub- Clause 20.1 [Contractor's Claims] to:

- a) an extension of time for any such delay, if completion is or will be delayed, under Sub-Clause 8.4 [Extension of Time for Completion], and
- b) payment of any such Cost, which shall be included in the Contract Price.
After receiving this further notice, the Architect shall proceed in accordance with Sub-Clause 3.5 [Determinations] to agree or determine these matters.

5 NOMINATED SUBCONTRACTORS

5.1 Definition of "nominated Subcontractor"

In this Contract, "nominated Subcontractor" means a Subcontractor:

- a) Who is nominated by the Procuring Entity, or
- b) Contractor has nominated as a Subcontractor subject to Sub-Clause 5.2 [Objection to Notification].

5.2 *Objection to Nomination*

The Contractor shall not be under any obligation to employ a nominated Subcontractor against whom the Contractor raises reasonable objection by notice to the Procuring Entity as soon as practicable, with supporting particulars. An objection shall be deemed reasonable if it arises from (among other things) any of the following matters, unless the Procuring Entity agrees in writing to indemnify the Contractor against and from the consequences of the matter:

- a) there are reasons to believe that the Subcontractor does not have sufficient competence, resources or financial strength;
- b) the nominated Subcontractor does not accept to indemnify the Contractor against and from any negligence or misuse of Goods by the nominated Subcontractor, his agents and employees; or
- c) the nominated Subcontractor does not accept to enter into a subcontract which specifies that, for the subcontracted work (including design, if any), the nominated Subcontractor shall:
 - i) undertake to the Contractor such obligations and liabilities as will enable the Contractor to discharge his obligations and liabilities under the Contract;
 - ii) indemnify the Contractor against and from all obligations and liabilities arising under or in connection with the Contract and from the consequences of any failure by the Subcontractor to perform these obligations or to fulfil these liabilities, and
 - iii) be paid only if and when the Contractor has received from the Procuring Entity payments for sums due under the Subcontract referred to under Sub-Clause 5.3 [Payment to nominated Subcontractors].

5.3 *Payments to nominated Subcontractors*

The Contractor shall pay to the nominated Subcontractor the amounts shown on the nominated Subcontractor's invoices approved by the Contractor which the Architect certifies to be due in accordance with the subcontract. These amounts plus other charges shall be included in the Contract Price in accordance with sub-paragraph (b) of Sub-Clause 13.5 [Provisional Sums], except as stated in Sub-Clause 5.4 [Evidence of Payments].

5.4 *Evidence of Payments*

5.4 Before issuing a Payment Certificate which includes an amount payable to a nominated Subcontractor, the Architect may request the Contractor to supply reasonable evidence that the nominated Subcontractor has received all amounts due in accordance with previous Payment Certificates, less applicable deductions for retention or otherwise. Unless the Contractor:

- (a) Submits this reasonable evidence to the Engineer, or
- (b)
 - i) Satisfies the Architect in writing that the Contractor is reasonably entitled to withhold or refuse to pay these amounts, and
 - ii) Submits to the Architect reasonable evidence that the nominated Subcontractor has been notified of the Contractor's entitlement, then the Procuring Entity may (at his sole discretion) pay, directly to the nominated Subcontractor, part or all of such amounts previously certified (less applicable deductions) as are due to the nominated Subcontractor and for which the Contractor has failed to submit the evidence described in sub-

paragraphs (a) or (b) above. The Contractor shall then repay, to the Procuring Entity, the amount which the nominated Subcontractor was directly paid by the Procuring Entity.

6 STAFF AND LABOR

6.1 Engagement of Staff and Labor

Except as otherwise stated in the Specification, the Contractor shall make arrangements for the engagement of all staff and labor, local or otherwise, and for their payment, feeding, transport, and, when appropriate, housing. The Contractor is encouraged, to the extent practicable and reasonable, to employ staff and labor with appropriate qualifications and experience from sources within Kenya.

6.2 Rates of Wages and Conditions of Labor

6.21 The Contractor shall pay rates of wages, and observe conditions of labor, which are not lower than those established for the trade or industry where the work is carried out. If no established rates or conditions are applicable, the Contractor shall pay rates of wages and observe conditions which are not lower than the general level of wages and conditions observed locally by Procuring Entity's whose trade or industry is similar to that of the Contractor.

6.22 The Contractor shall inform the Contractor's Personnel about their liability to pay personal income taxes in Kenya in respect of such of their salaries, wages, allowances and any benefits as are subject to tax under the Laws of Kenya for the time being in force, and the Contractor shall perform such duties in regard to such deductions there of as may be imposed on him by such Laws.

6.3 Persons in the Service of Procuring Entity

The Contractor shall not recruit, or attempt to recruit, staff and labour from amongst the Procuring Entity's Personnel.

6.4 Lab or Laws

The Contractor shall comply with all the relevant labour Laws applicable to the Contractor's Personnel, including Laws relating to their employment, employment of children, health, safety, welfare, immigration and emigration, and shall allow them all their legal rights. The Contractor shall require his employees to obey all applicable Laws, including those concerning safety at work.

6.5 Working Hours

Nowork shall be carried out on the Site on locally recognized days of rest, or outside the normal working hours stated in the **Special Conditions of Contract**, unless:

- a) Otherwise stated in the Contract,
- b) The Architect gives consent, or
- c) The work is unavoidable, or necessary for the protection of life or property or for the safety of the Works, in which case the Contractor shall immediately advise the Engineer, provided that work done outside the normal working hours shall be considered and paid for as overtime.

6.6 *Facilities for Staff and Labor*

Except as otherwise stated in the Specification, the Contractor shall provide and maintain all necessary accommodation and welfare facilities on site for the Contractor's Personnel. The Contractor shall also provide facilities for the Procuring Entity's Personnel as stated in the Specifications. The Contractor shall not permit any of the Contractor's Personnel to maintain any temporary or permanent living quarters within the structures forming part of the Permanent Works.

6.7 *Health and Safety*

- 671 The Contractor shall at all times take all reasonable precautions to maintain the health and safety of the Contractor's Personnel. In collaboration with local health authorities, the Contractor shall ensure that medical staff, first aid facilities, sick bay and ambulance service are available at all times at the Site and at any accommodation for Contractor's and Procuring Entity's Personnel, and that suitable arrangements are made for all necessary welfare and hygiene requirements and for the prevention of epidemics.
- 672 The Contractor shall appoint an accident prevention officer at the Site, responsible for maintaining safety and protection against accidents. This person shall be qualified for this responsibility and shall have the authority to issue instructions and take protective measures to prevent accidents. Throughout the execution of the Works, the Contractor shall provide what ever is required by this person to exercise this responsibility and authority.
- 673 The Contractor shall send, to the Engineer, details of any accident as soon as practicable after its occurrence. The Contractor shall maintain records and make reports concerning health, safety and welfare of persons, and damage to property, as the Architect may reasonably require.
- 674 The Contractor shall conduct an awareness programme on HIV and other sexually transmitted diseases via an approved service provider and shall undertake such other measures taken to reduce the risk of the transfer of these diseases between and among the Contractor's Personnel and the local community, to promote early diagnosis and to assist affected individuals.

6.8 *Contractor's Superintendence*

- 681 Throughout the execution of the Works, and as long thereafter as is necessary to fulfil the Contractor's obligations, the Contractor shall provide all necessary superintendence to plan, arrange, direct, manage, inspect and test the work.
- 682 Superintendence shall be given by a sufficient number of persons having adequate knowledge of the language for communications (defined in Sub-Clause 1.4 [Law and Language]) and of the operations to be carried out (including the methods and techniques required, the hazards likely to be encountered and methods of preventing accidents), for the satisfactory and safe execution of the Works.

6.9 *Contractor's Personnel*

- 691 The Contractor's Personnel shall be appropriately qualified, skilled and experienced in their respective trades or occupations. The Contractor's Key personnel shall be named in the Special Conditions of Contract. The Architect may require the

Contractor to remove (or cause to be removed) any person employed on the Site or Works, including the Contractor's Representative if applicable, who:

- a) Persists in any misconduct or lack of care,
- b) Carries out duties in competently or negligently,
- c) fails to conform with any provisions of the Contract,
- d) persists in any conduct which is prejudicial to safety, health, or the protection of the environment, or
- e) based on reasonable evidence, is determined to have engaged in Fraud and Corruption during the execution of the Works.

6.9.2 If appropriate, the Contractor shall then appoint (or cause to be appointed) a suitable replacement person.

6.10 *Records of Contractor's Personnel and Equipment*

The Contractor shall submit, to the Engineer, details showing the number of each class of Contractor's Personnel and of each type of Contractor's Equipment on the Site. Details shall be submitted each calendar month, in a form approved by the Engineer, until the Contractor has completed all work which is known to be outstanding at the completion date stated in the Taking-Over Certificate for the Works.

6.11 *Disorderly Conduct*

The Contractor shall at all times take all reasonable precautions to prevent any unlawful, riotous or disorderly conduct by or amongst the Contractor's Personnel, and to preserve peace and protection of persons and property on and near the Site.

6.12 *Foreign Personnel*

6.12.1 The Contractor shall not employ foreign personnel unless the contractor demonstrates that there are no Kenyans with the required skills.

6.12.2 The Contractor shall be responsible for the return of any foreign personnel to the place where they were recruited or to their domicile. In the event of the death in Kenya of any of these personnel or members of their families, the Contractor shall similarly be responsible for making the appropriate arrangements for their return or burial.

6.13 *Supply of Water*

The Contractor shall, having regard to local conditions, provide on the Site an adequate supply of drinking and other water for the use of the Contractor's Personnel.

6.14 *Measures against Insect and Pest Nuisance*

The Contractor shall at all times take the necessary precautions to protect the Contractor's Personnel employed on the Site from insect and pest nuisance, and to reduce the danger to their health. The Contractor shall comply with all the regulations of the local health authorities, including use of appropriate insecticide.

6.15 *Alcoholic Liquor or Drugs*

The Contractor shall not, otherwise than in accordance with the Laws of Kenya, onsite, import, sell, give, barter or otherwise dispose of any alcoholic liquor or drugs, or permit or allow importation, sale, gift, barter or disposal there of by Contractor's Personnel.

6.16 *Prohibition of Forced or Compulsory Labour*

The Contractor shall not employ forced labor, which consists of any work or service, not voluntarily performed, that is exacted from an individual under threat of force or penalty, and includes any kind of involuntary or compulsory labor, such as indentured labor, bonded labor or similar labor-contracting arrangements.

6.17 *Prohibition of Harmful Child Labor*

The Contractor shall not employ children in a manner that is economically exploitative, or is likely to be hazardous, or to interfere with, the child's education, or to be harmful to the child's health or physical, mental, spiritual, moral, or social development. Where the relevant labour laws of Kenya have provisions for employment of minors, the Contractor shall follow those laws applicable to the Contractor. Children below the age of 18 years shall not be employed in dangerous work.

6.18 *Employment Records of Workers*

The Contractor shall keep complete and accurate records of the employment of labour at the Site. The records shall include the names, ages, genders, hours worked and wages paid to all workers. These records shall be summarized on a monthly basis and submitted to the Engineer. These records shall be included in the details to be submitted by the Contractor under Sub-Clause 6.10 [Records of Contractor's Personnel and Equipment].

6.19 *Workers' Organizations*

The Contractor shall comply with the relevant labor laws that recognize workers' rights to form and to join workers' organizations of their choosing without interference.

6.20 *Non-Discrimination and Equal Opportunity*

The Contractor shall base the labour employment on the principle of equal opportunity and fair treatment and shall not discriminate with respect to aspects of the employment relationship, including recruitment and hiring, compensation (including wages and benefits), working conditions and terms of employment, access to training, promotion, termination of employ mentor retirement, and discipline.

7 *PLANT, MATERIALS AND WORKMANSHIP*

7.1 **Manner of Execution**

The Contractor shall carry out the manufacture/assemble of plant, the production and manufacture of Materials, and all other execution of the Works:

- a) In the manner (if any) specified in the Contract,

- b) in a proper workman like and careful manner, in accordance with recognized good practice, and
- c) with properly equipped facilities and non-hazardous Materials, except as otherwise specified in the Contract.

7.2 *Samples*

The Contractor shall submit the following samples of Materials, and relevant information, to the Architect for consent prior to using the Material sin or for the Works:

- a) manufacturer's standard samples of Materials and samples specified in the Contract, all at the Contractor's cost, and
- b) additional samples instructed by the Architect as a Variation.

Each sample shall be labeled as to origin and intended use in the Works.

7.3 *Inspection*

7.3.1 The Procuring Entity's Personnel shall at all reasonable times:

- a) Have full access to all parts of the Site and to all places from which natural Materials are being obtained, and
- b) during production, manufacture and construction (at the Site and elsewhere), be entitled to examine, inspect, measure and test the materials and workmanship, and to check the progress of manufacture of Plant and production and manufacture of Materials.

7.3.2 The Contractor shall give the Procuring Entity's Personnel full opportunity to carry out these activities, including providing access, facilities, permissions and safety equipment. No such activity shall relieve the Contractor from any obligation or responsibility.

7.3.3 The Contractor shall give notice to the Architect whenever any work is ready and before it is covered up, put out of sight, or packaged for storage or transport. The Architect shall then either carry out the examination, inspection, measurement or testing without unreasonable delay, or promptly give notice to the Contractor that the Architect does not require to do so. If the Contractor fails to give the notice, he shall, if and when required by the Engineer, uncover the work and there after reinstate and make good, all at the Contractor's cost.

7.4 *Testing*

7.4.1 This Sub-Clause shall apply to all tests specified in the Contract.

7.4.2 Except as otherwise specified in the Contract, the Contractor shall provide all apparatus, assistance, documents and other information, electricity, equipment, fuel, consumables, instruments, labor, materials, and suitably qualified and experienced staff, as are necessary to carry out the specified tests efficiently. The Contractor shall agree, with the Engineer, the time and place or he specified testing of any Plant, Materials and other parts of the Works.

7.4.3 The Architect may, under Clause 13 [Variations and Adjustments], vary the location or details of specified tests, or instruct the Contractor to carry out additional tests. If

these varied or additional tests show that the tested Plant, Materials or workmanship is not in accordance with the Contract, the cost of carrying out this Variation shall be borne by the Contractor, notwithstanding other provisions of the Contract.

7.4.4 The Architect shall give the Contractor not less than 24 hours' notice of the Architect intention to attend the tests. If the Architect does not attend at the time and place agreed, the Contractor may proceed with the tests, unless otherwise instructed by the Engineer, and the tests shall then be deemed to have been made in the Architect presence.

7.4.5 If the Contractor suffers delay and/ or incurs Cost from complying with these instructions or as a result of a delay for which the Procuring Entity is responsible, the Contractor shall give notice to the Architect and shall be entitled subject to Sub-Clause 20.1 [Contractor's Claims] to:

- a) an extension of time for any such delay, if completion is or will be delayed, under Sub-Clause 8.4 [Extension of Time for Completion], and
- b) payment of any such Cost-plus profit, which shall be included in the Contract Price.

7.4.6 After receiving this notice, the Architect shall proceed in accordance with Sub-Clause 3.5 [Determinations] to agree or determine these matters.

7.4.7 The Contractor shall promptly forward to the Architect duly certified reports of the tests. When the specified tests have been passed, the Architect shall endorse the Contractor's test certificate, or issue a certificate to him, to that effect. If the Architect has not attended the tests, he shall be deemed to have accepted the readings as accurate.

7.5 *Rejection*

7.5.1 If, as a result of an examination, inspection, measurement or testing, any Plant, Materials or workmanship is found to be defective or otherwise not in accordance with the Contract, the Architect may reject the Plant, Materials or workmanship by giving notice to the Contractor, with reasons. The Contractor shall then promptly make good the defect and ensure that the rejected item complies with the Contract.

7.5.2 If the Architect requires this Plant, Materials or workmanship to be retested, the tests shall be repeated under the same terms and conditions. If the rejection and retesting cause the Procuring Entity to incur additional costs, the Contractor shall subject to Sub-Clause 2.5 [Procuring Entity's Claims] pay these costs to the Procuring Entity.

7.6 *Remedial Work*

7.6.1 Notwithstanding any previous test or certification, the Architect may instruct the Contractor to:

- a) Remove from the Site and replace any Plant or Materials which is not in accordance with the Contract,
- b) remove and re-execute any other work which is not in accordance with the Contract, and
- c) execute any work which is urgently required for the safety of the Works, whether because of an accident, unforeseen event or otherwise.

7.6.2 The Contractor shall comply with the instruction within a reasonable time, which

shall be the time (if any) specified in the instruction, or immediately if urgency is specified under sub-paragraph (c).

7.63 If the Contractor fails to comply with the instruction, the Procuring Entity shall be entitled to employ and pay other persons to carry out the work. Except to the extent that the Contractor would have been entitled to payment for the work, the Contractor shall subject to Sub-Clause 2.5 [Procuring Entity's Claims] pay to the Procuring Entity all costs arising from this failure.

7.64 If the contractor repeatedly delivers defective work, the Procuring Entity may consider termination in accordance with Clause 15.

7.7 Ownership of Plant and Materials

Except as otherwise provided in the Contract, each item of Plant and Materials shall become the property of the Procuring Entity at whichever is the earlier of the following times, free from liens and other encumbrances:

- a) When it is incorporated in the Works;
- b) when the Contractor is paid the corresponding value of the Plant and Materials under Sub-Clause 8.10 [Payment for Plant and Materials in Event of Suspension].

7.8 Royalties

Unless otherwise stated in the Specification, the Contractor shall pay all royalties, rents and other payments for:

- a) Natural materials obtained from outside the Site, and
- b) the disposal of material from demolitions and excavations and of other surplus material (whether natural or man-made), except to the extent that disposal as within the Site are specified in the Contract.

8 COMMENCEMENT, DELAYS AND SUSPENSION

8.1 Commencement of Works

8.1.1 Except as otherwise specified in the Special Conditions of Contract, the Commencement Date shall be the date at which the following precedent conditions have all been fulfilled and the Architect notification recording the agreement of both Parties on such fulfilment and instructing to commence the Work is received by the Contractor:

- a) Signature of the Contract Agreement by both Parties, and if required, approval of the Contract by relevant authorities of Kenya;
- b) except if otherwise specified in the Special Conditions of Contract, effective access to and possession of the Site given to the Contractor together with such permission(s) under (a) of Sub-Clause 1.13 [Compliance with Laws] as required for the commencement of the Works.
- c) Receipt by the Contractor of the Advance Payment under Sub-Clause 14.2 [Advance Payment] provided that the corresponding bank guarantee has been delivered by the Contractor.

8.1.2 If the said Architect instruction is not received by the Contractor within 180 days

from his receipt of the Letter of Acceptance, the Contractor shall be entitled to terminate the Contract under Sub-Clause 6.2 [Termination by Contractor].

8.13 The Contractor shall commence the execution of the Works as soon as is reasonably practicable after the Commencement Date and shall then proceed with the Works with due expedition and without delay.

8.2 Time for Completion

The Contractor shall complete the whole of the Works, and each Section (if any), within the Time for Completion for the Works or Section (as the case may be), including:

- a) Achieving the passing of the Test on Completion, and
- b) completing all work which is stated in the Contract as being required for the Works or Section to be considered to be completed for the purposes of taking-over under Sub-Clause 10.1 [Taking Over of the Works and Sections].

8.3 Programme

8.31 The Contractor shall submit a detailed time programme to the Architect within 4 days after receiving the notice under Sub-Clause 8.1 [Commencement of Works]. The Contractor shall also submit a revised programme whenever the previous programme is inconsistent with actual progress or with the Contractor's obligations. Each programme shall include:

- a) The order in which the Contractor intends to carry out the Works, including the anticipated timing of each stage of design (if any), Contractor's Documents, procurement, manufacture of Plant, delivery to Site, construction, erection and testing,
- b) each of these stages for work by each nominated Subcontractor (as defined in Clause 5 [Nominated Subcontractors]),
- c) the sequence and timing of inspections and tests specified in the Contract, and
- d) a supporting report which includes:
 - i) a general description of the methods which the Contractor intends to adopt, and of the major stages, in the execution of the Works, and
 - ii) details showing the Contractor's reasonable estimate of the number of each class of Contractor's Personnel and of each type of Contractor's Equipment, required on the Site for each major stage.

8.32 Unless the Engineer, within 14 days after receiving a programme, gives notice to the Contractor stating the extent to which it does not comply with the Contract, the Contractor shall proceed in accordance with the programme, subject to his other obligations under the Contract. The Procuring Entity's Personnel shall be entitled to rely upon the programme when planning their activities.

8.33 The Contractor shall promptly give notice to the Architect of specific probable future events or circumstances which may adversely affect the work, increase the Contract Price or delay the execution of the Works.

8.34 If, at anytime, the Architect gives notice to the Contractor that a programme fails (to the extent stated) to comply with the Contractor to be consistent with actual progress and the Contractor's stated intentions, the Contractor shall submit a revised

programme to the Architect in accordance with this Sub-Clause.

8.4 *Extension of Time for Completion*

- 84.1 The Contractor shall be entitled subject to Sub-Clause 20.1 [Contractor's Claims] to an extension of the Time for Completion if and to the extent that completion for the purposes of Sub-Clause 10.1 [Taking Over of the Works and Sections] is or will be delayed by any of the following causes:
- a) a Variation (unless an adjustment to the Time for Completion has been agreed under Sub-Clause 13.3 [Variation Procedure]) or other substantial change in the quantity of an item of work included in the Contract,
 - b) a cause of delay giving an entitlement to extension of time under a Sub-Clause of these Conditions,
 - c) exceptionally adverse climatic conditions,
 - d) Unforeseeable shortages in the availability of personnel or Goods caused by epidemic or governmental actions, or
 - e) any delay, impediment or prevention caused by or attributable to the Procuring Entity, the Procuring Entity's Personnel, or the Procuring Entity's other contractors.
- 84.2 If the Contractor considers itself to be entitled to an extension of the Time for Completion, the Contractor shall give notice to the Architect in accordance with Sub-Clause 20.1 [Contractor's Claims]. When determining each extension of time under Sub-Clause 20.1, the Architect shall review previous determinations and may increase, but shall not decrease, the total extension of time.

8.5 *Delays Caused by Authorities*

If the following conditions apply, namely:

- a) The Contractor has diligently followed the procedures laid down by the relevant legally constituted public authorities in Kenya,
- b) These authorities delay or disrupt the Contractor's work, and
- c) the delay or disruption was Unforeseeable, then this delay or disruption will be considered as a cause of delay under sub-paragraph (b) of Sub-Clause 8.4 [Extension of Time for Completion].

8.6 *Rate of Progress*

- 8.61 If, at anytime:
- a) Actual progress is too slow to complete within the Time for Completion, and/or
 - b) Progress has fallen (or will fall) behind the current programme under Sub-Clause 8.3 [Programme], other than as a result of a cause listed in Sub-Clause 8.4 [Extension of Time for Completion], then the Architect may instruct the Contractor to submit, under Sub-Clause 8.3 [Programme], a revised programme and supporting report describing the revised methods which the Contractor proposes to adopt in order to expedite progress and complete within the Time for Completion.
- 8.62 Unless the Architect notifies otherwise, the Contractor shall adopt these revised methods, which may require increases in the working hours and/or in the numbers of Contractor's Personnel and/or Goods, at the risk and cost of the Contractor. If these revised methods cause the Procuring Entity to incur additional costs, the Contractor shall subject to notice under Sub-Clause 2.5 [Procuring Entity's Claims] pay these costs to the Procuring Entity, in addition to delay damages (if any) under Sub-Clause 8.7 below.
- 8.63 Additional costs of revised methods including acceleration measures, instructed by the Architect to reduce delays resulting from causes listed under Sub-Clause 8.4 [Extension of Time for Completion] shall be paid by the Procuring Entity, without generating, however, any other additional payment benefit to the Contractor.

8.7 *Delay Damages*

- 8.7.1 If the Contractor fails to comply with Sub-Clause 8.2 [Time for Completion], the Contractor shall subject to notice under Sub-Clause 2.5 [Procuring Entity's Claims] pay delay damages to the Procuring Entity for this default. These delay damages shall be the sum stated in the **Special Conditions of Contract**, which shall be paid for everyday which shall elapse between the relevant Time for Completion and the date stated in the taking-Over Certificate. However, the total amount due under this Sub-Clause shall not exceed the maximum amount of delay damages (if any) stated in the Special Conditions of Contract.
- 8.7.2 These delay damages shall be the only damages due from the Contractor for such default, other than in the event of termination under Sub-Clause 15.2 [Termination by Procuring Entity] prior to completion of the Works. These damages shall not relieve the Contractor from his obligation to complete the Works, or from any other duties, obligations or responsibilities which he may have under the Contract.

8.8 *Suspension of Work*

- 8.8.1 The Architect may at anytime instruct the Contractor to suspend progress of part or all of the Works. During such suspension, the Contractor shall protect, store and secure such part or the Works against any deterioration, loss or damage.
- 8.8.2 The Architect may also notify the cause for the suspension. If and to the extent that the cause is notified and is the responsibility of the Contractor, the following Sub-Clauses 8.9, 8.10 and 8.11 shall not apply.

8.9 *Consequences of Suspension*

- 891 If the Contractor suffers delay and/or incurs Cost from complying with the Architect instructions under Sub-Clause 8.8 [Suspension of Work] and/or from resuming the work, the Contractor shall give notice to the Architect and shall be entitled subject to Sub-Clause 20.1 [Contractor's Claims] to:
- a) an extension of time for any such delay, if completion is or will be delayed, under Sub-Clause 8.4 [Extension of Time for Completion], and
 - b) Payment of any such Cost, which shall be included in the Contract Price.
- 892 After receiving this notice, the Architect shall proceed in accordance with Sub-Clause 3.5 [Determinations] to agree or determine these matters.
- 893 The Contractor shall not be entitled to an extension of time for, or to payment of the Cost incurred in, making good the consequences of the Contractor's faulty design, workmanship or materials, or of the Contractor's failure to protect, store or secure in accordance with Sub-Clause 8.8 [Suspension of Work].

8.10 *Payment for Plant and Materials in Event of Suspension*

The Contractor shall be entitled to payment of the value (as at the date of suspension) of Plant and/ or Materials which have not been delivered to Site, if:

- a) The work on Plant or delivery of Plant and/ or Materials has been suspended for more than 30 days, and
- b) the Contractor has marked the Plant and/or Materials as the Procuring Entity's property in accordance with the Architect instructions.

8.11 *Prolonged Suspension*

If the suspension under Sub-Clause 8.8 [Suspension of Work] has continued for more than 84 days, the Contractor may request the Architect permission to proceed. If the Architect does not give permission within 30 days after being requested to do so, the Contractor may, by giving notice to the Engineer, treat the suspension as an omission under Clause 13 [Variations and Adjustments] of the affected part of the Works. If the suspension affects the whole of the Works, the Contractor may give notice of termination under Sub-Clause 16.2 [Termination by Contractor].

8.12 *Resumption of Work*

After the permission or instruction to proceed is given, the Contractor and the Architect shall jointly examine the Works and the Plant and Materials affected by the suspension. The Contractor shall make good any deterioration or defect in or loss of the Works or Plant or Materials, which has occurred during the suspension after receiving from the Architect an instruction to this effect under Clause 13 [Variations and Adjustments].

9 *TESTS ON COMPLETION*

9.1 *Contractor's Obligations*

- 9.1 The Contractor shall carry out the Tests on Completion in accordance with this Clause and Sub-Clause 7.4 [Testing], after providing the documents in accordance with sub-

paragraph (d) of Sub-Clause 4.1 [Contractor's General Obligations].

9.1.2 The Contractor shall give to the Architect not less than 21 days' notice of the date after which the Contractor will be ready to carry out each of the Tests on Completion. Unless otherwise agreed, Tests on Completion shall be carried out within 14 days after this date, on such day or days as the Architect shall instruct.

9.1.3 In considering the results of the Tests on Completion, the Architect shall make allowances for the effect of any use of the Works by the Procuring Entity on the performance or other characteristics of the Works. As soon as the Works, or a Section, have passed any Tests on Completion, the Contractor shall submit a certified report of the results of these Tests to the Engineer.

9.2 *Delayed Tests*

9.2.1 If the Tests on Completion are being unduly delayed by the Procuring Entity, Sub-Clause 7.4 [Testing] (fifth paragraph) and/ or Sub-Clause 10.3 [Interference with Tests on Completion] shall be applicable.

9.2.2 If the Tests on Completion are being unduly delayed by the Contractor, the Architect may by notice require the Contractor to carry out the Tests within 21 days after receiving the notice. The Contractor shall carry out the Tests on such day or days within that period as the Contractor may fix and of which he shall give notice to the Engineer.

9.2.3 If the Contractor fails to carry out the Tests on Completion within the period of 21 days, the Procuring Entity's Personnel may proceed with the Test at the risk and cost of the Contractor. The Tests on Completion shall then be deemed to have been carried out in the presence of the Contractor and the results of the Tests shall be accepted as accurate.

9.3 *Retesting of related works*

If the Works, or a Section, fail to pass the Tests on Completion, Sub-Clause 7.5 [Rejection] shall apply, and the Architect or the Contractor may require the failed Tests, and Tests on Completion on any related work, to be repeated under the same terms and conditions.

9.4 *Failure to Pass Tests on Completion*

9.4.1 If the Works, or a Section, fail to pass the Tests on Completion repeated under Sub-Clause 9.3 [Retesting], the Architect shall be entitled to:

- a) Order further repetition of Tests on Completion under Sub-Clause 9.3; or
- b) if the failure deprives the Procuring Entity of substantially the whole benefit of the Works or Section, reject the Works or Section (as the case may be), in which event the Procuring Entity shall have the same remedies as are provided in subparagraph (c) of Sub-Clause 11.4 [Failure to Remedy Defects].

10 *PROCURING ENTITY'S TAKING OVER*

10.1 *Taking Over of the Works and Sections*

10.1.1 Except as stated in Sub-Clause 9.4 [Failure to Pass Tests on Completion], the Works

shall be taken over by the Procuring Entity when (i) the Works have been completed in accordance with the Contract, including the matters described in Sub-Clause 8.2 [Time for Completion] and except as allowed in sub-paragraph (a) below, and (ii) a Taking-Over Certificate for the Works has been issued, or is deemed to have been issued in accordance with this Sub-Clause.

10.12 The Contractor may apply by notice to the Architect for a Taking-Over Certificate not earlier than 14 days before the Works will, in the Contractor's opinion, be complete and ready for taking over. If the Works are divided into Sections, the Contractor may similarly apply for a Taking-Over Certificate for each Section.

10.13 The Architect shall, within 30 days after receiving the Contractor's application:

- a) Issue the Taking-Over Certificate to the Contractor, stating the date on which the Works or Section were completed in accordance with the Contract, except for any minor outstanding work and defects which will not substantially affect the use of the Works or Section for their intended purpose (either until or whilst this work is completed and these defects are remedied); or
- b) reject the application, giving reasons and specifying the work required to be done by the Contractor to enable the Taking-Over Certificate to be issued. The Contractor shall then complete this work before issuing a further notice under this Sub-Clause.

10.14 If the Architect fails either to issue the Taking-Over Certificate or to reject the Contractor's application within the period of 30 days, and if the Works or Section (as the case may be) are substantially in accordance with the Contract, the Taking-Over Certificate shall be deemed to have been issued on the last day of that period.

10.2 Taking Over of Parts of the Works

10.21 The Architect may, at the sole discretion of the Procuring Entity, issue a Taking-Over Certificate for any part of the Permanent Works.

10.22 The Procuring Entity shall not use any part of the Works (other than as a temporary measure which is either specified in the Contract or agreed by both Parties) unless and until the Architect has issued a Taking-Over Certificate for this part. However, if the Procuring Entity does use any part of the Works before the Taking-Over Certificate is issued:

- a) The part which is used shall be deemed to have been taken over as from the date on which it is used,
- b) the Contractor shall cease to be liable for the care of such part as from this date, when responsibility shall pass to the Procuring Entity, and
- c) if requested by the Contractor, the Architect shall issue a Taking-Over Certificate for this part.

10.23 After the Architect has issued a Taking-Over Certificate for a part of the Works, the Contractor shall be given the earliest opportunity to take such steps as may be necessary to carry out any outstanding Tests on Completion. The Contractor shall carry out these Tests on Completion as soon as practicable before the expiry date of the relevant Defects Notification Period.

10.24 If the Contractor incurs Cost as a result of the Procuring Entity taking over and/or using a part of the Works, other than such use as is specified in the Contract agreed by the Contractor, the Contractor shall (i) give notice to the Architect and (ii) be

entitled subject to Sub-Clause 20.1 [Contractor's Claims] to payment of any such accrued costs, which shall be included in the Contract Price. After receiving this notice, the Architect shall proceed in accordance with Sub-Clause 3.5 [Determinations] to agree or determine this accrued cost.

10.25 If a Taking-Over Certificate has been issued for a part of the Works (other than a Section), the delay damages there after for completion of the remainder of the Works shall be reduced. Similarly, the delay damages for the remainder of the Section (if any) in which this part is included shall also be reduced. For any period of delay after the date stated in this Taking-Over Certificate, the proportional reduction in these delay damages shall be calculated as the proportion which the value of the part so certified bears to the value of the Works or Section (as the case may be) as a whole. The Architect shall proceed in accordance with Sub-Clause 3.5 [Determinations] to agree or determine these proportions. The provisions of this paragraph shall only apply to the daily rate of delay damages under Sub-Clause 8.7 [Delay Damages] and shall not affect the maximum amount of these damages.

10.3 *Interference with Tests on Completion*

10.31 If the Contractor is prevented, for more than 14 days, from carrying out the Tests on Completion by a cause for which the Procuring Entity is responsible, the Procuring Entity shall be deemed to have taken over the Works or Section (as the case may be) on the date when the Tests on Completion would otherwise have been completed.

10.32 The Architect shall then issue a Taking-Over Certificate accordingly, and the Contractor shall carry out the Tests on Completion as soon as practicable, before the expiry date of the Defects Notification Period. The Architect shall require the Tests on Completion to be carried out by giving 14 days' notice and in accordance with the relevant provisions of the Contract.

10.33 If the Contractor suffers delay and/or incurs Cost as a result of this delay in carrying out the Tests on Completion, the Contractor shall give notice to the Architect and shall be entitled subject to Sub-Clause 20.1 [Contractor's Claims] to:

- a) an extension of time for any such delay, if completion is or will be delayed, under Sub-Clause 8.4 [Extension of Time for Completion], and
- b) payment of any such accrued costs, which shall be included in the Contract Price.

10.34 After receiving this notice, the Architect shall proceed in accordance with Sub-Clause 3.5 [Determinations] to agree or determine these matters.

10.4 *Surfaces Requiring Reinstatement*

Except as otherwise stated in a Taking-Over Certificate, a certificate for a Section or part of the Works shall not be deemed to certify completion of any ground or other surfaces requiring reinstatement.

11 *DEFECTS LIABILITY*

11.1 *Completion of Outstanding Work and Remedying Defects*

11.1 In order that the Works and Contractor's Documents, and each Section, shall be in the condition required by the Contract (fairwear and tear excepted) by the expiry

date of the relevant Defects Notification Period or as soon as practicable there after, the Contractor shall:

- a) complete any work which is outstanding on the date stated in a Taking-Over Certificate, within such reasonable time as is instructed by the Engineer, and
- b) execute all work required to remedy defects or damage, as may be notified by (or on behalf of) the Procuring Entity on or before the expiry date of the Defects Notification Period for the Works or Section (as the case may be).

11.2 If a defect appears or damage occurs, the Contractor shall be notified accordingly by the Engineer.

11.2 Cost of Remedying Defects

11.21 All work referred to in sub-paragraph (b) of Sub-Clause 11.1 [Completion of Outstanding Work and Remedying Defects] shall be executed at the risk and cost of the Contractor, if and to the extent that the work is attributable to:

- a) Any design for which the Contractor is responsible,
- b) Plant, Materials or workmanship not being in accordance with the Contract, or
- c) Failure by the Contractor to comply with any other obligation.

11.22 If and to the extent that such work is attributable to any other cause, the Contractor shall be notified promptly by (or on behalf of) the Procuring Entity, and Sub-Clause 13.3 [Variation Procedure] shall apply.

11.3 Extension of Defects Notification Period

11.31 The Procuring Entity shall be entitled subject to Sub-Clause 2.5 [Procuring Entity's Claims] to an extension of the Defects Notification Period for the Works or a Section if and to the extent that the Works, Section or a major item of Plant (as the case may be, and after taking over) cannot be used for the purposes for which they are intended by reason of a defect or by reason of damage attributable to the Contractor. However, a Defects Notification Period shall not be extended by more than two years.

11.32 If delivery and/ or erection of Plant and/ or Materials was suspended under Sub-Clause 8.8 [Suspension of Work] or Sub-Clause 16.1 [Contractor's Entitlement to Suspend Work], the Contractor's obligations under this Clause shall not apply to any defects or damage occurring more than two years after the Defects Notification Period for the Plant and/ or Materials would otherwise have expired.

11.4 Failure to Remedy Defects

11.41 If the Contractor fails to remedy any defect or damage within a reasonable time, a date may be fixed by the Engineer, on or by which the defect or damage is to be remedied. The Contractor shall be given reasonable notice of this date.

11.42 If the Contractor fails to remedy the defect or damage by this notified date and this remedial work was to be executed at the cost of the Contractor under Sub-Clause 11.2 [Cost of Remedying Defects], the Procuring Entity may (at his option):

- (a) Carry out the work itself or by others, in a reasonable manner and at the Contractor's cost, but the Contractor shall have no responsibility for this work; and the Contractor shall subject to Sub-Clause 2.5 [Procuring Entity's Claims] pay to the Procuring Entity the costs reasonably incurred by the Procuring Entity in remedying the defect or damage;

- (b) Require the Architect to agree or determine a reasonable reduction in the Contract Price in accordance with Sub-Clause 3.5 [Determinations]; or
- (c) if the defect or damage deprives the Procuring Entity of substantially the whole benefit of the Works or any major part of the Works, terminate the Contract as a whole, or in respect of such major part which cannot be put to the intended use. Without prejudice to any other rights, under the Contract otherwise, the Procuring Entity shall then be entitled to recover all sums paid for the Works or for such part (as the case may be), plus financing costs and the cost of dismantling the same, clearing the Site and returning Plant and Materials to the Contractor.

11.5 *Removal of Defective Work*

If the defect or damage cannot be remedied expeditiously on the Site and the Procuring Entity gives consent, the Contractor may remove from the Site for the purposes of repair such items of Plant as are defective or damaged. This consent may require the Contractor to increase the amount of the Performance Security by the full replacement cost of these items, or to provide other appropriate security.

11.6 *Further Tests*

11.61 If the work of remedying of any defect or damage may affect the performance of the Works, the Architect may require the repetition of any of the tests described in the Contract. The requirement shall be made by notice within 14 days after the defect or damage is remedied.

11.62 These tests shall be carried out in accordance with the terms applicable to the previous tests, except that they shall be carried out at the risk and cost of the Party liable, under Sub-Clause 11.2 [Cost of Remedying Defects], for the cost of the remedial work.

11.7 *Right of Access*

Until the Completion Certificate has been issued, the Contractor shall have such right of access to the Works as is reasonably required in order to comply with this Clause, except as may be inconsistent with the Procuring Entity's reasonable security restrictions.

11.8 *Contractor to Search*

The Contractor shall, if required by the Engineer, search for the cause of any defect on parts of the works that have already been accepted, under the direction of the Engineer. Unless the defect is to be remedied at the cost of the Contractor under Sub-Clause 11.2 [Cost of Remedying Defects], the Cost of the search plus profit shall be agreed or determined by the Architect in accordance with Sub-Clause 3.5 [Determinations] and shall be included in the Contract Price.

11.9 *Completion Certificate*

11.91 Performance of the Contractor's obligations shall not be considered to have been completed until the Architect has issued the Completion Certificate to the Contractor, stating the date on which the Contractor completed his obligations under the Contract.

- 1192 The Architect shall issue the Completion Certificate within 30 days after the latest of the expiry dates of the Defects Liability Period, or as soon thereafter as the Contractor has supplied all the Contractor's Documents and completed and tested all the Works, including remedying any defects. A copy of the Completion Certificate shall be issued to the Procuring Entity.
- 1193 Only the Completion Certificate shall be deemed to constitute acceptance of the Works.

11.10 Unfulfilled Obligations

After the Completion Certificate has been issued, each Party shall remain liable for the fulfilment of any obligation which remains unperformed at that time. For the purposes of determining the nature and extent of unperformed obligations, the Contract shall be deemed to remain in force.

11.11 Clearance of Site

- 1111 Upon receiving the Completion Certificate, the Contractor shall remove any remaining Contractor's Equipment, surplus material, wreckage, rubbish and Temporary Works from the Site.
- 1112 If all these items have not been removed within 30 days after receipt by the Contractor of the Completion Certificate, the Procuring Entity may sell or otherwise dispose of any remaining items. The Procuring Entity shall be entitled to be paid the costs incurred in connection with, or attributable to, such sale or disposal and restoring the Site.
- 1113 Any balance of the moneys from the sale shall be paid to the Contractor. If these moneys are less than the Procuring Entity's costs, the Contractor shall pay the outstanding balance to the Procuring Entity.

12 MEASUREMENT AND DEVALUATION

12.1 Works to be Measured

- 1211 The Works shall be measured, and valued for payment, in accordance with this Clause. The Contractor shall show in each application under Sub-Clauses 14.3 [Application for Interim Payment Certificates], 14.10 [Statement on Completion] and 14.11 [Application for Final Payment Certificate] the quantities and other particulars detailing the amounts which he considers to be entitled under the Contract.
- 1212 Whenever the Architect requires any part of the Works to be measured, reasonable notice shall be given to the Contractor's Representative, who shall:
- a) promptly either attend or send another qualified representative to assist the Architect in making the measurement, and
 - b) supply any particulars requested by the Engineer.
- 1213 If the Contractor fails to attend or send a representative, the measurement made by the Architect shall be accepted as accurate.
- 1214 Except as otherwise stated in the Contract, wherever any Permanent Works are to

be measured from records, these shall be prepared by the Engineer. The Contractor shall, as and when requested, attend to examine and agree to the records with the Engineer, and shall sign the same when agreed. If the Contractor does not attend, the records shall be accepted as accurate.

12.15 If the Contractor examines and disagrees the records, and/ or does not sign them as agreed, then the Contractor shall give notice to the Architect of the respects in which the records are asserted to be inaccurate. After receiving this notice, the Architect shall review the records and either confirm or vary them and certify the payment of the undisputed part. If the Contractor does not so give notice to the Architect within 14 days after being requested to examine the records, they shall be accepted as accurate.

12.2 *Method of Measurement*

Except as otherwise stated in the Contract:

- a) Measurement shall be made of the net actual quantity of each item of the Permanent Works, and
- b) the method of measurement shall be in accordance with the Bill of Quantities or other applicable Schedules.

12.3 *Evaluation*

12.31 Except as otherwise stated in the Contract, the Architect shall proceed in accordance with Sub-Clause 3.5 [Determinations] to agree or determine the value of work done by evaluating each item of work, applying the measurement agreed or determined in accordance with the above Sub-Clauses 12.1 and 12.2 and the appropriate rate or price for the item.

12.32 For each item of work, the appropriate rate or price for the item shall be the rate or price specified for such item in the Contractor, if there is no such item, specified for similar work.

12.33 Any item of work included in the Bill of Quantities for which no rate or price was specified shall be considered as included in other rates and prices in the Bill of Quantities and will not be paid for separately.

12.34 However, for a new item of work, a new rate or price shall be appropriate for such item of work if:

- a) The work is instructed under Clause 13 [Variations and Adjustments],
- b) no rate or price is specified in the Contract for this item, and
- c) no specified rate or price is appropriate because the item of work is not of similar character, or is not executed under similar conditions, as any item in the Contract.

12.35 Each new rate or price shall be derived from any relevant rates or prices in the Contract. If no rates or prices are relevant for the new item of work, it shall be derived from the reasonable Cost of executing such work, prevailing market rates, together with profit, taking account of any other relevant matters.

12.36 Until such time as an appropriate rate or price is agreed or determined, the Architect shall determine a provisional rate or price for the purposes of Interim Payment Certificates as soon as the concerned work commences.

12.37 Where the contract price is different from the corrected tender price, in order to ensure the contractor is not paid less or more relative to the contract price (*which would be the tender price*), payment valuation certificates and variation orders on omissions and additions valued based on rates in the Bill of Quantities or schedule of rates in the Tender, will be adjusted by a plus or minus percentage. The percentage already worked out during tender evaluation is worked out as follows: *(corrected tender price – tender price) / tender price X 100*.

12.4 Omissions

Whenever the omission of any work forms part (or all) of a Variation, the value of which has not been agreed, if:

- a) The Contractor will incur (or has incurred) cost which, if the work had not been omitted, would have been deemed to be covered by a sum forming part of the Accepted Contract Amount;
- b) The omission of the work will result (or has resulted) in this sum not forming part of the Contract Price; and
- c) this cost is not deemed to be included in the evaluation of any substituted work; then the Contractor shall give notice to the Architect accordingly, with supporting particulars. Upon receiving this notice, the Architect shall proceed in accordance with Sub-Clause 3.5 [Determinations] to agree or determine this cost, which shall be included in the Contract Price.

B VARIATIONS AND ADJUSTMENTS

13.1 Right to Vary

13.1 Variations may be initiated by the Architect at any time prior to issuing the Taking-Over Certificate for the Works, either by an instruction or by a request for the Contractor to submit a proposal. No Variation instructed by the Architect under this Clause shall in any way vitiate or invalidate the Contract.

13.2 The Contractor shall execute and be bound by each Variation, unless the Contractor promptly gives notice to the Architect stating (with supporting particulars) that (i) the Contractor cannot readily obtain the Goods required for the Variation, or (ii) such Variation triggers a substantial change in the sequence or progress of the Works. Upon receiving this notice, the Architect shall cancel, confirm or vary the instruction.

13.3 Each Variation may include:

- a) changes to the quantities of any item of work included in the Contract (however, such changes do not necessarily constitute a Variation),
- b) changes to the quality and other characteristics of any item of work,
- c) changes to the levels, positions and/ or dimensions of any part of the Works,
- d) omission of any work unless it is to be carried out by others,
- e) any additional work, Plant, Materials or services necessary for the Permanent Works, including any associated Tests on Completion, boreholes and other testing and exploratory work, or
- f) changes to the sequence or timing of the execution of the Works.

13.4 The Contractor shall not make any alteration and/or modification of the Permanent Works, unless and until the Architect instructs after obtaining approval of the Procuring Entity.

13.2 Variation Order Procedure

13.2.1 Prior to any Variation Order under Sub-Clause 13.1.4 the Architect shall notify the Contractor of the nature and form of such variation. As soon as possible after having received such notice, the Contractor shall submit to the Engineer:

- a) A description of work, if any, to be performed and a programme for its execution, and
- b) the Contractor's proposals for any necessary modifications to the Programme according to Sub-Clause 8.3 or to any of the Contractor's obligations under the Contract, and
- c) the Contractor's proposals for adjustment to the Contract Price.

Following the receipt of the Contractor's submission the Architect shall, after due consultation with the Employer and the Contractor, decide as soon as possible whether or not the variation shall be carried out. If the Architect decides that the variation shall be carried out, he shall issue a Variation Order clearly identified as such in accordance with the Contractor's submission or as modified by agreement.

If the Architect and the Contractor are unable to agree the adjustment of the Contract Price, the provisions of Sub-Clause 13.2.2 shall apply.

13.2.2 Disagreement on Adjustment of the Contract Price

If the Contractor and the Architecture unable to agree on the adjustment of the Contract Price, the adjustment shall be determined in accordance with the rates specified in the Bills of Quantities or Schedule of Daywork Prices. If the rates contained in the Bills of Quantities or Dayworks Prices are not directly applicable to the specific work in question, suitable rates shall be established by the Architect reflecting the level of pricing in the Dayworks Prices. Where rates are not contained in the said Prices, the amount shall be such as is in all the circumstances reasonable, reflecting a market price. Due account shall be taken of any over-or under-recovery of overheads by the Contractor in consequence of the variation. The Contractor shall also be entitled to be paid:

- a) The cost of any partial execution of the Work rendered useless by any such variation,
- b) The cost of making necessary alterations to Plant already manufactured or in the course of manufacture or of any work done that has to be altered in consequence of such a variation,
- c) any additional costs incurred by the Contractor by the disruption of the progress of the Works as detailed in the Programme, and
- d) the net effect of the Contractor's finance costs, including interest, caused by the variation.

The Architect shall on this basis determine the rates or prices to enable on-account payment to be included in certificates of payment.

13.2.3 Contractor to Proceed

On receipt of a Variation Order, the Contractor shall forth with proceed to carry out the variation and be bound to these Conditions in so doing as if such variation was stated in the Contract. The work shall not be delayed pending the granting of an extension of the Time for Completion or an adjustment to the Contract Price under Sub-Clause 13.3.

13.3 Value Engineering

- 13.3.1 The Contractor may, at anytime, submit to the Architect written proposal which (in the Contractor's opinion) will, if adopted, (i) accelerate completion, (ii) reduce the cost to the Procuring Entity of executing, maintaining or operating the Works, (iii) improve the efficiency or value to the Procuring Entity of the completed Works, or (iv) otherwise be of benefit to the Procuring Entity.
- 13.3.2 The proposal shall be prepared at the cost of the Contractor and shall include the items listed in Sub-Clause 13.3 [Variation Procedure].
- 13.2.3 If a proposal, which is approved by the Engineer, includes a change in the design of part of the Permanent Works, then unless otherwise agreed by both Parties:
- a) The Contractor shall design this part,
 - b) sub-paragraphs (a) to (d) of Sub-Clause 4.1 [Contractor's General Obligations] shall apply, and
 - c) if this change results in a reduction in the contract value of this part, the Architect shall proceed in accordance with Sub-Clause 3.5 [Determinations] to agree or determine a fee, which shall be included in the Contract Price. This fee shall be half (50%) of the difference between the following amounts:
 - i) such reduction in contract value, resulting from the change, excluding adjustments under Sub-Clause 13.8 [Adjustments for Changes in Legislation] and Sub-Clause 13.8 [Adjustments for Changes in Cost], and
 - ii) the reduction (if any) in the value to the Procuring Entity of the varied works, taking account of any improvement in quality, anticipated life or operational efficiencies.
- 13.3.4 However, if the amount established in item 13.2.3 (c) (i) is less than amount established in item 13.2.3 (c) (ii), there shall not be a fee. However, if the amount established in item 13.2.3 (c) (i) is more than amount established in item 13.2.3 (c) (ii), it shall result in a price variation to the Procuring Entity.

13.4 Variation Procedure for Value Engineering proposal

- 13.4.1 If the Architect requests a proposal, prior to instructing a Variation, the Contractor shall respond in writing as soon as practicable, either by giving reasons why he cannot comply (if this is the case) or by submitting:
- a) A description of the proposed work to be performed and a programme for its execution,
 - b) the Contractor's proposal for any necessary modifications to the programme according to Sub-Clause 8.3 [Programme] and to the Time for Completion, and
 - c) the Contractor's proposal for evaluation of the Variation.
- 13.4.2 The Architect shall, as soon as practicable after receiving such proposal (under Sub-Clause 13.2 [Value Project Engineering] or otherwise), respond with approval, disapproval or comments. The Contractor shall not delay any work whilst a waiting a response.
- 13.4.3 Each instruction to execute a Variation, with any requirements for the recording of Costs, shall be issued by the Architect to the Contractor, who shall acknowledge receipt.
- 13.4.4 Each Variation shall be evaluated in accordance with Clause 12 [Measurement and Evaluation], unless the Architect instructs or approves otherwise in accordance with

this Clause.

135 Payment in Applicable Currencies

If the Contract provides for payment of the Contract Price in more than one currency, then whenever an adjustment is agreed, approved or determined as stated above, the amount payable in each of the applicable currencies shall be specified. For this purpose, reference shall be made to the actual or expected currency proportions of the Cost of the varied work, and to the proportions of various currencies specified for payment of the Contract Price.

136 Provisional Sums

13.6.1 Each Provisional Sum shall only be used, in whole or in part, in accordance with the Architect instructions, and the Contract Price shall be adjusted accordingly. The total sum paid to the Contractor shall include only such amounts, for the work, supplies or services to which the Provisional Sum relates, as the Architect shall have instructed. For each Provisional Sum, the Architect May instruct:

- a) Work to be executed (including Plant, Materials or services to be supplied) by the Contractor and valued under Sub-Clause 13.3 [Variation Procedure]; and/or
- b) Plant, Materials or services to be purchased by the Contractor, from a nominated Subcontractor (as defined in Clause 5 [Nominated Subcontractors]) or otherwise; and for which there shall be included in the Contract Price:
 - i) The actual amounts paid (or due to be paid) by the Contractor, and
 - ii) a sum for overhead charges and profit, calculated as a percentage of these actual amounts by applying the relevant percentage rate (if any) stated in the appropriate Schedule. If there is no such rate, the percentage rate stated in the **Special Conditions of Contract** shall be applied.

13.6.2 The Contractor shall, when required by the Engineer, produce quotations, invoices, vouchers and accounts or receipts in substantiation.

137 Dayworks

13.7.1 For work of a minor or incidental nature, the Architect may instruct that a Variation shall be executed on a daywork basis. The work shall then be valued in accordance with the Daywork Schedule included in the Contract, and the following procedure shall apply. If a Daywork Schedule is not included in the Contract, this Sub-Clause shall not apply.

13.7.2 Before ordering Goods for the work, the Contractor shall submit quotations to the Engineer. When applying for payment, the Contractor shall submit invoices, vouchers and accounts or receipts for any Goods.

13.7.3 Except for any items for which the Daywork Schedule specifies that payment is not due, the Contractor shall deliver each day to the Architect accurate statements in duplicate which shall include the following details of the resources used in executing the previous day's work:

- a) The names, occupations and time of Contractor's Personnel,
- b) the identification, type and time of Contractor's Equipment and Temporary Works, and

c) the quantities and types of Plant and Materials used.

13.7.4 One copy of each statement will, if correct, or when agreed, be signed by the Architect and returned to the Contractor. The Contractor shall then submit priced statements of these resources to the Engineer, prior to their inclusion in the next Statement under Sub-Clause 14.3 [Application for Interim Payment Certificates].

13.8 Adjustments for Changes in Legislation

13.8.1 The Contract Price shall be adjusted to take account of any increase or decrease in Cost resulting from a change in the Laws of Kenya (including the introduction of new Laws and the repeal or modification of existing Laws) or in the judicial or official governmental interpretation of such Laws, made after the Base Date, which affect the Contractor in the performance of obligations under the Contract.

13.8.2 If the Contractor suffers (or will suffer) delay and/or incurs (or will incur) additional Cost as a result of these changes in the Laws or in such interpretations, made after the Base Date, the Contractor shall give notice to the Architect and shall be entitled subject to Sub-Clause 20.1 [Contractor's Claims] to:

- a) an extension of time for any such delay, if completion is or will be delayed, under Sub-Clause 8.4 [Extension of Time for Completion], and
- b) payment of any such Cost, which shall be included in the Contract Price.

13.8.3 After receiving this notice, the Architect shall proceed in accordance with Sub-Clause 3.5 [Determinations] to agree or determine these matters.

13.8.4 Notwithstanding the foregoing, the Contractor shall not be entitled to an extension of time if the relevant delay has already been taken into account in the determination of a previous extension of time and such Cost shall not be separately paid if the same shall already have been taken into account in the indexing of any inputs to the table of adjustment data in accordance with the provisions of Sub-Clause 13.8 [Adjustments for Changes in Cost].

13.9 Adjustments for Changes in Cost

13.9.1 In this Sub-Clause, "table of adjustment data" means the completed table of adjustment data for local and foreign currencies included in the Schedules. If there is no such table of adjustment data, this Sub-Clause shall not apply.

13.9.2 If this Sub-Clause applies, the amounts payable to the Contractor shall be adjusted for rises or falls in the cost of labor, Goods and other inputs to the Works, by the addition or deduction of the amounts determined by the formulae prescribed in this Sub-Clause. To the extent that full compensation for any rise or fall in Costs is not covered by the provisions of this or other Clauses, the Accepted Contract Amount shall be deemed to have included a mounts to cover the contingency of other rises and falls in costs.

13.9.3 The adjustment to be applied to the amount otherwise payable to the Contractor, as valued in accordance with the appropriate Schedule and certified in Payment Certificates, shall be determined from formulae for each of the currencies in which the Contract Price is payable. No adjustment is to be applied to work valued on the basis of Cost or current prices. The formulae shall be of the following general type:

Price Adjustment Formula

Prices shall be adjusted for fluctuations in the cost of inputs only if **provided for in the SCC**. If so provided, the amounts certified in each payment certificate, before deducting for Advance Payment, shall be adjusted by applying the respective price adjustment factor to the payment amounts due in each currency. A separate formula of the type specified below applies:

$$P = A + B I_m/I_o$$

where:

P is the adjustment factor for the portion of the Contract Price payable.

A and **B** are coefficients **specified in the SCC**, representing then on adjustable and adjustable portions, respectively, of the Contract Price payable and

I_m is the index prevailing at the end of the month being invoiced and **I_o** is the index prevailing 30 days before Bid opening for inputs payable.

NOTE: The sum of the two coefficients A and B should be 1 (one) in the formula for each currency. Normally, both coefficients shall be the same in the formulae for all currencies, since coefficient A, for the non adjustable portion of the payments, is a very approximate figure (usually 0.15) to

- 1394 The cost indices or reference prices stated in the table of adjustment data shall be used. If their source is in doubt, it shall be determined by the Engineer. Forth purpose, reference shall be made to the values of the indices at stated dates (quoted in the fourth and fifth columns respectively of the table) for the purposes of clarification of the source; although these dates (and thus these values) may not correspond to the base cost indices.
- 1395 Incases where the “currency of index” is not the relevant currency of payment, each index shall be converted into the relevant currency of payment at the selling rate, established by the Central Bank of Kenya, of this relevant currency on the above date for which the index is required to be applicable.
- 1396 Until such time as each current cost index is available, the Architect shall determine a provisional index for the issue of Interim Payment Certificates. When a current cost index is available, the adjustment shall be recalculated accordingly.
- 1397 If the Contractor fails to complete the Works within the Time for Completion, adjustment of prices there after shall be made using either (i) each index or price applicable on the date 49 days prior to the expiry of the Time for Completion of the Works, or (ii) the current index or price, whichever is more favorable to the Procuring Entity.
- 1398 The weightings (coefficients) for each of the factors of cost stated in the table(s) of adjustment data shall only be adjusted if they have been rendered unreasonable, unbalanced or in applicable, as a result of Variations.

CONTRACT PRICE AND PAYMENT

14.1 The Contract Price

- ~~14.1~~ Unless otherwise stated in the Special Conditions:
- a) The value of the payment certificate shall be agreed or determined under Sub-Clause 12.3 [Evaluation] and be subject to adjustments in accordance with the Contract;
 - b) the Contractor shall pay all taxes, duties and fees required to be paid by him under the Contract, and the Contract Price shall not be adjusted for any of these costs except as stated in Sub-Clause 13.7 [Adjustments for Changes in Legislation];
 - c) any quantities which may be set out in the Bill of Quantities or other Schedule are estimated quantities and are not to be taken as the actual and correct quantities:
 - i) of the Works which the Contractor is required to execute, or
 - ii) for the purposes of Clause 12 [Measurement and Evaluation]; and
 - d) the Contractor shall submit to the Engineer, within 30 days after the Commencement Date, a proposed breakdown of each lump sum price in the Schedules. The Architect may take account of the break down when preparing Payment Certificates but shall not be bound by it.

~~14.2~~ Notwithstanding the provisions of subparagraph (b), Contractor's Equipment, including essential spare parts there for, imported by the Contractor for the sole purpose of executing the Contract shall not be exempt from the payment of import duties and taxes upon importation.

14.2 *Advance Payment*

~~14.21~~ The Procuring Entity shall make an advance payment, as an interest-free loan for mobilization and cashflow support, when the Contractor submits a guarantee in accordance with this Clause. The total advance payment, the number and timing of instalments (if more than one), and the applicable currencies and proportions, shall be as stated in the **Special Conditions of Contract**.

~~14.22~~ Unless and until the Procuring Entity receives this guarantee, or if the total advance payment is not stated in the Special Conditions of Contract, this Sub-Clause shall not apply.

~~14.23~~ The Architect shall deliver to the Procuring Entity and to the Contractor an Interim Payment Certificate for the advance payment or its first instalment after receiving a Statement (under Sub-Clause 14.3 [Application for Interim Payment Certificates]) and after the Procuring Entity receives (i) the Performance Security in accordance with Sub-Clause 4.2 [Performance Security] and (ii) a guarantee in amounts and currencies equal to the advance payment. This guarantee shall be issued by a reputable bank or financial institutions elected by the Contractor and shall be in the form annexed to the Special Conditions or in another form approved by the Procuring Entity.

~~14.24~~ The Contractor shall ensure that the guarantee is valid and enforceable until the advance payment has been repaid, but its amount shall be progressively reduced by

the amount repaid by the Contractor as indicated in the Payment Certificates. If the terms of the guarantee specify its expiry date, and the advance payment has not been repaid by the date 30 days prior to the expiry date, the Contractor shall extend the validity of the guarantee until the advance payment has been repaid.

- 14.25 Unless stated otherwise in **the Special Conditions of Contract**, the advance payment shall be repaid through percentage deductions from the interim payments determined by the Architect in accordance with Sub-Clause 14.6 [Issue of Interim Payment Certificates], as follows:
- a) Deductions shall commence in the next interim Payment Certificate following that in which the total of all certified interim payments (excluding the advance payment and deductions and repayments of retention) exceeds 30 percent (30%) of the Accepted Contract Amount less Provisional Sums; and
 - b) deductions shall be made at the amortization rate stated in the **Special Conditions of Contract** of the amount of each Interim Payment Certificate (excluding the advance payment and deductions for its repayments as well as deductions for retention money) in the currencies and proportions of the advance payment until such time as the advance payment has been repaid; provided that the advance payment shall be completely repaid prior to the time when 90 percent (90%) of the Accepted Contract Amount less Provisional Sums has been certified for payment.

- 14.26 If the advance payment has not been repaid prior to the issue of the Taking-Over Certificate for the Works or prior to termination under Clause 15 [Termination by Procuring Entity], Clause 16 [Suspension and Termination by Contractor] or Clause 19 [Force Majeure] (as the case may be), the whole of the balance then outstanding shall immediately become due and in case of termination under Clause 15 [Termination by Procuring Entity], except for Sub-Clause 14.2.7 [Procuring Entity's Entitlement to Termination for Convenience], payable by the Contractor to the Procuring Entity.

14.3 Application for Interim Payment Certificates

- 14.31 The Contractor shall submit a Statement (in number of copies indicated in the **Special Conditions of Contract**) to the Architect after the end of each month, in a form approved by the Engineer, showing in detail the amounts to which the Contractor considers itself to be entitled, together with supporting documents which shall include there portion the progress during this month in accordance with Sub-Clause 4.21 [Progress Reports].
- 14.32 The Statement shall include the following items, as applicable, which shall be expressed in the various currencies in which the Contract Price is payable, in the sequence listed:
- a) the estimated contract value of the Works executed and the Contractor's Documents produced up to the end of the month (including Variations but excluding items described in sub-paragraphs (b) to (g) below);
 - b) any amounts to be added and deducted for changes in legislation and changes in cost, in accordance with Sub-Clause 13.7 [Adjustments for Changes in Legislation] and Sub-Clause 13.8 [Adjustments for Changes in Cost];
 - c) any amount to be deducted for retention, calculated by applying the percentage of retention stated in **the Special Conditions of Contract** to the total of the

above amounts, until the amount so retained by the Procuring Entity reaches the limit of Retention Money (if any) stated in the **Special Conditions of Contract**;

- d) any amounts to be added for the advance payment and (if more than one instalment) and to be deducted for its repayments in accordance with Sub-Clause 14.2 [Advance Payment];
- e) any amounts to be added and deducted for Plant and Materials in accordance with Sub-Clause 14.5 [Plant and Materials intended for the Works];
- f) any other additions or deductions which may have become due under the Contractor otherwise, including those under Clause 20 [Claims, Disputes and Arbitration]; and
- g) the deduction of amounts certified in all previous Payment Certificates.

14.4 *Schedule of Payments*

~~14.1~~ If the Contract includes a schedule of payments specifying the instalments in which the Contract Price will be paid, then unless otherwise stated in this schedule:

- a) The instalments quoted in this schedule of payments shall be the estimated contract values for the purposes of sub-paragraph (a) of Sub-Clause 14.3 [Application for Interim Payment Certificates];
- b) Sub-Clause 14.5 [Plant and Materials intended for the Works] shall not apply; and
- c) If these instalments are not defined by reference to the actual progress achieved in executing the Works, and if actual progress is found to be less or more than that on which this schedule of payments was based, then the Architect may proceed in accordance with Sub-Clause 3.5 [Determinations] to agree or determine revised instalments, which shall take account of the extent to which progress is less or more than that on which the instalments were previously based.

~~14.2~~ If the Contract does not include a schedule of payments, the Contractor shall submit non-binding estimates of the payments which he expects to become due during each quarterly period. The first estimate shall be submitted within 42 days after the Commencement Date. Revised estimates shall be submitted at quarterly intervals, until the Taking-Over Certificate has been issued for the Works.

14.5 *Plant and Materials intended for the Works*

~~14.51~~ If this Sub-Clause applies, Interim Payment Certificates shall include, under sub-paragraph (e) of Sub-Clause 14.3, (i) an amount for Plant and Materials which have been sent to the Site for incorporation in the Permanent Works, and (ii) a reduction when the contract value of such Plant and Materials is included as part of the Permanent Works under sub-paragraph (a) of Sub-Clause 14.3 [Application for Interim Payment Certificates].

~~14.52~~ If the lists referred to in sub-paragraphs (b)(i) or (c)(i) below are not included in the Schedules, this Sub-Clause shall not apply.

- 14.5.3 The Architect shall determine and certify each addition if the following conditions are satisfied:
- a) The Contractor has:
 - i) kept satisfactory records (including the orders, receipts, Costs and use of Plant and Materials) which are available for inspection, and
 - ii) submitted statement of the Cost of acquiring and delivering the Plant and Materials to the Site, supported by satisfactory evidence;and either:
 - b) the relevant Plant and Materials:
 - i) are those listed in the Schedules for payment when shipped,
 - ii) have been shipped to Kenya, enroute to the Site, in accordance with the Contract; and
 - iii) are described in a clean shipped bill of lading or other evidence of shipment, which has been submitted to the Architect together with evidence of payment of freight and insurance, any other documents reasonably required, and a bank guarantee in a form and issued by an entity approved by the Procuring Entity in amounts and currencies equal to the amount due under this Sub-Clause: this guarantee may be in a similar form to the form referred to in Sub-Clause 14.2 [Advance Payment] and shall be valid until the Plant and Materials are properly stored on Site and protected against loss, damage or deterioration; or
 - c) the relevant Plant and Materials:
 - i) are those listed in the Schedules for payment when delivered to the Site, and
 - ii) have been delivered to and are properly stored on the Site, are protected against loss, damage or deterioration and appear to be in accordance with the Contract.

14.5.4 The additional amount to be certified shall be the equivalent of eighty percent (80%) of the Architect determination of the cost of the Plant and Materials (including delivery to Site), taking account of the documents mentioned in this Sub-Clause and of the contract value of the Plant and Materials.

14.5.5 The currencies for this additional amount shall be the same as those in which payment will become due when the contract value is included under sub-paragraph (a) of Sub-Clause 14.3 [Application for Interim Payment Certificates]. At that time, the Payment Certificate shall include the applicable reduction which shall be equivalent to, and in the same currencies and proportions as, this additional amount for the relevant Plant and Materials.

14.6 Issue of Interim Payment Certificates

14.6.1 No amount will be certified or paid until the Procuring Entity has received and approved the Performance Security. Thereafter, the Architect shall, within 30 days after receiving a Statement and supporting documents, deliver to the Procuring Entity and to the Contractor an Interim Payment Certificate which shall state the amount which the Architect fairly determines to be due, with all supporting particulars for any reduction or withholding made by the Architect on the Statement if any.

14.62 However, prior to issuing the Taking-Over Certificate for the Works, the Architect shall not be bound to issue an Interim Payment Certificate in an amount which would (after retention and other deductions) be less than the minimum amount of Interim Payment Certificates (if any) stated in the **Special Conditions of Contract**. In this event, the Architect shall give notice to the Contractor accordingly.

14.63 An Interim Payment Certificate shall not be withheld for any other reason, although:

- a) if anything supplied or work done by the Contractor is not in accordance with the Contract, the cost of rectification or replacement may be withheld until rectification or replacement has been completed; and/or
- b) if the Contractor was or is failing to perform any work or obligation in accordance with the Contract, and had been so notified by the Engineer, the value of this work or obligation may be withheld until the work or obligation has been performed.

4.6.4 The Architect may in any Payment Certificate make any correction or modification that should properly be made to any previous Payment Certificate. A Payment Certificate shall not be deemed to indicate the Architect acceptance, approval, consent or satisfaction.

14.7 *Payment*

14.7.1 The Procuring Entity shall pay to the Contractor:

- a) The advance payment shall be paid within 60 days after signing of the contract by both parties or within 60 days after receiving the documents in accordance with Sub-Clause 4.2 [Performance Security] and Sub- Clause 14.2 [Advance Payment], which ever is later;
- b) The amount certified in each Interim Payment Certificate within 60 days after the Architect Issues Interim Payment Certificate; and
- c) the amount certified in the Final Payment Certificate within 60 days after the Procuring Entity Issues Interim Payment Certificate; or after determination of any disputed amount shown in the Final Statement in accordance with Sub-Clause 16.2 [Termination by Contractor].

14.7.2 Payment of the amount due in each currency shall be made into the bank account, nominated by the Contractor, in the payment country (forth is currency) specified in the Contract.

14.8 *Delayed Payment*

14.8.1 If the Contractor does not receive payment in accordance with Sub-Clause 14.7 [Payment], the Contractor shall be entitled to receive financing charges (simple interest) monthly on the amount unpaid during the period of delay. This period shall be deemed to commence on the date for payment specified in Sub-Clause 14.7 [Payment], irrespective (in the case of its sub-paragraph (b) of the date on which any Interim Payment Certificate is issued.

14.8.2 These financing charges shall be calculated at the annual rate of three percentage points above the mean rate of the Central Bank in Kenya of the currency of payment,

or if not available, the inter bank offered rate, and shall be paid in such currency.

14.8.3 The Contractor shall be entitled to this payment without formal notice and certification, and without prejudice to any other right or remedy.

14.9 Payment of Retention Money

14.9.1 When the Taking-Over Certificate has been issued for the Works, the first half of the Retention Money shall be certified by the Architect for payment to the Contractor. If a Taking-Over Certificate is issued for a Section or part of the Works, a proportion of the Retention Money shall be certified and paid. This proportion shall be half (50%) of the proportion calculated by dividing the estimated contract value of the Section or part, by the estimated final Contract Price.

14.9.2 Promptly after the latest of the expiry dates of the Defects Liability Periods, the outstanding balance of the Retention Money shall be certified by the Architect for payment to the Contractor. If a Taking-Over Certificate was issued for a Section, a proportion of the second half of the Retention Money shall be certified and paid promptly after the expiry date of the Defects Notification Period for the Section. This proportion shall be half (50%) of the proportion calculated by dividing the estimated contract value of the Section by the estimated final Contract Price.

14.9.3 However, if any work remains to be executed under Clause 11 [Defects Liability], the Architects shall be entitled to withhold certification of the estimated cost of this work until it has been executed.

14.9.4 When calculating these proportions, no account shall be taken of any adjustments under Sub-Clause 13.7 [Adjustments for Changes in Legislation] and Sub-Clause 13.8 [Adjustments for Changes in Cost].

14.9.5 Unless otherwise stated in the Special Conditions, when the Taking-Over Certificate has been issued for the Works and the first half of the Retention Money has been certified for payment by the Engineer, the Contractor shall be entitled to substitute a Retention Money Security guarantee, in the form annexed to the Special Conditions or in another form approved by the Procuring Entity and issued by a reputable bank or financial institution selected by the Contractor, for the second half of the Retention Money.

14.9.6 The Procuring Entity shall return the Retention Money Security guarantee to the Contractor within 14 days after receiving a copy of the Completion Certificate.

14.10 Statement at Completion

14.10.1 Within 84 days after receiving the Taking-Over Certificate for the Works, the Contractor shall submit to the Architect three copies of a Statement at completion with supporting documents, in accordance with Sub-Clause 14.3 [Application for Interim Payment Certificates], showing:

- a) the value of all work done in accordance with the Contract up to the date stated in the Taking-Over Certificate for the Works,
- b) any further sums which the Contractor considers to be due, and

- c) an estimate of any other amounts which the Contractor considers will become due to him under the Contract. Estimated amounts shall be shown separately in this Statement at completion.

14.10.2 The Architect shall then certify in accordance with Sub-Clause 14.6 [Issue of Interim Payment Certificates].

14.11 Application for Final Payment Certificate

14.11.1 Within 60 days after receiving the Completion Certificate, the Contractor shall submit, to the Engineer, six copies of a draft final statement with supporting documents showing in detail in a form approved by the Engineer:

- a) The value of all work done in accordance with the Contract, and
- b) Any further sums which the Contractor considers to be due to him under the Contract otherwise.

14.11.2 If the Architect disagrees with or cannot verify any part of the draft final statement, the Contractor shall submit such further information as the Architect may reasonably require within 30 days from receipt of said draft and shall make such changes in the draft as may be agreed between them. The Contractor shall then prepare and submit to the Architect the final statement as agreed. This agreed statement is referred to in these Conditions as the "Final Statement".

14.11.3 However, if, following discussions between the Architect and the Contractor and any changes to the draft final statement which are agreed, it becomes evident that a dispute exists, the Architect shall deliver to the Procuring Entity (with a copy to the Contractor) an Interim Payment Certificate for the agreed parts of the draft final statement. Thereafter, if the dispute is finally resolved under Sub-Clause 20.4 [Obtaining Dispute Board's Decision] or Sub-Clause 20.5 [Amicable Settlement], the Contractor shall then prepare and submit to the Procuring Entity (with a copy to the Engineer) a Final Statement.

14.12 Discharge

When submitting the Final Statement, the Contractor shall submit a discharge which confirms that the total of the Final Statement represents full and final settlement of all moneys due to the Contractor under or in connection with the Contract. This discharge may state that it becomes effective when the Contractor has received the Performance Security and the out standing balance of this total, in which event the discharge shall be effective on such date.

14.13 Issue of Final Payment Certificate

14.13.1 Within 30 days after receiving the Final Statement and discharge in accordance with Sub-Clause 14.11 [Application for Final Payment Certificate] and Sub-Clause 14.12 [Discharge], the Architect shall deliver, to the Procuring Entity and to the Contractor, the Final Payment Certificate which shall state:

- a) The amount which he fairly determines is finally due, and
- b) After giving credit to the Procuring Entity for all amounts previously paid by the Procuring Entity and for all sums to which the Procuring Entity is entitled, the balance (if any) due from the Procuring Entity to the Contractor or from

the Contractor to the Procuring Entity, as the case may be.

- 14.13.2 If the Contractor has not applied for a Final Payment Certificate in accordance with Sub-Clause 14.11 [Application for Final Payment Certificate] and Sub-Clause 14.12 [Discharge], the Architect shall request the Contractor to do so. If the Contractor fails to submit an application within a period of 30 days, the Architect shall issue the Final Payment Certificate for such amount as he fairly determines to be due.

14.14 Cessation of Procuring Entity's Liability

- 14.14.1 The Procuring Entity shall not be liable to the Contractor for any matter or thing under or in connection with the Contract or execution of the Works, except to the extent that the Contractor shall have included an amount expressly for it:
- a) in the Final Statement and also,
 - b) (except for matters or things arising after the issue of the Taking-Over Certificate for the Works) in the Statement at completion described in Sub-Clause 14.10 [Statement at Completion].
- 14.14.2 However, this Sub-Clause shall not limit the Procuring Entity's liability under his indemnification obligations, or the Procuring Entity's liability in any case of fraud, deliberate default or reckless misconduct by the Procuring Entity.

14.15 Currencies of Payment

The Contract Price shall be paid in the currency or currencies named in the Schedule of Payment Currencies. If more than one currency is so named, payments shall be made as follows:

- a) If the Accepted Contract Amount was expressed in Local Currency only:
 - i) the proportions or amounts of the Local and Foreign Currencies, and the fixed rates of exchange to be used for calculating the payments, shall be as stated in the Schedule of Payment Currencies, except as otherwise agreed by both Parties;
 - ii) payments and deductions under Sub-Clause 13.5 [Provisional Sums] and Sub-Clause 13.7 [Adjustments for Changes in Legislation] shall be made in the applicable currencies and proportions; and
 - iii) other payments and deductions under sub-paragraphs (a) to (d) of Sub-Clause 14.3 [Application for Interim Payment Certificates] shall be made in the currencies and proportions specified in sub-paragraph (a) (i) above;
- b) payment of the damages specified in the Special Conditions of Contract, shall be made in the currencies and proportions specified in the Schedule of Payment Currencies;
- c) other payments to the Procuring Entity by the Contractor shall be made in the currency in which the sum was expended by the Procuring Entity, or in such currency as may be agreed by both Parties;
- d) if any amount payable by the Contractor to the Procuring Entity in a particular currency exceeds the sum payable by the Procuring Entity to the Contractor in that currency, the Procuring Entity may recover the balance of this amount from

- the sums otherwise payable to the Contractor in other currencies; and
- e) if no rates of exchange are stated in the Schedule of Payment Currencies, they shall be those prevailing on the Base Date and determined by the Central Bank of Kenya.

6 *TERMINATION BY PROCURING ENTITY*

15.1 **Notice to correct any defects or failures**

If the Contractor fails to carry out any obligation under the Contract, the Architect may by notice require the Contractor to make good the failure and to remedy it within 30 days.

15.2 *Termination by Procuring Entity*

- 15.21** The Procuring Entity shall be entitled to terminate the Contract if the Contractor breaches the contract based on following circumstances which shall include but not limited to:
- a) fails to comply with Sub-Clause 4.2 [Performance Security] or with a notice under Sub-Clause 15.1 [Notice to Correct],
 - b) abandons the Works or otherwise plainly demonstrates the intention not to continue performance of his obligations under the Contract,
 - c) without reasonable excuse fails:
 - i) to proceed with the Works in accordance with Clause 8 [Commencement, Delays and Suspension], or
 - ii) to comply with a notice issued under Sub-Clause 7.5 [Rejection] or Sub-Clause 7.6 [Remedial Work], within 30 days after receiving it,
 - d) subcontracts the major part or whole of the Works or assigns the Contract without the consent of the Procuring Entity,
 - e) becomes bankrupt or insolvent, goes into liquidation, has a receiving or administration order made against him, compounds with his creditors, or carries on business under a receiver, trustee or manager for the benefit of his creditors, or if any act is done or event occurs which (under applicable Laws) has a similar effect to any of these acts or events, or
 - f) gives or offers to give (directly or indirectly) to any person any bribe, gift, gratuity, commission or other thing of value, as an induce mentor reward:
 - i) for doing or for bearing to do any action in relation to the Contract, or
 - ii) for showing or for bearing to show favor or disfavor to any person in relation to the Contract, or
 - iii) if any of the Contractor's Personnel, agents or Subcontractors gives or offers to give (directly or indirectly) to any person any such induce mentor reward as is described in this sub-paragraph (f). However, lawful inducements and rewards to Contractor's Personnel shall not entitle termination, or
 - g) If the contract or repeatedly fails to remedy delivers defective work,
 - h) based on reasonable evidence, has engaged in Fraud and Corruption as defined in paragraph 2.2 of the Appendix B to these General Conditions, incompeting for or in executing the Contract.
- 15.22** In any of these events or circumstances, the Procuring Entity may, upon giving 14 days' notice to the Contractor, terminate the Contract and expel the Contractor

from the Site. However, in the case of sub- paragraph (e) or (f) or (g) or (h), the Procuring Entity may by notice terminate the Contract immediately.

15.23 The Procuring Entity's election to terminate the Contract shall not prejudice any other rights of the Procuring Entity, under the Contract otherwise.

15.24 The Contractor shall then leave the Site and deliver any required Goods, all Contractor's Documents, and other design documents made by or for him, to the Engineer. However, the Contractor shall use his best efforts to comply immediately with any reasonable instructions included in the notice (i) for the assignment of any subcontract, and (ii) for the protection of life or property or for the safety of the Works.

15.25 After termination, the Procuring Entity may complete the Works and/ or arrange for any other entities to do so. The Procuring Entity and these entities may then use any Goods, Contractor's Documents and other design documents made by or on behalf of the Contractor.

15.26 The Procuring Entity shall then give notice that the Contractor's Equipment and Temporary Works will be released to the Contractor at or near the Site. The Contractor shall promptly arrange their removal, at the risk and cost of the Contractor. However, if by this time the Contractor has failed to make a payment due to the Procuring Entity, these items may be sold by the Procuring Entity in order to recover this payment. Any balance of the proceeds shall then be paid to the Contractor.

15.3 *Valuation at Date of Termination*

As soon as practicable after a notice of termination under Sub-Clause 15.2 [Termination by Procuring Entity] has taken effect, the Architect shall proceed in accordance with Sub-Clause 3.5 [Determinations] to agree or determine the value of the Works, Goods and Contractor's Documents, and any other sums due to the Contractor for work executed in accordance with the Contract.

15.4 *Payment after Termination*

After a notice of termination under Sub-Clause 15.2 [Termination by Procuring Entity] has taken effect, the Procuring Entity may:

- a) Proceed in accordance with Sub-Clause 2.5 [Procuring Entity's Claims],
- b) withhold further payments to the Contractor until the costs of execution, completion and remedying of any defects, damages for delay in completion (if any), and all other costs incurred by the Procuring Entity, have been established, and/ or
- c) recover from the Contractor any losses and damages incurred by the Procuring Entity and any extra costs of completing the Works, after allowing for any sum due to the Contractor under Sub-Clause 15.3 [Valuation at Date of Termination]. After recovering any such losses, damages and extra costs, the Procuring Entity shall pay any balance to the Contractor.

15.5 *Procuring Entity's Entitlement to Termination for Convenience*

The Procuring Entity shall be entitled to terminate the Contract, at any time at the Procuring Entity's convenience, by giving notice of such termination to the

Contractor. The termination shall take effect 30 days after the later of the dates on which the Contractor receives this notice or the Procuring Entity returns the Performance Security. The Procuring Entity shall not terminate the Contract under this Sub-Clause in order to execute the Works itself or to arrange for the Works to be executed by another contractor or to avoid a termination of the Contract by the Contractor under Clause 16.2 [Termination by Contractor]. After this termination, the Contractor shall proceed in accordance with Sub-Clause 16.3 [Cessation of Work and Removal of Contractor's Equipment] and shall be paid in accordance with Sub-Clause 16.4 [Payment on Termination].

15.6 *Fraud and Corruption*

The Contractor shall ensure compliance with the Kenya Government's Anti-Corruption Laws and its prevailing sanctions.

15.7 *Corrupt gifts and payments of commission*

15.7.1 The Contractor shall not;

- a) Offer or give or agree to give to any person in the service of the Procuring Entity any gift or consideration of any kind as an inducement or reward for doing or for bearing to do or for borne to do any act in relation to the obtaining or execution of this or any other Contract for the Procuring Entity or for showing or for bearing to show favor or disfavor to any person in relation to this or any other contract for the Procuring Entity.
- b) Enter into this or any other contract with the Procuring Entity in connection with which commission has been paid or agreed to be paid by him or on his behalf or to his knowledge, unless before the Contract is made particulars of any such commission and of the terms and conditions of any agreement for the payment there of have been disclosed in writing to the Procuring Entity.

15.7.2 Any breach of this Condition by the Contractor or by anyone employed by him or acting on his behalf (whether with or without the knowledge of the Contractor) shall be an offence under the provisions of the Public Procurement and Asset Disposal Act (2015) and the Anti-Corruption and Economic Crimes Act (2003) of the Laws of Kenya.

16 *SUSPENSION AND TERMINATION BY CONTRACTOR*

16.1 *Contractor's Entitlement to Suspend Work*

16.1.1 If the Architect fails to certify in accordance with Sub-Clause 14.6 [Issue of Interim Payment Certificates] or Sub-Clause 14.7 [Payment], or not receiving instructions that would enable the contractor to proceed with the works in accordance with the program, the Contractor may, after giving not less than 30 days' notice to the Procuring Entity, suspend work (or reduce the rate of work) unless and until the Contractor has received the Payment Certificate, reasonable evidence or payment, as the case may be and as described in the notice.

16.1.2 The Contractor's action shall not prejudice his entitlements to financing charges under Sub-Clause 14.8 [Delayed Payment] and to termination under Sub-Clause 16.2 [Termination by Contractor].

16.13 If the Contractor subsequently receives such Payment Certificate, evidence or payment (as described in the relevant Sub-Clause and in the above notice) before giving a notice of termination, the Contractor shall resume normal working as soon as is reasonably practicable.

16.14 If the Contractor suffers delay and/or incurs Cost as a result of suspending work (or reducing the rate of work) in accordance with this Sub-Clause, the Contractor shall give notice to the Architect and shall be entitled subject to Sub-Clause 20.1 [Contractor's Claims] to:

- a) an extension of time for any such delay, if completion is or will be delayed, under Sub-Clause 8.4 [Extension of Time for Completion], and
- b) payment of any such Cost-plus profit, which shall be included in the Contract Price.

16.2 After receiving this notice, the Architect shall proceed in accordance with Sub-Clause 3.5 [Determinations] to agree or determine these matters.

16.3 *Termination by Contractor*

16.31 The Contractor shall be entitled to terminate the Contract if:

- a) the Architect fails, within 60 days after receiving a Statement and supporting documents, to issue the relevant Payment Certificate,
- b) the Contractor does not receive the amount due under an Interim Payment Certificate within 90 days after the expiry of the time stated in Sub-Clause 14.7 [Payment] within which payment is to be made (except for deductions in accordance with Sub-Clause 2.5 [Procuring Entity's Claims]),
- c) the Procuring Entity substantially fails to perform his obligations under the Contract in such manner as to materially and adversely affect the economic balance of the Contract and/or the ability of the Contractor to perform the Contract,
- d) a prolonged suspension affects the whole of the Works as described in Sub-Clause 8.11 [Prolonged Suspension], or
- e) the Procuring Entity becomes bankrupt or insolvent, goes into liquidation, has a receiving or administration order made against him, compounds with his creditors, or carries on business under a receiver, trustee or manager for the benefit of his creditors, or if any act is done or event occurs which (under applicable Laws) has a similar effect to any of these acts or events.
- f) the Contractor does not receive the Architect instruction recording the agreement of both Parties on the fulfilment of the conditions for the Commencement of Works under Sub-Clause 8.1 [Commencement of Works].

16.32 In any of these events or circumstances, the Contractor may, upon giving 14 days' notice to the Procuring Entity, terminate the Contract. However, in the case of subparagraph (f) or (g), the Contractor may by notice terminate the Contract immediately.

16.33 The Contractor's election to terminate the Contract shall not prejudice any other rights of the Contractor, under the Contract otherwise.

16.4 *Cessation of Work and Removal of Contractor's Equipment*

After a notice of termination under Sub-Clause 15.5 [Procuring Entity's Entitlement to Termination for Convenience], Sub-Clause 16.2 [Termination by Contractor] or Sub-Clause 19.6 [Optional Termination, Payment and Release] has taken effect, the Contractor shall promptly:

- a) cease all further work, except for such work as may have been instructed by the Architect for the protection of life or property or for the safety of the Works,
- b) hand over Contractor's Documents, Plant, Materials and other work, for which the Contractor has received payment, and
- c) remove all other Goods from the Site, except as necessary for safety, and leave the Site.

16.5 *Payment on Termination*

After a notice of termination under Sub-Clause 16.2 [Termination by Contractor] has taken effect, the Procuring Entity shall promptly:

- a) Return the Performance Security to the Contractor,
- b) pay the Contractor in accordance with Sub-Clause 19.6 [Optional Termination, Payment and Release], and
- c) pay to the Contractor the amount of any loss or damage sustained by the Contractor as a result of this termination.

II *RISK AND RESPONSIBILITY*

17.1 *Indemnities*

17.1 The Contractor shall indemnify and hold harmless the Procuring Entity, the Procuring Entity's Personnel, and their respective agents, against and from all claims, damages, losses and expenses (including legal fees and expenses) in respect of:

- a) Bodily injury, sickness, disease or death, of any person what so ever arising outo for in the course of or by reason of the Contractor's design (if any), the execution and completion of the Works and the remedying of any defects, unless attributable to any negligence, willful actor breach of the Contract by the Procuring Entity, the Procuring Entity's Personnel, or any of their respective agents, and
- b) damage to or loss of any property, real or personal (other than the Works), to the extent that such damage or loss arises out of or in the course of or by reason of the Contractor's design (if any), the execution and completion of the Works and the remedying of any defects, unless and to the extent that any such damage or loss is attributable to any negligence, willful act or breach of the Contract by the Procuring Entity, the Procuring Entity's Personnel, their respective agents, or anyone directly or indirectly employed by any of them.

17.12 The Procuring Entity shall indemnify and hold harmless the Contractor, the Contractor's Personnel, and their respective agents, against and from all claims, damages, losses and expenses (including legal fees and expenses) in respect of (1) bodily injury, sickness, disease or death, which is attributable to any negligence, willful act or breach of the Contract by the Procuring Entity, the Procuring Entity's Personnel, or any of their respective agents, and (2) the matters for which liability may be excluded from insurance cover, as described in sub-paragraphs (d)(i), (ii) and (iii) of Sub-Clause 18.3 [Insurance Against Injury to Persons and Damage to Property], unless and to the extent that any such damage or loss is attributable to

any negligence, willful actor breach of the Contract by the contractor, the contractor's Personnel, their respective agents, or anyone directly or indirectly employed by any of them.

17.2 Contractor's Care of the Works

- 17.21 The Contractor shall take full responsibility for the care of the Works and Goods from the Commencement Date until the Taking-Over Certificate is issued (or is deemed to be issued under Sub-Clause 10.1 [Taking Over of the Works and Sections]) for the Works, when responsibility for the care of the Works shall pass to the Procuring Entity. If a Taking-Over Certificate is issued (or is so deemed to be issued) for any Section or part of the Works, responsibility for the care of the Section or part shall then pass to the Procuring Entity.
- 17.22 After responsibility has accordingly passed to the Procuring Entity, the Contractor shall take responsibility for the care of any work which is outstanding on the date stated in a Taking-Over Certificate, until this outstanding work has been completed.
- 17.23 If any loss or damage happens to the Works, Goods or Contractor's Documents during the period when the Contractor is responsible for their care, from any cause not listed in Sub-Clause 17.3 [Procuring Entity's Risks], the Contractor shall rectify the loss or damage at the Contractor's risk and cost, so that the Works, Goods and Contractor's Documents conform with the Contract.
- 17.24 The Contractor shall be liable for any loss or damage caused by any actions performed by the Contractor after a Taking-Over Certificate has been issued. The Contractor shall also be liable for any loss or damage which occurs after a Taking-Over Certificate has been issued and which arose from a previous event for which the Contractor was liable.

17.3 Procuring Entity's Risks

The risks referred to in Sub-Clause 17.4 [Consequences of Procuring Entity's Risks] below, in so far as they directly affect the execution of the Works in Kenya, are:

- a) War hostilities (whether war be declared or not),
- b) rebellion, riot, commotion or disorder, terrorism, sabotage by persons other than the Contractor's Personnel,
- c) explosive materials, ionizing gradiation or contamination by radio-activity, except as may be attributable to the Contractor's use of such explosives, radiation or radio-activity,
- d) pressure waves caused by aircraft or other aerial devices traveling at sonic or supersonic speeds,
- e) use or occupation by the Procuring Entity of any part of the Permanent Works, except as may be specified in the Contract,
- f) design of any part of the Works by the Procuring Entity's Personnel or by others for whom the Procuring Entity is responsible, and
- g) any operation of the forces of nature which is Unforeseeable or against which an experienced contractor could not reasonably have been expected to have taken adequate preventive precautions.

17.4 Consequences of Procuring Entity's Risks

- 17.4.1 If and to the extent that any of the risks listed in Sub-Clause 17.3 above results in loss or damage to the Works, Goods or Contractor's Documents, the Contractor shall promptly give notice to the Architect and shall rectify this loss or damage to the extent required by the Engineer.
- 17.4.2 If the Contractor suffers delay and/ or incurs Cost from rectifying this loss or damage, the Contractor shall give a further notice to the Architect and shall be entitled subject to Sub-Clause 20.1 [Contractor's Claims] to:
- (a) An extension of time for any such delay, if completion is or will be delayed, under Sub-Clause 8.4 [Extension of Time for Completion], and
 - (b) payment of any such Cost, which shall be included in the Contract Price. In the case of sub-paragraphs (e) and (g) of Sub-Clause 17.3 [Procuring Entity's Risks], Accrued Costs shall be payable.
- 17.4.3 After receiving this further notice, the Architect shall proceed in accordance with Sub-Clause 3.5 [Determinations] to agree or determine these matters.

17.5 Intellectual and Industrial Property Rights

- 17.5.1 In this Sub-Clause, "infringement" shall refer to an infringement (or alleged infringement) of any patent, registered design, copyright, trade mark, trade name, trade secret or other intellectual or industrial property right relating to the Works; and "claim" shall refer to a claim (or proceedings pursuing a claim) alleging an infringement.
- 17.5.2 Whenever a Party does not give notice to the other Party of any claim within 30 days of receiving the claim, the first Party shall be deemed to have waived any right to indemnity under this Sub-Clause.
- 17.5.3 The Procuring Entity shall indemnify and hold the Contractor harmless against and from any claim alleging an infringement which is or was:
- a) An unavoidable result of the Contractor's compliance with the Contract, or
 - b) A result of any Works being ingested by the Procuring Entity:
 - i) for a purpose other than that indicated by, or reasonably to be inferred from, the Contract, or
 - ii) in conjunction with anything not supplied by the Contractor, unless such use was disclosed to the Contractor prior to the Base Date or is stated in the Contract.
- 17.5.4 The Contractor shall indemnify and hold the Procuring Entity harmless against and from any other claim which arises out of or in relation to (i) the manufacture, use, sale or import of any Goods, or (ii) any design for which the Contractor is responsible.
- 17.5.5 If a Party is entitled to be indemnified under this Sub-Clause, the indemnifying Party may (at its cost) conduct negotiations for the settlement of the claim, and any litigation or arbitration which may arise from it. The other Party shall, at the request and cost of the indemnifying Party, assist in contesting the claim. This other Party (and its Personnel) shall not make any admission which might be prejudicial to the indemnifying Party, unless the indemnifying Party failed to take over the conduct of any negotiations, litigation or arbitration upon being requested to do so by such other Party.

1756 For operation and maintenance of any plant or equipment installed, the contractor shall grant a non-exclusive and non-transferable license to the Procuring Entity under the patent, utility models, or other intellectual rights owned by the contractor or a third party from whom the contractor has received the rights to grant sub-licenses and shall also grant to the Procuring Entity a non-exclusive and non-transferable right (without the right to sub-license) to use the know-how and other technical information disclosed to the contractor or under the contract. Nothing contained herein shall be construed as transferring ownership of any patent, utility model, trademark, design, copy right, know-how or other intellectual rights from the contractor or any other third party to the Procuring Entity.

17.6 *Limitation of Liability*

1761 Neither Party shall be liable to the other Party for loss of use of any works, loss of profit, loss of any contractor for any consequential loss or damage which may be suffered by the other Party in connection with the Contract, other than as specifically provided in Sub-Clause 8.7 [Delay Damages]; Sub-Clause 11.2 [Cost of Remedying Defects]; Sub-Clause 15.4 [Payment after Termination]; Sub-Clause 16.4 [Payment on Termination]; Sub-Clause 17.1 [Indemnities]; Sub-Clause 17.4(b) [Consequences of Procuring Entity's Risks] and Sub-Clause 17.5 [Intellectual and Industrial Property Rights].

1762 The total liability of the Contractor to the Procuring Entity, under or in connection with the Contract other than under Sub-Clause 4.19 [Electricity, Water and Gas], Sub-Clause 4.20 [Procuring Entity's Equipment and Free-Issue Materials], Sub-Clause 17.1 [Indemnities] and Sub-Clause 17.5 [Intellectual and Industrial Property Rights], shall not exceed the sum resulting from the application of a multiplier (less or greater than one) to the Accepted Contract Amount, as stated in the **Special Conditions of Contract**, or (if such multiplier or other sum is not so stated) the Accepted Contract Amount.

1763 This Sub-Clause shall not limit liability in any case of fraud, deliberate default or reckless misconduct by the defaulting Party.

17.7 *Use of Procuring Entity's Accommodation/Facilities*

1771 The Contractor shall take full responsibility for the care of the Procuring Entity provided accommodation and facilities, if any, as detailed in the Specification, from the respective dates of hand-over to the Contractor until cessation of occupation (where hand-over or cessation of occupation may take place after the date stated in the Taking-Over Certificate for the Works).

1772 If any loss or damage happens to any of the above items while the Contractor is responsible for their care arising from any cause whatsoever other than those for which the Procuring Entity is liable, the Contractor shall, at his own cost, rectify the loss or damage to the satisfaction of the Engineer.

B *INSURANCE*

18.1 **General Requirements for Insurances**

1811 In this Clause, "insuring Party" means, for each type of insurance, the Party responsible for effecting and maintaining the insurance specified in the relevant Sub-

Clause.

- 18.12 Wherever the Contractor is the insuring Party, each insurance shall be effected with insurers and in terms approved by the Procuring Entity. These terms shall be consistent with any terms agreed by both Parties before the date of the Letter of Acceptance. This agreement of terms shall take precedence over the provisions of this Clause.
- 18.13 Wherever the Procuring Entity is the insuring Party, each insurance shall be effected with insurers and in terms acceptable to the Contractor. These terms shall be consistent with any terms agreed by both Parties before the date of the Letter of Acceptance. This agreement of terms shall take precedence over the provisions of this Clause.
- 18.14 If a policy is required to indemnify joint insured, the cover shall apply separately to each insured as though a separate policy had been issued for each of the joint insured. If a policy indemnifies additional joint insured, namely in addition to the insured specified in this Clause, (i) the Contractor shall act under the policy on behalf of these additional joint insured except that the Procuring Entity shall act for Procuring Entity's Personnel, (ii) additional joint insured shall not be entitled to receive payments directly from the insurer or to have any other direct dealings with the insurer, and (iii) the insuring Party shall require all additional joint insured to comply with the conditions stipulated in the policy.
- 18.15 Each policy insuring against loss or damage shall provide for payments to be made in the currencies required to rectify the loss or damage. Payments received from insurers shall be used for the rectification of the loss or damage.
- 18.16 The relevant insuring Party shall, within the respective periods stated in the **Special Conditions of Contract** (calculated from the Commencement Date), submit to the other Party:
- a) Evidence that the insurances described in this Clause have been affected, and
 - b) copies of the policies for the insurances described in Sub-Clause 18.2 [Insurance for Works and Contractor's Equipment] and Sub-Clause 18.3 [Insurance against Injury to Persons and Damage to Property].
- 18.17 When each premium is paid, the insuring Party shall submit evidence of payment to the other Party. Whenever evidence or policies are submitted, the insuring Party shall also give notice to the Engineer.
- 18.18 Each Party shall comply with the conditions stipulated in each of the insurance policies. The insuring Party shall keep the insurers informed of any relevant changes to the execution of the Works and ensure that insurance is maintained in accordance with this Clause.
- 18.19 Neither Party shall make any material alteration to the terms of any insurance without the prior approval of the other Party. If an insurer makes (or attempts to make) any alteration, the Party first notified by the insurer shall promptly give notice to the other Party.
- 18.20 If the insuring Party fails to effect and keep in force any of the insurances it is required to effect and maintain under the Contractor fails to provide satisfactory evidence

and copies of policies in accordance with this Sub- Clause, the other Party may (at its option and without prejudice to any other right or remedy) effect insurance for the relevant coverage and pay the premiums due. The insuring Party shall pay the amount of these premiums to the other Party, and the Contract Price shall be adjusted accordingly.

- 18.11 Nothing in this Clause limits the obligations, liabilities or responsibilities of the Contractor or the Procuring Entity, under the other terms of the Contractor otherwise. Any amounts not insured or not recovered from the insurers shall be borne by the Contractor and/or the Procuring Entity.
- 18.12 Procuring Entity in accordance with these obligations, liabilities or responsibilities. However, if the insuring Party fails to effect and keep in force an insurance which is available and which it is required to effect and maintain under the Contract, and the other Party neither approves the omission nor effects insurance for the coverage relevant to this default, any moneys which should have been recoverable under this insurance shall be paid by the insuring Party.
- 18.13 Payments by one Party to the other Party shall be subject to Sub-Clause 2.5 [Procuring Entity's Claims] or Sub- Clause 20.1 [Contractor's Claims], as applicable.
- 18.14 The Contractor shall be entitled to place all insurance relating to the Contract (including, but not limited to the insurance referred to Clause 18) with insurers from any eligible source country.

18.2 Insurance for Works and Contractor's Equipment

- 18.21 The insuring Party shall insure the Works, Plant, Material and Contractor's Documents for not less than the full reinstatement cost including the costs of demolition, removal of debris and professional fees and profit. This insurance shall be effective from the date by which the evidence is to be submitted under subparagraph (a) of Sub-Clause 18.1 [General Requirements for Insurances], until the date of issue of the Taking-Over Certificate for the Works.
- 18.22 The insuring Party shall maintain this insurance to provide cover until the date of issue of the Performance Certificate, for loss or damage for which the Contractor is liable arising from a cause occurring prior to the issue of the Taking-Over Certificate, and for loss or damage caused by the Contractor in the course of any other operations (including those under Clause 11 [Defects Liability]).
- 18.23 The insuring Party shall insure the Contractor's Equipment for not less than the full replacement value, including delivery to Site. For each item of Contractor's Equipment, the insurance shall be effective while it is being transported to the Site and until it is no longer required as Contractor's Equipment.
- 18.24 Unless otherwise stated in the Special Conditions, insurances under this Sub-Clause:
- a) Shall be effected and maintained by the Contractor as insuring Party,
 - b) shall be in the joint names of the Parties, who shall be jointly entitled to receive payments from the insurers, payments being held or allocated to the Party actually bearing the costs of rectifying the loss or damage,
 - c) shall cover all loss and damage from any cause not listed in Sub-Clause 17.3 [Procuring Entity's Risks],
 - d) shall also cover, to the extent specifically required in the tendering documents

of the Contract, loss or damage to a part of the Works which is attributable to the use or occupation by the Procuring Entity of another part of the Works, and loss or damage from the risks listed in sub-paragraphs (c), (g) and (h) of Sub-Clause 17.3 [Procuring Entity's Risks], excluding (in each case) risks which are not insurable at commercially reasonable terms, with deductibles per occurrence of not more than the amount stated in the **Special Conditions** of Contract (if an amount is not so stated, this sub-paragraph (d) shall not apply), and

- e) may however exclude loss of, damage to, and reinstatement of:
- i) a part of the Works which is in a defective condition due to a defect in its design, materials or workmanship (but cover shall include any other parts which are lost or damaged as a direct result of this defective condition and not as described in sub-paragraph (ii) below),
 - ii) a part of the Works which is lost or damaged in order to reinstate any other part of the Works if this other part is in a defective condition due to a defect in its design, materials or workmanship,
 - iii) a part of the Works which has been taken over by the Procuring Entity, except to the extent that the Contractor is liable for the loss or damage, and
 - iv) Goods while they are not in Kenya, subject to Sub-Clause 14.5 [Plant and Materials intended for the Works].

18.25 If, more than one year after the Base Date, the cover described in sub-paragraph (d) above ceases to be available at commercially reasonable terms, the Contractor shall (as insuring Party) give notice to the Procuring Entity, with supporting particulars. The Procuring Entity shall then (i) be entitled subject to Sub-Clause 2.5 [Procuring Entity's Claims] to payment of an amount equivalent to such commercially reasonable terms as the Contractor should have expected to have paid for such cover, and (ii) be deemed, unless he obtains the cover at commercially reasonable terms, to have approved the omission under Sub-Clause 18.1 [General Requirements for Insurances].

18.3 *Insurance against Injury to Persons and Damage to Property*

18.31 The insuring Party shall insure against each Party's liability for any loss, damage, death or bodily injury which may occur to any physical property (except things insured under Sub-Clause 18.2 [Insurance for Works and Contractor's Equipment]) or to any person (except persons insured under Sub-Clause 18.4 [Insurance for Contractor's Personnel]), which may arise out of the Contractor's performance of the Contract and occurring before the issue of the Performance Certificate.

18.32 This insurance shall be for a limit per occurrence of not less than the amount stated in the **Special Conditions of Contract**, with no limit on the number of occurrences. If an amount is not stated in the **Special Conditions of Contract**, this Sub-Clause shall not apply.

18.33 Unless otherwise stated in the Special Conditions, the insurances specified in this Sub-Clause:

- a) Shall be effected and maintained by the Contractor as insuring Party,
- b) shall be in the joint names of the Parties,
- c) shall be extended to cover liability for all loss and damage to the Procuring Entity's property (except things insured under Sub-Clause 18.2) arising out of the Contractor's performance of the Contract, and

- d) may however exclude liability to the extent that it arises from:
 - i) the Procuring Entity's right to have the Permanent Works executed on, over, under, in or
 - ii) through any land, and to occupy this land for the Permanent Works,
 - iii) damage which is an unavoidable result of the Contractor's obligations to execute the
 - iv) Works and remedy any defects, and
 - v) a cause listed in Sub-Clause 17.3 [Procuring Entity's Risks], except to the extent that cover is available at commercially reasonable terms.

18.4 Insurance for Contractor's Personnel

- 18.4.1 The Contractor shall effect and maintain insurance against liability for claims, damages, losses and expenses (including legal fees and expenses) arising from injury, sickness, disease or death of any person employed by the Contractor or any other of the Contractor's Personnel.
- 18.4.2 The insurance shall cover the Procuring Entity and the Architect against liability for claims, damages, losses and expenses (including legal fees and expenses) arising from injury, sickness, disease or death of any person employed by the Contractor or any other of the Contractor's Personnel, except that this insurance may exclude losses and claims to the extent that they arise from any act or neglect of the Procuring Entity or of the Procuring Entity's Personnel.
- 18.4.3 The insurance shall be maintained in full force and effect during the whole time that these personnel are assisting in the execution of the Works. For a Subcontractor's employees, the insurance may be effected by the Subcontractor, but the Contractor shall be responsible for compliance with this Clause.

19 FORCE MAJEURE

19.1 Definition of Force Majeure

- 19.1.1 In this Clause, "Force Majeure" means an exceptional event or circumstance:
 - a) Which is beyond a Party's control,
 - b) Which such Party could not reasonably have provided against before entering into the Contract,
 - c) which, having arisen, such Party could not reasonably have avoided or overcome, and
 - d) which is not substantially attributable to the other Party.
- 19.1.2 Force Majeure may include, but is not limited to, exceptional events or circumstances of the kind listed below, so long as conditions (a) to (d) above are satisfied:
 - a) war, hostilities (whether war be declared or not), invasion, act of foreign enemies,
 - b) rebellion, terrorism, sabotage by persons other than the Contractor's Personnel, revolution, insurrection, military or usurped power, or civil war,
 - c) riot, commotion, disorder, strike or lock out by persons other than the Contractor's Personnel,
 - d) munitions of war, explosive materials, ionizing radiation or contamination by radio-activity, except as may be attributable to the Contractor's use of such munitions, explosives, radiation or radio-activity, and

- e) natural catastrophes such as earthquake, hurricane, typhoon or volcanic activity.

19.2 *Notice of Force Majeure*

- 19.21 If a Party is or will be prevented from performing its substantial obligations under the Contract by Force Majeure, then it shall give notice to the other Party of the event or circumstances constituting the Force Majeure and shall specify the obligations, the performance of which is or will be prevented. The notice shall be given within 14 days after the Party became aware, or should have become aware, of the relevant event or circumstance constituting Force Majeure.
- 19.22 The Party shall, having given notice, be excused performance of its obligations for so long as such Force Majeure prevents it from performing them.
- 19.23 Notwithstanding any other provision of this Clause, Force Majeure shall not apply to obligations of either Party to make payments to the other Party under the Contract.

19.3 *Duty to Minimize Delay*

Each Party shall at all times use all reasonable endeavors to minimize any delay in the performance of the Contract as a result of Force Majeure. A Party shall give notice to the other Party when it ceases to be affected by the Force Majeure.

19.4 *Consequences of Force Majeure*

- 19.41 If the Contractor is prevented from performing his substantial obligations under the Contract by Force Majeure of which notice has been given under Sub-Clause 19.2 [Notice of Force Majeure], and suffers delay and/ or incurs Cost by reason of such Force Majeure, the Contractor shall be entitled subject to Sub-Clause 20.1 [Contractor's Claims] to:
 - a) an extension of time for any such delay, if completion is or will be delayed, under Sub-Clause 8.4 [Extension of Time for Completion], and
 - b) if the event or circumstance is of the kind described in sub-paragraphs (i) to (iv) of Sub-Clause 19.1 [Definition of Force Majeure] and, in sub-paragraphs (ii) to (iv), occurs in Kenya, payment of any such Cost, including the costs of rectifying or replacing the Works and/or Goods damaged or destroyed by Force Majeure, to the extent they are not indemnified through the insurance policy referred to in Sub- Clause 18.2 [Insurance for Works and Contractor's Equipment].
- 19.42 After receiving this notice, the Architect shall proceed in accordance with Sub-Clause 3.5 [Determinations] to agree or determine these matters.

19.5 *Force Majeure Affecting Subcontractor*

If any Subcontractor is entitled under any contract or agreement relating to the Works to relief from force majeure on terms additional to or broader than those specified in this Clause, such additional or broader force majeure events or circumstances shall not excuse the Contractor's non-performance or entitle him to relief under this Clause.

19.6 *Optional Termination, Payment and Release*

- 19.61 If the execution of substantially all the Works in progress is prevented for a continuous period of 84 days by reason of Force Majeure of which notice has been given under

Sub-Clause 19.2 [Notice of Force Majeure], or for multiple periods which total more than 140 days due to the same notified Force Majeure, then either Party may give to the other Party a notice of termination of the Contract. In this event, the termination shall take effect 7 days after the notice is given, and the Contractor shall proceed in accordance with Sub-Clause 16.3 [Cessation of Work and Removal of Contractor's Equipment].

- ~~19.6.2~~ Upon such termination, the Architect shall determine the value of the work done and issue a Payment Certificate which shall include:
- a) the amount payable for any work carried out for which a price is stated in the Contract;
 - b) the Cost of Plant and Materials ordered for the Works which have been delivered to the Contractor, or of which the Contractor is liable to accept delivery: this Plant and Materials shall become the property of (and be at the risk of) the Procuring Entity when paid for by the Procuring Entity, and the Contractor shall place the same at the Procuring Entity's disposal;
 - c) other Cost or liabilities which in the circumstances were reasonably and necessarily incurred by the Contractor in the expectation of completing the Works;
 - d) the Cost of removal of Temporary Works and Contractor's Equipment from the Site and the return of these items to the Contractor's works in his country (or to any other destination at no greater cost); and
 - e) the Cost of repatriation of the Contractor's staff and lab or employed wholly in connection with the Works at the date of termination.

19.7 *Release from Performance*

Notwithstanding any other provision of this Clause, if any event or circumstance outside the control of the Parties (including, but not limited to, Force Majeure) arises which makes it impossible or unlawful for either or both Parties to fulfil its or their contractual obligations or which, under the law governing the Contract, entitles the Parties to be released from further performance of the Contract, then upon notice by either Party to the other Party of such event or circumstance:

- a) The Parties shall be discharged from further performance, without prejudice to the rights of either Party in respect of any previous breach of the Contract, and
- b) The sum payable by the Procuring Entity to the Contractor shall be the same as would have been payable under Sub-Clause 19.6 [Optional Termination, Payment and Release] if the Contract had been terminated under Sub-Clause 19.6.

20 SETTLEMENT OF CLAIMS AND DISPUTES

20.1 Contractor's Claims

- 20.1.1** If the Contractor considers itself to be entitled to any extension of the Time for Completion and/or any additional payment, under any Clause of these Conditions or otherwise in connection with the Contract, the Contractor shall give Notice to the Engineer, describing the event or circumstance giving rise to the claim. The notice shall be given as soon as practicable, and not later than 30 days after the Contractor became aware, or should have become aware, of the event or circumstance.
- 20.1.2** If the Contractor fails to give notice of a claim within such period of 30 days, the Time for Completion shall not be extended, the Contractor shall not be entitled to additional payment, and the Procuring Entity shall be discharged from all liability in connection with the claim. Otherwise, the following provisions of this Sub-Clause shall apply.
- 20.1.3** The Contractor shall also submit any other notices which are required by the Contract, and supporting particulars for the claim, all as relevant to such event or circumstance.
- 20.1.4** The Contractor shall keep such contemporary records as may be necessary to substantiate any claim, either on the Site or at an other location acceptable to the Engineer. Without admitting the Procuring Entity's liability, the Architect may, after receiving any notice under this Sub-Clause, monitor the record-keeping and/ or instruct the Contractor to keep further contemporary records. The Contractor shall permit the Architect to inspect all these records and shall (if instructed) submit copies to the Engineer.
- 20.1.5** Within 42 days after the Contractor became aware (or should have become aware) of the event or circumstance giving rise to the claim, or within such other period as may be proposed by the Contractor and approved by the Engineer, the Contractor shall send to the Architect fully detailed claim which includes full supporting particulars of the basis of the claim and of the extension of time and/ or additional payment claimed. If the event or circumstance giving rise to the claim has a continuing effect:
- a) This fully detailed claim shall be considered as interim;
 - b) The Contractor shall send further interim claims at monthly intervals, giving the accumulated delay and/ or amount claimed, and such further particulars as the Architect may reasonably require; and
 - c) The Contractor shall send a final claim within 30 days after the end of the effects resulting from the event or circumstance, or within such other period as may be proposed by the Contractor and approved by the Engineer.
- 20.1.6** Within 42 days after receiving a Notice of a claim or any further particulars supporting a previous claim, or within such other period as may be proposed by the Architect and approved by the Contractor, the Architect shall respond with approval, or with disapproval and detailed comments. He may also request any necessary further particulars but shall nevertheless give his response on the principles of the claim within the above defined time period.

- 2017 Within the above defined period of 42 days, the Architect shall proceed in accordance with Sub-Clause 3.5 [Determinations] to agree or determine (i) the extension (if any) of the Time for Completion (before or after its expiry) in accordance with Sub-Clause 8.4 [Extension of Time for Completion], and/or (ii) the additional payment (if any) to which the Contractor is entitled under the Contract.
- 2018 Each Payment Certificate shall include such additional payment for any claim as has been reasonably substantiated as due under the relevant provision of the Contract. Unless and until the particulars supplied are sufficient to substantiate the whole of the claim, the Contractor shall only be entitled to payment for such part of the claim as he has been able to substantiate.
- 2019 If the Architect does not respond within the time frame defined in this Clause, either Party may consider that the claim is rejected by the Architect and any of the Parties may refer the dispute for amicable settlement in accordance with Clause 20.3.
- 2010 The requirements of this Sub-Clause are in addition to those of any other Sub-Clause which may apply to a claim. If the Contractor fails to comply with this or another Sub-Clause in relation to any claim, any extension of time and/ or additional payment shall take account of the extent (if any) to which the failure has prevented or prejudiced proper investigation of the claim, unless the claim is excluded under the second paragraph of this Sub-Clause 20.3.

20.2 Procuring Entity's Claims

- 2021 If the Procuring Entity considers itself to be entitled to any payment under any Clause of these Conditions or otherwise in connection with the Contract, and/or to any extension of the Defects Notification Period, the Procuring Entity or the Architect shall give notice and particulars to the Contractor. However, notice is not required for payments due under Sub-Clause 4.19 [Electricity, Water and Gas], under Sub-Clause 4.20 [Procuring Entity's Equipment and Free-Issue Materials], or for other services requested by the Contractor.
- 2022 The notice shall be given as soon as practicable and no longer than 30 days after the Procuring Entity became aware, or should have become aware, of the event or circumstances giving rise to the claim. A notice relating to any extension of the Defects Notification Period shall be given before the expiry of such period.
- 2023 The particulars shall specify the Clause or other basis of the claim and shall include substantiation of the amount and/or extension to which the Procuring Entity considers itself to be entitled in connection with the Contract. The Architect shall then proceed in accordance with Sub-Clause 3.5 [Determinations] to agree or determine (i) the amount (if any) which the Procuring Entity is entitled to be paid by the Contractor, and/ or (ii) the extension (if any) of the Defects Notification Period in accordance with Sub-Clause 11.3 [Extension of Defects Notification Period].
- 2024 This amount may be included as a deduction in the Contract Price and Payment Certificates. The Procuring Entity shall only be entitled to set off against or make any deduction from an amount certified in a Payment Certificate, or to otherwise claim against the Contractor, in accordance with this Sub-Clause.

20.3 Amicable Settlement

Where a notice of a claim has been given, both Parties shall attempt to settle the dispute amicably before the commencement of arbitration. However, unless both Parties agree otherwise, the Party giving a notice of a claim in accordance with Sub-Clause 20.1 above should move to commence arbitration after 60 days from the day on which a notice of a claim was given, even if no attempt at an amicable settlement has been made.

20.4 *Matters that may be referred to arbitration*

Notwithstanding anything stated herein the following matters may be referred to arbitration before the practical completion of the Works or abandonment of the Works or termination of the Contract by either party:

- a) Whether or not the issue of an instruction by the Architect is empowered by these Conditions.
- b) Whether or not a certificate has been improperly withheld or is not in accordance with these Conditions.
- c) Any dispute arising in respect risks arising from matters referred to in Clause 17.3 and Clause 19.
- e) All other matters shall only be referred to arbitration after the completion or alleged completion of the Works or termination or alleged termination of the Contract, unless the Procuring Entity and the Contractor agree otherwise in writing.

20.5 *Arbitration*

- 2051 Any claim or dispute between the Parties arising out of or in connection with the Contract not settled amicably in accordance with Sub-Clause 20.3 shall be finally settled by arbitration.
- 2052 No arbitration proceedings shall be commenced on any claim or dispute where notice of a claim or dispute has not been given by the applying party within ninety days of the occurrence or discovery of the matter or issue giving rise to the dispute.
- 2053 Notwithstanding the issue of a notice as stated above, the arbitration of such a claim or dispute shall not commence unless an attempt has in the first instance been made by the parties to settle such claim or dispute amicably with or without the assistance of third parties. Proof of such attempt shall be required.
- 2054 The Arbitrator shall, without prejudice to the generality of his powers, have powers to direct such measurements, computations, tests or valuations as may in his opinion be desirable in order to determine the rights of the parties and assess and award any sums which ought to have been the subject of or included in any certificate.
- 2055 The Arbitrator shall, without prejudice to the generality of his powers, have powers to open up, review and revise any certificate, opinion, decision, requirement or notice and to determine all matters in dispute which shall be submitted to him in the same manner as if no such certificate, opinion, decision require mentor notice had been given.
- 2056 The arbitrators shall have full power to open up, review and revise any certificate, determination, instruction, opinion or valuation of the Engineer, relevant to the dispute. Nothing shall disqualify representatives of the Parties and the Architect from being called as a witness and giving evidence before the arbitrators on any matter

whatsoever relevant to the dispute.

2057 Neither Party shall be limited in the proceedings before the arbitrators to the evidence, or to the reasons for dissatisfaction given in its Notice of Dissatisfaction.

2057 Arbitration may be commenced prior to or after completion of the Works. The obligations of the Parties, and the Architect shall not be altered by reason of any arbitration being conducted during the progress of the Works.

2058 The terms of the remuneration of each or all the members of Arbitration shall be mutually agreed upon by the Parties when agreeing the terms of appointment. Each Party shall be responsible for paying one-half of this remuneration.

20.6 Arbitration with National Contractors

2061 If the Contract is with national contractors, arbitration proceedings will be conducted in accordance with the Arbitration Laws of Kenya. In case of any claim or dispute, such claim or dispute shall be notified in writing by either party to the other with a request to submit it to arbitration and to concur in the appointment of an Arbitrator within thirty days of the notice. The dispute shall be referred to the arbitration and final decision of a person to be agreed between the parties. Failing agreement to concur in the appointment of an Arbitrator, the Arbitrator shall be appointed, on the request of the applying party, by the Chairman or Vice Chairman of any of the following professional institutions;

- i) Architectural Association of Kenya
- ii) Institute of Quantity Surveyors of Kenya
- iii) Association of Consulting Engineers of Kenya
- iv) Chartered Institute of Arbitrators (Kenya Branch)
- v) Institution of Engineers of Kenya

2062 The institution written to first by the aggrieved party shall take precedence over all other institutions.

20.7 Arbitration with Foreign Contractors

207.1 Arbitration with foreign contractors shall be conducted in accordance with the arbitration rules of the United Nations Commission on International Trade Law (UNCITRAL); or with proceedings administered by the International Chamber of Commerce (ICC) and conducted under the ICC Rules of Arbitration; by one or more arbitrators appointed in accordance with said arbitration rules.

207.2 The place of arbitration shall be a location specified in the **SCC**; and the arbitration shall be conducted in the language for communications defined in Sub-Clause 1.4 [Law and Language].

20.8 Alternative Arbitration Proceedings

Alternatively, the Parties may refer the matter to the Nairobi Centre for International Arbitration (NCIA) which offers a neutral venue for the conduct of national and international arbitration with commitment to providing institutional support to the arbitral process.

20.9 Failure to Comply with Arbitrator's Decision

- 209.1 The award of such Arbitrator shall be final and binding up on the parties.
- 209.2 In the even tthat a Party fails to comply with a final and binding Arbitrator's decision, then the other Party may, without prejudice to any other rights it may have, refer the matter to a competent court of law.

20.10 Contract operations to continue

Notwithstanding any reference to arbitration herein,

- 1.1.1 the parties shall continue to perform their respective obligations under the Contract unless they otherwise agree; and
- 1.1.2 the Procuring Entity shall pay the Contractor any monies due the Contractor.

Section IX - Special Conditions of Contract

The following Special Conditions shall supplement the GCC. Whenever there is a conflict, the provisions here in shall prevail over those in the GCC.

Conditions	Sub-Clause	Data
Part A - Contract Data		
Procuring Entity's name and address	Heading	Rural Electrification and Renewable Energy Corporation (REREC)
Name and Reference No. of the Contract	Heading and 1.1	Manda Island 11kv Double Circuit Power Line OCEAN CHANNEL CROSSING & Associated Works (Retender) RFX 1000001366
Engineers Name and address	Heading and 3.1.1	<i>GM Power Distribution and Regional Cordination</i>
Key Personnel names	16.9.1	<i>Dr. Eng. James Muriuki – Project Manager</i>
Time for Completion	1.1.	<u>24 Months</u> from Contract award date. <i>If Sections are to be used, refer to Table: Summary of Sections below</i>
Defects Notification Period	1.1	14 days
Sections	1.1	<i>If Sections are to be used, refer to Table: Summary of Sections below</i>
Electronic transmission systems	1.3	
Time for the Parties entering into a Contract Agreement	1.6	Within 30days
Commencement Date	8.1.1	Immediately after Contract Signing
Time for access to the Site	2.1.1	No later than the Commencement Date, and not later than 14 days after Commencement Date
Architect Duties and Authority	3.1.6 (b) (ii)	Variations resulting in an increase of the Accepted Contract Amount in excess of <u>1</u> % shall require approval of the Procuring Entity. _
Performance Security	4.2.1	The performance security will be in the form of a "performance bond" in the amount(s) of 10% percent of the Accepted Contract Amount and in the same currency(ies) of the Accepted Contract Amount.
Normal working hours	6.5	8:00am – 5:30pm
Delay damages for the Works	8.7 & 14.15(b)	<u>0.25</u> % of the Contract Price per day. <i>If Sections are to be used, refer to Table: Summary of Sections below</i>
Maximum amount of delay damages	8.7.1	<u>10</u> % of the final Contract Price.
Provisional Sums	13.6. (b)(ii)	<i>[If there are Provisional Sums, insert a percentage for adjustment of Provisional Sums]</i> %
Adjustments for Changes in Cost	13.9	Period "n" applicable to the adjustment multiplier "Pn": <u> </u> <i>["not applicable"]</i>
Total advance payment	14.2.1	<u>20</u> % Percentage of the Accepted Contract Amount payable in the currencies and proportions in which the Accepted Contract Amount is payable
Repayment amortization rate of advance payment	14.2.5 (b)	<u>10</u> %

Conditions	Sub-Clause	Data
Percentage of Retention	14.3.2 (c)	5 %
Limit of Retention Money	14.3.2 (c)	5 % of the Accepted Contract Amount
Plant and Materials	14.5.3(b) (i)	If Sub-Clause 14.5 applies: Plant and Materials for payment Free on Board _____ <i>[The Schedules provided by the Contractor under imports].</i>
	14.5.3(c)(i)	Plant and Materials for payment when delivered to the Site _____ <i>[The Schedules provided by the Contractor].</i>
Minimum Amount of Interim Payment Certificates	14.6.2	_____ 15 % of the Accepted Contract Amount.
Publishing source of commercial interest rates for financial charges in case of delayed payment	14.8	Specify 0.0025% rate per month of delayed payment.
Maximum total liability of the Contractor to the Procuring Entity	17.6.2	<i>[Select one of the two options below as appropriate]</i> The product of 0.0025 times the Accepted Contract Amount,
Periods for submission of insurance: a. evidence of insurance. b. relevant policies	18.1.6	_____ 14 _____ days _____ 30 _____ days
Maximum amount of deductibles for insurance of the Procuring Entity's risks	18.2.4 (d)	<i>[3%]</i>
Minimum amount of third-party insurance	18.3.2	<i>[3%]</i>
The place of arbitration	20.7.2	<i>Nairobi, Kenya</i>

SECTION VIII - CONTRACT FORMS

1. FORM No. 1 - NOTIFICATION OF INTENTION TO AWARD
2. FORM NO. 2 – REQUEST FOR REVIEW
3. FORM No. 3-LETTEROF AWARD
4. FORM No. 4 - CONTRACT AGREEMENT
5. FORM No. 5 - PERFORMANCE SECURITY [Option 1 - Unconditional Demand Bank Guarantee]
6. FORM No. 6- PERFORMANCE SECURITY [Option 2– Performance Bond] FORM No. 7 - ADVANCE PAYMENT SECURITY
7. FORM No. 8 - RETENTION MONEY SECURITY

FORM No 1: NOTIFICATION OF INTENTION TO AWARD

[This Notification of Intention to Award shall be sent to each Tenderer that submitted a Tender.]

[Send this Notification to the Tenderer's Authorized Representative named in the Tenderer Information Form]

1) For the attention of Tenderer's Authorized Representative Name:*[insert Authorized Representative's name]*

Address: *[insert Authorized Representative's Address]*

Telephone/Fax numbers: *[insert Authorized Representative's telephone /fax numbers]*

Email Address: *[insert Authorized Representative's email address]*

[IMPORTANT: insert the date that this Notification is transmitted to Tenderers. The Notification must be sent to all Tenderers simultaneously. This means on the same date and as close to the same time as possible.]

DATE OF TRANSMISSION: This Notification is sent by: *[email/fax]* on *[date]* (local time)

Notification of Intention to Award

Procuring Entity:*[insert the name of the Procuring Entity]*

Project:*[insert name of project]*

Contract title:*[insert the name of the contract]*

ITT No: *[insert ITT reference number from Procurement Plan]*

This Notification of Intention to Award (Notification) notifies you of our decision to award the above contract. The transmission of this Notification begins the Standstill Period. During the Standstill Period, you may:

- a) Request a debriefing in relation to the evaluation of your Tender, and/or
- b) Submit a Procurement-related Complaint in relation to the decision to award the contract.

2) The successful Tenderer

Name:	<i>[insert name of successful Tenderer]</i>
Address:	<i>[insert address of the successful Tenderer]</i>
Contract price:	<i>[insert contract price of the successful Tender]</i>

3) Other Tenderers *[INSTRUCTIONS: insert names of all Tenderers that submitted a Tender. If the Tender's price was evaluated include the evaluated price as well as the Tender price as read out.]*

Name of Tenderer	Tender price	Evaluated Tender Cost
<i>[insert name]</i>	<i>[insert Tender price]</i>	<i>[insert evaluated cost]</i>
<i>[insert name]</i>	<i>[insert Tender price]</i>	<i>[insert evaluated cost]</i>

[insert name]	[insert Tender price]	[insert evaluated cost]
[insert name]	[insert Tender price]	[insert evaluated cost]
[insert name]	[insert Tender price]	[insert evaluated cost]

4) Reason/s why your Tender was unsuccessful

[INSTRUCTIONS: State the reasons/why this Tenderer's Tender was unsuccessful. Do NOT include: (a) appoint by point comparison with another Tenderer's Tender, or (b) information that is marked "Confidential" by the Tenderer in its Tender.]

5) How to request a debriefing?

DEADLINE: The deadline to request a debriefing expires at midnight on [insert date] (local time). You may request a debriefing in relation to the results of the evaluation of your Tender. If you decide to request a debriefing, your written request must be made within three (3) Business Days of receipt of this Notification of Intention to Award. Provide the contract name, reference number, name of the Tenderer, contact details; and address the request for debriefing as follows:

Attention:[insert full name of person, if applicable]
Title/position:[insert title/position]
Agency:[insert name of Procuring Entity] Email address:[insert email address]
Fax number:[insert fax number] delete if not used

If your request for a debriefing is received within the 3 Business Days deadline, we will provide the debriefing within five (5) Business Days of receipt of your request. If we are unable to provide the debriefing within this period, the Standstill Period shall be extended by five (5) Business Days after the date that the debriefing is provided. If this happens, we will notify you and confirm the date that the extended Standstill Period will end.

The debriefing may be in writing, by phone, video conference call or in person. We shall promptly advise you in writing how the debriefing will take place and confirm the date and time.

If the deadline to request a debriefing has expired, you may still request a debriefing. In this case, we will provide the debriefing as soon as practicable, and normally no later than fifteen (15) Business Days from the date of publication of the Contract Award Notice.

How to make a complaint*Period: Procurement-related Complaint challenging the decision to award shall be submitted by midnight, [insert date] (local time).*

Provide the contract name, reference number, name of the Tenderer, contact details; and address the Procurement-related Complaint as follows:

Attention:[insert full name of person, if applicable]

Title/position:[insert title/position]

Agency:[insert name of Procuring Entity]

Email address:[insert email address]

Fax number:[insert fax number] delete if not used

At this point in the procurement process, you may submit a Procurement-related Complaint challenging the decision to award the contract. You do not need to have requested, or received, a debriefing before making this complaint. Your complaint must be submitted within the Standstill Period and received by us before the Standstill Period ends.

Further information:

Further information: For more information refer to the Public Procurement and Disposals Act 2015 and its Regulations available from the Website: info@ppra.go.ke or complaints@ppra.go.ke.

In summary, there are four essential requirements:

- 1. You must be an 'interested party'. In this case, that means a Tenderer who submitted a Tender in this Tendering process, and is the recipient of a Notification of Intention to Award.*
- 2. The complaint can only challenge the decision to award the contract.*
- 3. You must submit the complaint within the period stated above.*
- 4. You must include, in your complaint, all of the information required by the Procurement Regulations (as described in Annex III).*

6) Standstill Period

DEADLINE: *The Standstill Period is due to end at midnight on [insert date] (local time).
The Standstill Period lasts ten (10) Business Days after the date of transmission of this Notification of Intention to Award.
The Standstill Period may be extended as stated in Section 4 above.*

If you have any questions regarding this Notification please do not hesitate to contact us. On behalf of the Procuring Entity:

Signature: _____

Name: _____

Title/position: _____

Telephone: _____

Email: _____

FORM NO. 2: REQUEST FOR REVIEW

FORM FOR REVIEW(r.203(1))

PUBLIC PROCUREMENT ADMINISTRATIVE REVIEW BOARD

APPLICATION NO.....OF.....20.....

BETWEEN

.....APPLICANT

AND

.....RESPONDENT (Procuring Entity)

Request for review of the decision of the..... (Name of the Procuring Entity ofdated the...day of20.....in the matter of Tender No.....of20..... for(Tender description).

REQUEST FOR REVIEW

I/We.....,the above named Applicant(s), of address: Physical address.....P. O. Box No..... Tel. No.....Email, hereby request the Public Procurement Administrative Review Board to review the whole/part of the above mentioned decision on the following grounds , namely:

- 1.
- 2.

By this memorandum, the Applicant requests the Board for an order/orders that:

- 1.
- 2.

SIGNED(Applicant) Dated on.....day of/...20.....

FOR OFFICIAL USE ONLY Lodged with the Secretary Public Procurement Administrative Review Board on.....day of20.....

SIGNED

Board Secretary

FORM NO 3: LETTER OF AWARD

To: _____

This is to notify you that your Tender dated _____ for execution of the _____ for the Contract Price in the aggregate of _____, as corrected and modified in accordance with the Instructions to Tenderers is hereby accepted by our Agency.

You are requested to furnish the Performance Security within 28 days in accordance with the Conditions of Contract, using for that purpose one of the Performance Security Forms included in Section X, - Contract Forms, of the Tendering document.

Authorized Signature:

Name and Title of Signatory:

Name of Agency:

Attachment: Contract Agreement:

FORM NO 4: CONTRACT AGREEMENT

THIS AGREEMENT made the day of..... 20....., between.....
.....of..... (hereinafter "the Procuring Entity"), of the one part, and _____ of _____ (hereinafter "the Contractor"), of the other part:

WHEREAS the Procuring Entity desires that the Works known as _____ should be executed by the Contractor, and has accepted a Tender by the Contractor for the execution and completion of these Works and the remedying of any defects there in,

The Procuring Entity and the Contractor agree as follows:

1. In this Agreement words and expressions shall have the same meanings as are respectively assigned to them in the Contract documents referred to.
2. The following documents shall be deemed to form and be read and construed as part of this Agreement. This Agreement shall prevail over all other Contract documents.
 - a) the Notification of Award
 - b) the Form of Tender
 - c) the addenda Nos _____ (if any)
 - d) the Special Conditions of Contract
 - e) the General Conditions of Contract;
 - f) the Specifications
 - g) the Drawings; and
 - h) the completed Schedules and any other documents forming part of the contract.
3. In consideration of the payments to be made by the Procuring Entity to the Contractor as specified in this Agreement, the Contractor here by covenants with the Procuring Entity to execute the Works and to remedy defects therein in conformity in all respects with the provisions of the Contract.
4. The Procuring Entity here by covenants to pay the Contractor in consideration of the execution and completion of the Works and the remedying of defects there in, the Contract Price or such other sum as may become payable under the provisions of the Contract at the times and in the manner prescribed by the Contract.

IN WITNESS where of the parties here to have caused this Agreement to be executed in accordance with the Laws of Kenya on the day, month and year specified above.

Signed and sealed by _____ (for the Procuring Entity)

Signed and sealed by _____ (for the Contractor).

FORM NO. 5 PERFORMANCE SECURITY FORM

OPTION 1 – Demand Bank Guarantee

[Guarantor Form head or SWIFT identifier code]

Beneficiary: _____ *[insert name and Address of Procuring Entity]*

Date: _____ *[Insert date of issue]*

PERFORMANCE GUARANTEE No.: _____ *[Insert guarantee reference number]*

Guarantor: _____ *[Insert name and address of place of issue, unless indicated in the Form head]*

We have been informed that _____ (herein after called “the Applicant”) has entered into Contract No. _____ dated _____ with the Beneficiary, for the execution of _____ (herein after called “the Contract”).

Furthermore, we understand that, according to the conditions of the Contract, a performance guarantee is required.

At the request of the Applicant, we as Guarantor, hereby irrevocably undertake to pay the Beneficiary any sum or sums not exceeding in total an amount of _____ (_____)¹, such sum being payable in the types and proportions of currencies in which the Contract Price is payable, upon receipt by us of the Beneficiary's complying demand supported by the Beneficiary's statement, whether in the demand itself or in a separate signed document accompanying or identifying the demand, stating that the Applicant is in breach of its obligation (s) under the Contract, without the Beneficiary needing to prove or to show grounds for your demand or the sum specified there in.

This guarantee shall be reduced by half upon our receipt of:

- a) A copy of the Operational Acceptance Certificate; or
- b) a registered Form from the Applicant (i) attaching a copy of its notice requesting issuance of the Operational Acceptance Certificate and (ii) stating that the Project Manager has failed to issue such Certificate within the time required or provide in writing justifiable reasons why such Certificate has not been issued, so that Operational Acceptance is deemed to have occurred.

This guarantee shall expire no later than the earlier of:²

- a) twelve months after our receipt of either (a) or (b) above; or
- b) eighteen months after our receipt of:
 - i) a copy of the Completion Certificate; or
 - ii) a registered Form from the Applicant, attaching a copy of the notice to the Project Manager that the Facilities are ready for commissioning, and stating that fourteen days have elapsed from receipt of such notice (or seven days have elapsed if the notice was a repeated notice) and the Project Manager has failed to issue a Completion Certificate or in form the Applicant in writing of any defects or deficiencies; or
 - iii) a registered Form from the Applicant stating that no Completion Certificate has been issued but the Procuring Entity is making use of the Facilities; or

c) the ____ day of ____, 2__

Consequently, any demand for payment under this guarantee must be received by us at this office on or before that date.

¹*The Guarantor shall insert an amount representing the percentage of the Contract Price specified in the Contract and denominated either in the currency(ies)*

of the Contract or a freely convertible currency acceptable to the Procuring Entity.

²*This text shall be revised as and where necessary to take into account (i) partial acceptance of the Facilities in accordance with Sub-Clause 25.4 of the GCC; and*

(ii) extension of the Performance Security when the Contractor is liable for an extended warranty obligation pursuant to Sub-Clause 27.10 of the GCC (although in this latter case the Procuring Entity might want to consider an extended warranty security in lieu of the extension of the Performance Security).

This guarantee is subject to the Uniform Rules for Demand Guarantees (URDG) 2010 Revision, ICC Publication No.758, except that the supporting statement under Article 15 (a) is hereby excluded.

[signature(s)]

Note: *All italicized text (including footnotes) is for use in preparing this form and shall be deleted from the final product.*

³*Insert the date twenty-eight days after the expected expiration date of the Defect Liability Period. The Procuring Entity should note that in the event of an extension of the time for completion of the Contract, the Procuring Entity would need to request an extension of this guarantee from the Guarantor. Such request must be in writing and must be made prior to the expiration date established in the guarantee. In preparing this guarantee, the Procuring Entity might consider adding the following text to the form, at the end of the pen ultimate paragraph: "The Guarantor agrees to a one-time extension of this guarantee for a period not to exceed [six months] [one year], in response to the Procuring Entity's written request for such extension, such request to be presented to the Guarantor before the expiry of the guarantee."*

FORM No. 6- PERFORMANCE SECURITY OPTION 2 – (Performance Bond)

[Note: Procuring Entities are advised to use Performance Security–Unconditional Demand Bank Guarantee instead of Performance Bond due to difficulties involved in calling Bond holder to action]

[Guarantor Form head or SWIFT identifier code]

Beneficiary: _____ *[insert name and Address of Procuring Entity]*

Date: _____ *[Insert date of issue]*

PERFORMANCE BOND No.: _____

Guarantor: _____ *[Insert name and address of place of issue, unless indicated in the Form head]*

1. By this Bond _____ as Principal (herein after called “the Contractor”) and _____] as Surety (herein after called “the Surety”), are held and firmly bound unto _____] as Obligated (herein after called “the Procuring Entity”) in the amount of ___ for the payment of which sum well and truly to be made in the types and proportions of currencies in which the Contract Price is payable, the Contractor and the Surety bind themselves, their heirs, executors, administrators, successors and assigns, jointly and severally, firmly by these presents.
2. WHEREAS the Contractor has entered in to a written Agreement with the Procuring Entity dated the day of, 20, for _____ in accordance with the documents, plans, specifications, and amendments there to, which to the extent herein provided for, are by reference m a depart here of and are herein after referred to as the Contract.
3. NOW, THEREFORE, the Condition of this Obligation is such that, if the Contractor shall promptly and faithfully perform the said Contract (including any amendments there to), then this obligation shall be null and void; otherwise, it shall remain in full force and effect. Whenever the Contractor shall be, and declared by the Procuring Entity to be, in default under the Contract, the Procuring Entity having performed the Procuring Entity's obligations there under, the Surety may promptly remedy the default, or shall promptly:
 - 1) Complete the Contract in accordance with its terms and conditions; or
 - 2) Obtain a tender or tenders from qualified tenderers for submission to the Procuring Entity for completing the Contract in accordance with its terms and conditions, and upon determination by the Procuring Entity and the Surety of the lowest responsive Tenderers, arrange for a Contract between such Tenderer, and Procuring Entity and make available as work progresses (even though there should be a default or a succession of defaults under the Contract or Contracts of completion arranged under this paragraph) sufficient funds to pay the cost of completion less the Balance of the Contract Price; but not exceeding, including other costs and damages for which the Surety may be liable here under, the amount set for thin the first paragraph hereof. The term “Balance of the Contract Price,” as used in this paragraph, shall mean the total amount payable by Procuring Entity to Contractor under the Contract, less the amount properly paid by Procuring Entity to Contractor; or
 - 3) Pay the Procuring Entity the amount required by Procuring Entity to complete the Contract in accordance with its terms and conditions up to a total not exceeding the amount of this Bond.
4. The Surety shall not be liable for a greater sum than the specified penalty of this Bond.

5. Any suit under this Bond must be instituted before the expiration of one year from the date of the issuing of the Taking-Over Certificate. No right of action shall accrue on this Bond to or for the use of any person or corporation other than the Procuring Entity named here in or the heirs, executors, administrators, successors, and assigns of the Procuring Entity.
6. In testimony whereof, the Contractor has hereunto set his hand and affixed his seal, and the Surety has caused these presents to be sealed with his corporate seal duly attested by the signature of his legal representative, this day_of _____ 20 _____. SIGNED ON ___ on behalf of

By _____ in the capacity

of in the presence of

SIGNED ON _____ on behalf of

By _____ in the capacity

of in the presence of

FORM NO. 7 ADVANCE PAYMENT SECURITY - Demand Bank Guarantee

[Guarantor Form head or SWIFT identifier code]

Beneficiary: _____ *[Name and Address of Procuring Entity]*

Date: _____ *[Insert date of issue]*

Advance Payment Guarantee No.: _____ *[Insert guarantee reference number]*

Guarantor: _____ *[Insert name and address of place of issue, unless indicated in the Form head]*

We have been informed that _____ (herein after called "the Applicant") has entered into Contract No. _____ dated _____ with the Beneficiary, for the execution of, _____ (herein after called "the Contract").

Furthermore, we understand that, according to the Conditions of the Contract, an advance payment in the sum _____ (_____) is to be made against an advance payment guarantee.

At the request of the Applicant, we as Guarantor, hereby irrevocably undertake to pay the Beneficiary any sum or sums not exceeding in total an amount of (_____)⁴ upon receipt by us of the Beneficiary's complying demand supported by the Beneficiary's statement whether in the demand itself or in a separate signed document accompanying or identifying the demand, stating either that the applicant:

- a) Has used the advance payment for purposes other than the costs of mobilization in respect of the Facilities; or
- b) has failed to repay the advance payment in accordance with the Contract conditions, specifying the amount which the Applicant has failed to repay.

A demand under this guarantee may be presented as from the presentation to the Guarantor of a certificate from the Beneficiary's bank stating that the advance payment referred to above has been credited to the Applicant on its account number _____ at.

The maximum amount of this guarantee shall be progressively reduced by the amount of the advance payment repaid by the Applicant as indicated in copies of interim statements or payment certificates which shall be presented to us. This guarantee shall expire, at the latest, upon our receipt of documentation indicating full repayment by the Applicant of the amount of the advance payment, or on the _____ day of _____, _____⁵, whichever is earlier. Consequently, any demand for payment under this guarantee must be received by us at this office on or before that date.

This guarantee is subject to the Uniform Rules for Demand Guarantees (URDG) 2010 Revision, ICC Publication No. 758, except that the supporting statement under Article 15 (a) is hereby excluded.

[signature(s)]

⁴The Guarantor shall insert an amount representing the amount of the advance payment and denominated either in the currency(ies) of the advance payment as specified in the Contract, or in a freely convertible currency acceptable to the Procuring Entity.

⁵Insert the expected expiration date of the Time for Completion. The Procuring Entity should note that in the event of an extension of the time for completion of the Contract, the Procuring Entity would need to request an extension of this guarantee from the Guarantor. Such request must be in writing and must be made prior to the expiration date established in the guarantee. In preparing this guarantee, the Procuring Entity might consider adding the following text to the form, at the end of the penultimate paragraph: "The Guarantor agrees to a one-time extension of this guarantee for a period not to exceed [six months] [one year], in response to the Beneficiary's written request for such extension, such request to be presented to the Guarantor before the expiry of the guarantee."

FORM NO. 8 – RETENTION MONEY SECURITY

[Demand Bank Guarantee]

[Guarantor letterhead]

Beneficiary: _____ *[Insert name and Address of Procuring Entity]*

Date: _____ *[Insert date of issue]*

Advance payment guarantee no. *[Insert guarantee reference number]*

Guarantor: *[Insert name and address of place of issue, unless indicated in the letterhead]*

1. We have been informed that _____ *[insert name of Contractor, which in the case of a joint venture shall be the name of the joint venture]* (hereinafter called "the Contractor") has entered into Contract No. _____ *[insert reference number of the contract]* dated _____ with the Beneficiary, for the execution of _____ *[insert name of contract and brief description of Works]* (hereinafter called "the Contract").
2. Furthermore, we understand that, according to the conditions of the Contract, the Beneficiary retains moneys upto the limit set forth in the Contract ("the Retention Money"), and that when the Taking-Over Certificate has been issued under the Contract and the first half of the Retention Money has been certified for payment, and payment of *[insert the second half of the Retention Money]* is to be made against a Retention Money guarantee.
3. At the request of the Contractor, we, as Guarantor, hereby irrevocably undertake to pay the Beneficiary any sum or sums not exceeding in total an amount of *[insert amount in figures]* _____ (*[insert amount in words* _____ *]*)¹ upon receipt by us of the Beneficiary's complying demands supported by the Beneficiary's statement, whether in the demand itself or in a separate signed document accompanying or identifying the demand, stating that the Contractor is in breach of its obligation(s) under the Contract, without your needing to prove or show grounds for your demand or the sum specified there in.
4. A demand under this guarantee may be presented as from the presentation to the Guarantor of a certificate from the Beneficiary's bank stating that the second half of the Retention Money as referred to above has been credited to the Contractor on its account number _____ at *[insert name and address of Applicant's bank]*.
5. This guarantee shall expire no later than the.....Day of.....², and any demand for payment under it must be received by us at the office indicated above on or before that date.
6. The Guarantor agrees to a one-time extension of this guarantee for a period not to exceed *[six months]* *[one year]*, in response to the Beneficiary's written request for such extension, such request to be presented to the Guarantor before the expiry of the guarantee.

[Name of Authorized Official, signature(s) and seals/stamps]

¹ The Guarantor shall insert an amount representing the amount of the second half of the Retention Money.

² Insert a date that is twenty-eight days after the expiry of retention period after the actual completion date of the contract. The Procuring Entity should note that in the event of an extension of this date for completion of the Contract, the Procuring Entity would need to request an extension of this guarantee from the Guarantor. Such request must be in writing and must be made prior to the expiration date established in the guarantee.

FORM NO. 9 BENEFICIAL OWNERSHIP DISCLOSURE FORM
(Amended and issued pursuant to PPRA CIRCULAR No. 02/2022)

INSTRUCTIONS TO TENDERERS: DELETE THIS BOX ONCE YOU HAVE COMPLETED THE FORM

This Beneficial Ownership Disclosure Form ("Form") is to be completed by the successful tenderer pursuant to Regulation 13 (2A) and 13 (6) of the Companies (Beneficial Ownership Information) Regulations, 2020. In case of joint venture, the tenderer must submit a separate Form for each member. The beneficial ownership information to be submitted in this Form shall be current as of the date of its submission.

For the purposes of this Form, a Beneficial Owner of a Tenderer is any natural person who ultimately owns or controls the legal person (tenderer) or arrangements or a natural person on whose behalf a transaction is conducted, and includes those persons who exercise ultimate effective control over a legal person (Tenderer) or arrangement.

Tender Reference No.: _____ [*insert identification no*] Name of the Tender Title/Description: _____ [*insert name of the assignment*] to: _____ [*insert complete name of Procuring Entity*]

In response to the requirement in your notification of award dated _____ [*insert date of notification of award*] to furnish additional information on beneficial ownership: _____ [*select one option as applicable and delete the options that are not applicable*]

1) We here by provide the following beneficial ownership information.

Details of beneficial ownership

Details of all Beneficial Owners		% of shares a person holds in the company Directly or indirectly	% of voting rights a person holds in the company	Whether a person directly or indirectly holds a right to appoint or remove a member of the board of directors of the company or an equivalent governing body of the Tenderer (Yes / No)	Whether a person directly or indirectly exercises significant influence or control over the Company (tenderer) (Yes / No)
1.	Full Name	Directly----- ----- % of shares	Directly.....% of voting rights	1. Having the right to appoint a majority of the board of the directors or an equivalent governing body of the Tenderer: Yes -----No----	1. Exercises significant influence or control over the Company body of the Company (tenderer) Yes -----No---
	National identity card number or Passport number				
	Personal Identification Number (where applicable)	Indirectly---- ----- % of shares	Indirectly----- % of voting rights	2. Is this right held directly or indirectly?: Direct..... Indirect.....	2. Is this influence or control exercised directly or indirectly?
	Nationality				
	Date of birth [dd/mm/yyyy]				
	Postal address				
	Residential address				
	Telephone				

Details of all Beneficial Owners		% of shares a person holds in the company Directly or indirectly	% of voting rights a person holds in the company	Whether a person directly or indirectly holds a right to appoint or remove a member of the board of directors of the company or an equivalent governing body of the Tenderer (Yes / No)	Whether a person directly or indirectly exercises significant influence or control over the Company (tenderer) (Yes / No)
	number				Direct..... Indirect..... ...
	Email address				
	Occupation or profession				
2.	Full Name		Directly----- ----- % of shares	Directly.....% of voting rights	1. Having the right to appoint a majority of the board of the directors or an equivalent governing body of the Tenderer: Yes ----No---- 2. Is this right held directly or indirectly?: Direct..... Indirect..... Direct..... Indirect.....
	National identity card number or Passport number				
	Personal Identification Number (where applicable)		Indirectly---- ----- % of shares	Indirectly----- % of voting rights	
	Nationality(ies)				
	Date of birth [dd/mm/yyyy]				
	Postal address				
	Residential address				
	Telephone number				
	Email address				
Occupation or profession					
3. e.t .c					

II) Am fully aware that beneficial ownership information above shall be reported to the Public Procurement Regulatory Authority together with other details in relation to contract awards and shall be maintained in the Government Portal, published and made publicly available pursuant to Regulation 13(5) of the Companies (Beneficial Ownership Information) Regulations, 2020. (Notwithstanding this paragraph Personally Identifiable Information in line with the Data Protection Act shall not be published or made public). *Note that Personally*

Identifiable Information (PII) is defined as any information that can be used to distinguish one person from another and can be used to deanonymize previously anonymous data. This information includes National identity card number or Passport number, Personal Identification Number, Date of birth, Residential address, email address and Telephone number.

III) In determining who meets the threshold of who a beneficial owner is, the Tenderer must consider a natural person who in relation to the company:

- (a) holds at least ten percent of the issued shares in the company either directly or indirectly;
- (b) exercises at least ten percent of the voting rights in the company either directly or indirectly;
- (c) holds a right, directly or indirectly, to appoint or remove a director of the company; or
- (d) exercises significant influence or control, directly or indirectly, over the company.

IV) What is stated to herein above is true to the best of my knowledge, information and belief.

*Name of the Tenderer: * [insert complete name of the Tenderer]*

*Name of the person duly authorized to sign the Tender on behalf of the Tenderer: ** [insert complete name of person duly authorized to sign the Tender]*

Designation of the person signing the Tender: [insert complete title of the person signing the Tender]

Signature of the person named above: [insert signature of person whose name and capacity are shown above]

Date this [insert date of signing] day of..... [Insert month], [insert year]

Bidder Official Stamp