



**NATIONAL GOVERNMENT CONSTITUENCY
DEVELOPMENT FUND**

CHESUMEI CONSTITUENCY

TENDER DOCUMENT

FOR

**PROPOSED CONSTRUCTION OF ONE STOREY TUITION BLOCK OF 8
NO. CLASSROOMS AT KOMBE DAY SENIOR SCHHOL**

TENDER NO. NG-CDF/CHESUMEI/KOMBE/002/2025-2026

OPEN TENDER

JUNE, 2026

FUND ACCOUNT MANAGER

CHESUMEI CONSTITUENCY

NATIONAL GOVERNMENT CONSTITUENCY
DEVELOPMENT FUND

P. O. BOX 40 – 30300 KAPSABET

TABLE OF CONTENTS

INVITATION TO TENDER.....	V
APPENDIX TO THE PREFACE.....	vii
GUIDELINES FOR PREPARATION OF TENDER DOCUMENTS.....	vii
2. PART 1 - TENDERING PROCEDURES.....	vii
3. PART 2 - PROCUREMENT ENTITY'S REQUIREMENTS.....	vii
4. PART 3 - CONDITIONS OF CONTRACT AND CONTRACT FORMS.....	viii
INVITATION TO TENDER.....	X
<u>SECTION I - INSTRUCTIONS TO TENDERERS</u>	1
A. General Provisions	1
1. Scope of Tender.....	1
2. Fraud and Corruption.....	1
3. Eligible Tenderers.....	1
4. Eligible Goods, Equipment, and Services.....	3
5. Tenderer's Responsibilities.....	3
B. Contents of Tender Documents	3
6. Sections of Tender Document.....	3
7. Site visit.....	4
8. Pre-Tender Meeting.....	4
9. Clarification and amendment of Tender Documents.....	5
10. Amendment of Tender Documents.....	5
C. Preparation of Tenders	5
11. Cost of Tendering.....	5
12. Language of Tender.....	5
13. Documents Comprising the Tender.....	5
14. Form of Tender and Schedules.....	6
15. Alternative Tenders.....	6
16. Tender Prices and Discounts.....	6
17. Currencies of Tender and Payment.....	7
18. Documents Comprising the Technical Proposal.....	7
19. Documents Establishing the Eligibility and Qualifications of the Tenderer	
20. Period of Validity of Tenders.....	8
21. Tender Security.....	8
22. Format and Signing of Tender.....	9
D. Sealing and Marking of Tenders	9
23. Sealing and Marking of Tenders.....	9
24. Deadline for Submission of Tenders.....	10
25. Late Tenders.....	10
26. Withdrawal, Substitution, and Modification of Tenders.....	10
27. Tender Opening.....	10
E. Evaluation and Comparison of Tenders	11
28. Confidentiality.....	11
29. Clarification of Tenders.....	11
30. Deviations, Reservations, and Omissions.....	12
31. Determination of Responsiveness.....	12
32. Non-material Non-conformities.....	12
33. Arithmetical Errors.....	12
34. Conversion to Single Currency.....	13
35. Margin of Preference and Reservations.....	13

36.	Subcontractors.....	13
37.	Evaluation of Tenders.....	13
38.	Comparison of Tenders.....	14
39.	Abnormally Low Tenders.....	14
40.	Abnormally High Tenders.....	14
41.	Unbalanced and/or Front-Loaded Tenders.....	14
42.	Qualifications of the Tenderer.....	15
43.	Best Evaluated Tender.....	15
44.	Procuring Entity's Right to Accept Any Tender, and to Reject Any or All Tenders.....	15
F.	Award of Contract.....	15
45.	Award Criteria.....	15
46.	Notice of Intention to enter into a Contract.....	15
47.	Standstill Period.....	16
48.	Debriefing by the Procuring Entity.....	16
49.	Letter of Award.....	16
50.	Signing of Contract.....	16
51.	Appointment of Adjudicator.....	16
52.	Performance Security.....	16
53.	Publication of Procurement Contract.....	17
53.	Procurement Related Complaints.....	17
	SECTION II-TENDER DATA SHEET(TDS).....	18
	SECTION III - EVALUATION AND QUALIFY ON CRITERIA.....	23
1.	General Provisions.....	23
2.	Preliminary examination for Determination of Responsiveness.....	23
3.	Tender Evaluation (ITT 35).....	23
4.	Multiple Contracts.....	23
5.	Alternative Tenders (ITT 13.1).....	24
6.	Margin of Preference is not applicable.....	24
7.	Post qualification and Contract award (ITT 39), more specifically.....	24
	SECTION IV – TENDERING FORMS.....	25
	QUALIFICATION FORMS.....	28
1.	Form Equ. Equipment.....	28
2.	Form per-1.....	29
4.	FORM PER-2.....	30
5.	TENDERERS QUALIFICATION WITHOUT PRE-QUALIFICATION.....	32
	FORM ELI -1.1.....	32
	FORM ELI -1.2.....	33
	FORM CON – 2.....	34
5.4	FORM FIN – 3.1.....	36
5.5	FORM FIN – 3.2.....	37
5.6	FORM FIN – 3.3.....	38
5.7	FORM FIN – 3.4.....	38
5.8	FORM EXP - 4.1.....	39
5.9	FORM EXP - 4.2(a).....	40
5.11	FORM EXP - 4.2(b).....	41
	OTHER FORMS.....	42
6.	FORM OF TENDER.....	42
a)	TENDERER'S ELIGIBILITY- CONFIDENTIAL BUSINESS QUESTIONNAIRE.....	45
b)	CERTIFICATE OF INDEPENDENT TENDER DETERMINATION.....	48

c)	SELF-DECLARATION FORM - SELF DECLARATION OF THE TENDERER.....	49
d)	APPENDIX 1- FRAUD AND CORRUPTION.....	52
7.	FORM OF TENDER SECURITY - DEMAND BANK GUARANTEE.....	54
8.	FORM OF TENDER SECURITY (INSURANCE GUARANTEE).....	55
9.	FORM OF TENDER-SECURING DECLARATION.....	56
10.	APPENDIX TO TENDER.....	57
PART II - WORK REQUIREMENTS.....		58
SECTION V - DRAWINGS.....		58
SECTION VI - SPECIFICATIONS.....		58
SECTION VII - BILLS OF QUANTITIES.....		59
1.	Objectives.....	59
2.	Day work Schedule.....	59
3.	Provisional Sums.....	59
4.	The Bills of Quantities.....	59
PART III-CONDITIONS OF CONTRACT AND CONTRACT FORMS.....		60
SECTION VIII - GENERAL CONDITIONS OF CONTRACT.....		60
A. General		
1.	Definitions.....	61
2.	Interpretation.....	61
3.	Language and Law.....	62
4.	Project Manager's Decisions.....	63
5.	Delegation.....	63
6.	Communications.....	63
7.	Subcontracting.....	63
8.	Other Contractors.....	63
9.	Personnel and Equipment.....	63
10.	Procuring Entity's and Contractor's Risks.....	63
11.	Procuring Entity's Risks.....	63
12.	Contractor's Risks.....	64
13.	Insurance.....	64
14.	Site Data.....	64
15.	Contractor to Construct the Works.....	64
16.	The Works to Be Completed by the Intended Completion Date.....	64
17.	Approval by the Project Manager.....	64
18.	Safety.....	65
19.	Discoveries.....	65
20.	Possession of the Site.....	65
21.	Access to the Site.....	65
22.	Instructions, Inspections and Audits.....	65
23.	Appointment of the Adjudicator.....	65
24.	Settlement of Claims and Disputes.....	66
25.	Fraud and Corruption.....	68
B. Time Control.....		
1.	Program.....	68
2.	Extension of the Intended Completion Date.....	69
3.	Acceleration.....	69
4.	Delays Ordered by the Project Manager.....	69
5.	Management Meetings.....	69
6.	Early Warning.....	70

C.	Quality Control.....	69
1.	Identifying Defects.....	69
2.	Tests.....	69
3.	Correction of Defects.....	69
4.	Uncorrected Defects.....	69
D.	Cost Control.....	70
1.	Contract Price.....	70
2.	Changes in the Contract Price.....	70
3.	Variations.....	71
4.	Cash Flow Forecasts.....	72
5.	Payment Certificates.....	72
6.	Payments.....	72
7.	Compensation Events.....	73
8.	Tax.....	73
9.	Currency of Payment.....	73
10.	Price Adjustment.....	73
11.	Retention.....	74
12.	Liquidated Damages.....	74
13.	Bonus.....	74
14.	Advance Payment.....	74
15.	Securities.....	75
16.	Dayworks.....	75
17.	Cost of Repairs.....	75
E.	Finishing the Contract.....	75
1.	Completion.....	75
2.	Taking Over.....	75
3.	Final Account.....	75
4.	Operating and Maintenance Manuals.....	75
5.	Termination.....	76
6.	Payment upon Termination.....	76
7.	Property.....	76
8.	Release from Performance.....	76
	SECTION IX - SPECIAL CONDITIONS OF CONTRACT.....	77
	SECTION X - CONTRACT FORMS.....	88
	FORM No. 1 - NOTIFICATION OF INTENTION TO AWARD.....	80
	FORM No. 2 – REQUEST FOR REVIEW.....	83
	FORM No. 3 - LETTER OF AWARD.....	83
	FORM No. 4 - CONTRACT AGREEMENT.....	84
	FORM No. 5 - PERFORMANCE SECURITY [Option 1 - Unconditional Demand Bank Guarantee].....	85
	FORM No. 6- PERFORMANCE SECURITY [Option 2– Performance Bond].....	86
	FORM No. 7- ADVANCE PAYMENT SECURITY.....	88
	FORM No. 8- RETENTION MONEY SECURITY.....	87
	FORM No. 9- BENEFICIAL OWNERSHIP DISCLOSURE FORM.....	87

INVITATION TO TENDER

NG-CDF CHESUMEI CONSTITUENCY,
P.O. Box 40-30300,
KAPSABET.

TENDER NO. NG-CDF/CHESUMEI/KOMBE/002/2025-2026

TENDER NAME: Proposed Construction of one storey Tuition Block of 8 no classrooms at Kombe Day senior school.

The National Government Constituency Development Fund-Chesumei Constituency invites bids from eligible bidders for Proposed Construction of Digital Hub at Deputy County Commissioner Office-Chesumei Office.

1. This Tender is **Open**
2. Qualified and interested tenderers may obtain further information and inspect the Tender Documents at NG-CDF Offices, Chesumei Constituency during office hours [0900 to 1500 hours] at the address given below.
3. A complete set of tender documents may be downloaded from the Chesumei NG-CDF website www.tenders.go.ke.
4. Tender documents may be obtained electronically from www.tenders.go.ke. Tender documents obtained electronically will be free of charge.
5. Tender documents may be viewed and downloaded for free from the website www.tenders.go.ke.
6. Tenders shall be quoted be in Kenya Shillings and shall include all taxes. Tenders shall remain valid for 259 days from the date of opening of tenders.
7. This tender must be accompanied by a **Tender securing declaration form**
8. The Tenderer MUST chronologically serialize all pages of the tender documents submitted in the order of 1,2,3, 4, ...
9. Completed tenders must be delivered to the address below so as to be received on or before **29th June,2026 at 2:00 P.M.** Bids submitted after this prescribed time shall be rejected.
10. Tenders will be opened immediately after the deadline date and time specified above or any deadline date and time specified later. Tenders will be publicly opened in the presence of the Tenderers' designated representatives who choose to attend at the address below.
11. Late tenders will be rejected

The address referred to above are:

A. Address for obtaining further information and for purchasing tender documents

Fund Account Manager,
National Government Constituency Development Fund,
Chesumei Constituency,
P.O. Box 40-30300, Kapsabet.

B. Address for Submission of Tenders. (Office or Tender Box)

Physical address for hand Courier Delivery to office or Tender Box

Fund Account Manager,
National Government Constituency Development Fund,
Chesumei Constituency,
P.O. Box 40-30300,
Kapsabet.

C. Address for Opening of Tenders.

Fund Account Manager,
National Government Constituency Development Fund,
Chesumei Constituency,
P.O. Box 40-30300,
Kapsabet.

PART 1 - TENDERING PROCEDURES

SECTION I: INSTRUCTIONS TO TENDERERS

A General Provisions

1. Scope of Tender

- 1.1 The Procuring Entity as defined in the Appendix to Conditions of Contract invites tenders for Works Contract as described in the tender documents. The name, identification, and number of lots (contracts) of this Tender Document are **specified in the TDS**.

2. Fraud and Corruption

- 2.1 The Procuring Entity requires compliance with the provisions of the Public Procurement and Asset Disposal Act, 2015, Section 62 “Declaration not to engage in corruption”. The tender submitted by a person shall include a declaration that the person shall not engage in any corrupt or fraudulent practice and a declaration that the person or his or her sub-contractors are not debarred from participating in public procurement proceedings.
- 2.2 The Procuring Entity requires compliance with the provisions of the Competition Act 2010, regarding collusive practices in contracting. Any tenderer found to have engaged in collusive conduct shall be disqualified and criminal and/or civil sanctions may be imposed. To this effect, Tenders shall be required to complete and sign the “Certificate of Independent Tender Determination” annexed to the Form of Tender.
- 2.3 Unfair Competitive Advantage - Fairness and transparency in the tender process require that the firms or their Affiliates competing for a specific assignment do not derive a competitive advantage from having provided consulting services related to this tender. To that end, the Procuring Entity shall indicate in the **Data Sheet** and make available to all the firms together with this tender document all information that would in that respect give such firm any unfair competitive advantage over competing firms.
- 2.4 Unfair Competitive Advantage -Fairness and transparency in the tender process require that the Firms or their Affiliates competing for a specific assignment do not derive a competitive advantage from having provided consulting services related to this tender being tendered for. The Procuring Entity shall indicate in the **TDS** firms (if any) that provided consulting services for the contract being tendered for. The Procuring Entity shall check whether the owners or controllers of the Tenderer are same as those that provided consulting services. The Procuring Entity shall, upon request, make available to any tenderer information that would give such firm unfair competitive advantage over competing firms.

3. Eligible Tenderers

- 3.1 A Tenderer may be a firm that is a private entity, a state-owned enterprise or institution subject to ITT 3.7 or any combination of such entities in the form of a joint venture (JV) under an existing agreement or with the intent to enter into such an agreement supported by a letter of intent. Public employees and their close relatives (*wives, children, brothers, sisters and uncles and aunts*) are not eligible to participate in the tender. In the case of a joint venture, all members shall be jointly and severally liable for the execution of the entire Contract in accordance with the Contract terms. The JV shall nominate a Representative who shall have the authority to conduct all business for and on behalf of any and all the members of the JV during the tendering process and, in the event the JV is awarded the Contract, during contract execution. The maximum number of JV members shall be specified in the **TDS**.
- 3.2 Public Officers of the Procuring Entity, their Spouses, Child, Parent, Brothers or Sister. Child, Parent, Brother or Sister of a Spouse, their business associates or agents and firms/organizations in which they have a substantial or controlling interest shall not be eligible to tender or be awarded a contract. Public Officers are also not allowed to participate in any procurement proceedings.
- 3.3 A Tenderer shall not have a conflict of interest. Any tenderer found to have a conflict of interest shall be disqualified. A tenderer may be considered to have a conflict of interest for the purpose of this tendering process, if the tenderer:
 - a) Directly or indirectly controls, is controlled by or is under common control with another tenderer; or
 - b) Receives or has received any direct or indirect subsidy from another tenderer; or
 - c) Has the same legal representative as another tenderer; or
 - d) Has a relationship with another tenderer, directly or through common third parties, that puts it in a position

to influence the tender of another tenderer, or influence the decisions of the Procuring Entity regarding this tendering process; or

- e) Any of its affiliates participated as a consultant in the preparation of the design or technical specifications of the works that are the subject of the tender; or
- f) any of its affiliates has been hired (or is proposed to be hired) by the Procuring Entity as Engineer for the Contract implementation; or
- g) Would be providing goods, works, or non-consulting services resulting from or directly related to consulting services for the preparation or implementation of the contract specified in this Tender Document or
- h) Has a close business or family relationship with a professional staff of the Procuring Entity who:
 - i) are directly or indirectly involved in the preparation of the Tender document or specifications of the Contract, and/or the Tender evaluation process of such contract; or
 - ii) would be involved in the implementation or supervision of such Contract unless the conflict stemming from such relationship has been resolved in a manner acceptable to the Procuring Entity throughout the tendering process and execution of the Contract.

3.4A tenderer shall not be involved in corrupt, coercive, obstructive, collusive or fraudulent practice.

A tenderer that is proven to have been involved any of these practices shall be automatically disqualified.

3.5A Tenderer (either individually or as a JV member) shall not participate in more than one Tender, except for permitted alternative tenders. This includes participation as a subcontractor in other Tenders. Such participation shall result in the disqualification of all Tenders in which the firm is involved. A firm that is not a tenderer or a JV member may participate as a subcontractor in more than one tender. Members of a joint venture may not also make an individual tender, be a subcontractor in a separate tender or be part of another joint venture for the purposes of the same Tender.

3.6A Tenderer may have the nationality of any country, subject to the restrictions pursuant to ITT 4.8. A Tenderer shall be deemed to have the nationality of a country if the Tenderer is constituted, incorporated or registered in and operates in conformity with the provisions of the laws of that country, as evidenced by its articles of incorporation (or equivalent documents of constitution or association) and its registration documents, as the case may be. This criterion also shall apply to the determination of the nationality of proposed subcontractors or sub-consultants for any part of the Contract including related Services.

3.7 Tenderer that has been debarred from participating in public procurement shall be ineligible to tender or be awarded a contract. The list of debarred firms and individuals is available from the website of PPRA www.ppra.go.ke.

3.8 Tenderers that are state-owned enterprises or institutions may be eligible to compete and be awarded a Contract(s) only if they are accredited by PPRA to be (i) a legal public entity of the state Government and/or public administration, (ii) financially autonomous and not receiving any significant subsidies or budget support from any public entity or Government, and (iii) operating under commercial law and vested with legal rights and liabilities similar to any commercial enterprise to enable it compete with firms in the private sector on an equal basis.

3.9A Firms and individuals may be ineligible if their countries of origin (a) as a matter of law or official regulations, Kenya prohibits commercial relations with that country, or (b) by an act of compliance with a decision of the United Nations Security Council taken under Chapter VII of the Charter of the United Nations, Kenya prohibits any import of goods or contracting of works or services from that country, or any payments to any country, person, or entity in that country. A tenderer shall provide such documentary evidence of eligibility satisfactory to the Procuring Entity, as the Procuring Entity shall reasonably request.

3.10 Foreign tenderers are required to source at least forty (40%) percent of their contract inputs (in supplies, subcontracts and labor) from national suppliers and contractors. To this end, a foreign tenderer shall provide in its tender documentary evidence that this requirement is met. Foreign tenderers not meeting this criterion will be automatically disqualified. Information required to enable the Procuring Entity determine if this condition is met shall be provided in for this purpose is provided in "SECTION III - EVALUATION AND QUALIFICATION CRITERIA, Item 9".

3.11 Pursuant to the eligibility requirements of ITT 4.10, a tender is considered a foreign tenderer, if the tenderer is not registered in Kenya or if the tenderer is registered in Kenya and has less than 51 percent ~~ownership~~ ownership by

Citizens. JVs are considered as foreign tenderers if the individual member firms are not registered in Kenya or if are registered in Kenya and have less than 51 percent ownership by Kenyan citizens. The JV shall not subcontract to foreign firms more than 10 percent of the contract price, excluding provisional sums.

3.12 The National Construction Authority Act of Kenya requires that all local and foreign contractors be registered with the National Construction Authority and be issued with a Registration Certificate before they can undertake any construction works in Kenya. Registration shall not be a condition for tender, but it shall be a condition of contract award and signature. A selected tenderer shall be given opportunity to register before such award and signature of contract. Application for registration with National Construction Authority may be accessed from the website www.nca.go.ke.

3.13 The Competition Act of Kenya requires that firms wishing to tender as Joint Venture undertakings which may prevent, distort or lessen competition in provision of services are prohibited unless they are exempt in accordance with the provisions of Section 25 of the Competition Act, 2010. JVs will be required to seek for exemption from the Competition Authority. Exemption shall not be a condition for tender, but it shall be a condition of contract award and signature. A JV tenderer shall be given opportunity to seek such exemption as a condition of award and signature of contract. Application for exemption from the Competition Authority of Kenya may be accessed from the website www.cak.go.ke

3.14 A Kenyan tenderer shall provide evidence of having fulfilled his/her tax obligations by producing a valid tax clearance certificate or tax exemption certificate issued by the Kenya Revenue Authority.

4. Eligible Goods, Equipment, and Services

4.1 Goods, equipment and services to be supplied under the Contract may have their origin in any country that is not eligible under ITT 3.9. At the Procuring Entity's request, Tenderers may be required to provide evidence of the origin of Goods, equipment and services.

4.2 Any goods, works and production processes with characteristics that have been declared by the relevant national environmental protection agency or by other competent authority as harmful to human beings and to the environment shall not be eligible for procurement.

5. Tenderer's Responsibilities

5.1 The tenderer shall bear all costs associated with the preparation and submission of his/her tender, and the Procuring Entity will in no case be responsible or liable for those costs.

5.2 The tenderer, at the tenderer's own responsibility and risk, is encouraged to visit and examine the Site of the Works and its surroundings, and obtain all information that may be necessary for preparing the tender and entering into a contract for construction of the Works. The costs of visiting the Site shall be at the tenderer's own expense.

5.3 The Tenderer and any of its personnel or agents will be granted permission by the Procuring Entity to enter upon its premises and lands for the purpose of such visit. The Tenderer shall indemnify the Procuring Entity against all liability arising from death or personal injury, loss of or damage to property, and any other losses and expenses incurred as a result of the inspection.

5.4 The tenderer shall provide in the Form of Tender and Qualification Information, a preliminary description of the proposed work method and schedule, including charts, as necessary or required.

B. Contents of Tender Documents

6. Sections of Tender Document

6.1 The tender document consists of Parts 1, 2, and 3, which includes all the sections specified below, and which should be read in conjunction with any Addenda issued in accordance with ITT 8.

PART 1 Tendering Procedures

- i) Section I - Instructions to Tenderers (ITT)
- ii) Section II - Tender Data Sheet (TDS)
- iii) Section III - Evaluation and Qualification Criteria
- iv) Section IV - Tendering Forms

PART 2 Works Requirements

- i) Section V - Drawings
- ii) Section VI - Specifications
- iii) Section VII - Bills of Quantities

PART 3 Conditions of Contract and Contract Forms

- i) Section VIII - General Conditions of Contract (GCC)
- ii) Section IX - Special Conditions of Contract (SC)
- iii) Section X - Contract Forms

6.2 The Invitation to Tender Document (ITT) issued by the Procuring Entity is not part of the Contract documents.

6.3 Unless obtained directly from the Procuring Entity, the Procuring Entity is not responsible for the completeness of the Tender document, responses to requests for clarification, the minutes of the pre-Tender meeting (if any), or Addenda to the Tender document in accordance with ITT 8. In case of any contradiction, documents obtained directly from the Procuring Entity shall prevail.

The Tenderer is expected to examine all instructions, forms, terms, and specifications in the Tender Document and to furnish with its Tender all information and documentation as is required by the Tender document.

7. Site Visit

7.1 The Tenderer, at the Tenderer's own responsibility and risk, is encouraged to visit and examine and inspect the Site of the Required Services and its surroundings and obtain all information that may be necessary for preparing the Tender and entering into a contract for the Services. The costs of visiting the Site shall be at the Tenderer's own expense.

8. Pre-Tender Meeting

8.1 The Procuring Entity shall specify in the **TDS** if a pre-tender meeting will be held, when and where. The Procuring Entity shall also specify in the **TDS** if a pre-arranged pretender site visit will be held and when. The Tenderer's designated representative is invited to attend a pre-arranged pretender visit of the site of the works. The purpose of the meeting will be to clarify issues and to answer questions on any matter that may be raised at that stage.

8.2 The Tenderer is requested to submit any questions in writing, to reach the Procuring Entity not later than the period specified in the **TDS** before the meeting.

8.3 Minutes of the pre-Tender meeting and the pre-arranged pretender site visit of the site of the works, if applicable, including the text of the questions asked by Tenderers and the responses given, together with any responses prepared after the meeting, will be transmitted promptly to all Tenderers who have acquired the Tender Documents in accordance with ITT 6.3. Minutes shall not identify the source of the questions asked.

8.4 The Procuring Entity shall also promptly publish anonymized (*nonames*) Minutes of the pre-Tender meeting and the pre-arranged pretender visit of the site of the works at the web page identified in the **TDS**. Any modification to the Tender Documents that may become necessary as a result of the pre-tender meeting and the pre-arranged pretender site visit, shall be made by the Procuring Entity exclusively through the issue of an Addendum pursuant to ITT 8 and not through the minutes of the pre-Tender meeting. Nonattendance at the pre-Tender meeting will not be a cause for disqualification of a Tenderer.

9. Clarification and amendments of Tender Documents

9.1 A Tenderer requiring any clarification of the Tender Document shall contact the Procuring Entity in writing at the Procuring Entity's address specified in the **TDS** or raise its enquiries during the pre-Tender meeting and the pre-

arranged pretender visit of the site of the works if provided for in accordance with ITT 8.4. The Procuring Entity will respond in writing to any request for clarification, provided that such request is received no later than the period specified in the **TDS** prior to the deadline for submission of tenders. The Procuring Entity shall forward copies of its response to all tenderers who have acquired the Tender Documents in accordance with ITT 6.3, including a description of the inquiry but without identifying its source. If specified in the **TDS**, the Procuring Entity shall also promptly publish its response at the web page identified in the **TDS**. Should the clarification result in changes to the essential elements of the Tender Documents, the Procuring Entity shall amend the Tender Documents appropriately following the procedure under ITT 8.4.

10. Amendment of Tendering Document

- 10.1 At any time prior to the deadline for submission of Tenders, the Procuring Entity may amend the Tendering document by issuing addenda.
- 10.2 Any addendum issued shall be part of the tendering document and shall be communicated in writing to all who have obtained the tendering document from the Procuring Entity in accordance with ITT 6.3. The Procuring Entity shall also promptly publish the addendum on the Procuring Entity's web page in accordance with ITT 8.4.
- 10.3 To give prospective Tenderers reasonable time in which to take an addendum into account in preparing their Tenders, the Procuring Entity shall extend, as necessary, the deadline for submission of Tenders, in accordance with ITT 25.2 below.

C. Preparation of Tenders

11. Cost of Tendering

- 11.1 The Tenderer shall bear all costs associated with the preparation and submission of its Tender, and the Procuring Entity shall not be responsible or liable for those costs, regardless of the conduct or outcome of the tendering process.

12. Language of Tender

- 12.1 The Tender, as well as all correspondence and documents relating to the tender exchanged by the tenderer and the Procuring Entity, shall be written in the English Language. Supporting documents and printed literature that are part of the Tender may be in another language provided they are accompanied by an accurate and notarized translation of the relevant passages into the English Language, in which case, for purposes of interpretation of the Tender, such translation shall govern.

13. Documents Comprising the Tender

- 13.1 The Tender shall comprise the following:
- a) Form of Tender prepared in accordance with ITT 14;
 - b) Schedules including priced Bill of Quantities, completed in accordance with ITT 14 and ITT 16;
 - c) Tender Security or Tender-Securing Declaration, in accordance with ITT 21.1;
 - d) Alternative Tender, if permissible, in accordance with ITT 15;
 - e) Authorization: written confirmation authorizing the signatory of the Tender to commit the Tenderer, in accordance with ITT 22.3;
 - f) Qualifications: documentary evidence in accordance with ITT 19 establishing the Tenderer's qualifications to perform the Contract if its Tender is accepted;
 - g) Conformity: a technical proposal in accordance with ITT 18;
 - h) Any other document required in the **TDS**.
- 13.2 In addition to the requirements under ITT 11.1, Tenders submitted by a JV shall include a copy of the Joint Venture Agreement entered into by all members. Alternatively, a letter of intent to execute a Joint Venture Agreement in the event of a successful Tender shall be signed by all members and submitted with the Tender,

together with a copy of the proposed Agreement. The Tenderer shall chronologically serialize pages of all tender documents submitted.

13.3 The Tenderer shall furnish in the Form of Tender information on commissions and gratuities, if any, paid or to be paid to agents or any other party relating to this Tender.

14. Form of Tender and Schedules

14.1 The Form of Tender and Schedules, including the Bill of Quantities, shall be prepared using the relevant forms furnished in Section IV, Tendering Forms. The forms must be completed without any alterations to the text, and no substitutes shall be accepted except as provided under ITT 20.3. All blank spaces shall be filled in with the information requested.

15. Alternative Tenders

15.1 Unless otherwise specified in the TDS, alternative Tenders shall not be considered.

15.2 When alternative times for completion are explicitly invited, a statement to that effect will be included in the TDS, and the method of evaluating different alternative times for completion will be described in Section III, Evaluation and Qualification Criteria.

15.3 Except as provided under ITT 13.4 below, Tenderers wishing to offer technical alternatives to the requirements of the Tender Documents must first price the Procuring Entity's design as described in the Tender Documents and shall further provide all information necessary for a complete evaluation of the alternative by the Procuring Entity, including drawings, design calculations, technical specifications, breakdown of prices, and proposed construction methodology and other relevant details. Only the technical alternatives, if any, of the Tenderer with the Winning Tender conforming to the basic technical requirements shall be considered by the Procuring Entity. When specified in the TDS, Tenderers are permitted to submit alternative technical solutions for specified parts of the Works, and such parts will be identified in the TDS, as will the method for their evaluating, and described in Section VII, Works' Requirements.

16. Tender Prices and Discounts

16.1 The prices and discounts (including any price reduction) quoted by the Tenderer in the Form of Tender and in the Bill of Quantities shall conform to the requirements specified below.

16.2 The Tenderer shall fill in rates and prices for all items of the Works described in the Bill of Quantities. Items against which no rate or price is entered by the Tenderer shall be deemed covered by the rates for other items in the Bill of Quantities and will not be paid for separately by the Procuring Entity. An item not listed in the priced Bill of Quantities shall be assumed to be not included in the Tender, and provided that the Tender is determined substantially responsive notwithstanding this omission, the average price of the item quoted by substantially responsive Tenderers will be added to the Tender price and the equivalent total cost of the Tender so determined will be used for price comparison.

16.3 The price to be quoted in the Form of Tender, in accordance with ITT 14.1, shall be the total price of the Tender, including any discounts offered.

16.4 The Tenderer shall quote any discounts and the methodology for their application in the Form of Tender, in accordance with ITT 14.1.

16.5 It will be specified in the TDS if the rates and prices quoted by the Tenderer are or are not subject to adjustment during the performance of the Contract in accordance with the provisions of the Conditions of Contract, except in cases where the contract is subject to fluctuations and adjustments, not fixed price. In such a case, the Tenderer shall furnish the indices and weightings for the price adjustment formulae in the Schedule of Adjustment Data and the Procuring Entity may require the Tenderer to justify its proposed indices and weightings.

16.6 Where tenders are being invited for individual lots (contracts) or for any combination of lots (packages), tenderers wishing to offer discounts for the award of more than one Contract shall specify in their Tender the price reductions applicable to each package, or alternatively, to individual Contracts within the package. Discounts shall be submitted in accordance with ITT 16.4, provided the Tenders for all lots (contracts) are opened at the same time.

16.7 All duties, taxes, and other levies payable by the Contractor under the Contract, or for any other cause, as of the date 30 days prior to the deadline for submission of Tenders, shall be included in the rates and prices and the total Tender Price submitted by the Tenderer.

17. Currencies of Tender and Payment

17.1 Tenderers shall quote entirely in Kenya Shillings. The unit rates and the prices shall be quoted by the Tenderer in the Bill of Quantities, entirely in Kenya shillings. A Tenderer expecting to incur expenditures in other currencies for inputs to the Works supplied from outside Kenya shall devise own ways of getting foreign currency to meet those expenditures.

18. Documents Comprising the Technical Proposal

18.1 The Tenderer shall furnish a technical proposal including a statement of work methods, equipment, personnel, schedule and any other information as stipulated in Section IV, Tender Forms, in sufficient detail to demonstrate the adequacy of the Tenderer's proposal to meet the work's requirements and the completion time.

19. Documents Establishing the Eligibility and Qualifications of the Tenderer

19.1 Tenderers shall complete the Form of Tender, included in Section IV, Tender Forms, to establish Tenderer's eligibility in accordance with ITT 4.

19.2 In accordance with Section III, Evaluation and Qualification Criteria, to establish its qualifications to perform the Contract the Tenderer shall provide the information requested in the corresponding information sheets included in Section IV, Tender Forms.

19.3 A margin of preference will not be allowed. Preference and reservations will be allowed, individually or in joint ventures. Applying for eligibility for Preference and reservations shall supply all information required to satisfy the criteria for eligibility specified in accordance with ITT 33.1.

19.4 Tenderers shall be asked to provide, as part of the data for qualification, such information, including details of ownership, as shall be required to determine whether, according to the classification established by the Procuring Entity, a contractor or group of contractors qualifies for a margin of preference. Further the information will enable the Procuring Entity identify any actual or potential conflict of interest in relation to the procurement and/or contract management processes, or a possibility of collusion between tenderers, and thereby help to prevent any corrupt influence in relation to the procurement process or contract management.

19.5 The purpose of the information described in ITT 19.4 above overrides any claims to confidentiality which a tenderer may have. There can be no circumstances in which it would be justified for a tenderer to keep information relating to its ownership and control confidential where it is tendering to undertake public sector work and receive public sector funds. Thus, confidentiality will not be accepted by the Procuring Entity as a justification for a Tenderer's failure to disclose, or failure to provide required information on its ownership and control.

19.6 The Tenderer shall provide further documentary proof, information or authorizations that the Procuring Entity may request in relation to ownership and control which information on any changes to the information which was provided by the tenderer under ITT 6.3. The obligations to require this information shall continue for the duration of the procurement process and contract performance and after completion of the contract, if any change to the information previously provided may reveal a conflict of interest in relation to the award or management of the contract.

19.7 All information provided by the tenderer pursuant to these requirements must be complete, current and accurate as at the date of provision to the Procuring Entity. In submitting the information required pursuant to these requirements, the Tenderer shall warrant that the information submitted is complete, current and accurate as at the date of submission to the Procuring Entity.

19.8 If a tenderer fails to submit the information required by these requirements, its tender will be rejected. Similarly, if the Procuring Entity is unable, after taking reasonable steps, to verify to a reasonable degree the information submitted by a tenderer pursuant to these requirements, then the tender will be rejected.

19.9 If information submitted by a tenderer pursuant to these requirements, or obtained by the Procuring Entity (whether through its own enquiries, through notification by the public or otherwise), shows any conflict of

interest which could materially and improperly benefit the tenderer in relation to the procurement or contract management process, then:

- i) if the procurement process is still ongoing, the tenderer will be disqualified from the procurement process,
- ii) if the contract has been awarded to that tenderer, the contract award will be set aside,
- iii) the tenderer will be referred to the relevant law enforcement authorities for investigation of whether the tenderer or any other persons have committed any criminal offence.

19.10 If a tenderer submits information pursuant to these requirements that is incomplete, inaccurate or out-of-date, or attempts to obstruct the verification process, then the consequences ITT 6.7 will ensue unless the tenderer can show to the reasonable satisfaction of the Procuring Entity that any such act was not material, or was due to genuine error which was not attributable to the intentional act, negligence or recklessness of the tenderer.

20. Period of Validity of Tenders

20.1 Tenders shall remain valid for the Tender Validity period specified in the **TDS**. The Tender Validity period starts from the date fixed for the Tender submission deadline (as prescribed by the Procuring Entity in accordance with ITT 24). A Tender valid for a shorter period shall be rejected by the Procuring Entity as non-responsive.

20.2 In exceptional circumstances, prior to the expiration of the Tender validity period, the Procuring Entity may request Tenderers to extend the period of validity of their Tenders. The request and the responses shall be made in writing. If a Tender Security is requested in accordance with ITT 21.1, it shall also be extended for thirty (30) days beyond the deadline of the extended validity period. A Tenderer may refuse the request without forfeiting its Tender security. A Tenderer granting the request shall not be required or permitted to modify its Tender, except as provided in ITT 20.3.

20.3 If the award is delayed by a period exceeding the number of days to be specified in the **TDS** days beyond the expiry of the initial tender validity period, the Contract price shall be determined as follows:

- a) in the case of **fixed price** contracts, the Contract price shall be the tender price adjusted by the factor specified in the **TDS**;
- b) in the case of **adjustable price** contracts, no adjustment shall be made; or in any case, tender evaluation shall be based on the tender price without taking into consideration the applicable correction from those indicated above.

21. Tender Security

21.1 The Tenderer shall furnish as part of its Tender, either a Tender-Securing Declaration or a Tender Security as specified in the **TDS**, in original form and, in the case of a Tender Security, in the amount and currency specified in the **TDS**. A Tender-Securing Declaration shall use the form included in Section IV, Tender Forms.

21.2 If a Tender Security is specified pursuant to ITT 19.1, the Tender Security shall be a demand guarantee in any of the following forms at the Tenderer's option:

- a) an unconditional Bank Guarantee issued by reputable commercial bank); or
- b) an irrevocable letter of credit;
- c) a Banker's cheque issued by a reputable commercial bank; or
- d) another security specified in the **TDS**,

21.3 If an unconditional bank guarantee is issued by a bank located outside Kenya, the issuing bank shall have a correspondent bank located in Kenya to make it enforceable. The Tender Security shall be valid for thirty (30) days beyond the original validity period of the Tender, or beyond any period of extension if requested under ITT 20.2.

21.4 If a Tender Security or Tender-Securing Declaration is specified pursuant to ITT 19.1, any Tender not accompanied by a substantially responsive Tender Security or Tender-Securing Declaration shall be rejected by the Procuring Entity as non-responsive.

21.5 If a Tender Security is specified pursuant to ITT 21.1, the Tender Security of unsuccessful Tenderers shall be returned as promptly as possible upon the successful Tenderer's signing the Contract and furnishing the Performance Security and any other documents required in the **TDS**. The Procuring Entity shall also promptly return the tender security to the tenderers where the procurement proceedings are terminated, all tenders were

determined nonresponsive or a bidder declines to extend tender validity period.

21.6 The Tender Security of the successful Tenderer shall be returned as promptly as possible once the successful Tenderer has signed the Contract and furnished the required Performance Security, and any other documents required in the **TDS**.

21.7 The Tender Security may be forfeited or the Tender-Securing Declaration executed:

- e) if a Tenderer withdraws its Tender during the period of Tender validity specified by the Tenderer on the Form of Tender, or any extension thereto provided by the Tenderer; or
- f) if the successful Tenderer fails to:
 - i) sign the Contract in accordance with ITT 50; or
 - ii) furnish a Performance Security and if required in the **TDS**, and any other documents required in the **TDS**.

21.8 Where tender securing declaration is executed, the Procuring Entity shall recommend to the PPRA that PPRA debars the Tenderer from participating in public procurement as provided in the law.

21.9 The Tender Security or the Tender-Securing Declaration of a JV shall be in the name of the JV that submits the Tender. If the JV has not been legally constituted into a legally enforceable JV at the time of tendering, the Tender Security or the Tender-Securing Declaration shall be in the names of all future members as named in the letter of intent referred to in ITT 4.1 and ITT 11.2.

21.10 A tenderer shall not issue a tender security to guarantee itself.

22. Format and Signing of Tender

22.1 The Tenderer shall prepare one original of the documents comprising the Tender as described in ITT 13 and clearly mark it "ORIGINAL." Alternative Tenders, if permitted in accordance with ITT 15, shall be clearly marked "ALTERNATIVE." In addition, the Tenderer shall submit copies of the Tender, in the number specified in the **TDS** and clearly mark them "COPY." In the event of any discrepancy between the original and the copies, the original shall prevail.

22.2 Tenderers shall mark as "CONFIDENTIAL" all information in their Tenders which is confidential to their business. This may include proprietary information, trade secrets, or commercial or financially sensitive information.

22.3 The original and all copies of the Tender shall be typed or written in indelible ink and shall be signed by a person duly authorized to sign on behalf of the Tenderer. This authorization shall consist of a written confirmation as specified in the **TDS** and shall be attached to the Tender. The name and position held by each person signing the authorization must be typed or printed below the signature. All pages of the Tender where entries or amendments have been made shall be signed or initialed by the person signing the Tender.

22.4 In case the Tenderer is a JV, the Tender shall be signed by an authorized representative of the JV on behalf of the JV, and to be legally binding on all the members as evidenced by a power of attorney signed by their legally authorized representatives.

22.5 Any inter-lineation, erasures, or overwriting shall be valid only if they are signed or initialed by the person signing the Tender.

D. Submission and Opening of Tenders

23. Sealing and Marking of Tenders

23.1 Depending on the sizes or quantities or weight of the tender documents, a tenderer may use an envelope, package or container. The Tenderer shall deliver the Tender in a single sealed envelope, or in a single sealed package, or in a single sealed container bearing the name and Reference number of the Tender, addressed to the Procuring Entity and a warning not to open before the time and date for Tender opening date. Within the single envelope, package or container, the Tenderer shall place the following separate, sealed envelopes:

- a) in an envelope or package or container marked "ORIGINAL", all documents comprising the Tender, as described in ITT 11; and

- b) in an envelope or package or container marked “COPIES”, all required copies of the Tender; and
- c) if alternative Tenders are permitted in accordance with ITT 15, and if relevant:
 - i) in an envelope or package or container marked “ORIGINAL –ALTERNATIVE TENDER”, the alternative Tender; and
 - ii) in the envelope or package or container marked “COPIES- ALTERNATIVE TENDER”, all required copies of the alternative Tender.

The inner envelopes or packages or containers shall:

- a) bear the name and address of the Procuring Entity.
- b) bear the name and address of the Tenderer; and
- c) bear the name and Reference number of the Tender.

23.2 If an envelope or package or container is not sealed and marked as required, the *Procuring Entity* will assume no responsibility for the misplacement or premature opening of the Tender. Tenders that are misplaced or opened prematurely will not be accepted.

24. Deadline for Submission of Tenders

24.1 Tenders must be received by the Procuring Entity at the address specified in the **TDS** and no later than the date and time also specified in the **TDS**. When so specified in the **TDS**, Tenderers shall have the option of submitting their Tenders electronically. Tenderers submitting Tenders electronically shall follow the electronic Tender submission procedures specified in the **TDS**.

24.2 The Procuring Entity may, at its discretion, extend the deadline for the submission of Tenders by amending the Tender Documents in accordance with ITT 8, in which case all rights and obligations of the Procuring Entity and Tenderers previously subject to the deadline shall thereafter be subject to the deadline as extended.

25. Late Tenders

25.1 The Procuring Entity shall not consider any Tender that arrives after the deadline for submission of tenders, in accordance with ITT 24. Any Tender received by the Procuring Entity after the deadline for submission of Tenders shall be declared late, rejected, and returned unopened to the Tenderer.

26. Withdrawal, Substitution, and Modification of Tenders

26.1 A Tenderer may withdraw, substitute, or modify its Tender after it has been submitted by sending a written notice, duly signed by an authorized representative, and shall include a copy of the authorization in accordance with ITT 22.3, (except that withdrawal notices do not require copies). The corresponding substitution or modification of the Tender must accompany the respective written notice. All notices must be:

- a) prepared and submitted in accordance with ITT 22 and ITT 23 (except that withdrawal notices do not require copies), and in addition, the respective envelopes shall be clearly marked “WITHDRAWAL,” “SUBSTITUTION,” “MODIFICATION;” and
- b) received by the Procuring Entity prior to the deadline prescribed for submission of Tenders, in accordance with ITT 24.

26.2 Tenders requested to be withdrawn in accordance with ITT 26.1 shall be returned unopened to the Tenderers.

26.3 No Tender may be withdrawn, substituted, or modified in the interval between the deadline for submission of Tenders and the expiration of the period of Tender validity specified by the Tenderer on the Form of Tender or any extension thereof.

27. Tender Opening

27.1 Except in the cases specified in ITT 23 and ITT 26.2, the Procuring Entity shall publicly open and read out all Tenders received by the deadline, at the date, time and place specified in the **TDS**, in the presence of Tenderers' designated representatives who chooses to attend. Any specific electronic Tender opening procedures required if electronic Tendering is permitted in accordance with ITT 24.1, shall be as specified in the **TDS**.

27.2 First, envelopes marked “WITHDRAWAL” shall be opened and read out and the envelopes with the corresponding Tender shall not be opened, but returned to the Tenderer. No Tender withdrawal shall be permitted unless the corresponding withdrawal notice contains a valid authorization to request the withdrawal

and is read out at Tender opening.

- 27.3 Next, envelopes marked “SUBSTITUTION” shall be opened and read out and exchanged with the corresponding Tender being substituted, and the substituted Tender shall not be opened, but returned to the Tenderer. No Tender substitution shall be permitted unless the corresponding substitution notice contains a valid authorization to request the substitution and is read out at Tender opening.
- 27.4 Next, envelopes marked “MODIFICATION” shall be opened and read out with the corresponding Tender. No Tender modification shall be permitted unless the corresponding modification notice contains a valid authorization to request the modification and is read out at Tender opening.
- 27.5 Next, all remaining envelopes shall be opened one at a time, reading out: the name of the Tenderer and whether there is a modification; the total Tender Price, per lot (contract) if applicable, including any discounts and alternative Tenders; the presence or absence of a Tender Security or Tender-Securing Declaration, if required; and any other details as the Procuring Entity may consider appropriate.
- 27.6 Only Tenders, alternative Tenders and discounts that are opened and read out at Tender opening shall be considered further for evaluation. The Form of Tender and pages of the Bills of Quantities are to be initialed by the members of the tender opening committee attending the opening. The number of representatives of the Procuring Entity to sign shall be specified in the **TDS**.
- 27.7 At the Tender Opening, the Procuring Entity shall neither discuss the merits of any Tender nor reject any Tender (except for late Tenders, in accordance with ITT 25.1).
- 27.8 The Procuring Entity shall prepare minutes of the Tender Opening that shall include, as a minimum:
- a) the name of the Tenderer and whether there is a withdrawal, substitution, or modification;
 - b) the Tender Price, per lot (contract) if applicable, including any discounts;
 - c) any alternative Tenders;
 - d) the presence or absence of a Tender Security, if one was required.
 - e) number of pages of each tender document submitted.
- 27.9 The Tenderers' representatives who are present shall be requested to sign the minutes. The omission of a Tenderer's signature on the minutes shall not invalidate the contents and effect of the minutes. A copy of the tender opening register shall be distributed to all Tenderers upon request.

E. Evaluation and Comparison of Tenders

28. Confidentiality

- 28.1 Information relating to the evaluation of Tenders and recommendation of contract award shall not be disclosed to Tenderers or any other persons not officially concerned with the Tender process until information on Intention to Award the Contract is transmitted to all Tenderers in accordance with ITT 46.
- 28.2 Any effort by a Tenderer to influence the Procuring Entity in the evaluation of the Tenders or Contract award decisions may result in the rejection of its tender.
- 28.3 Notwithstanding ITT 28.2, from the time of tender opening to the time of contract award, if a tenderer wishes to contact the Procuring Entity on any **matter related to the tendering process, it shall do so in writing**.

29. Clarification of Tenders

- 29.1 To assist in the examination, evaluation, and comparison of the tenders, and qualification of the tenderers, the Procuring Entity may, at its discretion, ask any tenderer for a clarification of its tender, given a reasonable time for a response. Any clarification submitted by a tenderer that is not in response to a request by the Procuring Entity shall not be considered. The Procuring Entity's request for clarification and the response shall be in writing. No change, including any voluntary increase or decrease, in the prices or substance of the tender shall be sought, offered, or permitted, except to confirm the correction of arithmetic errors discovered by the Procuring Entity in the evaluation of the tenders, in accordance with ITT 33.
- 29.2 If a tenderer does not provide clarifications of its tender by the date and time set in the Procuring Entity's request for clarification, its Tender may be rejected.

30. Deviations, Reservations, and Omissions

30.1 During the evaluation of tenders, the following definitions apply:

- a) "Deviation" is a departure from the requirements specified in the tender document;
- b) "Reservation" is the setting of limiting conditions or withholding from complete acceptance of the requirements specified in the tender document; and
- c) "Omission" is the failure to submit part or all of the information or documentation required in the Tender document.

31. Determination of Responsiveness

31.1 The Procuring Entity's determination of a Tender's responsiveness is to be based on the contents of the tender itself, as defined in ITT 13.

31.2 A substantially responsive Tender is one that meets the requirements of the Tender document without material deviation, reservation, or omission. **A material deviation, reservation, or omission is one that, if accepted, would:**

- a) affect in any substantial way the scope, quality, or performance of the Works specified in the Contract; or
- b) limit in any substantial way, inconsistent with the tender document, the Procuring Entity's rights or the tenderer's obligations under the proposed contract; or
- c) if rectified, would unfairly affect the competitive position of other tenderers presenting substantially responsive tenders.

31.3 The Procuring Entity shall examine the technical aspects of the tender submitted in accordance with ITT 18, to confirm that all requirements of Section VII, Works' Requirements have been met without any material deviation, reservation or omission.

31.4 If a tender is not substantially responsive to the requirements of the tender document, it shall be rejected by the Procuring Entity and may not subsequently be made responsive by correction of the material deviation, reservation, or omission.

32. Non-material Non-conformities

32.1 Provided that a tender is substantially responsive, the Procuring Entity may waive any non-conformities in the tender.

32.2 Provided that a Tender is substantially responsive, the Procuring Entity may request that the tenderer submit the necessary information or documentation, within a reasonable period, to rectify nonmaterial non-conformities in the tender related to documentation requirements. Requesting information or documentation on such non-conformities shall not be related to any aspect of the price of the tender. Failure of the tenderer to comply with the request may result in the rejection of its tender.

32.3 Provided that a tender is substantially responsive, the Procuring Entity shall rectify quantifiable nonmaterial non-conformities related to the Tender Price. To this effect, the Tender Price shall be adjusted, for comparison purposes only, to reflect the price of a missing or non-conforming item or component in the manner specified in the **TDS**.

33. Arithmetical Errors

33.1 The tender sum as submitted and read out during the tender opening shall be absolute and final and shall not be the subject of correction, adjustment or amendment in any way by any person or entity.

33.2 Provided that the Tender is substantially responsive, the Procuring Entity shall handle errors on the following basis:

- a) Any error detected if considered a major deviation that affects the substance of the tender, shall lead to disqualification of the tender as non-responsive.
- b) Any errors in the submitted tender arising from a miscalculation of unit price, quantity, and subtotal and total bid price shall be considered as a major deviation that affects the substance of the tender and shall lead to disqualification of the tender as non-responsive. and
- c) if there is a discrepancy between words and figures, the amount in words shall prevail

33.3 Tenderers shall be notified of any error detected in their bid during the notification of a ward.

34. Currency provisions

34.1 Tenders will be priced in Kenya Shillings only. Tenderers quoting in currencies other than in Kenya shillings will be determined non-responsive and rejected.

35. Margin of Preference and Reservations

35.1 No margin of preference shall be allowed on contracts for small works.

35.2 Where it is intended to reserve the contract to specific groups under Small and Medium Enterprises, or enterprise of women, youth and/or persons living with disability, who are appropriately registered as such by the authority to be specified in the **TDS**, a procuring entity shall ensure that the invitation to tender specifically indicates that only businesses/firms belonging to those specified groups are the only ones eligible to tender. Otherwise if no so stated, the invitation will be open to all tenderers.

36. Nominated Subcontractors

36.1 Unless otherwise stated in the **TDS**, the Procuring Entity does not intend to execute any specific elements of the Works by subcontractors selected in advance by the Procuring Entity.

36.2 Tenderers may propose subcontracting up to the percentage of total value of contracts or the volume of works as specified in the **TDS**. Subcontractors proposed by the Tenderer shall be fully qualified for their parts of the Works.

36.3 The subcontractor's qualifications shall not be used by the Tenderer to qualify for the Works unless their specialized parts of the Works were previously designated by the Procuring Entity in the **TDS** as can be met by subcontractors referred to hereafter as 'Specialized Subcontractors', in which case, the qualifications of the Specialized Subcontractors proposed by the Tenderer may be added to the qualifications of the Tenderer.

37. Evaluation of Tenders

37.1 The Procuring Entity shall use the criteria and methodologies listed in this ITT and Section III, Evaluation and Qualification Criteria. No other evaluation criteria or methodologies shall be permitted. By applying the criteria and methodologies the Procuring Entity shall determine the Best Evaluated Tender in accordance with ITT 40.

37.2 To evaluate a Tender, the Procuring Entity shall consider the following:

- a) price adjustment due to discount offered in accordance with ITT 16;
- b) converting the amount resulting from applying (a) and (b) above, if relevant, to a single currency in accordance with ITT 39;
- c) price adjustment due to quantifiable non-material non-conformities in accordance with ITT 30.3; and
- d) any additional evaluation factors specified in the **TDS** and Section III, Evaluation and Qualification Criteria.

37.3 The estimated effect of the price adjustment provisions of the Conditions of Contract, applied over the period of execution of the Contract, shall not be considered in Tender evaluation.

37.4 In the case of multiple contracts or lots, Tenderers shall be allowed to tender for one or more lots and the methodology to determine the lowest evaluated cost of the lot (contract) combinations, including any discounts offered in the **Form of Tender**, is specified in **Section III, Evaluation and Qualification Criteria**.

38. Comparison of Tenders

38.1 The Procuring Entity shall compare the evaluated costs of all substantially responsive Tenders established in accordance with ITT 38.2 to determine the Tender that has the lowest evaluated cost.

39. Abnormally Low Tenders

39.1 An Abnormally Low Tender is one where the Tender price, in combination with other elements of the Tender, appears so low that it raises material concerns as to the capability of the Tenderer in regards to the Tenderer's ability to perform the Contract for the offered Tender Price or that genuine competition between Tenderers is compromised.

39.2 In the event of identification of a potentially Abnormally Low Tender, the Procuring Entity shall seek written clarifications from the Tenderer, including detailed price analyses of its Tender price in relation to the subject matter of the contract, scope, proposed methodology, schedule, allocation of risks and responsibilities and any other requirements of the Tender document.

39.3 After evaluation of the price analyses, in the event that the Procuring Entity determines that the Tenderer has failed to demonstrate its capability to perform the Contract for the offered Tender Price, the Procuring Entity shall reject the Tender.

40. Abnormally High Tenders

40.1 An abnormally high price is one where the tender price, in combination with other constituent elements of the Tender, appears unreasonably too high to the extent that the Procuring Entity is concerned that it (the Procuring Entity) may not be getting value for money or it may be paying too high a price for the contract compared with market prices or that genuine competition between Tenderers is compromised.

40.2 In case of an abnormally high tender price, the Procuring Entity shall make a survey of the market prices, check if the estimated cost of the contract is correct and review the Tender Documents to check if the specifications, scope of work and conditions of contract are contributory to the abnormally high tenders. The Procuring Entity may also seek written clarification from the tenderer on the reason for the high tender price. The Procuring Entity shall proceed as follows:

- i) If the tender price is abnormally high based on wrong estimated cost of the contract, the Procuring Entity may accept or not accept the tender depending on the Procuring Entity's budget considerations.
- ii) If specifications, scope of work and/or conditions of contract are contributory to the abnormally high tender prices, the Procuring Entity shall reject all tenders and may retender for the contract based on revised estimates, specifications, scope of work and conditions of contract, as the case may be.

40.3 If the Procuring Entity determines that the Tender Price is abnormally too high because genuine competition between tenderers is compromised (*often due to collusion, corruption or other manipulations*), the Procuring Entity shall reject all Tenders and shall institute or cause competent Government Agencies to institute an investigation on the cause of the compromise, before retendering.

41. Unbalanced and/or Front-Loaded Tenders

41.1 If in the Procuring Entity's opinion, the Tender that is evaluated as the lowest evaluated price is seriously unbalanced and/or front loaded, the Procuring Entity may require the Tenderer to provide written clarifications. Clarifications may include detailed price analyses to demonstrate the consistency of the tender prices with the scope of works, proposed methodology, schedule and any other requirements of the Tender document.

41.2 After the evaluation of the information and detailed price analyses presented by the Tenderer, the Procuring Entity may as appropriate:

- a) accept the Tender; or
- b) require that the total amount of the Performance Security be increased at the expense of the Tenderer to a level not exceeding a 30% of the Contract Price; or
- c) agree on a payment mode that eliminates the inherent risk of the Procuring Entity paying too much for undelivered works; or
- d) reject the Tender,

42. Qualifications of the Tenderer

42.1 The Procuring Entity shall determine to its satisfaction whether the eligible Tenderer that is selected as having submitted the lowest evaluated cost and substantially responsive Tender, meets the qualifying criteria specified in Section III, Evaluation and Qualification Criteria.

42.2 The determination shall be based upon an examination of the documentary evidence of the Tenderer's qualifications submitted by the Tenderer, pursuant to ITT 19. The determination shall not take into consideration the qualifications of other firms such as the Tenderer's subsidiaries, parent entities, affiliates, subcontractors (other than Specialized Subcontractors if permitted in the Tender document), or any other firm(s) different from the Tenderer.

42.3 An affirmative determination shall be a prerequisite for award of the Contract to the Tenderer. A negative

determination shall result in disqualification of the Tender, in which event the Procuring Entity shall proceed to the Tenderer who offers a substantially responsive Tender with the next lowest evaluated price to make a similar determination of that Tenderer's qualifications to perform satisfactorily.

42.4 An Abnormally Low Tender is one where the Tender price, in combination with other elements of the Tender, appears so low that it raises material concerns as to the capability of the Tenderer in regards to the Tenderer's ability to perform the Contract for the offered Tender Price.

42.5 In the event of identification of a potentially Abnormally Low Tender, the Procuring Entity shall seek written clarifications from the Tenderer, including detailed price analyses of its Tender price in relation to the subject matter of the contract, scope, proposed methodology, schedule, allocation of risks and responsibilities and any other requirements of the Tender document.

42.6 After evaluation of the price analyses, if the Procuring Entity determines that the Tenderer has failed to demonstrate its capability to perform the Contract for the offered Tender Price, the Procuring Entity shall reject the Tender.

43. Best Evaluated Tender

43.1 Having compared the evaluated prices of Tenders, the Procuring Entity shall determine the Best Evaluated Tender. The Best Evaluated Tender is the Tender of the Tenderer that meets the Qualification Criteria and whose Tender has been determined to be:

- a) Most responsive to the Tender document; and
- b) the lowest evaluated price.

44. Procuring Entity's Right to Accept Any Tender, and to Reject Any or All Tenders.

44.1 The Procuring Entity reserves the right to accept or reject any Tender and to annul the Tender process and reject all Tenders at any time prior to Contract Award, without thereby incurring any liability to Tenderers. In case of annulment, all Tenderers shall be notified with reasons and all Tenders submitted and specifically, Tender securities, shall be promptly returned to the Tenderers.

F. Award of Contract

45. Award Criteria

45.1 The Procuring Entity shall award the Contract to the successful tenderer whose tender has been determined to be the Lowest Evaluated Tender.

46. Notice of Intention to enter into a Contract

46.1 Upon award of the contract and Prior to the expiry of the Tender Validity Period the Procuring Entity shall issue a Notification of Intention to Enter into a Contract / Notification of award to all tenderers which shall contain, at a minimum, the following information:

- a) the name and address of the Tenderer submitting the successful tender;
- b) the Contract price of the successful tender;
- c) a statement of the reason(s) the tender of the unsuccessful tenderer to whom the letter is addressed was unsuccessful, unless the price information in (c) above already reveals the reason;
- d) the expiry date of the Standstill Period; and
- e) instructions on how to request a debriefing and/or submit a complaint during the standstill period;

47. Standstill Period

47.1 The Contract shall not be signed earlier than the expiry of a Standstill Period of 14 days to allow any dissatisfied tender to launch a complaint. Where only one Tender is submitted, the Standstill Period shall not apply.

47.2 Where a Standstill Period applies, it shall commence when the Procuring Entity has transmitted to each Tenderer the Notification of Intention to Enter **into a Contract with the successful Tenderer.**

48. Debriefing by the Procuring Entity

48.1 On receipt of the Procuring Entity's Notification of Intention to Enter into a Contract referred to in ITT 46, an unsuccessful tenderer may make a written request to the Procuring Entity for a debriefing on specific issues or concerns regarding their tender. The Procuring Entity shall provide the debriefing within five days of receipt of the request.

48.2 Debriefings of unsuccessful Tenderers may be done in writing or verbally. The Tenderer shall bear its own costs of attending **such a debriefing meeting**.

49. Letter of Award

49.1 Prior to the expiry of the Tender Validity Period and upon expiry of the Standstill Period specified in ITT 42.1, upon addressing a complaint that has been filed within the Standstill Period, the Procuring Entity shall transmit the Letter of Award to the successful Tenderer. The letter of award shall request the successful tenderer to furnish the Performance Security within 21 days of the date of the letter.

50. Signing of Contract

50.1 Upon the expiry of the fourteen days of the Notification of Intention to enter into contract and upon the parties meeting their respective statutory requirements, the Procuring Entity shall send the successful Tenderer the Contract Agreement.

50.2 Within fourteen (14) days of receipt of the Contract Agreement, the successful Tenderer shall sign, date, and return it to the Procuring Entity.

50.3 The written contract shall be entered into within the period specified in the notification of award and before expiry of the tender validity period

51. Appointment of Adjudicator

51.1 The Procuring Entity proposes the person named in the **TDS** to be appointed as Adjudicator under the Contract, at the hourly fee specified in the **TDS**, plus reimbursable expenses. If the Tenderer disagrees with this proposal, the Tenderer should so state in his Tender. If, in the Letter of Acceptance, the Procuring Entity does not agree on the appointment of the Adjudicator, the Procuring Entity will request the Appointing Authority designated in the Special Conditions of Contract (SCC) pursuant to Clause 23.1 of the General Conditions of Contract (GCC), to appoint the Adjudicator.

52. Performance Security

52.1 Within twenty-one (21) days of the receipt of the Letter of Acceptance from the Procuring Entity, the successful Tenderer shall furnish the Performance Security and, any other documents required in the **TDS**, in accordance with the General Conditions of Contract, subject to ITT 40.2 (b), using the Performance Security and other Forms included in Section X, Contract Forms, or another form acceptable to the Procuring Entity. A foreign institution providing a bank guarantee shall have a correspondent financial institution located in Kenya, unless the Procuring Entity has agreed in writing that a correspondent bank is not required.

52.2 Failure of the successful Tenderer to submit the above-mentioned Performance Security and other documents required in the **TDS**, or sign the Contract shall constitute sufficient grounds for the annulment of the award and forfeiture of the Tender Security. In that event the Procuring Entity may award the Contract to the Tenderer offering the next Best Evaluated Tender.

52.3 Performance security shall not be required for contracts estimated to cost less than Kenya shillings five million shillings.

53. Publication of Procurement Contract

53.1 Within fourteen days after signing the contract, the Procuring Entity shall publish the awarded contract at its notice boards and websites; and on the Website of the Authority. At the minimum, the notice shall contain the following information:

- a) name and address of the Procuring Entity;
- b) name and reference number of the contract being awarded, a summary of its scope and the selection

- method used;
- c) the name of the successful Tenderer, the final total contract price, the contract duration.
- d) dates of signature, commencement and completion of contract;
- e) names of all Tenderers that submitted Tenders, and their Tender prices as read out at Tender opening.

54. Procurement Related Complaints and Administrative Review

54.1 The procedures for making Procurement-related Complaints are as specified in the **TDS**.

54.2 A request for administrative review shall be made in the form provided under contract forms.

Section II - Tender Data Sheet (TDS)

The following specific data shall complement, supplement, or amend the provisions in the Instructions to Tenderers (ITT). Whenever there is a conflict, the provisions herein shall prevail over those in ITT.

ITT Reference	PARTICULARS OF APPENDIX TO INSTRUCTIONS TO TENDERS
	A. General
ITT 1.1	<p>THE TENDER REFERENCE NUMBER (ITT) IS: NG-CDF/CHSMEI/DCC/001/2025-2026</p> <p>THE PROCURING ENTITY IS: NG-CDF CHESUMEI CONSTITUENCY</p> <p>THE NAME OF THE ITT: Proposed Construction of Digital Hub at Deputy County Commissioner Office-Chesumei</p>
ITT 2.1	NOT APPLICABLE
ITT 3.3	The Information made available on competing firms is as follows:
ITT 4.1	Maximum number of members in the Joint Venture (JV) shall be: NONE
B. Contents of Tender Document	
ITT 8.2	The Tenderer will submit any questions in writing, to reach the Procuring Entity not later than 25 th June 2026
ITT 8.4	pretender site visit. Allowed

ITT 9.1	For Clarification of Tender purposes, for obtaining further information and for purchasing tender documents, the Procuring Entity's address is: Attention: NG-CDF CHESUMEI CONSTITUENCY Postal Address: P.O Box 40-30300 KAPSABET
----------------	---

ITT Reference	PARTICULARS OF APPENDIX TO INSTRUCTIONS TO TENDERS
C. Preparation of Tenders	
ITP 13.1 (h)	The Tenderer shall submit the following additional documents in its Tender: <i>AS PER THE EVALUATION CRITERIA AND THE ADVERT</i>
ITT 15.1	Alternative Tenders SHALL NOT be considered.
ITT 15.2	Alternative times for completion SHALL NOT BE permitted.
ITT 15.4	Alternative technical solutions shall be permitted for the following parts of the Works: SHALL NOT BE ALLOWED
ITT 16.5	The prices quoted by the Tenderer shall be <i>FIXED</i>
ITT 20.1	The Tender validity period shall be 90 DAYS _
ITT 20.3 (a)) The delayed to exceeding <u> 30 </u> number of days. AS PER CONTRACT DAYS) The Tender price shall be adjusted by the following percentages of the tender price:
ITT 21.1	A Tender Security of <i>N/A Bid Price shall</i> be required. If a Tender Security shall be required, the amount and currency of the Tender Security shall be <i>As Above</i> FROM FINANCIAL INSTITUTION RECOGNISED BY Central Bank of Kenya, Bank Guarantee, Credit Note OR INSUARANCE COMPANIES APPROVED BY PPRA
ITT 21.2 (d)	The other Tender Security shall be <u> NOT APPLICABLE </u>
ITT 21.5	On the Performance Security, other documents required shall be <u> ASPER </u> <u> SPECIAL CONDITONS OF CONTRACT </u>
ITT 22.1	In addition to the original of the Tender, the number of copies is: ONLY ORIGINAL
ITT 22.3	The written confirmation of authorization to sign on behalf of the Tenderer shall consist of: <i>WRITEN POWER OF ATTORNEY/ FROM COMMISSIONER OF OATHS</i>
D. Submission and Opening of Tenders	

ITT 24.1	(A) For <u>Tender submission purposes</u> only, the Procuring Entity's address is: NG-CDF CHESUMEI CONSTITUENCY P.O BOX 40-30300 KAPSABET

ITT Reference	PARTICULARS OF APPENDIX TO INSTRUCTIONS TO TENDERS
ITT 25.1	The deadline for Tender submission is: --- 29 TH June, 2026, 2:00 Pm Tenderers shall not have the option of submitting their Tenders electronically.
ITT 26.1	The Tender opening shall take place at: NG-CDF CHESUMEI CONSTITUENCY BOARDROOM P.O BOX 40-30300 KAPSABET
ITT 26.2	The electronic Tender opening procedures shall NOT be APPLICABLE
ITT 26.6	The Form of Tender and priced Schedule of requirements shall be initialed by TENDER OPENING COMMITTEE

E. Evaluation and Comparison of Tenders

ITT 33.2	The currency shall be Kenya Shillings and the source of exchange rate shall be Central bank of Kenya as on as on five (5) calendar days prior to the deadline for submission of bids
ITT 34.2	Margin of preference shall be not allowed.

F. Award of Contract

ITT 44.1	The negotiations will be held at NG-CDF CHESUMEI CONSTITUENCY
ITT 49.1	<p>The procedures for making a Procurement-related Complaint are available from the PPRA Website www.ppra.go.ke or email complaints@ppra.go.ke.</p> <p>If a Tenderer wishes to make a Procurement-related Complaint, the Tenderer should submit its complaint following these procedures, in writing (by the quickest means available, that is either by hand delivery or email to:</p> <p>For the attention: FUND ACCOUNT MANAGER</p> <p>Procuring Entity: NG-CDF CHESUMEI CONSTITUENCY</p> <p>Email address:</p> <p>In summary, a Procurement-related Complaint may challenge any of the following:</p> <p>(i) the terms of the Tender Documents; and the Procuring Entity's decision to award the contract.</p>

SECTION III - EVALUATION AND QUALIFICATION CRITERIA

1. General Provisions

Wherever a Tenderer is required to state a monetary amount, Tenderers should indicate the Kenya Shilling equivalent using the rate of exchange determined as follows:

- a) For construction turnover or financial data required for each year - Exchange rate prevailing on the last day of the respective calendar year (in which the amounts for that year is to be converted) was originally established.
- b) Value of single contract - Exchange rate prevailing on the date of the contract signature.
- c) Exchange rates shall be taken from the publicly available source identified in the ITT 14.3. Any error in determining the exchange rates in the Tender may be corrected by the Procuring Entity.

This section contains the criteria that the Employer shall use to evaluate tender and qualify tenderers. No other factors, methods or criteria shall be used other than specified in this tender document. The Tenderer shall provide all the information requested in the forms included in Section IV, Tendering Forms. The Procuring Entity should use **the Standard Tender Evaluation Document for Goods and Works** for evaluating Tenders.

Evaluation and contract award Criteria

The Procuring Entity shall use the criteria and methodologies listed in this Section to evaluate tenders and arrive at the Lowest Evaluated Tender. The tender that (i) meets the qualification criteria, (ii) has been determined to be substantially responsive to the Tender Documents, and (iii) is determined to have the Lowest Evaluated Tender price shall be selected for award of contract.

2. Preliminary examination for Determination of Responsiveness

The Procuring Entity will start by examining all tenders to ensure they meet in all respects the eligibility criteria and other requirements in the ITT, and that the tender is complete in all aspects in meeting the requirements of “Part 2 – Procuring Entity's Works Requirements”, including checking for tenders with unacceptable errors, abnormally low tenders, abnormally high tenders and tenders that are front loaded. The Standard Tender Evaluation Report Document for Goods and Works for evaluating Tenders provides very clear guide on how to deal with review of these requirements. Tenders that do not pass the Preliminary Examination will be considered irresponsive and will not be considered further.

[The Procuring Entity will provide the preliminary evaluation criteria. To facilitate, a template may be attached or clearly described all information and list of documentation to be submitted by Tenderers to enable preliminary evaluation of the Tender]

STAGE 1: PRELIMINARY EVALUATION

ITEM	MANDATORY REQUIREMENT (MR) – MAIN CONTRACTOR
MR1	Certificate of Incorporation / Registration from the Registrar of Companies / Businesses;
MR2	(Valid copy of Certificate of CR12 or CR13) for list of directors, beneficial owners, name of proprietor or names of partners issued not more than 12 months before the closure of the tender
MR3	Current Category of Registration with National Construction Authority (NCA) in the relevant trade; (NCA 8 and above for Building Works)
MR 4	Certificate Contractor's Annual Practicing License from NCA for the current year
MR5	Must submit a copy of valid tax compliance
MR6	VAT/PIN registration certificate (Copy).
MR7	<ul style="list-style-type: none"> • Dully filled forms (Original): • Form of tender, • Confidential business questionnaire, • Certificate of independent tender determination, • Self-declaration forms SD1 and SD2 and • Declaration and commitment to the code of ethics
MR8	Valid copy of Trading / Business Permit
MR9	The Bid has been submitted in the format required by the procuring entity - the tender document to be returned in the order and pages provided in the tender and paginated in sequence including attachments. Use of spiral binding and box files will lead to automatic disqualification.

STAGE 2: TECHNICAL EVALUATION CRITERIA

The award of points for evidence provided or the standard forms considered in this section shall Be as shown below;

PARAMETER	MAXIMUM POINTS
(i) Key personnel	18
(ii) Contract Completed in the last Five (5) years -----	20
(iii) Schedules of contractor's equipment -----	20
(iv) Audited Financial Report for the last 3 years -----	12
(v) Evidence of Financial Resources -----	15
(vi) Litigation History -----	5
(vii) Work program -----	10
TOTAL	100

Item	Description
T1	Key Personnel (Attach evidence)
	<p>1. Director of the firm</p> <p>Holder of degree in relevant Engineering field-----6</p> <p>Holder of diploma in relevant Engineering field----- 3</p> <p>Holder of certificate in relevant Engineering field----- 3</p> <p>Holder of Grade I - III test certificate in relevant Engineering field----- 2</p> <p>No relevant certificate ----- 1</p> <p>2. At least 1No. degree/diploma holder of key personnel in relevant field</p> <ul style="list-style-type: none"> • With over 5 years relevant experience----- 4 • With over 3 years relevant experience-----3 • With under 1 year's relevant experience----- 2 <p>3. At least 1No. Grade III certificate holder of key personnel in relevant field</p> <ul style="list-style-type: none"> • With over 5 years relevant experience----- 4 • With over 3 years relevant experience-----3 • With under 1 year's relevant experience-----2 <p>4. At least 1 No artisan (trade test certificate in relevant field)</p> <ul style="list-style-type: none"> • Artisan with over 5 years relevant experience----- 4 • Artisan with under 3 years relevant experience----- 3 • Non skilled worker with over 5 years relevant experience----- 2
T2	EXPERIENCE
	To Score, the bidder Must attach copies of Completion Certificate confirming successful project completion for each reference.
	<p>Contract completed in the last TEN (10) years (Max of 5No. Projects)- <u>Provide Evidence</u></p> <ul style="list-style-type: none"> • Project of similar nature, complexity or magnitude----- 20 • Project of similar nature but of lower value than the one in consideration - 15 • No completed project of similar nature----- 0
T3	TRANSPORT AND EQUIPMENTS
	<p>Schedule of contractor's equipment and transport (proof or evidence of ownership/Lease)</p> <p>a) Relevant Transport</p> <p>Means of transport (Vehicle)</p> <ul style="list-style-type: none"> • At least 1 pickup ----- 5 marks • At least 1 lorry ----- 5 marks • No means of transport----- 0

Item	Description
	b) Relevant Equipment (Concrete mixers, Concrete vibrators, Wheel barrows, tile cutters, horse pipes) <ul style="list-style-type: none"> • Has relevant equipment for work being tendered----- 10 • No relevant equipment for work being tendered-----0
T4	FINANCES
	1. Signed and stamped Audited accounts for the last three financial years (2025, 2024, 2023) by certified auditors with ICPAK numbers valid for the 3 years under review/ provide the current valid auditors certificates verifiable on ICPAK portal. <ul style="list-style-type: none"> • Average Annual Turn-over equal to or greater than the cost of the project----- 12 • Average Annual Turn-over above 50% but below 100% of the cost of the project ----- 6 • Average Annual Turn-over below 50% of the cost of the project - 4 2. Evidence of Financial Resources (lines of credit/ Bank statement) <ul style="list-style-type: none"> • Has financial resources to finance the projected monthly cash flow*----- 15 • Has financial resources equal to the projected monthly cash flow*---- 10 • Has financial resources less the projected monthly cash flow* - 5 • Has not indicated sources of financial resources----- 0 Monthly Cash Flow = Tender Sum/Contract Period
T5	LITIGATION HISTORY
	No consistent history of court/arbitral award decisions against the Tenderer5
T6	WORK PROGRAMME
	Work program in (Gantt chart) and work methodology clearly describing activities with clear timelines <ul style="list-style-type: none"> a. Has both work program and work methodology----- 10 b. Has either work program or work methodology----- 5 c. No work program and work methodology provided -0
	TOTAL= 100

Detailed Scoring Plan

Tenderers who score 75% and above proceed to financial evaluation

STAGE 3: FINANCIAL EVALUATION

A) Determination of the Arithmetic Errors

Arithmetic Errors will be corrected by the Procuring Entity as follows:

- i) In the event of a discrepancy between the amount as stated in the form of Tender and the corrected tender figure in the Main summary of the Bills of Quantities, the amount as stated in the Form of tender shall prevail. Pursuant to Section 82 of the Public Procurement and Asset Disposal Act 2015, the tender sum as submitted and read out during the tender opening shall be absolute and final and shall not be the subject of correction, adjustment or amendment in any way by any person or entity;
- ii) Error correction factor shall be computed by expressing the difference between the amount and the corrected tender sum as a percentage of the corrected contract works
- iii) The Error correction factor shall be applied to all contract works (as a rebate or addition as the case may be) for the purposes of valuations for Interim Certificates and valuations of variations.

B) Comparison of rates for the bidder

Items that are under-priced or overpriced may indicate potential for non-delivery and front loading respectively. The



committee shall promptly write to the tenderer asking for detailed breakdown of costs for any of the quoted items, relationship between those prices, proposed construction/installation methods and schedules.

The evaluation committee shall evaluate the responses and make an appropriate recommendation to the procuring entity's tender committee giving necessary evidence. Such recommendations may include but not limited to:

- a) Recommend no adverse action to the tenderer after a convincing response;
- b) Employer requiring that the amount of the performance bond be raised at the expense of the successful tenderer to a level sufficient to protect the employer against potential financial losses;
- c) Recommend non-award based on the response provided and the available demonstrable evidence that the scope, quality, completion timing, administration of works to be undertaken by the tenderer, would adversely be affected or the rights of the employer or the tenderers obligations would be limited in a substantial way.

C) Consistency of the Rates

The evaluation committee will compare the consistency of rates for similar items and note all inconsistencies of the rates for similar items

STAGE 4 - DUE DELIGENCE & RECOMMENDATION FOR AWARD

Particulars of post – qualification if applicable at Kamobo Secondary School in Emgwen Constituency inspect the premises and under due diligence to seek further clarification/confirmation, if necessary, to confirm authenticity /compliance of any condition of the tender /qualifications of the tenderer in line with Section 83 of the Public Procurement and Asset Disposal Act ,2015

Award Criteria:

The firm achieving the lowest evaluated price will be awarded the contract in line with Section 86 of the Public Procurement and Disposal Act,2015

3. **Tender Evaluation (ITT 35) Price evaluation:** in addition to the criteria listed in ITT 35.2 (a) – (c) the following criteria shall apply:
- i) **Alternative Completion Times**, if permitted under ITT 13.2, will be evaluated as follows:
.....
 - ii) **Alternative Technical Solutions** for specified parts of the Works, if permitted under ITT 13.4, will be evaluated as follows:

iii) **Other Criteria; if permitted under ITT 35.2(d):**
.....

4. Multiple Contracts

Multiple contracts will be permitted in accordance with ITT 35.4. Tenderers are evaluated on basis of Lots and the lowest evaluated tenderer identified for each Lot. The Procuring Entity will select one Option of the two Options listed below for award of Contracts.

OPTION 1

- i) If a tenderer wins only one Lot, the tenderer will be awarded a contract for that Lot, provided the tenderer meets the Eligibility and Qualification Criteria for that Lot.
- ii) If a tenderer wins more than one Lot, the tenderer will be awarded contracts for all won Lots, provided the tenderer meets the aggregate Eligibility and Qualification Criteria for all the Lots. The tenderer will be awarded the combination of Lots for which the tenderer qualifies and the others will be considered for award to second lowest tenderers.

OPTION 2

The Procuring Entity will consider all possible combinations of won Lots [contract(s)] and determine the combinations with the lowest evaluated price. Tenders will then be awarded to the Tenderer or Tenderers in the combinations provided the tenderer meets the aggregate Eligibility and Qualification Criteria for all the won Lots.

5. Alternative Tenders (ITT 13.1)

An alternative if permitted under ITT 13.1, will be evaluated as follows:

The Procuring Entity shall consider Tenders offered for alternatives as specified in Part 2- Works Requirements. Only the technical alternatives, if any, of the Tenderer with the Best Evaluated Tender conforming to the basic technical requirements shall be considered by the Procuring Entity.

6. Margin of Preference is not applicable

7. Post qualification and Contract award (ITT 39), more specifically,

- a) In case the tender was subject to post-qualification, the contract shall be awarded to the lowest evaluated tenderer, subject to confirmation of pre-qualification data, if so required.
- b) In case the tender was not subject to post-qualification, the tender that has been determined to be the lowest evaluated tenderer shall be considered for contract award, subject to meeting each of the following conditions.
 - i) The Tenderer shall demonstrate that it has access to, or has available, liquid assets, unencumbered real assets, lines of credit, and other financial means (independent of any contractual advance payment) sufficient to meet the construction cash flow of Kenya Shillings _____.
 - ii) Minimum average annual construction turnover of Kenya Shillings _____ [insert amount], equivalent calculated as total certified payments received for contracts in progress and/or completed within the last _____ [insert of year] years.
 - iii) At least _____ (insert number) of contract(s) of a similar nature executed within Kenya, or the East African Community or abroad, that have been satisfactorily and substantially completed as a prime contractor, or joint venture member or sub-contractor each of minimum value Kenya shillings _____ equivalent.
 - iv) Contractor's Representative and Key Personnel, which are specified as _____
 - v) Contractors key equipment listed on the table "Contractor's Equipment" below and more specifically listed as [specify requirements for each lot applicable] _____
 - vi) Other conditions depending on their seriousness.
- a) **History of non-performing contracts:**
Tenderer and each member of JV in case the Tenderer is a JV, shall demonstrate that Non-performance of a contract did not occur because of the default of the Tenderer, or the member of a JV in the last _____ (specify years). The required information shall be furnished in the appropriate form.

b) **Pending Litigation**

Financial position and prospective long-term profitability of the Single Tenderer, and in the case the Tenderer is a JV, of each member of the JV, shall remain sound according to criteria established with respect to Financial Capability under Paragraph (i) above if all pending litigation will be resolved against the Tenderer. Tenderer shall provide information on pending litigations in the appropriate form.

c) **Litigation History**

There shall be no consistent history of court/arbitral award decisions against the Tenderer, in the last _____ (*specify years*). All parties to the contract shall furnish the information in the appropriate form about any litigation or arbitration resulting from contracts completed or ongoing under its execution over the years specified. A consistent history of awards against the Tenderer or any member of a JV may result in rejection of the tender.

8. QUALIFICATION FORMSUMMARY

1	2	3	4	5
Item No.	Qualification Subject	Qualification Requirement	Document To be Completed by Tenderer	For Procuring Entity's Use (Qualification met or Not Met)
1	Nationality	Nationality in accordance with ITT 3.6	Forms ELI – 1.1 and 1.2, with attachments	
2	Tax Obligations for Kenyan Tenderers	Has produced a current tax clearance certificate or tax exemption certificate issued by the the Kenya Revenue Authority in accordance with ITT 3.14.	Form of Tender	
3	Conflict of Interest	No conflicts of interest in accordance with ITT 3.3	Form of Tender	
4	PPRA Eligibility	Not having been declared ineligible by the PPRA as described in ITT 3.8	Form of Tender	
5	State- owned Enterprise	Meets conditions of ITT 3.7	Forms ELI – 1.1 and 1.2, with attachments	
6	Goods, equipment and services to be supplied under the contract	To have their origin in any country that is not determined ineligible under ITT 4.1	Forms ELI – 1.1 and 1.2, with attachments	
7	History of Non-Performing Contracts	Non-performance of a contract did not occur as a result of contractor default since 1 st January [.....].	Form CON-2	
8	Suspension Based on Execution of Tender/Proposal Securing Declaration by the Procuring Entity	Not under suspension based on-execution of a Tender/Proposal Securing Declaration pursuant to ITT 19.9	Form of Tender	
9	Pending Litigation	Tender's financial position and prospective long-term profitability still sound according to criteria established in 3.1 and assuming that all pending litigation will NOT be resolved against the Tenderer.	Form CON – 2	
10	Litigation History	No consistent history of court/arbitral award decisions against the Tenderer since 1 st January [<i>insert year</i>]	Form CON – 2	
11	Financial Capabilities	(i) The Tenderer shall demonstrate that it has access to, or has available, liquid assets, unencumbered real assets, lines of credit, and other financial means (independent of any contractual advance payment) sufficient to meet the construction cash flow requirements estimated as Kenya Shillings [<i>insert amount</i>] equivalent for the subject contract(s) net of the Tenderer's other commitments.	Form FIN – 3.1, with attachments	

1	2	3	4	5
Item No.	Qualification Subject	Qualification Requirement	Document To be Completed by Tenderer	For Procuring Entity's Use (Qualification met or Not Met)
		<p>(ii) The Tenderers shall also demonstrate, to the satisfaction of the Procuring Entity, that it has adequate sources of finance to meet the cash flow requirements on works currently in progress and for future contract commitments.</p> <p>(iii) The audited balance sheets or, if not required by the laws of the Tenderer's country, other financial statements acceptable to the Procuring Entity, for the last <i>[insert number of years]</i> years shall be submitted and must demonstrate the current soundness of the Tenderer's financial position and indicate its prospective long-term profitability.</p>		
12	Average Annual Construction Turnover	Minimum average annual construction turnover of Kenya Shillings <i>[insert amount]</i> , equivalent calculated as total certified payments received for contracts in progress and/or completed within the last <i>[insert of year]</i> years, divided by <i>[insert number of years]</i> years	Form FIN – 3.2	
13	General Construction Experience	Experience under construction contracts in the role of prime contractor, JV member, sub-contractor, or management contractor for at least the last <i>[insert number of years]</i> years, starting 1 st January <i>[insert year]</i> .	Form EXP – 4.1	
	Specific Construction & Contract Management Experience	<p>A minimum number of <i>[state the number]</i> similar contracts specified below that have been satisfactorily and substantially completed as a prime contractor, joint venture member, management contractor or sub-contractor between 1st January <i>[insert year]</i> and tender submission deadline i.e. (number) contracts, each of minimum value Kenya shillings..... equivalent.</p> <p><i>[In case the Works are to be tender as individual contracts under multiple contract procedure, the minimum number of contracts required for purposes of evaluating qualification shall be selected from the options mentioned in ITT 35.4]</i></p> <p>The similarity of the contracts shall be based on the following: <i>[Based on Section VII, Scope of Works, specify</i></p>	Form EXP 4.2(a)	

1 Item No.	2 Qualification Subject	3 Qualification Requirement	4 <i>Document To be Completed by Tenderer</i>	5 <i>For Procuring Entity's Use (Qualification met or Not Met)</i>
		<i>the minimum key requirements in terms of physical size, complexity, construction method, technology and/or other characteristics including part of the requirements that may be met by specialized subcontractors, if permitted in accordance with ITT 34.3]</i>		

QUALIFICATION FORMS

1. FORMEQU: EQUIPMENT

The Tenderer shall provide adequate information to demonstrate clearly that it has the capability to meet the requirements for the key equipment listed in Section III, Evaluation and Qualification Criteria. A separate Form shall be prepared for each item of equipment listed, or for alternative equipment proposed by the Tenderer.

Item of equipment		
Equipment information	Name of manufacturer	Model and power rating
	Capacity	Year of manufacture
Current status	Current location	
	Details of current commitments	
Source	Indicate source of the equipment <input type="checkbox"/> Owned <input type="checkbox"/> Rented <input type="checkbox"/> Leased <input type="checkbox"/> Specially manufactured	

Omit the following information for equipment owned by the Tenderer.

Owner	Name of owner	
	Address of owner	
	Telephone	Contact name and title
	Fax	Telex
Agreements	Details of rental / lease / manufacture agreements specific to the project	

2. FORM PER -1

Contractor's Representative and Key Personnel Schedule

Tenderers should provide the names and details of the suitably qualified Contractor's Representative and Key Personnel to perform the Contract. The data on their experience should be supplied using the Form PER-2 below for each candidate.

Contractor' Representative and Key Personnel

1.	Title of position: Contractor's Representative	
	Name of candidate:	
	Duration of appointment:	<i>[insert the whole period (start and end dates) for which this position will be engaged]</i>
	Time commitment: for this position:	<i>[insert the number of days/week/months/ that has been scheduled for this position]</i>
	Expected time schedule for this position:	<i>[insert the expected time schedule for this position (e.g. attach high level Gantt chart)]</i>
2.	Title of position: []	
	Name of candidate:	
	Duration of appointment:	<i>[insert the whole period (start and end dates) for which this position will be engaged]</i>
	Time commitment: for this position:	<i>[insert the number of days/week/months/ that has been scheduled for this position]</i>
	Expected time schedule for this position:	<i>[insert the expected time schedule for this position (e.g. attach high level Gantt chart)]</i>
3.	Title of position: []	
	Name of candidate:	
	Duration of appointment:	<i>[insert the whole period (start and end dates) for which this position will be engaged]</i>
	Time commitment: for this position:	<i>[insert the number of days/week/months/ that has been scheduled for this position]</i>
	Expected time schedule for this position:	<i>[insert the expected time schedule for this position (e.g. attach high level Gantt chart)]</i>
4.	Title of position: []	
	Name of candidate:	
	Duration of appointment:	<i>[insert the whole period (start and end dates) for which this position will be engaged]</i>
	Time commitment: for this position:	<i>[insert the number of days/week/months/ that has been scheduled for this position]</i>
	Expected time schedule for this position:	<i>[insert the expected time schedule for this position (e.g. attach high level Gantt chart)]</i>
5.	Title of position: [insert title]	
	Name of candidate	
	Duration of appointment:	<i>[insert the whole period (start and end dates) for which this position will be engaged]</i>
	Time commitment: for this position:	<i>[insert the number of days/week/months/ that has been scheduled for this position]</i>
	Expected time schedule for this position:	<i>[insert the expected time schedule for this position (e.g. attach high level Gantt chart)]</i>

3. **FORM PER-2:**

Resume and Declaration - Contractor's Representative and Key Personnel.

Summarize professional experience in reverse chronological order. Indicate particular technical and managerial experience relevant to the project.

Name of Tenderer

Position [#I]: <i>[title of position from Form PER-1]</i>	
Personnel information	Name: Date of birth:
	Address: E-mail:
	Professional qualifications:
	Academic qualifications:
	Language proficiency: <i>[language and levels of speaking, reading and writing skills]</i>
Details	Address of Procuring Entity:
	Telephone: Contact (manager / personnel officer):
	Fax:
	Job title: Years with present Procuring Entity:

Summarize professional experience in reverse chronological order. Indicate particular technical and managerial experience relevant to the project.

Project	Role	Duration of involvement	Relevant experience
<i>[main project details]</i>	<i>[role and responsibilities on the project]</i>	<i>[time in role]</i>	<i>[describe the experience relevant to this position]</i>

Declaration

I, the undersigned *[insert either "Contractor's Representative" or "Key Personnel" as applicable]*, certify that to the best of my knowledge and belief, the information contained in this Form PER-2 correctly describes myself, my qualifications and my experience.

I confirm that I am available as certified in the following table and throughout the expected time schedule for this position as provided in the Tender:

Commitment	Details
Commitment to duration of contract:	<i>[insert period (start and end dates) for which this Contractor's Representative or Key Personnel is available to work on this contract]</i>
Time commitment:	<i>[insert period (start and end dates) for which this Contractor's Representative or Key Personnel is available to work on this contract]</i>

I understand that any misrepresentation or omission in this Form may:

- a) be taken into consideration during Tender evaluation;
- b) result in my disqualification from participating in the Tender;
- c) result in my dismissal from the contract.

Name of Contractor's Representative or Key Personnel: *[insert name]*

Signature: _____

Date:(day month year): _____ Countersignature

of authorized representative of the Tenderer:

Signature: _____ Date:(daymonth

year): _____

4. TENDERER'S QUALIFICATION WITHOUT PRE-QUALIFICATION

To establish its qualifications to perform the contract in accordance with Section III, Evaluation and Qualification Criteria the Tenderer shall provide the information requested in the corresponding Information Sheets included hereunder.

4.1 FORM ELI -1.1

Tenderer Information Form

Date: _____

ITT No. and title: _____

Tenderer's name
In case of Joint Venture (JV), name of each member:
Tenderer's actual or intended country of registration: <i>[indicate country of Constitution]</i>
Tenderer's actual or intended year of incorporation:
Tenderer's legal address [in country of registration]:
Tenderer's authorized representative information Name: _____ Address: _____ Telephone/Fax numbers: _____ E-mail address: _____
1. Attached are copies of original documents of <input type="checkbox"/> Articles of Incorporation (or equivalent documents of constitution or association), and/or documents of registration of the legal entity named above, in accordance with ITT 3.6 <input type="checkbox"/> In case of JV, letter of intent to form JV or JV agreement, in accordance with ITT 3.5 <input type="checkbox"/> In case of state-owned enterprise or institution, in accordance with ITT 3.8, documents establishing: <ul style="list-style-type: none">• Legal and financial autonomy• Operation under commercial law• Establishing that the Tenderer is not under the supervision of the Procuring Entity
2. Included are the organizational chart and a list of Board of Directors.

4.2 **FORMELI-1.2**

Tenderer's JV Information Form (to be completed for each member of Tenderer's JV)

Date: _____

ITT No. and title: _____

Tenderer's JV name:
JV member's name:
JV member's country of registration:
JV member's year of constitution:
JV member's legal address in country of constitution:
JV member's authorized representative information Name: _____ Address: _____ Telephone/Fax numbers: _____ E-mail address: _____
1. Attached are copies of original documents of <input type="checkbox"/> Articles of Incorporation (or equivalent documents of constitution or association), and/or registration documents of the legal entity named above, in accordance with ITT 3.6. <input type="checkbox"/> In case of a state-owned enterprise or institution, documents establishing legal and financial autonomy, operation in accordance with commercial law, and that they are not under the supervision of the Procuring Entity, in accordance with ITT 3.8. 2. Included are the organizational chart and a list of Board of Directors.

4.3 **FORM CON – 2**

Historical Contract Non-Performance, Pending Litigation and Litigation History

Tenderer's Name: _____

Date: _____

JV Member's Name _____

ITT No. and title: _____

Non-Performed Contracts in accordance with Section III, Evaluation and Qualification Criteria			
<input type="checkbox"/> Contract non-performance did not occur since 1 st January <i>[insert year]</i> specified in Section III, Evaluation and Qualification Criteria, Sub-Factor 2.1.			
<input type="checkbox"/> Contract(s) not performed since 1 st January <i>[insert year]</i> specified in Section III, Evaluation and Qualification Criteria, requirement 2.1			
Year	Non-performed portion of contract	Contract Identification	Total Contract Amount (current value, currency, exchange rate and Kenya Shilling equivalent)
<i>[insert year]</i>	<i>[insert amount and percentage]</i>	Contract Identification: <i>[indicate complete contract name/ number, and any other identification]</i> Name of Procuring Entity: <i>[insert full name]</i> Address of Procuring Entity: <i>[insert street/city/country]</i> Reason(s) for nonperformance: <i>[indicate main reason(s)]</i>	<i>[insert amount]</i>
Pending Litigation, in accordance with Section III, Evaluation and Qualification Criteria			
<input type="checkbox"/> No pending litigation in accordance with Section III, Evaluation and Qualification Criteria, Sub-Factor 2.3.			
<input type="checkbox"/> Pending litigation in accordance with Section III, Evaluation and Qualification Criteria, Sub-Factor 2.3 as indicated below.			

Year of dispute	Amount in dispute (currency)	Contract Identification	Total Contract Amount (currency), Kenya Shilling Equivalent (exchange rate)
		Contract Identification: _____ Name of Procuring Entity: _____ Address of Procuring Entity: _____ Matter in dispute: _____ Party who initiated the dispute: _____ Status of dispute: _____	
		Contract Identification: _____ Name of Procuring Entity: _____ Address of Procuring Entity: _____ Matter in dispute: _____ Party who initiated the dispute: _____ Status of dispute: _____	
Litigation History in accordance with Section III, Evaluation and Qualification Criteria			
<input type="checkbox"/> No Litigation History in accordance with Section III, Evaluation and Qualification Criteria, Sub-Factor 2.4.			
<input type="checkbox"/> Litigation History in accordance with Section III, Evaluation and Qualification Criteria, Sub-Factor 2.4 as indicated below.			

Year of award	Outcome as percentage of Net Worth	Contract Identification	Total Contract Amount (currency), Kenya Shilling Equivalent (exchange rate)
[insert year]	[insert percentage]	Contract Identification: [indicate complete contract name, number, and any other identification] Name of Procuring Entity: [insert full name] Address of Procuring Entity: [insert street/city/country] Matter in dispute: [indicate main issues in dispute] Party who initiated the dispute: [indicate "Procuring Entity" or "Contractor"] Reason(s) for Litigation and award decision [indicate main reason(s)]	[insert amount]

4.4 **FORM FIN – 3.1:**

Financial Situation and Performance

Tenderer's Name: _____
 Date: _____
 JV Member's Name _____
 ITT No. and title: _____

4.4.1. Financial Data

Type of Financial information in _____ (currency)	Historic information for previous _____ years, (amount in currency, currency, exchange rate*, USD equivalent)				
	Year 1	Year 2	Year 3	Year 4	Year 5
Statement of Financial Position (Information from Balance Sheet)					
Total Assets (TA)					
Total Liabilities (TL)					
Total Equity/Net Worth (NW)					
Current Assets (CA)					
Current Liabilities (CL)					
Working Capital (WC)					
Information from Income Statement					
Total Revenue (TR)					

Type of Financial information in _____ (currency)	Historic information for previous _____ years,				
	(amount in currency, currency, exchange rate*, USD equivalent)				
	Year 1	Year 2	Year 3	Year 4	Year 5
Profits Before Taxes (PBT)					
Cash Flow Information					
Cash Flow from Operating Activities					

*Refer to ITT 15 for the exchange rate

4.4.2 Sources of Finance

Specify sources of finance to meet the cash flow requirements on works currently in progress and for future contract commitments.

No.	Source of finance	Amount (Kenya Shilling equivalent)
1		
2		
3		

4.4.3 Financial documents

The Tenderer and its parties shall provide copies of financial statements for _____ years pursuant Section III, Evaluation and Qualifications Criteria, Sub-factor 3.1. The financial statements shall:

- (a) reflect the financial situation of the Tenderer or in case of JV member, and not an affiliated entity (such as parent company or group member).
- (b) be independently audited or certified in accordance with local legislation.
- (c) be complete, including all notes to the financial statements.
- (d) correspond to accounting periods already completed and audited.

Attached are copies of financial statements¹ for the _____ years required above; and complying with the requirements

¹ If the most recent set of financial statements is for a period earlier than 12 months from the date of Tender, the reason for this should be justified.

4.5 FORM FIN – 3.2:

Average Annual Construction Turnover

Tenderer's Name: _____

Date: _____

JV Member's Name _____

ITT No. and title: _____

Annual turnover data (construction only)			
Year	Amount Currency	Exchange rate	Kenya Shilling equivalent
<i>[indicate year]</i>	<i>[insert amount and indicate currency]</i>		
Average Annual Construction Turnover *			

* See Section III, Evaluation and Qualification Criteria, Sub-Factor 3.2.

4.6 FORM FIN – 3.3:

Financial Resources

Specify proposed sources of financing, such as liquid assets, unencumbered real assets, lines of credit, and other financial means, net of current commitments, available to meet the total construction cash flow demands of the subject contract or contracts as specified in Section III, Evaluation and Qualification Criteria

Financial Resources		
No.	Source of financing	Amount (Kenya Shilling equivalent)
1		
2		
3		

4.7 FORM EN – 3.4:

Current Contract Commitments / Works in Progress

Tenderers and each member to a JV should provide information on their current commitments on all contracts that have been awarded, or for which a letter of intent or acceptance has been received, or for contracts approaching completion, but for which an unqualified, full completion certificate has yet to be issued.

Current Contract Commitments					
	Name of Contract	Procuring Entity's Contact Address, Tel,	Value of Outstanding Work [Current Kenya Shilling /month Equivalent]	Estimated Completion Date	Average Monthly Invoicing Over Last Six Months [Kenya Shilling /month]
1					
2					
3					
4					
5					

4.8 FORM EXP - 4.1

General Construction Experience

Tenderer's Name: _____

Date: _____

JV Member's Name _____

ITT No. and title: _____

Page _____ of _____ pages

Starting Year	Ending Year	Contract Identification	Role of Tenderer
		Contractname: _____ Brief Description of the Works performed by the Tenderer: _____ Amount of contract: _____ Name of Procuring Entity: _____ Address: _____	
		Contract name: _____ Brief Description of the Works performed by the Tenderer: _____ Amount of contract: _____ Name of Procuring Entity: _____ Address: _____	
		Contractname: _____ Brief Description of the Works performed by the Tenderer: _____ Amount of contract: _____ Name of Procuring Entity: _____ Address: _____	

4.9 FORM EXP - 4.2(a)**Specific Construction and Contract Management Experience**

Tenderer's Name: _____

Date: _____

JV Member's Name _____

ITT No. and title: _____

Similar Contract No.	Information			
Contract Identification				
Award date				
Completion date				
Role in Contract	Prime Contractor <input type="checkbox"/>	Member in JV <input type="checkbox"/>	Management Contractor <input type="checkbox"/>	Sub-contractor <input type="checkbox"/>
Total Contract Amount	Kenya Shilling			
If member in a JV or sub-contractor, specify participation in total Contract amount				
Procuring Entity's Name:				
Address:				
Telephone/fax number				
E-mail:				

4.10 FORM EXP - 4.2 (a) (cont.)**Specific Construction and Contract Management Experience (cont.)**

Similar Contract No.	Information
Description of the similarity in accordance with Sub-Factor 4.2(a) of Section III:	
1. Amount	
2. Physical size of required works items	
3. Complexity	
4. Methods/Technology	
5. Construction rate for key activities	
6. Other Characteristics	

4.11 FORM EXP - 4.2(b)

Construction Experience in Key Activities

Tenderer's Name: _____

Date: _____

Tenderer's JV Member Name: _____

Sub-contractor's Name² (as per ITT 34): _____

ITT No. and title: _____

All Sub-contractors for key activities must complete the information in this form as per ITT 34 and Section III, Evaluation and Qualification Criteria, Sub-Factor 4.2.

1. Key Activity No One: _

Information				
Contract Identification				
Award date				
Completion date				
Role in Contract	Prime Contractor <input type="checkbox"/>	Member in JV <input type="checkbox"/>	Management Contractor <input type="checkbox"/>	Sub-contractor <input type="checkbox"/>
Total Contract Amount			Kenya Shilling	
Quantity (Volume, number or rate of production, as applicable) performed under the contract per year or part of the year	Total quantity in the contract (i)	Percentage participation (ii)		Actual Quantity Performed (i) x (ii)
Year 1				
Year 2				
Year 3				
Year 4				
Procuring Entity's Name:				
Address: Telephone/fax number E-mail:				

² If applicable

	Information
Description of the key activities in accordance with Sub-Factor 4.2(b) of Section III:	

2. Activity No. Two

3.

OTHER FORMS

5. FORM OF TENDER

(Amended and issued pursuant to PPRA CIRCULAR No. 02/2022)

INSTRUCTIONS TO TENDERERS

- i) All italicized text is to help the Tenderer in preparing this form.*
- ii) The Tenderer must prepare this Form of Tender on stationery with its letterhead clearly showing the Tenderer's complete name and business address. Tenderers are reminded that this is a mandatory requirement.*
- iii) Tenderer must complete and sign CERTIFICATE OF INDEPENDENT TENDER DETERMINATION and the SELF DECLARATION FORMS OF THE TENDERER as listed under (s) below.*

Date of this Tender submission:.....[insert date (as day, month and year) of Tender submission] **Tender**

Name **and** **Identification:**.....[insert *identification*] **Alternative**

No.:.....[insert identification No if this is a Tender for an alternative]

To.....[Insert complete name of Procuring Entity]

Dear Sirs,

1. In accordance with the Conditions of Contract, Specifications, Drawings and Bills of Quantities for the execution of the above named Works, we, the undersigned offer to construct and complete the Works and remedy any defects therein for the sum of Kenya Shillings [[Amount in figures]_____ Kenya Shillings [amount in words]_____.

The above amount includes foreign currency amount (s) of [state figure or a percentage and currency] [figures]_____ [words]_____.

The percentage or amount quoted above does not include provisional sums, and only allows not more than two foreign currencies.

2. We undertake, if our tender is accepted, to commence the Works as soon as is reasonably possible after the receipt of the Project Manager's notice to commence, and to complete the whole of the Works comprised in the Contract within the time stated in the Special Conditions of Contract.
3. We agree to adhere by this tender until _____ [Insert date], and it shall remain binding upon us and may be accepted at any time before that date.
4. Unless and until a formal Agreement is prepared and executed this tender together with your written acceptance thereof, shall constitute a binding Contract between us. We further understand that you are not bound to accept the lowest or any tender you may receive.
5. We, the undersigned, further declare that:
 - i) No reservations: We have examined and have no reservations to the tender document, including Addenda issued in accordance with ITT 28;
 - ii) Eligibility: We meet the eligibility requirements and have no conflict of interest in accordance with ITT 3 and 4;
 - iii) Tender-Securing Declaration: We have not been suspended nor declared ineligible by the Procuring Entity based on execution of a Tender-Securing or Proposal-Securing Declaration in the Procuring Entity's Country in accordance with ITT 19.8;
 - iv) Conformity: We offer to execute in conformity with the tendering documents and in accordance with the implementation and completion specified in the construction schedule, the following Works: [insert a brief description of the Works];

- v) Tender Price: The total price of our Tender, excluding any discounts offered in item 1 above is: *[Insert one of the options below as appropriate]*
- vi) Option 1, in case of one lot: Total price is: *[insert the total price of the Tender in words and figures, indicating the various amounts and the respective currencies]*; Or
- Option 2, in case of multiple lots:
- a) Total price of each lot *[insert the total price of each lot in words and figures, indicating the various amounts and the respective currencies]*; and
- b) Total price of all lots (sum of all lots) *[insert the total price of all lots in words and figures, indicating the various amounts and the respective currencies]*;
- vii) Discounts: The discounts offered and the methodology for their application are:
- viii) The discounts offered are: *[Specify in detail each discount offered.]*
- ix) The exact method of calculations to determine the net price after application of discounts is shown below: *[Specify in detail the method that shall be used to apply the discounts]*;
- x) Tender Validity Period: Our Tender shall be valid for the period specified in TDS 18.1 (as amended, if applicable) from the date fixed for the Tender submission deadline specified in TDS 22.1 (as amended, if applicable), and it shall remain binding upon us and may be accepted at any time before the expiration of that period;
- xi) Performance Security: If our Tender is accepted, we commit to obtain a Performance Security in accordance with the Tendering document;
- xii) One Tender Per Tender: We are not submitting any other Tender(s) as an individual Tender, and we are not participating in any other Tender(s) as a Joint Venture member or as a subcontractor, and meet the requirements of ITT 3.4, other than alternative Tenders submitted in accordance with ITT 13.3;
- xiii) Suspension and Debarment: We, along with any of our subcontractors, suppliers, Project Manager, manufacturers, or service providers for any part of the contract, are not subject to, and not controlled by any entity or individual that is subject to, a temporary suspension or a debarment imposed by the Public Procurement Regulatory Authority or any other entity of the Government of Kenya, or any international organization.
- xiv) State-owned enterprise or institution: *[select the appropriate option and delete the other]* *[We are not a state-owned enterprise or institution]* / *[We are a state-owned enterprise or institution but meet the requirements of ITT 3.8]*;
- xv) Commissions, gratuities, fees: We have paid, or will pay the following commissions, gratuities, or fees with respect to the tender process or execution of the Contract: *[insert complete name of each Recipient, its full address, the reason for which each commission or gratuity was paid and the amount and currency of each such commission or gratuity]*.

Name of Recipient	Address	Reason	Amount

(If none has been paid or is to be paid, indicate "none.")

- xvi) Binding Contract: We understand that this Tender, together with your written acceptance thereof included in your Letter of Acceptance, shall constitute a binding contract between us, until a formal contract is prepared and executed;
- xvii) Not Bound to Accept: We understand that you are not bound to accept the lowest evaluated cost Tender, the Most Advantageous Tender or any other Tender that you may receive;
- xviii) Fraud and Corruption: We hereby certify that we have taken steps to ensure that no person acting for us or on our behalf engages in any type of Fraud and Corruption;

- xix) **Collusive practices:** We hereby certify and confirm that the tender is genuine, non-collusive and made with the intention of accepting the contract if awarded. To this effect we have signed the “Certificate of Independent Tender Determination” attached below.
- xx) We undertake to adhere by the Code of Ethics for Persons Participating in Public Procurement and Asset Disposal, copy available from _____ (*specify website*) during the procurement process and the execution of any resulting contract.
- xxi) **Beneficial Ownership Information:** We commit to provide to the procuring entity the Beneficial Ownership Information in conformity with the Beneficial Ownership Disclosure Form upon receipt of notification of intention to enter into a contract in the event we are the successful tenderer in this subject procurement proceeding.
- xxii) We, the Tenderer, have duly completed, signed and stamped the following Forms as part of our Tender:
- Tenderer's Eligibility; Confidential Business Questionnaire – to establish we are not in any conflict to interest.
 - Certificate of Independent Tender Determination – to declare that we completed the tender without colluding with other tenderers.
 - Self-Declaration of the Tenderer – to declare that we will, if awarded a contract, not engage in any form of fraud and corruption.
 - Declaration and commitment to the Code of Ethics for Persons Participating in Public Procurement and Asset Disposal

Further, we confirm that we have read and understood the full content and scope of fraud and corruption as informed in “**Appendix 1- Fraud and Corruption**” attached to the Form of Tender.

Name of the Tenderer: **[insert complete name of person signing the Tender]*

Name of the person duly authorized to sign the Tender on behalf of the Tenderer: ***[insert complete name of person duly authorized to sign the Tender]*

Title of the person signing the Tender:*[insert complete title of the person signing the Tender]*

Signature of the person named above: *[insert signature of person whose name and capacity are shown above]* **Date signed** *[insert date of signing]* day of *[insert month]*, *[insert year]*

Date signed _____ day of _____, _____

Notes

** In the case of the Tender submitted by joint venture specify the name of the Joint Venture as Tenderer*

*** Person signing the Tender shall have the power of attorney given by the Tenderer to be attached with the Tender.*

A. TENDERER'S ELIGIBILITY- CONFIDENTIAL BUSINESS QUESTIONNAIRE

Instruction to Tenderer

Tender is instructed to complete the particulars required in this Form, *one form for each entity if Tender is a JV*. Tenderer is further reminded that it is an offence to give false information on this Form.

(a) Tenderer's details

	ITEM	DESCRIPTION
1	Name of the Procuring Entity	
2	Reference Number of the Tender	
3	Date and Time of Tender Opening	
4	Name of the Tenderer	
5	Full Address and Contact Details of the Tenderer.	1. Country 2. City 3. Location 4. Building 5. Floor 6. Postal Address 7. Name and email of contact person.
6	Current Trade License Registration Number and Expiring date	
7	Name, country and full address (<i>postal and physical addresses, email, and telephone number</i>) of Registering Body/Agency	
8	Description of Nature of Business	
9	Maximum value of business which the Tenderer handles.	
10	State if Tenders Company is listed in stock exchange, give name and full address (<i>postal and physical addresses, email, and telephone number</i>) of state which stock exchange	

General and Specific Details

b) **Sole Proprietor**, provide the following details.

Name in full _____ Age _____ Nationality _____
 _____ Country of Origin _____ Citizenship _____

c) **Partnership**, provide the following details.

	Names of Partners	Nationality	Citizenship	% Shares owned
1				
2				
3				

d) **Registered Company**, provide the following details.

i) Private or public Company _____

ii) State the nominal and issued capital of the Company _____

Nominal Kenya Shillings (Equivalent)..... Issued

Kenya Shillings (Equivalent).....

iii) Give details of Directors as follows.

	Names of Director	Nationality	Citizenship	% Shares owned
1				
2				
3				

(e) **DISCLOSURE OF INTEREST- Interest of the Firm in the Procuring Entity.**

i) Are there any person/persons in..... (*Name of Procuring Entity*) who has/have an interest or relationship in this firm? Yes/No.....

If yes, provide details as follows.

	Names of Person	Designation in the Procuring Entity	Interest or Relationship with Tenderer
1			
2			
3			

ii) **Conflict of interest disclosure**

	Type of Conflict	Disclosure YES OR NO	If YES provide details of the relationship with Tenderer
1	Tenderer is directly or indirectly controls, is controlled by or is under common control with another tenderer.		
2	Tenderer receives or has received any direct or indirect subsidy from another tenderer.		
3	Tenderer has the same legal representative as another tenderer		
4	Tender has a relationship with another tenderer, directly or through common third parties, that puts it in a position to influence the tender of another tenderer, or influence the decisions of the Procuring Entity regarding this tendering process.		

	Type of Conflict	Disclosure YES OR NO	If YES provide details of the relationship with Tenderer
5	Any of the Tenderer's affiliates participated as a consultant in the preparation of the design or technical specifications of the works that are the subject of the tender.		
6	Tenderer would be providing goods, works, non-consulting services or consulting services during implementation of the contract specified in this Tender Document.		
7	Tenderer has a close business or family relationship with a professional staff of the Procuring Entity who are directly or indirectly involved in the preparation of the Tender document or specifications of the Contract, and/or the Tender evaluation process of such contract.		
8	Tenderer has a close business or family relationship with a professional staff of the Procuring Entity who would be involved in the implementation or supervision of the such Contract.		
9	Has the conflict stemming from such relationship stated in item 7 and 8 above been resolved in a manner acceptable to the Procuring Entity throughout the tendering process and execution of the Contract.		

f) Certification

On behalf of the Tenderer, I certify that the information given above is complete, current and accurate as at the date of submission.

Full Name _____ Title or

Designation _____

(Signature)

(Date)

B. CERTIFICATE OF INDEPENDENT TENDER DETERMINATION

I, the undersigned, in submitting the accompanying Letter of Tender to the _____ [Name of Procuring Entity] for: _____ [Name and number of tender] in response to the request for tenders made by: _____ [Name of Tenderer] do hereby make the following statements that I certify to be true and complete in every respect:

I certify, on behalf of _____ [Name of Tenderer] that:

1. I have read and understand the contents of this Certificate;
2. I understand that the Tender will be disqualified if this Certificate is found not to be true and complete in every respect;
3. I am the authorized representative of the Tenderer with authority to sign this Certificate, and to submit the Tender on behalf of the Tenderer;
4. For the purposes of this Certificate and the Tender, I understand that the word "competitor" shall include any individual or organization, other than the Tenderer, whether or not affiliated with the Tenderer, who:
 - a) has been requested to submit a Tender in response to this request for tenders;
 - b) could potentially submit a tender in response to this request for tenders, based on their qualifications, abilities or experience;
5. The Tenderer discloses that [check one of the following, as applicable]:
 - a) The Tenderer has arrived at the Tender independently from, and without consultation, communication, agreement or arrangement with, any competitor;
 - b) the Tenderer has entered into consultations, communications, agreements or arrangements with one or more competitors regarding this request for tenders, and the Tenderer discloses, in the attached document(s), complete details thereof, including the names of the competitors and the nature of, and reasons for, such consultations, communications, agreements or arrangements;
6. In particular, without limiting the generality of paragraphs (5)(a) or (5)(b) above, there has been no consultation, communication, agreement or arrangement with any competitor regarding:
 - a) prices;
 - b) methods, factors or formulas used to calculate prices;
 - c) the intention or decision to submit, or not to submit, a tender; or
 - d) the submission of a tender which does not meet the specifications of the request for Tenders; except as specifically disclosed pursuant to paragraph (5)(b) above;
7. In addition, there has been no consultation, communication, agreement or arrangement with any competitor regarding the quality, quantity, specifications or delivery particulars of the works or services to which this request for tenders relates, except as specifically authorized by the procuring authority or as specifically disclosed pursuant to paragraph (5)(b) above;
8. the terms of the Tender have not been, and will not be, knowingly disclosed by the Tenderer, directly or indirectly, to any competitor, prior to the date and time of the official tender opening, or of the awarding of the Contract, whichever comes first, unless otherwise required by law or as specifically disclosed pursuant to paragraph (5)(b) above.

Name _____ Title _____ Date _____

[Name, title and signature of authorized agent of Tenderer and Date].

FORM SD2

SELF DECLARATION THAT THE PERSON/TENDERER WILL NOT ENGAGE IN ANY CORRUPT OR FRAUDULENT PRACTICE

I, of P. O. Box..... being a resident of in the Republic of..... do hereby make a statement as follows: -

1. THAT I am the Chief Executive/Managing Director/Principal Officer/Director of..... (*insert name of the Company*) who is a Bidder in respect of Tender No..... for (*insert tender title/description*) for..... (*insert name of the Procuring entity*) and duly authorized and competent to make this statement.
2. THAT the aforesaid Bidder, its servants and/or agents /subcontractors will not engage in any corrupt or fraudulent practice and has not been requested to pay any inducement to any member of the Board, Management, Staff and/or employees and/or agents of..... (*insert name of the Procuring entity*) which is the procuring entity.
3. THAT the aforesaid Bidder, its servants and/or agents /subcontractors have not offered any inducement to any member of the Board, Management, Staff and/or employees and/or agents of.....(name of the procuring entity)
4. THAT the aforesaid Bidder will not engage /has not engaged in any corrosive practice with other bidders participating in the subject tender
5. THAT what is deponed to herein above is true to the best of my knowledge information and belief.

.....
(Title)

.....
(Signature)

.....
(Date)

Bidder's Official Stamp

DECLARATION AND COMMITMENT TO THE CODE OF ETHICS

I (person) on behalf of (*Name of the Business/ Company/Firm*)..... declare that I have read and fully understood the contents of the Public Procurement & Asset Disposal Act, 2015, Regulations and the Code of Ethics for persons participating in Public Procurement and Asset Disposal and my responsibilities under the Code.

Ido hereby commit to abide by the provisions of the Code of Ethics for persons participating in Public Procurement and Asset Disposal.

Name of Authorized signatory..... Sign.....

Position.....

Office address..... Telephone.....

E-mail.....

Name of the Firm/Company.....

Date..... (Company Seal/ Rubber

Stamp where applicable)

Witness

Name Sign.....

Date.....

D. APPENDIX 1- FRAUD AND CORRUPTION

(Appendix 1 shall not be modified)

1. Purpose

2. The Government of Kenya's Anti-Corruption and Economic Crime laws and their sanctions policies and procedures, Public Procurement and Asset Disposal Act (*no. 33 of 2015*) and its Regulation, and any other Kenya's Acts or Regulations related to Fraud and Corruption, and similar offences, shall apply with respect to Public Procurement Processes and Contracts that are governed by the laws of Kenya.

3. Requirements

The Government of Kenya requires that all parties including Procuring Entities, Tenderers, (applicants/proposers), Consultants, Contractors and Suppliers; any Sub-contractors, Sub-consultants, Service providers or Suppliers; any Agents (whether declared or not); and any of their Personnel, involved and engaged in procurement under Kenya's Laws and Regulation, observe the highest standard of ethics during the procurement process, selection and contract execution of all contracts, and refrain from Fraud and Corruption and fully comply with Kenya's laws and Regulations as per paragraphs 1.1 above.

Kenya's public procurement and asset disposal act (*no. 33 of 2015*) under Section 66 describes rules to be followed and actions to be taken in dealing with Corrupt, Coercive, Obstructive, Collusive or Fraudulent practices, and Conflicts of Interest in procurement including consequences for offences committed. A few of the provisions noted below highlight Kenya's policy of no tolerance for such practices and behavior: -

- 1) a person to whom this Act applies shall not be involved in any corrupt, coercive, obstructive, collusive or fraudulent practice; or conflicts of interest in any procurement or asset disposal proceeding;
- 2) A person referred to under subsection (1) who contravenes the provisions of that sub-section commits an offence;
- 3) Without limiting the generality of the subsection (1) and (2), the persons shall be: -
 - a) disqualified from entering into a contract for a procurement or asset disposal proceeding; or
 - b) if a contract has already been entered into with the person, the contract shall be voidable;
- 4) The voiding of a contract by the procuring entity under subsection (7) does not limit any legal remedy the procuring entity may have;
- 5) An employee or agent of the procuring entity or a member of the Board or committee of the procuring entity who has a conflict of interest with respect to a procurement: -
 - a) shall not take part in the procurement proceedings;
 - b) shall not, after a procurement contract has been entered into, take part in any decision relating to the procurement or contract; and
- c) shall not be a subcontractor for the bidder to whom was awarded contract, or a member of the group of bidders to whom the contract was awarded, but the subcontractor appointed shall meet all the requirements of this Act.
- 6) An employee, agent or member described in subsection (1) who refrains from doing anything prohibited under that subsection, but for that subsection, would have been within his or her duties shall disclose the conflict of interest to the procuring entity;
- 7) If a person contravenes subsection (1) with respect to a conflict of interest described in subsection (5)(a) and the contract is awarded to the person or his relative or to another person in whom one of them had a direct or indirect pecuniary interest, the contract shall be terminated and all costs incurred by the public entity shall be made good by the awarding officer. Etc.

In compliance with Kenya's laws, regulations and policies mentioned above, the Procuring Entity:

- a) Defines broadly, for the purposes of the above provisions, the terms set forth below as follows:
 - i) "corrupt practice" is the offering, giving, receiving, or soliciting, directly or indirectly, of anything of value to influence improperly the actions of another party;
 - ii) "fraudulent practice" is any act or omission, including misrepresentation, that knowingly or recklessly misleads, or attempts to mislead, a party to obtain financial or other benefit or to avoid an obligation;

- iii) “collusive practice” is an arrangement between two or more parties designed to achieve an improper purpose, including to influence improperly the actions of another party;
 - iv) “coercive practice” is impairing or harming, or threatening to impair or harm, directly or indirectly, any party or the property of the party to influence improperly the actions of a party;
 - v) “obstructive practice” is:
 - deliberately destroying, falsifying, altering, or concealing of evidence material to the investigation or making false statements to investigators in order to materially impede investigation by Public Procurement Regulatory Authority (PPRA) or any other appropriate authority appointed by Government of Kenya into allegations of a corrupt, fraudulent, coercive, or collusive practice; and/or threatening, harassing, or intimidating any party to prevent it from disclosing its knowledge of matters relevant to the investigation or from pursuing the investigation; or
 - acts intended to materially impede the exercise of the PPRA's or the appointed authority's inspection and audit rights provided for under paragraph 2.3 e. below.
- b) Defines more specifically, in accordance with the above procurement Act provisions set forth for fraudulent and collusive practices as follows:
- "fraudulent practice" includes a misrepresentation of fact in order to influence a procurement or disposal process or the exercise of a contract to the detriment of the procuring entity or the tenderer or the contractor, and includes collusive practices amongst tenderers prior to or after tender submission designed to establish tender prices at artificial non-competitive levels and to deprive the procuring entity of the benefits of free and open competition.
- c) Rejects a proposal for award¹ of a contract if PPRA determines that the firm or individual recommended for award, any of its personnel, or its agents, or its sub-consultants, sub-contractors, service providers, suppliers and/ or their employees, has, directly or indirectly, engaged in corrupt, fraudulent, collusive, coercive, or obstructive practices in competing for the contract in question;
 - d) Pursuant to the Kenya's above stated Acts and Regulations, may sanction or recommend to appropriate authority (ies) for sanctioning and debarment of a firm or individual, as applicable under the Acts and Regulations;
 - e) Requires that a clause be included in Tender documents and Request for Proposal documents requiring (i) Tenderers (applicants/proposers), Consultants, Contractors, and Suppliers, and their Sub-contractors, Sub-consultants, Service providers, Suppliers, Agents personnel, permit the PPRA or any other appropriate authority appointed by Government of Kenya to inspect² all accounts, records and other documents relating to the procurement process, selection and/or contract execution, and to have them audited by auditors appointed by the PPRA or any other appropriate authority appointed by Government of Kenya; and
 - f) Pursuant to Section 62 of the above Act, requires Applicants/Tenderers to submit along with their Applications/Tenders/Proposals a “Self-Declaration Form” as included in the procurement document declaring that they and all parties involved in the procurement process and contract execution have not engaged/will not engage in any corrupt or fraudulent practices.

¹For the avoidance of doubt, a party's ineligibility to be awarded a contract shall include, without limitation, (i) applying for pre-qualification, expressing interest in a consultancy, and tendering, either directly or as a nominated sub-contractor, nominated consultant, nominated manufacturer or supplier, or nominated service provider, in respect of such contract, and (ii) entering into an addendum or amendment introducing a material modification to any existing contract.

² Inspections in this context usually are investigative (i.e., forensic) in nature. They involve fact-finding activities undertaken by the Investigating Authority or persons appointed by the Procuring Entity to address specific matters related to investigations/audits, such as evaluating the veracity of an allegation of possible Fraud and Corruption, through the appropriate mechanisms. Such activity includes but is not limited to: accessing and examining a firm's or individual's financial records and information, and making copies thereof as relevant; accessing and examining any other documents, data and information (whether in hard copy or electronic format) deemed relevant for the investigation/audit, and making copies thereof as relevant; interviewing staff and other relevant individuals; performing physical inspections and site visits; and obtaining third party verification of information.

FORM OF TENDER SECURITY-[Option 1–Demand Bank Guarantee]

Beneficiary: _____

Request for Tenders No:

Date: _____

TENDER GUARANTEE No.: _____

Guarantor: _____

1. We have been informed that _____ (here inafter called "the Applicant") has submitted or will submit to the Beneficiary its Tender (here inafter called" the Tender") for the execution of _____ under Request for Tenders No. _____ ("the ITT").
2. Furthermore, we understand that, according to the Beneficiary's conditions, Tenders must be supported by a Tender guarantee.
3. At the request of the Applicant, we, as Guarantor, hereby irrevocably undertake to pay the Beneficiary any sum or sums not exceeding in total an amount of _____ (_____) upon receipt by us of the Beneficiary's complying demand, supported by the Beneficiary's statement, whether in the demand itself or a separate signed document accompanying or identifying the demand, stating that either the Applicant:
 - (a) has withdrawn its Tender during the period of Tender validity set forth in the Applicant's Letter of Tender ("the Tender Validity Period"), or any extension thereto provided by the Applicant; or
 - b) having been notified of the acceptance of its Tender by the Beneficiary during the Tender Validity Period or any extension there to provided by the Applicant, (i) has failed to execute the contract agreement, or (ii) has failed to furnish the Performance.
4. This guarantee will expire: (a) if the Applicant is the successful Tenderer, upon our receipt of copies of the contract agreement signed by the Applicant and the Performance Security and, or (b) if the Applicant is not the successful Tenderer, upon the earlier of (i) our receipt of a copy of the Beneficiary's notification to the Applicant of the results of the Tendering process; or (ii) thirty days after the end of the Tender Validity Period.
5. Consequently, any demand for payment under this guarantee must be received by us at the office indicated above on or before that date.

[signature(s)]

Note: All italicized text is for use in preparing this form and shall be deleted from the final product.

FORMAT OF TENDER SECURITY [Option 2–Insurance Guarantee]

TENDER GUARANTEE No.: _____

1. Whereas [*Name of the tenderer*] (hereinafter called “the tenderer”) has submitted its tender dated [*Date of submission of tender*] for the.....[*Name and/or description of the tender*] (hereinafter called “the Tender”) for the execution of _____ under Request for Tenders No. _____ (“the ITT”).
2. KNOW ALL PEOPLE by these presents that WE of.....[**Name of Insurance Company**] having our registered office at (hereinafter called “the Guarantor”), are bound unto [*Name of Procuring Entity*] (hereinafter called “the Procuring Entity”) in the sum of (Currency and guarantee amount) for which payment well and truly to be made to the said Procuring Entity, the Guarantor binds itself, its successors and assigns, jointly and severally, firmly by these presents.

Sealed with the Common Seal of the said Guarantor this ___day of _____20 __.

3. NOW, THEREFORE, THE CONDITION OF THIS OBLIGATION is such that if the Applicant:
 - a) has withdrawn its Tender during the period of Tender validity set forth in the Principal's Letter of Tender (“the Tender Validity Period”), or any extension thereto provided by the Principal; or
 - b) having been notified of the acceptance of its Tender by the Procuring Entity during the Tender Validity Period or any extension thereto provided by the Principal; (i) failed to execute the Contract agreement; or (ii) has failed to furnish the Performance Security, in accordance with the Instructions to tenderers (“ITT”) of the Procuring Entity's Tendering document.

then the guarantee undertakes to immediately pay to the Procuring Entity up to the above amount upon receipt of the Procuring Entity's first written demand, without the Procuring Entity having to substantiate its demand, provided that in its demand the Procuring Entity shall state that the demand arises from the occurrence of any of the above events, specifying which event(s) has occurred.

4. This guarantee will expire: (a) if the Applicant is the successful Tenderer, upon our receipt of copies of the contract agreement signed by the Applicant and the Performance Security and, or (b) if the Applicant is not the successful Tenderer, upon the earlier of (i) our receipt of a copy of the Beneficiary's notification to the Applicant of the results of the Tendering process; or (ii) twenty-eight days after the end of the Tender Validity Period.
5. Consequently, any demand for payment under this guarantee must be received by us at the office indicated above on or before that date.

[Date]

[Witness]

[Signature of the Guarantor]

[Seal]

Note: All italicized text is for use in preparing this form and shall be deleted from the final product.

TENDER-SECURING DECLARATION FORM

[The Bidder shall complete this Form in accordance with the instructions indicated]

Date.....*[insert date (as day, month and year) of Tender Submission]*

Tender No..... *[insert number of tendering process]*

To:..... *[insert complete name of Purchaser]* I/We, the undersigned, declare that:

- 1. I/We understand that, according to your conditions, bids must be supported by a Tender-Securing Declaration.
- 2. I/We accept that I/we will automatically be suspended from being eligible for tendering in any contract with the Purchaser for the period of time of *[insert number of months or years]* starting on *[insert date]*, if we are in breach of our obligation(s) under the bid conditions, because we – (a) have withdrawn our tender during the period of tender validity specified by us in the Tendering Data Sheet; or (b) having been notified of the acceptance of our Bid by the Purchaser during the period of bid validity, (i) fail or refuse to execute the Contract, if required, or (ii) fail or refuse to furnish the Performance Security, in accordance with the instructions to tenders.
- 3. I/We understand that this Tender Securing Declaration shall expire if we are not the successful Tenderer(s), upon the earlier of:
 - a) our receipt of a copy of your notification of the name of the successful Tenderer; or
 - b) thirty days after the expiration of our Tender.
- 4. I/We understand that if I am/we are/in a Joint Venture, the Tender Securing Declaration must be in the name of the Joint Venture that submits the bid, and the Joint Venture has not been legally constituted at the time of bidding, the Tender Securing Declaration shall be in the names of all future partners as named in the letter of intent.

Signed.....Capacity / title (director
 or partner or sole proprietor, etc.) Name:
 Duly authorized to sign the bid
 for and on behalf of: *[insert complete name of Tenderer]*

Dated on day of.....*[Insert date of signing]* Seal or stamp

Appendix to Tender

Schedule of Currency requirements

Summary of currencies of the Tender for _____ *[insert name of Section of the Works]*

<i>Name of currency</i>	<i>Amounts payable</i>
Local currency: _____	
Foreign currency #1: _____	
Foreign currency #2: _____	
Foreign currency #3: _____	
Provisional sums expressed in local currency	[To be entered by the Procuring Entity]

PART II - WORK REQUIREMENTS

SECTION V - DRAWINGS

A list of drawings should be inserted here. The actual drawings including Site plans should be annexed in a separate booklet.

SECTION VI - SPECIFICATIONS

Notes for preparing Specifications

1. Specifications must be drafted to present a clear and precise statement of the required standards of materials, and workmanship for tenderers to respond realistically and competitively to the requirements of the Procuring Entity and ensure responsiveness of tenders. The Specifications should require that all materials, plant, and other supplies to be permanently incorporated in the Works be new, unused, of the most recent or current models, and incorporating all recent improvements in design and materials unless provided otherwise in the Contract. Where the Contractor is responsible for the design of any part of the permanent Works, the extent of his obligations must be stated.
 2. Specifications from previous similar projects are useful and may not be necessary to re-write specifications for every Works Contract.
 3. There are considerable advantages in standardizing **General Specifications** for repetitive Works in recognized public sectors, such as highways, urban housing, irrigation and water supply. The General Specifications should cover all classes of workmanship, materials and equipment commonly involved in constructions, although not necessarily to be used in a particular works contract. Deletions or addenda should then adapt the General Specifications to the particular Works.
 4. Care must be taken in drafting Specifications to ensure they are not restrictive. In the Specifications of standards for materials, plant and workmanship, existing Kenya Standards should be used as much as possible, otherwise recognized international standards may also be used.
 5. The Procuring Entity should decide whether technical solutions to specified parts of the Works are to be permitted. Alternatives are appropriate in cases where obvious (and potentially less costly) alternatives are possible to the technical solutions indicated in tender documents for certain elements of the Works, taking into consideration the comparative specialized advantage of potential tenderers.
 6. The Procuring Entity should provide a description of the selected parts of the Works with appropriate reference to Drawings, Specifications, Bills of Quantities, and Design or Performance criteria, stating that the alternative solutions shall be at least structurally and functionally equivalent to the basic design parameters and Specifications.
1. Such alternative solutions shall be accompanied by all information necessary for a complete evaluation by the Procuring Entity, including drawings, design calculations, technical specifications, breakdown of prices, proposed construction methodology, and other relevant details. Technical alternatives permitted in this manner shall be considered by the Procuring Entity each on its own merits and independently of whether the tenderer has priced the item as described in the Procuring Entity's design included with the tender documents.

SECTION VII- BILLS OF QUANTITIES

1. Objectives

The objectives of the Bill of Quantities are:

- a) to provide sufficient information on the quantities of Works to be performed to enable tenders to be prepared efficiently and accurately; and
- b) when a Contract has been entered into, to provide a priced Bill of Quantities for use in the periodic valuation of Works executed.

In order to attain these objectives, Works should be itemized in the Bill of Quantities in sufficient detail to distinguish between the different classes of Works, or between Works of the same nature carried out in different locations or in other circumstances which may give rise to different considerations of cost. Consistent with these requirements, the layout and contents of the Bill of Quantities should be as simple and brief as possible.

2. Day work Schedule

A Day work Schedule should be included only if the probability of unforeseen work, outside the items included in the Bill of Quantities, is high. To facilitate checking by the Procuring Entity of the realism of rates quoted by the Tenderers, the Day work Schedule should normally comprise the following:

- a) A list of the various classes of labor, materials, and Constructional Plant for which basic day work rates or prices are to be inserted by the Tenderer, together with a statement of the conditions under which the Contractor shall be paid for work executed on a day work basis.
- b) Nominal quantities for each item of day work, to be priced by each Tenderer at day work rates as Tender. The rate to be entered by the Tenderer against each basic day work item should include the Contractor's profit, overheads, supervision, and other charges.

3. Provisional Sums

A general provision for physical contingencies (quantity overruns) may be made by including a provisional sum in the Summary Bill of Quantities. Similarly, a contingency allowance for possible price increases should be provided as a provisional sum in the Summary priced Bill of Quantities. The inclusion of such provisional sums often facilitates budgetary approval by avoiding the need to request periodic supplementary approvals as the future need arises. Where such provisional sums or contingency allowances are used, the Special Conditions of Contract should state the manner in which they shall be used, and under whose authority (usually the Project Manager's).

The estimated cost of specialized work to be carried out, or of special goods to be supplied, by other contractors should be indicated in the relevant part of the Bill of Quantities as a particular provisional sum with an appropriate brief description. A separate procurement procedure is normally carried out by the Procuring Entity to select such specialized contractors. To provide an element of competition among the Tenderers in respect of any facilities, amenities, attendance, etc., to be provided by the successful Tenderer as prime Contractor for the use and convenience of the specialist contractors, each related provisional sum should be followed by an item in the Bill of Quantities inviting the Tenderer to quote a sum for such amenities, facilities, attendance, etc.

These Notes for Preparing a Bill of Quantities are intended only as information for the Procuring Entity or the person drafting the tendering document. They should not be included in the final tendering document.

4. The Bills of Quantities

The Bills of Quantities should be divided generally into the following sections:

- a) Preambles
- b) Preliminary items
- c) Work Items
- c) Daywork Schedule; and
- d) Provisional items
- e) Summary.

5. The Summary to the Bills of Quantities will take this form or some other form but including these items.

SUMMARY ITEMS	<i>Page</i>	<i>Amount</i>
Bill No. 1: Preliminary Items		
Bill No. 2: Work Items		
Bill No 3: Daywork Summary		
Bill No 4: Provisional Sums		
Subtotal of Bills No 1-4		
Allow for any Discounts ⁱ		
TOTAL TENDER PRICE Carried forward to Form of Tender		

**PART III - CONDITIONS OF CONTRACT
AND CONTRACT FORMS**

SECTION VIII - GENERAL CONDITIONS OF CONTRACT

These General Conditions of Contract (GCC), read in conjunction with the Special Conditions of Contract (SCC) and other documents listed therein, should be a complete document expressing fairly the rights and obligations of both parties.

These General Conditions of Contract have been developed on the basis of considerable international experience in the drafting and management of contracts, bearing in mind a trend in the construction industry towards simpler, more straightforward language.

The GCC can be used for both smaller admeasurement contracts and lump sum contracts.

General Conditions of Contract

A. General

1. Definitions

1.1 Bold face type is used to identify defined terms.

- a) **The Accepted Contract Amount** means the amount accepted in the Letter of Acceptance for the execution and completion of the Works and the remedying of any defects.
- b) **The Activity Schedule** is a schedule of the activities comprising the construction, installation, testing, and commissioning of the Works in a lump sum contract. It includes a lump sum price for each activity, which is used for valuations and for assessing the effects of Variations and Compensation Events.
- c) **The Adjudicator** is the person appointed jointly by the Procuring Entity and the Contractor to resolve disputes in the first instance, as provided for in GCC 23.
- d) **Bill of Quantities** means the priced and completed Bill of Quantities forming part of the Bid.
- e) **Compensation Events** are those defined in GCC Clause 42 hereunder.
- f) **The Completion Date** is the date of completion of the Works as certified by the Project Manager, in accordance with GCC Sub-Clause 53.1.
- g) **The Contract** is the Contract between the Procuring Entity and the Contractor to execute, complete, and maintain the Works. It consists of the documents listed in GCC Sub-Clause 2.3 below.
- h) **The Contractor** is the party whose Bid to carry out the Works has been accepted by the Procuring Entity.
- i) **The Contractor's Bid** is the completed bidding document submitted by the Contractor to the Procuring Entity.
- j) **The Contract Price** is the Accepted Contract Amount stated in the Letter of Acceptance and thereafter as adjusted in accordance with the Contract.
- k) **Days** are calendar days; months are calendar months.
- l) **Day works** are varied work inputs subject to payment on a time basis for the Contractor's employees and Equipment, in addition to payments for associated Materials and Plant.
- m) **A Defect** is any part of the Works not completed in accordance with the Contract.
- n) **The Defects Liability Certificate** is the certificate issued by Project Manager upon correction of defects by the Contractor.
- o) **The Defects Liability Period** is the period **named in the SCC** pursuant to Sub-Clause 34.1 and calculated from the Completion Date.
- p) **Drawings** means the drawings of the Works, as included in the Contract, and any additional and modified drawings issued by (or on behalf of) the Procuring Entity in accordance with the Contract, include calculations and other information provided or approved by the Project Manager for the execution of the Contract.
- q) **The Procuring Entity** is the party who employs the Contractor to carry out the Works, **as specified in the SCC**, who is also the Procuring Entity.
- r) **Equipment** is the Contractor's machinery and vehicles brought temporarily to the Site to construct the Works.

- s) **“In writing” or “written”** means hand-written, type-written, printed or electronically made, and resulting in a permanent record;
- t) The Initial Contract Price is the Contract Price listed in the Procuring Entity's Letter of Acceptance.
- u) **The Intended Completion Date** is the date on which it is intended that the Contractor shall complete the Works. The Intended Completion Date is **specified in the SCC**. The Intended Completion Date may be revised only by the Project Manager by issuing an extension of time or an acceleration order.
- v) **Materials** are all supplies, including consumables, used by the Contractor for incorporation in the Works.
- w) **Plant** is any integral part of the Works that shall have a mechanical, electrical, chemical, or biological function.
- x) **The Project Manager** is the person **named in the SCC** (or any other competent person appointed by the Procuring Entity and notified to the Contractor, to act in replacement of the Project Manager) who is responsible for supervising the execution of the Works and administering the Contract.
- y) **SCC** means Special Conditions of Contract.
- z) **The Site** is the area of the works as **defined as such in the SCC**.
- aa) **Site Investigation Reports** are those that were included in the bidding document and are factual and interpretative reports about the surface and subsurface conditions at the Site.
- ab) **Specification** means the Specification of the Works included in the Contract and any modification or addition made or approved by the Project Manager.
- ac) **The Start Date** is **given in the SCC**. It is the latest date when the Contractor shall commence execution of the Works. It does not necessarily coincide with any of the Site Possession Dates.
- ad) **A Subcontractor** is a person or corporate body who has a Contract with the Contractor to carry out a part of the work in the Contract, which includes work on the Site.
- ae) **Temporary Works** are works designed, constructed, installed, and removed by the Contractor that are needed for construction or installation of the Works.
- af) **A Variation** is an instruction given by the Project Manager which varies the Works.
- ag) **The Works** are what the Contract requires the Contractor to construct, install, and turn over to the Procuring Entity, **as defined in the SCC**.

2. Interpretation

- 21 In interpreting these GCC, words indicating one gender include all genders. Words indicating the singular also include the plural and words indicating the plural also include the singular. Headings have no significance. Words have their normal meaning under the language of the Contract unless specifically defined. The Project Manager shall provide instructions clarifying queries about these GCC.
- 22 If sectional completion is specified in the SCC, references in the GCC to the Works, the Completion Date, and the Intended Completion Date apply to any Section of the Works (other than references to the Completion Date and Intended Completion Date for the whole of the Works).
- 23 The documents forming the Contract shall be interpreted in the following order of priority:
 - a) Agreement,
 - b) Letter of Acceptance,
 - c) Contractor's Bid,
 - d) Special Conditions of Contract,
 - e) General Conditions of Contract, including Appendices,
 - f) Specifications,
 - g) Drawings,
 - h) Bill of Quantities⁶, and
 - i) any other document **listed in the SCC** as forming part of the Contract.

⁶In lump sum contracts, delete “Bill of Quantities” and replace with “Activity Schedule.”

3. Language and Law

- 31 The language of the Contract is English Language and the law governing the Contract are the Laws of Kenya.
- 32 Throughout the execution of the Contract, the Contractor shall comply with the import of goods and services prohibitions in the Procuring Entity's Country when
 - a) as a matter of law or official regulations, Kenya prohibits commercial relations with that country; or
 - b) by an act of compliance with a decision of the United Nations Security Council taken under Chapter VII of the Charter of the United Nations, Kenya prohibits any import of goods from that country or any payments to any country, person, or entity in that country.

4. Project Manager's Decisions

- 41 Except where otherwise specifically stated, the Project Manager shall decide contractual matters between the Procuring Entity and the Contractor in the role representing the Procuring Entity.

5. Delegation

- 51 Otherwise **specified in the SCC**, the Project Manager may delegate any of his duties and responsibilities to other people, except to the Adjudicator, after notifying the Contractor, and may revoke any delegation after notifying the Contractor.

6. Communications

- 61 Communications between parties that are referred to in the Conditions shall be effective only when in writing. A notice shall be effective only when it is delivered.

7. Subcontracting

- 71 The Contractor may subcontract with the approval of the Project Manager, but may not assign the Contract without the approval of the Procuring Entity in writing. Subcontracting shall not alter the Contractor's obligations.

8. Other Contractors

- 81 The Contractor shall cooperate and share the Site with other contractors, public authorities, utilities, and the Procuring Entity between the dates given in the Schedule of Other Contractors, as **referred to in the SCC**. The Contractor shall also provide facilities and services for them as described in the Schedule. The Procuring Entity may modify the Schedule of Other Contractors, and shall notify the Contractor of any such modification.

9. Personnel and Equipment

- 91 The Contractor shall employ the key personnel and use the equipment identified in its Bid, to carry out the Works or other personnel and equipment approved by the Project Manager. The Project Manager shall approve any proposed replacement of key personnel and equipment only if their relevant qualifications or characteristics are substantially equal to or better than those proposed in the Bid.
- 92 If the Project Manager asks the Contractor to remove a person who is a member of the Contractor's staff or work force, stating the reasons, the Contractor shall ensure that the person leaves the Site within seven days and has no further connection with the work in the Contract.
- 93 If the Procuring Entity, Project Manager or Contractor determines, that any employee of the Contractor be determined to have engaged in Fraud and Corruption during the execution of the Works, then that employee shall be removed in accordance with Clause 9.2 above.

10. Procuring Entity's and Contractor's Risks

- 101 The Procuring Entity carries the risks which this Contract states are Procuring Entity's risks, and the Contractor carries the risks which this Contract states are Contractor's risks.

11. Procuring Entity's Risks

- 11.1 From the Start Date until the Defects Liability Certificate has been issued, the following are Procuring Entity's risks:
- a) The risk of personal injury, death, or loss of or damage to property (excluding the Works, Plant, Materials, and Equipment), which are due to
 - i) use or occupation of the Site by the Works or for the purpose of the Works, which is the unavoidable result of the Works
 - ii) negligence, breach of statutory duty, or interference with any legal right by the Procuring Entity or by any person employed by or contracted to him except the Contractor.
 - b) The risk of damage to the Works, Plant, Materials, and Equipment to the extent that it is due to a fault of the Procuring Entity or in the Procuring Entity's design, or due to war or radioactive contamination directly affecting the country where the Works are to be executed.
- 11.2 From the Completion Date until the Defects Liability Certificate has been issued, the risk of loss of or damage to the Works, Plant, and Materials is a Procuring Entity's risk except loss or damage due to
- aa) a Defect which existed on the Completion Date,
 - ab) an event occurring before the Completion Date, which was not itself a Procuring Entity's risk, or
 - ac) the activities of the Contractor on the Site after the Completion Date.

12. Contractor's Risks

- 12.1 From the Starting Date until the Defects Liability Certificate has been issued, the risks of personal injury, death, and loss of or damage to property (including, without limitation, the Works, Plant, Materials, and Equipment) which are not Procuring Entity's risks are Contractor's risks.

13. Insurance

- 13.1 The Contractor shall provide, in the joint names of the Procuring Entity and the Contractor, insurance cover from the Start Date to the end of the Defects Liability Period, in the amounts and deductibles **stated in the SCC** for the following events which are due to the Contractor's risks:
- a) loss of or damage to the Works, Plant, and Materials;
 - b) loss of or damage to Equipment;
 - c) loss of or damage to property (except the Works, Plant, Materials, and Equipment) in connection with the Contract; and
 - d) personal injury or death.
- 13.2 Policies and certificates for insurance shall be delivered by the Contractor to the Project Manager for the Project Manager's approval before the Start Date. All such insurance shall provide for compensation to be payable in the types and proportions of currencies required to rectify the loss or damage incurred.
- 13.3 If the Contractor does not provide any of the policies and certificates required, the Procuring Entity may effect the insurance which the Contractor should have provided and recover the premiums the Procuring Entity has paid from payments otherwise due to the Contractor or, if no payment is due, the payment of the premiums shall be a debt due.
- 13.4 Alterations to the terms of an insurance shall not be made without the approval of the Project Manager.
- 13.5 Both parties shall comply with any conditions of the insurance policies.

14. Site Data

- 14.1 The Contractor shall be deemed to have examined any Site Data **referred to in the SCC**, supplemented by any information available to the Contractor.

15. Contractor to Construct the Works

- 15.1 The Contractor shall construct and install the Works in accordance with the Specifications and Drawings.

16. The Works to Be Completed by the Intended Completion Date

161 The Contractor may commence execution of the Works on the Start Date and shall carry out the Works in accordance with the Program submitted by the Contractor, as updated with the approval of the Project Manager, and complete them by the Intended Completion Date.

17. Approval by the Project Manager

171 The Contractor shall submit Specifications and Drawings showing the proposed Temporary Works to the Project Manager, for his approval.

172 The Contractor shall be responsible for design of Temporary Works.

173 The Project Manager's approval shall not alter the Contractor's responsibility for design of the Temporary Works.

174 The Contractor shall obtain approval of third parties to the design of the Temporary Works, where required.

175 All Drawings prepared by the Contractor for the execution of the temporary or permanent Works, are subject to prior approval by the Project Manager before this use.

18. Safety

181 The Contractor shall be responsible for the safety of all activities on the Site.

19. Discoveries

191 Anything of historical or other interest or of significant value unexpectedly discovered on the Site shall be the property of the Procuring Entity. The Contractor shall notify the Project Manager of such discoveries and carry out the Project Manager's instructions for dealing with them.

20. Possession of the Site

201 The Procuring Entity shall give possession of all parts of the Site to the Contractor. If possession of a part is not given by the date **stated in the SCC**, the Procuring Entity shall be deemed to have delayed the start of the relevant activities, and this shall be a Compensation Event.

21. Access to the Site

211 The Contractor shall allow the Project Manager and any person authorized by the Project Manager access to the Site and to any place where work in connection with the Contract is being carried out or is intended to be carried out.

22. Instructions, Inspections and Audits

221 The Contractor shall carry out all instructions of the Project Manager which comply with the applicable laws where the Site is located.

222 The Contractor shall keep, and shall make all reasonable efforts to cause its Subcontractors and sub-consultants to keep, accurate and systematic accounts and records in respect of the Works in such form and details as will clearly identify relevant time changes and costs.

223 The Contractor shall permit and shall cause its subcontractors and sub-consultants to permit, the Procuring Entity and/or persons appointed by the Public Procurement Regulatory Authority to inspect the Site and/or the accounts and records relating to the procurement process, selection and/or contract execution, and to have such accounts and records audited by auditors appointed by the Public Procurement Regulatory Authority. The Contractor's and its Subcontractors' and sub-consultants' attention is drawn to Sub-Clause 25.1 (Fraud and Corruption) which provides, inter alia, that acts intended to materially impede the exercise of the Public Procurement Regulatory Authority's inspection and audit rights constitute a prohibited practice subject to contract termination (as well as to a determination of ineligibility pursuant to the Public Procurement Regulatory Authority's prevailing sanctions procedures).

23. Appointment of the Adjudicator

- 23.1 The Adjudicator shall be appointed jointly by the Procuring Entity and the Contractor, at the time of the Procuring Entity's issuance of the Letter of Acceptance. If, in the Letter of Acceptance, the Procuring Entity does not agree on the appointment of the Adjudicator, the Procuring Entity will request the Appointing Authority designated in the SCC, to appoint the Adjudicator within 14 days of receipt of such request.
- 23.2 Should the Adjudicator resign or die, or should the Procuring Entity and the Contractor agree that the Adjudicator is not functioning in accordance with the provisions of the Contract, a new Adjudicator shall be jointly appointed by the Procuring Entity and the Contractor. In case of disagreement between the Procuring Entity and the Contractor, within 30 days, the Adjudicator shall be designated by the Appointing Authority designated in the SCC at the request of either party, within 14 days of receipt of such request.

24. Settlement of Claims and Disputes

24.1 Contractor's Claims

- 24.1.1 If the Contractor considers itself to be entitled to any extension of the Time for Completion and/or any additional payment, under any Clause of these Conditions or otherwise in connection with the Contract, the Contractor shall give Notice to the Project Manager, describing the event or circumstance giving rise to the claim. The notice shall be given as soon as practicable, and not later than 30 days after the Contractor became aware, or should have become aware, of the event or circumstance.
- 24.1.2 If the Contractor fails to give notice of a claim within such period of 30 days, the Time for Completion shall not be extended, the Contractor shall not be entitled to additional payment, and the Procuring Entity shall be discharged from all liability in connection with the claim. Otherwise, the following provisions of this Sub- Clause shall apply.
- 24.1.3 The Contractor shall also submit any other notices which are required by the Contract, and supporting particulars for the claim, all as relevant to such event or circumstance.
- 24.1.4 The Contractor shall keep such contemporary records as may be necessary to substantiate any claim, either on the Site or at another location acceptable to the Project Manager. Without admitting the Procuring Entity's liability, the Project Manager may, after receiving any notice under this Sub-Clause, monitor the record- keeping and/or instruct the Contractor to keep further contemporary records. The Contractor shall permit the Project Manager to inspect all these records, and shall (if instructed) submit copies to the Project Manager.
- 24.1.5 Within 42 days after the Contractor became aware (or should have become aware) of the event or circumstance giving rise to the claim, or within such other period as may be proposed by the Contractor and approved by the Project Manager, the Contractor shall send to the Project Manager a fully detailed claim which includes full supporting particulars of the basis of the claim and of the extension of time and/or additional payment claimed. If the event or circumstance giving rise to the claim has a continuing effect:
- a) this fully detailed claim shall be considered as interim;
 - b) the Contractor shall send further interim claims at monthly intervals, giving the accumulated delay and/or amount claimed, and such further particulars as the Project Manager may reasonably require; and
 - c) the Contractor shall send a final claim within 30 days after the end of the effects resulting from the event or circumstance, or within such other period as may be proposed by the Contractor and approved by the Project Manager.
- 24.1.6 Within 42 days after receiving a Notice of a claim or any further particulars supporting a previous claim, or within such other period as may be proposed by the Project Manager and approved by the Contractor, the Project Manager shall respond with approval, or with disapproval and detailed comments. He may also request any necessary further particulars, but shall nevertheless give his response on the principles of the claim within the above defined time period.
- 24.1.7 Within the above defined period of 42 days, the Project Manager shall proceed in accordance with Sub-Clause
- 24.1.8 [Determinations] to agree or determine (i) the extension (if any) of the Time for Completion (before or after its expiry) in accordance with Sub-Clause 8.4 [Extension of Time for Completion], and/or (ii) the

additional payment (if any) to which the Contractor is entitled under the Contract.

24.1.9 Each Payment Certificate shall include such additional payment for any claim as has been reasonably substantiated as due under the relevant provision of the Contract. Unless and until the particulars supplied are sufficient to substantiate the whole of the claim, the Contractor shall only be entitled to payment for such part of the claim as he has been able to substantiate.

24.1.10 If the Project Manager does not respond within the timeframe defined in this Clause, either Party may consider that the claim is rejected by the Project Manager and any of the Parties may refer to Arbitration in accordance with Sub-Clause 24.4 [Arbitration].

24.1.11 The requirements of this Sub-Clause are in addition to those of any other Sub-Clause which may apply to a claim. If the Contractor fails to comply with this or another Sub-Clause in relation to any claim, any extension of time and/or additional payment shall take account of the extent (if any) to which the failure has prevented or prejudiced proper investigation of the claim, unless the claim is excluded under the second paragraph of this Sub-Clause 24.3.

242 Amicable Settlement

24.2.1 Where a notice of a claim has been given, both Parties shall attempt to settle the dispute amicably before the commencement of arbitration. However, unless both Parties agree otherwise, the Party giving a notice of a claim in accordance with Sub-Clause 24.1 above should move to commence arbitration after the fifty-sixth day from the day on which a notice of a claim was given, even if no attempt at an amicable settlement has been made.

243 Matters that may be referred to arbitration

24.3.1 Notwithstanding anything stated herein the following matters may be referred to arbitration before the practical completion of the Works or abandonment of the Works or termination of the Contract by either party:

- a) The appointment of a replacement Project Manager upon the said person ceasing to act.
- b) Whether or not the issue of an instruction by the Project Manager is empowered by these Conditions.
- c) Whether or not a certificate has been improperly withheld or is not in accordance with these Conditions.
- e) Any dispute arising in respect of war risks or war damage.
- f) All other matters shall only be referred to arbitration after the completion or alleged completion of the Works or termination or alleged termination of the Contract, unless the Procuring Entity and the Contractor agree otherwise in writing.

244 Arbitration

24.4.1 Any claim or dispute between the Parties arising out of or in connection with the Contract not settled amicably in accordance with Sub-Clause 24.3 shall be finally settled by arbitration.

24.4.2 No arbitration proceedings shall be commenced on any claim or dispute where notice of a claim or dispute has not been given by the applying party within ninety days of the occurrence or discovery of the matter or issue giving rise to the dispute.

24.4.3 Notwithstanding the issue of a notice as stated above, the arbitration of such a claim or dispute shall not commence unless an attempt has in the first instance been made by the parties to settle such claim or dispute amicably with or without the assistance of third parties. Proof of such attempt shall be required.

24.4.4 The Arbitrator shall, without prejudice to the generality of his powers, have powers to direct such measurements, computations, tests or valuations as may in his opinion be desirable in order to determine the rights of the parties and assess and award any sums which ought to have been the subject of or included in any certificate.

24.4.5 The Arbitrator shall, without prejudice to the generality of his powers, have powers to open up, review and revise any certificate, opinion, decision, requirement or notice and to determine all matters in dispute which shall be submitted to him in the same manner as if no such certificate, opinion, decision requirement or notice had been given.

24.4.6 The arbitrators shall have full power to open up, review and revise any certificate, determination, instruction, opinion or valuation of the Project Manager, relevant to the dispute. Nothing shall disqualify representatives of the Parties and the Project Manager from being called as a witness and giving evidence before the arbitrators on any matter whatsoever relevant to the dispute.

24.4.7 Neither Party shall be limited in the proceedings before the arbitrators to the evidence, or to the reasons for dissatisfaction given in its Notice of Dissatisfaction.

24.4.8 Arbitration may be commenced prior to or after completion of the Works. The obligations of the Parties, and the Project Manager shall not be altered by reason of any arbitration being conducted during the progress of the Works.

24.4.9 The terms of the remuneration of each or all the members of Arbitration shall be mutually agreed upon by the

Parties when agreeing the terms of appointment. Each Party shall be responsible for paying one-half of this remuneration.

245 Arbitration with National Contractors

24.5.1 If the Contract is with national contractors, arbitration proceedings will be conducted in accordance with the Arbitration Laws of Kenya. In case of any claim or dispute, such claim or dispute shall be notified in writing by either party to the other with a request to submit it to arbitration and to concur in the appointment of an Arbitrator within thirty days of the notice. The dispute shall be referred to the arbitration and final decision of a person to be agreed between the parties. Failing agreement to concur in the appointment of an Arbitrator, the Arbitrator shall be appointed, on the request of the applying party, by the Chairman or Vice Chairman of any of the following professional institutions;

- i) Architectural Association of Kenya
- ii) Institute of Quantity Surveyors of Kenya
- iii) Association of Consulting Engineers of Kenya
- iv) Chartered Institute of Arbitrators (Kenya Branch)
- v) Institution of Engineers of Kenya

24.5.2 The institution written to first by the aggrieved party shall take precedence over all other institutions.

246 Alternative Arbitration Proceedings

24.6.1 Alternatively, the Parties may refer the matter to the Nairobi Centre for International Arbitration (NCIA) which offers a neutral venue for the conduct of national and international arbitration with commitment to providing institutional support to the arbitral process.

247 Failure to Comply with Arbitrator's Decision

24.7.1 The award of such Arbitrator shall be final and binding upon the parties.

24.7.2 In the event that a Party fails to comply with a final and binding Arbitrator's decision, then the other Party may, without prejudice to any other rights it may have, refer the matter to a competent court of law.

248 Contract operations to continue

24.8.1 Notwithstanding any reference to arbitration herein,

- a) the parties shall continue to perform their respective obligations under the Contract unless they otherwise agree; and
- b) the Procuring Entity shall pay the Contractor any monies due the Contractor.

25. Fraud and Corruption

25.1 The Government requires compliance with the country's Anti-Corruption laws and its prevailing sanctions policies and procedures as set forth in the Constitution of Kenya and its Statutes.

25.2 The Procuring Entity requires the Contractor to disclose any commissions or fees that may have been paid or are to be paid to agents or any other party with respect to the bidding process or execution of the Contract. The information disclosed must include at least the name and address of the agent or other party, the amount and currency, and the purpose of the commission, gratuity or fee.

B. Time Control

26. Program

26.1 Within the time stated in the SCC, after the date of the Letter of Acceptance, the Contractor shall submit to the Project Manager for approval a Program showing the general methods, arrangements, order, and timing for all the activities in the Works. In the case of a lump sum contract, the activities in the Program shall be consistent with those in the Activity Schedule.

26.2 An update of the Program shall be a program showing the actual progress achieved on each activity and the effect of the progress achieved on the timing of the remaining work, including any changes to the sequence of the activities.

26.3 The Contractor shall submit to the Project Manager for approval an updated Program at intervals no longer than the period stated in the SCC. If the Contractor does not submit an updated Program within this period, the Project Manager may withhold the amount stated in the SCC from the next payment certificate and

continue to withhold this amount until the next payment after the date on which the overdue Program has been submitted. In the case of a lump sum contract, the Contractor shall provide an updated Activity Schedule within 14 days of being instructed to by the Project Manager.

264 The Project Manager's approval of the Program shall not alter the Contractor's obligations. The Contractor may revise the Program and submit it to the Project Manager again at any time. A revised Program shall show the effect of Variations and Compensation Events.

27. Extension of the Intended Completion Date

271 The Project Manager shall extend the Intended Completion Date if a Compensation Event occurs or a Variation is issued which makes it impossible for Completion to be achieved by the Intended Completion Date without the Contractor taking steps to accelerate the remaining work, which would cause the Contractor to incur additional cost.

272 The Project Manager shall decide whether and by how much to extend the Intended Completion Date within 21 days of the Contractor asking the Project Manager for a decision upon the effect of a Compensation Event or Variation and submitting full supporting information. If the Contractor has failed to give early warning of a delay or has failed to cooperate in dealing with a delay, the delay by this failure shall not be considered in assessing the new Intended Completion Date.

28. Acceleration

281 When the Procuring Entity wants the Contractor to finish before the Intended Completion Date, the Project Manager shall obtain priced proposals for achieving the necessary acceleration from the Contractor. If the Procuring Entity accepts these proposals, the Intended Completion Date shall be adjusted accordingly and confirmed by both the Procuring Entity and the Contractor.

282 If the Contractor's priced proposals for an acceleration are accepted by the Procuring Entity, they are incorporated in the Contract Price and treated as a Variation.

29. Delays Ordered by the Project Manager

291 The Project Manager may instruct the Contractor to delay the start or progress of any activity within the Works.

30. Management Meetings

301 Either the Project Manager or the Contractor may require the other to attend a management meeting. The business of a management meeting shall be to review the plans for remaining work and to deal with matters raised in accordance with the early warning procedure.

302 The Project Manager shall record the business of management meetings and provide copies of the record to those attending the meeting and to the Procuring Entity. The responsibility of the parties for actions to be taken shall be decided by the Project Manager either at the management meeting or after the management meeting and stated in writing to all who attended the meeting.

31. Early Warning

311 The Contractor shall warn the Project Manager at the earliest opportunity of specific likely future events or circumstances that may adversely affect the quality of the work, increase the Contract Price, or delay the execution of the Works. The Project Manager may require the Contractor to provide an estimate of the expected effect of the future event or circumstance on the Contract Price and Completion Date. The estimate shall be provided by the Contractor as soon as reasonably possible.

312 The Contractor shall cooperate with the Project Manager in making and considering proposals for how the effect of such an event or circumstance can be avoided or reduced by anyone involved in the work and in carrying out any resulting instruction of the Project Manager.

C. Quality Control

32. Identifying Defects

321 The Project Manager shall check the Contractor's work and notify the Contractor of any Defects that are found. Such checking shall not affect the Contractor's responsibilities. The Project Manager may instruct the Contractor to search for a Defect and to uncover and test any work that the Project Manager considers may have a Defect.

33. Tests

- 33.1 If the Project Manager instructs the Contractor to carry out a test not specified in the Specification to check whether any work has a Defect and the test shows that it does, the Contractor shall pay for the test and any samples. If there is no Defect, the test shall be a Compensation Event.

34. Correction of Defects

- 34.1 The Project Manager shall give notice to the Contractor of any Defects before the end of the Defects Liability Period, which begins at Completion, and is defined in the SCC. The Defects Liability Period shall be extended for as long as Defects remain to be corrected.
- 34.2 Every time notice of a Defect is given, the Contractor shall correct the notified Defect within the length of time specified by the Project Manager's notice.

35. Uncorrected Defects

- 35.1 If the Contractor has not corrected a Defect within the time specified in the Project Manager's notice, the Project Manager shall assess the cost of having the Defect corrected, and the Contractor shall pay this amount.

D. Cost Control

36. Contract Price⁷

- 36.1 The Bill of Quantities shall contain priced items for the Works to be performed by the Contractor. The Bill of Quantities is used to calculate the Contract Price. The Contractor will be paid for the quantity of the work accomplished at the rate in the Bill of Quantities for each item.

37. Changes in the Contract Price⁸

- 37.1 If the final quantity of the work done differs from the quantity in the Bill of Quantities for the particular item by more than 25 percent, provided the change exceeds 1 percent of the Initial Contract Price, the Project Manager shall adjust the rate to allow for the change. The Project Manager shall not adjust rates from changes in quantities if thereby the Initial Contract Price is exceeded by more than 15 percent, except with the prior approval of the Procuring Entity.
- 37.2 If requested by the Project Manager, the Contractor shall provide the Project Manager with a detailed cost breakdown of any rate in the Bill of Quantities.

38. Variations

- 38.1 All Variations shall be included in updated Programs⁹ produced by the Contractor.
- 38.2 The Contractor shall provide the Project Manager with a quotation for carrying out the Variation when requested to do so by the Project Manager. The Project Manager shall assess the quotation, which shall be given within seven (7) days of the request or within any longer period stated by the Project Manager and before the Variation is ordered.
- 38.3 If the Contractor's quotation is unreasonable, the Project Manager may order the Variation and make a change to the Contract Price, which shall be based on the Project Manager's own forecast of the effects of the Variation on the Contractor's costs.
- 38.4 If the Project Manager decides that the urgency of varying the work would prevent a quotation being given and considered without delaying the work, no quotation shall be given and the Variation shall be treated as a Compensation Event.

⁷In lump sum contracts, replace GCC Sub-Clauses 36.1 as follows:

36.1 The Contractor shall provide updated Activity Schedules within 14 days of being instructed to by the Project Manager. The Activity Schedule shall contain the priced activities for the Works to be performed by the Contractor. The Activity Schedule is used to monitor and control the performance of activities on which basis the Contractor will be paid. If payment for materials on site shall be made separately, the Contractor shall show delivery of Materials to the Site separately on the Activity Schedule.

⁸In lump sum contracts, replace entire GCC Clause 37 with new GCC Sub-Clause 37.1, as follows:

The Activity Schedule shall be amended by the Contractor to accommodate changes of Program or method of working made at the Contractor's own discretion. Prices in the Activity Schedules shall not be altered when the Contractor makes such changes to the Activity Schedule.

⁹In lump sum contracts, add "and Activity Schedules" after "Programs." ¹⁰In lump sum contracts, delete this paragraph.

- 385 The Contractor shall not be entitled to additional payment for costs that could have been avoided by giving early warning
- 386 If the work in the Variation corresponds to an item description in the Bill of Quantities and if, in the opinion of the Project Manager, the quantity of work above the limit stated in Sub-Clause 39.1 or the timing of its execution do not cause the cost per unit of quantity to change, the rate in the Bill of Quantities shall be used to calculate the value of the Variation. If the cost per unit of quantity changes, or if the nature or timing of the work in the Variation does not correspond with items in the Bill of Quantities, the quotation by the Contractor shall be in the form of new rates for the relevant items of work
- 387 Value Engineering: The Contractor may prepare, at its own cost, a value engineering proposal at any time during the performance of the contract. The value engineering proposal shall, at a minimum, include the following;
- a) the proposed change(s), and a description of the difference to the existing contract requirements;
 - b) a full cost/benefit analysis of the proposed change(s) including a description and estimate of costs (including life cycle costs) the Procuring Entity may incur in implementing the value engineering proposal; and
 - c) a description of any effect(s) of the change on performance/functionality.
- 388 The Procuring Entity may accept the value engineering proposal if the proposal demonstrates benefits that:
- a) accelerate the contract completion period; or
 - b) reduce the Contract Price or the life cycle costs to the Procuring Entity; or
 - c) improve the quality, efficiency, safety or sustainability of the Facilities; or
 - d) yield any other benefits to the Procuring Entity, without compromising the functionality of the Works.
- 389 If the value engineering proposal is approved by the Procuring Entity and results in:
- a) a reduction of the Contract Price; the amount to be paid to the Contractor shall be the **percentage specified in the SCC** of the reduction in the Contract Price; or
 - b) an increase in the Contract Price; but results in a reduction in life cycle costs due to any benefit described in (a) to (d) above, the amount to be paid to the Contractor shall be the full increase in the Contract Price.

39. Cash Flow Forecasts

- 391 When the Program¹¹, is updated, the Contractor shall provide the Project Manager with an updated cash flow forecast. The cash flow forecast shall include different currencies, as defined in the Contract, converted as necessary using the Contract exchange rates.

40. Payment Certificates

- 401 The Contractor shall submit to the Project Manager monthly statements of the estimated value of the work executed less the cumulative amount certified previously.
- 402 The Project Manager shall check the Contractor's monthly statement and certify the amount to be paid to the Contractor.
- 403 The value of work executed shall be determined by the Project Manager.
- 404 The value of work executed shall comprise the value of the quantities of work in the Bill of Quantities that have been completed¹².
- 405 The value of work executed shall include the valuation of Variations and Compensation Events.
- 406 The Project Manager may exclude any item certified in a previous certificate or reduce the proportion of any item previously certified in any certificate in the light of later information.
- 407 Where the contract price is different from the corrected tender price, in order to ensure the contractor is not paid less or more relative to the contract price (which would be the tender price), payment valuation certificates and variation orders on omissions and additions valued based on rates in the Bill of Quantities or schedule of rates in the Tender, will be adjusted by a plus or minus percentage. The percentage already worked out during tender evaluation is worked out as follows: $(\text{corrected tender price} - \text{tender price}) / \text{tender price} \times 100$.

41. Payments

- 41.1 Payments shall be adjusted for deductions for advance payments and retention. The Procuring Entity shall pay the Contractor the amounts certified by the Project Manager within 30 days of the date of each certificate. If the Procuring Entity makes a late payment, the Contractor shall be paid interest on the late payment in the next payment. Interest shall be calculated from the date by which the payment should have been made up to the date when the late payment is made at the prevailing rate of interest for commercial borrowing for each of the currencies in which payments are made.
- 41.2 If an amount certified is increased in a later certificate or as a result of an award by the Adjudicator or an Arbitrator, the Contractor shall be paid interest upon the delayed payment as set out in this clause. Interest shall be calculated from the date upon which the increased amount would have been certified in the absence of dispute.
- 41.3 Unless otherwise stated, all payments and deductions shall be paid or charged in the proportions of currencies comprising the Contract Price.
- 41.4 Items of the Works for which no rate or price has been entered in shall not be paid for by the Procuring Entity and shall be deemed covered by other rates and prices in the Contract.

42. Compensation Events

42.1 The following shall be Compensation Events:

- d) The Procuring Entity does not give access to a part of the Site by the Site Possession Date pursuant to GCC Sub-Clause 20.1.
- e) The Procuring Entity modifies the Schedule of Other Contractors in a way that affects the work of the Contractor under the Contract.
- f) The Project Manager orders a delay or does not issue Drawings, Specifications, or instructions required for execution of the Works on time.
- g) The Project Manager instructs the Contractor to uncover or to carry out additional tests upon work, which is then found to have no Defects.
- h) The Project Manager unreasonably does not approve a subcontract to be let.
- i) Ground conditions are substantially more adverse than could reasonably have been assumed before issuance of the Letter of Acceptance from the information issued to bidders (including the Site Investigation Reports), from information available publicly and from a visual inspection of the Site.
- j) The Project Manager gives an instruction for dealing with an unforeseen condition, caused by the Procuring Entity, or additional work required for safety or other reasons.
- k) Other contractors, public authorities, utilities, or the Procuring Entity does not work within the dates and other constraints stated in the Contract, and they cause delay or extra cost to the Contractor.
- l) The advance payment is delayed.
- m) The effects on the Contractor of any of the Procuring Entity's Risks.
- n) The Project Manager unreasonably delays issuing a Certificate of Completion.

42.2 If a Compensation Event would cause additional cost or would prevent the work being completed before the Intended Completion Date, the Contract Price shall be increased and/or the Intended Completion Date shall be extended. The Project Manager shall decide whether and by how much the Contract Price shall be increased and whether and by how much the Intended Completion Date shall be extended.

42.3 As soon as information demonstrating the effect of each Compensation Event upon the Contractor's forecast cost has been provided by the Contractor, it shall be assessed by the Project Manager, and the Contract Price shall be adjusted accordingly. If the Contractor's forecast is deemed unreasonable, the Project Manager shall adjust the Contract Price based on the Project Manager's own forecast. The Project Manager shall assume that the Contractor shall react competently and promptly to the event.

¹¹In lump sum contracts, add "or Activity Schedule" after "Program."

¹²In lump sum contracts, replace this paragraph with the following: "The value of work executed shall comprise the value of completed activities in the Activity Schedule."

424 The Contractor shall not be entitled to compensation to the extent that the Procuring Entity's interests are adversely affected by the Contractor's not having given early warning or not having cooperated with the Project Manager.

43. Tax

431 The Project Manager shall adjust the Contract Price if taxes, duties, and other levies are changed between the date 30 days before the submission of bids for the Contract and the date of the last Completion certificate. The adjustment shall be the change in the amount of tax payable by the Contractor, provided such changes are not already reflected in the Contract Price or are a result of GCC Clause 44.

44. Currency of Payment

441 All payments under the contract shall be made in Kenya Shillings

45. Price Adjustment

451 Prices shall be adjusted for fluctuations in the cost of inputs only if **provided for in the SCC**. If so provided, the amounts certified in each payment certificate, before deducting for Advance Payment, shall be adjusted by applying the respective price adjustment factor to the payment amounts due in each currency. A separate formula of the type specified below applies:

$$P = A + B I_m/I_o$$

where:

the Contract Price payable.

P is the adjustment factor for the portion of

A and B are coefficients¹³ **specified in the SCC**, representing the non-adjustable and adjustable portions, respectively, of the Contract Price payable and I_m is the index prevailing at the end of the month being invoiced and I_o is the index prevailing 30 days before Bid opening for inputs payable.

452 If the value of the index is changed after it has been used in a calculation, the calculation shall be corrected and an adjustment made in the next payment certificate. The index value shall be deemed to take account of all changes in cost due to fluctuations in costs.

46. Retention

461 The Procuring Entity shall retain from each payment due to the Contractor the proportion stated in the **SCC** until Completion of the whole of the Works.

462 Upon the issue of a Certificate of Completion of the Works by the Project Manager, in accordance with GCC 53.1, half the total amount retained shall be repaid to the Contractor and half when the Defects Liability Period has passed and the Project Manager has certified that all Defects notified by the Project Manager to the Contractor before the end of this period have been corrected. The Contractor may substitute retention money with an "on demand" Bank guarantee.

47. Liquidated Damages

471 The Contractor shall pay liquidated damages to the Procuring Entity at the rate per day stated in the **SCC** for each day that the Completion Date is later than the Intended Completion Date. The total amount of liquidated damages shall not exceed the amount defined in the SCC. The Procuring Entity may deduct liquidated damages from payments due to the Contractor. Payment of liquidated damages shall not affect the Contractor's liabilities.

472 If the Intended Completion Date is extended after liquidated damages have been paid, the Project Manager shall correct any overpayment of liquidated damages by the Contractor by adjusting the next payment certificate. The Contractor shall be paid interest on the overpayment, calculated from the date of payment to the date of repayment, at the rates specified in GCC Sub-Clause 41.1.

48. Bonus

481 The Contractor shall be paid a Bonus calculated at the rate per calendar day **stated in the SCC** for each day (less any days for which the Contractor is paid for acceleration) that the Completion is earlier than the Intended Completion Date. The Project Manager shall certify that the Works are complete, although they may not be due to be complete.

49. Advance Payment

- 49.1 The Procuring Entity shall make advance payment to the Contractor of the amounts stated in the SCC by the date stated in the SCC, against provision by the Contractor of an Unconditional Bank Guarantee in a form and by a bank acceptable to the Procuring Entity in amounts and currencies equal to the advance payment. The Guarantee shall remain effective until the advance payment has been repaid, but the amount of the Guarantee shall be progressively reduced by the amounts repaid by the Contractor. Interest shall not be charged on the advance payment.
- 49.2 The Contractor is to use the advance payment only to pay for Equipment, Plant, Materials, and mobilization expenses required specifically for execution of the Contract. The Contractor shall demonstrate that advance payment has been used in this way by supplying copies of invoices or other documents to the Project Manager.
- 49.3 The advance payment shall be repaid by deducting proportionate amounts from payments otherwise due to the Contractor, following the schedule of completed percentages of the Works on a payment basis. No account shall be taken of the advance payment or its repayment in assessing valuations of work done, Variations, price adjustments, Compensation Events, Bonuses, or Liquidated Damages.

50. Securities

- 50.1 The Performance Security shall be provided to the Procuring Entity no later than the date specified in the Letter of Acceptance and shall be issued in an amount **specified in the SCC**, by a bank or surety acceptable to the Procuring Entity, and denominated in the types and proportions of the currencies in which the Contract Price is payable. The Performance Security shall be valid until a date 28 day from the date of issue of the Certificate of Completion in the case of a Bank Guarantee, and until one year from the date of issue of the Completion Certificate in the case of a Performance Bond.

51. Dayworks

- 51.1 If applicable, the Dayworks rates in the Contractor's Bid shall be used only when the Project Manager has given written instructions in advance for additional work to be paid for in that way.
- 51.2 All work to be paid for as Dayworks shall be recorded by the Contractor on forms approved by the Project Manager. Each completed form shall be verified and signed by the Project Manager within two days of the work being done.
- 51.3 The Contractor shall be paid for Dayworks subject to obtaining signed Dayworks forms.

52. Cost of Repairs

- 52.1 Loss or damage to the Works or Materials to be incorporated in the Works between the Start Date and the end of the Defects Correction periods shall be remedied by the Contractor at the Contractor's cost if the loss or damage arises from the Contractor's acts or omissions.

E. Finishing the Contract

53. Completion

- 53.1 The Contractor shall request the Project Manager to issue a Certificate of Completion of the Works, and the Project Manager shall do so upon deciding that the whole of the Works is completed.

54. Taking Over

- 54.1 The Procuring Entity shall take over the Site and the Works within seven days of the Project Manager's issuing a certificate of Completion.

55. Final Account

- 55.1 The Contractor shall supply the Project Manager with a detailed account of the total amount that the Contractor considers payable under the Contract before the end of the Defects Liability Period. The Project Manager shall issue a Defects Liability Certificate and certify any final payment that is due to the Contractor within 56 days of receiving the Contractor's account if it is correct and complete. If it is not, the Project Manager shall issue within 56 days a schedule that states the scope of the corrections or additions that are necessary. If the Final Account is still unsatisfactory after it has been resubmitted, the Project Manager shall decide on the amount payable to the Contractor and issue a payment certificate.

¹³The sum of the two coefficients A and B should be 1 (one) in the formula for each currency. Normally, both coefficients shall be the same in the formulae for all currencies, since coefficient A, for the non-adjustable portion of the payments, is a very approximate figure (usually 0.15) to take account of fixed cost elements or other non-adjustable components. The sum of the adjustments for each currency are added to the Contract Price.

56. Operating and Maintenance Manuals

- 56.1 If “as built” Drawings and/or operating and maintenance manuals are required, the Contractor shall supply them by the dates stated in the SCC.
- 56.2 If the Contractor does not supply the Drawings and/or manuals by the dates stated in the SCC pursuant to GCC Sub-Clause 56.1, or they do not receive the Project Manager's approval, the Project Manager shall withhold the amount **stated in the SCC** from payments due to the Contractor.

57. Termination

- 57.1 The Procuring Entity or the Contractor may terminate the Contract if the other party causes a fundamental breach of the Contract.
- 57.2 Fundamental breaches of Contract shall include, but shall not be limited to, the following:
- a) the Contractor stops work for 30 days when no stoppage of work is shown on the current Program and the stoppage has not been authorized by the Project Manager;
 - b) the Project Manager instructs the Contractor to delay the progress of the Works, and the instruction is not withdrawn within 30 days;
 - c) the Procuring Entity or the Contractor is made bankrupt or goes into liquidation other than for a reconstruction or amalgamation;
 - d) a payment certified by the Project Manager is not paid by the Procuring Entity to the Contractor within 84 days of the date of the Project Manager's certificate;
 - e) the Project Manager gives Notice that failure to correct a particular Defect is a fundamental breach of Contract and the Contractor fails to correct it within a reasonable period of time determined by the Project Manager;
 - f) the Contractor does not maintain a Security, which is required;
 - g) the Contractor has delayed the completion of the Works by the number of days for which the maximum amount of liquidated damages can be paid, as **defined in the SCC**; or
 - h) if the Contractor, in the judgment of the Procuring Entity has engaged in Fraud and Corruption, as defined in paragraph 2.2 a of the Appendix A to the GCC, in competing for or in executing the Contract, then the Procuring Entity may, after giving fourteen (14) days written notice to the Contractor, terminate the Contract and expel him from the Site.
- 57.3 Notwithstanding the above, the Procuring Entity may terminate the Contract for convenience.
- 57.4 If the Contract is terminated, the Contractor shall stop work immediately, make the Site safe and secure, and leave the Site as soon as reasonably possible.
- 57.5 When either party to the Contract gives notice of a breach of Contract to the Project Manager for a cause other than those listed under GCC Sub-Clause 56.2 above, the Project Manager shall decide whether the breach is fundamental or not.

58. Payment upon Termination

- 58.1 If the Contract is terminated because of a fundamental breach of Contract by the Contractor, the Project Manager shall issue a certificate for the value of the work done and Materials ordered less advance payments received up to the date of the issue of the certificate and less the percentage to apply to the value of the work not completed, as specified in the SCC. Additional Liquidated Damages shall not apply. If the total amount due to the Procuring Entity exceeds any payment due to the Contractor, the difference shall be a debt payable to the Procuring Entity.
- 58.2 If the Contract is terminated for the Procuring Entity's convenience or because of a fundamental breach of Contract by the Procuring Entity, the Project Manager shall issue a certificate for the value of the work done, Materials ordered, the reasonable cost of removal of Equipment, repatriation of the Contractor's personnel employed solely on the Works, and the Contractor's costs of protecting and securing the Works, and less advance payments received up to the date of the certificate.

59. Property

- 59.1 All Materials on the Site, Plant, Equipment, Temporary Works, and Works shall be deemed to be the property of the Procuring Entity if the Contract is terminated because of the Contractor's default.

60. Release from Performance

- 60.1 If the Contract is frustrated by the outbreak of war or by any other event entirely outside the control of either the Procuring Entity or the Contractor, the Project Manager shall certify that the Contract has been frustrated. The Contractor shall make the Site safe and stop work as quickly as possible after receiving this certificate and shall be paid for all work carried out before receiving it and for any work carried out afterwards to which a commitment was made.

SECTION IX - SPECIAL CONDITIONS OF CONTRACT

Except where otherwise specified, all Special Conditions of Contract should be filled in by the Procuring Entity prior to issuance of the bidding document. Schedules and reports to be provided by the Procuring Entity should be annexed.

Number of GC Clause	Amendments of, and Supplements to, Clauses in the General Conditions of Contract
A. General	
GCC 1.1 (q)	The Procuring Entity is <i>[insert name, address, and name of authorized representative]</i> .
GCC 1.1 (u)	The Intended Completion Date for the whole of the Works shall be Four Months FROM COMMENCEMENT DATE <i>[If different dates are specified for completion of the Works by section (“sectional completion” or milestones), these dates should be listed here]</i>
GCC 1.1 (z)	The Site is located at Kombe school in Chesumei Constituency
GCC 1.1 (cc)	The Start Date shall be as agreed with the Project manager (PM)
GCC 1.1 (gg)	The Works consist of AS PER DWGS, BQS,
GCC 2.2	Sectional Completions are: N/A <i>[insert nature and dates, if appropriate]</i>
GCC 5.1	The Project manager MAY DELEGATE any of his duties and responsibilities.
GCC 8.1	Schedule of other contractors: <i>[insert Schedule of Other Contractors, if appropriate]</i>
GCC 9.1	Key Personnel -N/A GCC 9.1 is replaced with the following: 9.1 Key Personnel are the Contractor’s personnel named in this GCC 9.1 of the Special Conditions of Contract. The Contractor shall employ the Key Personnel and use the equipment identified in its Bid, to carry out the Works or other personnel and equipment approved by the Project Manager. The Project Manager shall approve any proposed replacement of Key Personnel and equipment only if their relevant qualifications or characteristics are substantially equal to or better than those proposed in the Bid. <i>[insert the name/s of each Key Personnel agreed by the Procuring Entity prior to Contract signature.]</i>
GCC 13.1	The minimum insurance amounts and deductibles shall be: for loss or damage to the Works, Plant and Materials: 2.5% <i>[insert amounts]</i> . For loss or damage to Equipment: 2.5% <i>[insert amounts]</i> . for loss or damage to property (except the Works, Plant, Materials, and Equipment) in connection with Contract 2.5% <i>[insert amounts]</i> . (d) for personal injury or death: (i) of the Contractor’s employees: 2% <i>[amount]</i> . (ii) of other people: 2% <i>[amount]</i> .
GCC 14.1	Site Data are: <i>[list Site Data]</i>
GCC 20.1	The Site Possession Date(s) shall be: TO BE COMMUNICATED BY PM
GCC 23.1 &	Appointing Authority for the Adjudicator: ACCOUNTING OFFICER
Number of GC Clause	Amendments of, and Supplements to, Clauses in the General Conditions of Contract
GCC 23.2	

	Hourly rate and types of reimbursable expenses to be paid to the Adjudicator: TO BE DETERMINED <i>[insert hourly fees and reimbursable expenses]</i> .
B. Time Control	
GCC 26.1	The Contractor shall submit for approval a Program for the Works within 7 DAYS from the date of the Letter of Acceptance.
GCC 26.3	The period between Program updates is 7 DAYS. The amount to be withheld for late submission of an updated Program is WHOLE.
C. Quality Control	
GCC 34.1 <i>[The Defects</i>	The Defects Liability Period is: SIX MONTHS FROM PRACTICAL COMPLETION DATE. <i>Liability Period is usually limited to 12 months, but could be less in very simple cases]</i>
D. Cost Control	
GCC 38.9	If the value engineering proposal is approved by the Procuring Entity the amount to be paid to the Contractor shall be_% <i>(insert appropriate percentage. The percentage is normally up to 50%)</i> of the reduction in the Contract Price. N/A
GCC 44.1	The currency of the Procuring Entity's Country is: <i>[insert name of currency of the Procuring Entity's Country]</i> . KES
GCC 45.1	The Contract " <i>is not</i> " subject to price adjustment in accordance with GCC Clause 45, and the following information regarding coefficients <i>[specify "does" or "does not"]</i> apply. <i>[Price adjustment is mandatory for contracts which provide for time of completion exceeding 18 months]</i> The coefficients for adjustment of prices are: (a) <i>[insert percentage]</i> percent nonadjustable element (coefficient A). (b) <i>[insert percentage]</i> percent adjustable element (coefficient B). (c) The Index I for shall be <i>[insert index]</i> .
GCC 46.1	The proportion of payments retained is: 10% <i>[insert percentage]</i>
GCC 47.1	The liquidated damages for the whole of the Works are 5% per day. The maximum amount of liquidated damages for the whole of the Works is 10% of the final Contract Price.
GCC 48.1	The Bonus for the whole of the Works is <i>[insert percentage of final Contract Price]</i> per day. The maximum amount of Bonus for the whole of the Works is <i>[insert percentage]</i> of the final Contract Price. N/A
Number of GC Clause	Amendments of, and Supplements to, Clauses in the General Conditions of Contract
GCC 49.1	The Advance Payments shall be: <i>[insert amount(s)]</i> and shall be paid to the Contractor not later than <i>[insert date(s)]</i> . SHALL NOT BE APPLICABLE

GCC 50.1	<p>The Performance Security amount is 5% OF CONTRACT SUM <i>[insert amount(s) denominated in the types and proportions of the currencies in which the Contract Price is payable, or in a freely convertible currency acceptable to the Procuring Entity]</i></p> <p>(a) Performance Security – Bank Guarantee: in the amount(s) of <i>[insert related figure(s)]</i> percent of the Accepted Contract Amount and in the same currency(ies) of the Accepted Contract Amount.-NA</p> <p>(b) Performance Security – N/A Performance Bond: in the amount(s) of <i>[insert related figure(s)]</i> percent of the Accepted Contract Amount and in the same currency(ies) of the Accepted Contract Amount.</p>
E. Finishing the Contract	
GCC 56.1	<p>The date by which operating and maintenance manuals are required is <i>[insert date]</i>. The date by which “as built” drawings are required is N/A<i>[insert date]</i>.</p>
GCC 56.2	<p>The amount to be withheld for failing to produce “as built” drawings and/or operating and maintenance manuals by the date required in GCC 58.1 is 0.05% <i>[insert amount in local currency]</i>.</p>
GCC 57.2 (g)	<p>The maximum number of days is: <i>[insert number; consistent with Clause 47.1 on liquidated damages]</i>.</p>
GCC 58.1	<p>The percentage to apply to the value of the work not completed, representing the Procuring Entity’s additional cost for completing the Works, is 20%.</p>

FORM No 1: NOTIFICATION OF INTENTION TO AWARD

This Notification of Intention to Award shall be sent to each Tenderer that submitted a Tender. Send this Notification to the Tenderer's Authorized Representative named in the Tender Information Form on the format below.

FORMAT

1. For the attention of Tenderer's Authorized Representative

- i) Name: *[insert Authorized Representative's name]*
- ii) Address: *[insert Authorized Representative's Address]*
- iii) Telephone: *[insert Authorized Representative's telephone/fax numbers]*
- iv) Email Address: *[insert Authorized Representative's email address]*

[IMPORTANT: insert the date that this Notification is transmitted to Tenderers. The Notification must be sent to all Tenderers simultaneously. This means on the same date and as close to the same time as possible.]

2. Date of transmission: *[email]* on *[date]* (local time)

This Notification is sent by *(Name and designation)* _____

3. Notification of Intention to Award

- i) Procuring Entity: *[insert the name of the Procuring Entity]*
- ii) Project: *[insert name of project]*
- iii) Contract title: *[insert the name of the contract]*
- iv) Country: *[insert country where ITT is issued]*
- v) ITT No: *[insert ITT reference number from Procurement Plan]*

This Notification of Intention to Award (Notification) notifies you of our decision to award the above contract. The transmission of this Notification begins the Standstill Period. During the Standstill Period, you may:

4. Request a debriefing in relation to the evaluation of your tender

Submit a Procurement-related Complaint in relation to the decision to award the contract.

a) The successful tenderer

- i) Name of successful Tender _____
- ii) Address of the successful Tender _____
- iii) Contract price of the successful Tender Kenya Shillings _____ (in words _____)

b) Other Tenderers

Names of all Tenderers that submitted a Tender. If the Tender's price was evaluated include the evaluated price as well as the Tender price as read out. For Tenders not evaluated, give one main reason the Tender was unsuccessful.

SNo	Name of Tender	Tender Price as read out	Tender's evaluated price (Note a)	One Reason Why not Evaluated
1				
2				
3				
4				
5				

(Note a) State NE if not evaluated

5. How to request a debriefing

- a) DEADLINE: The deadline to request a debriefing expires at midnight on *[insert date]* (local time).
- b) You may request a debriefing in relation to the results of the evaluation of your Tender. If you decide to request a debriefing your written request must be made within three (5) Business Days of receipt of this Notification of Intention to Award.
- c) Provide the contract name, reference number, name of the Tenderer, contact details; and address the request for debriefing as follows:
 - i) Attention: *[insert full name of person, if applicable]*
 - ii) Title/position: *[insert title/position]*
 - ii) Agency: *[insert name of Procuring Entity]*
 - iii) Email address: *[insert email address]*
- d) If your request for a debriefing is received within the 3 Days deadline, we will provide the debriefing within five (3) Business Days of receipt of your request. If we are unable to provide the debriefing within this

period, the Standstill Period shall be extended by five (3) Days after the date that the debriefing is provided. If this happens, we will notify you and confirm the date that the extended Standstill Period will end.

- e) The debriefing may be in writing, by phone, video conference call or in person. We shall promptly advise you in writing how the debriefing will take place and confirm the date and time.
- f) If the deadline to request a debriefing has expired, you may still request a debriefing. In this case, we will provide the debriefing as soon as practicable, and normally no later than fifteen (15) Days from the date of publication of the Contract Award Notice.

6. **How to make a complaint**

- a) Period: Procurement-related Complaint challenging the decision to award shall be submitted by midnight, [insert date] (local time).
- b) Provide the contract name, reference number, name of the Tenderer, contact details; and address the Procurement-related Complaint as follows:
 - i) Attention: [insert full name of person, if applicable]
 - ii) Title/position: [insert title/position]
 - iii) Agency: [insert name of Procuring Entity]
 - iv) Email address: [insert email address]
- c) At this point in the procurement process, you may submit a Procurement-related Complaint challenging the decision to award the contract. You do not need to have requested, or received, a debriefing before making this complaint. Your complaint must be submitted within the Standstill Period and received by us before the Standstill Period ends.
- d) Further information: For more information refer to the Public Procurement and Disposals Act 2015 and its Regulations available from the Website info@ppra.go.ke or complaints@ppra.go.ke.
You should read these documents before preparing and submitting your complaint.
- e) There are four essential requirements:
 - i) You must be an 'interested party'. In this case, that means a Tenderer who submitted a Tender in this tendering process, and is the recipient of a Notification of Intention to Award.
 - ii) The complaint can only challenge the decision to award the contract.
 - iii) You must submit the complaint within the period stated above.
 - iv) You must include, in your complaint, all of the information required to support your complaint.

7. **Standstill Period**

- i) DEADLINE: The Standstill Period is due to end at midnight on [insert date] (local time).
- ii) The Standstill Period lasts ten (14) Days after the date of transmission of this Notification of Intention to Award.
- iii) The Standstill Period may be extended as stated in paragraph Section 5 (d) above.

If you have any questions regarding this Notification please do not hesitate to contact us. On behalf of the Procuring Entity:

Signature: _____ **Name:** _____

Title/position: _____ **Telephone:** _____ **Email:** _____

FORM NO. 2 - REQUEST FOR REVIEW

FORM FOR REVIEW(r.203(1))

PUBLIC PROCUREMENT ADMINISTRATIVE REVIEW BOARD

APPLICATION NO.....OF.....20.....

BETWEEN

.....**APPLICANT**

AND

.....**RESPONDENT (Procuring Entity)**

Request for review of the decision of the..... (Name of the Procuring Entity ofdated the...day of20.....in the matter of Tender No.....of20..... for.....(Tender description).

REQUEST FOR REVIEW

I/We.....,the above named Applicant(s), of address: Physical address.....P. O. Box No..... Tel. No.....Email....., hereby request the Public Procurement Administrative Review Board to review the whole/part of the above mentioned decision on the following grounds , namely:

- 1.
- 2.

By this memorandum, the Applicant requests the Board for an order/orders that:

- 1.
- 2.

SIGNED(Applicant) Dated on.....day of/...20.....

FOR OFFICIAL USE ONLY Lodged with the Secretary Public Procurement Administrative Review Board on..... day of20.....

SIGNED

Board Secretary

FORM NO 3: LETTER OF AWARD

[letterhead paper of the Procuring Entity] [date]

To: *[name and address of the Contractor]*

This is to notify you that your Tender dated *[date]* for execution of the *[name of the Contract and identification number, as given in the Contract Data]* for the Accepted Contract Amount *[amount in numbers and words] [name of currency]*, as corrected and modified in accordance with the Instructions to Tenderers, is hereby accepted by.....(*name of Procuring Entity*).

You are requested to furnish the Performance Security within 30 days in accordance with the Conditions of Contract, using, for that purpose, one of the Performance Security Forms included in Section VIII, Contract Forms, of the Tender Document.

Authorized Signature:.....

Name and Title of Signatory:.....

Name of Procuring Entity.....

Attachment: *Contract Agreement*.....

FORM NO 4: CONTRACT AGREEMENT

THIS AGREEMENT made the _____ day of _____, 20____, between _____ of _____ (hereinafter “the Procuring Entity”), of the one part, and _____ of _____ (hereinafter “the Contractor”), of the other part:

WHEREAS the Procuring Entity desires that the Works known as _____ should be executed by the Contractor, and has accepted a Tender by the Contractor for the execution and completion of these Works and the remedying of any defects therein,

The Procuring Entity and the Contractor agree as follows:

1. In this Agreement words and expressions shall have the same meanings as are respectively assigned to them in the Contract documents referred to.
2. The following documents shall be deemed to form and be read and construed as part of this Agreement. This Agreement shall prevail over all other Contract documents.
 - a) the Letter of Acceptance
 - b) the Letter of Tender
 - c) the addenda Nos _____ (if any)
 - d) the Special Conditions of Contract
 - e) the General Conditions of Contract;
 - f) the Specifications
 - g) the Drawings; and
 - h) the completed Schedules and any other documents forming part of the contract.
3. In consideration of the payments to be made by the Procuring Entity to the Contractor as specified in this Agreement, the Contractor hereby covenants with the Procuring Entity to execute the Works and to remedy defects therein in conformity in all respects with the provisions of the Contract.
4. The Procuring Entity hereby covenants to pay the Contractor in consideration of the execution and completion of the Works and the remedying of defects therein, the Contract Price or such other sum as may become payable under the provisions of the Contract at the times and in the manner prescribed by the Contract.

IN WITNESS whereof the parties hereto have caused this Agreement to be executed in accordance with the Laws of Kenya on the day, month and year specified above.

Signed and sealed by _____ (for the Procuring Entity)

Signed and sealed by _____ (for the Contractor).

FORM NO. 5 - PERFORMANCE SECURITY

[Option 1 - Unconditional Demand Bank Guarantee]

[Guarantor letterhead]

Beneficiary: _____ *[insert name and Address of Procuring Entity]* **Date:** _____

_____ *[Insert date of issue]*

Guarantor: *[Insert name and address of place of issue, unless indicated in the letterhead]*

1. We have been informed that _____ (hereinafter called "the Contractor") has entered into Contract No. _____ dated _____ with (name of Procuring Entity) _____ (the Procuring Entity as the Beneficiary), for the execution of _____ (hereinafter called "the Contract").
2. Furthermore, we understand that, according to the conditions of the Contract, a performance guarantee is required.
3. At the request of the Contractor, we as Guarantor, hereby irrevocably undertake to pay the Beneficiary any sum or sums not exceeding in total an amount of _____ (in words),¹ such sum being payable in the types and proportions of currencies in which the Contract Price is payable, upon receipt by us of the Beneficiary's complying demand supported by the Beneficiary's statement, whether in the demand itself or in a separate signed document accompanying or identifying the demand, stating that the Applicant is in breach of its obligation(s) under the Contract, without the Beneficiary needing to prove or to show grounds for your demand or the sum specified therein.
4. This guarantee shall expire, no later than the Day of, 2.....², and any demand for payment under it must be received by us at the office indicated above on or before that date.
5. The Guarantor agrees to a one-time extension of this guarantee for a period notto exceed *[six months]* *[oneyear]*, in response to the Beneficiary's written request for such extension, such request to be presented to the Guarantor before the expiry of the guarantee.”

[Name of Authorized Official, signature(s) and seals/stamps].

Note: *All italicized text (including footnotes) is for use in preparing this form and shall be deleted from the final product.*

¹The Guarantor shall insert an amount representing the percentage of the Accepted Contract Amount specified in the Letter of Acceptance, less provisional sums, if any, and denominated either in the currency of the Contract or a freely convertible currency acceptable to the Beneficiary.

²Insert the date twenty-eight days after the expected completion date as described in GC Clause 11.9. The Procuring Entity should note that in the event of an extension of this date for completion of the Contract, the Procuring Entity would need to request an extension of this guarantee from the Guarantor. Such request must be in writing and must be made prior to the expiration date established in the guarantee.

FORM No. 6 - PERFORMANCE SECURITY

[Option 2– Performance Bond]

[Note: Procuring Entities are advised to use Performance Security – Unconditional Demand Bank Guarantee instead of Performance Bond due to difficulties involved in calling Bondholder to action]

[Guarantor letterhead or SWIFT identifier code]

Beneficiary: _____ *[insert name and Address of Procuring Entity]* **Date:** _____
_____ *[Insert date of issue]*.

PERFORMANCE BOND No.: _____

Guarantor: *[Insert name and address of place of issue, unless indicated in the letterhead]*

1. By this Bond _____ as Principal (hereinafter called “the Contractor”) and _____] as Surety (hereinafter called “the Surety”), are held and firmly bound unto _____] as Obligee (hereinafter called “the Procuring Entity”) in the amount of _____ for the payment of which sum well and truly to be made in the types and proportions of currencies in which the Contract Price is payable, the Contractor and the Surety bind themselves, their heirs, executors, administrators, successors and assigns, jointly and severally, firmly by these presents.
2. WHEREAS the Contractor has entered into a written Agreement with the Procuring Entity dated the _____ day of _____, 20, for _____ in accordance with the documents, plans, specifications, and amendments thereto, which to the extent herein provided for, are by reference made part hereof and are hereinafter referred to as the Contract.
3. NOW, THEREFORE, the Condition of this Obligation is such that, if the Contractor shall promptly and faithfully perform the said Contract (including any amendments thereto), then this obligation shall be null and void; otherwise, it shall remain in full force and effect. Whenever the Contractor shall be, and declared by the Procuring Entity to be, in default under the Contract, the Procuring Entity having performed the Procuring Entity's obligations thereunder, the Surety may promptly remedy the default, or shall promptly:
 - 1) complete the Contract in accordance with its terms and conditions; or
 - 2) obtain a tender or tenders from qualified tenderers for submission to the Procuring Entity for completing the Contract in accordance with its terms and conditions, and upon determination by the Procuring Entity and the Surety of the lowest responsive Tenderers, arrange for a Contract between such Tenderer, and Procuring Entity and make available as work progresses (even though there should be a default or a succession of defaults under the Contract or Contracts of completion arranged under this paragraph) sufficient funds to pay the cost of completion less the Balance of the Contract Price; but not exceeding, including other costs and damages for which the Surety may be liable hereunder, the amount set forth in the first paragraph hereof. The term “Balance of the Contract Price,” as used in this paragraph, shall mean the total amount payable by Procuring Entity to Contractor under the Contract, less the amount properly paid by Procuring Entity to Contractor; or
 - 3) pay the Procuring Entity the amount required by Procuring Entity to complete the Contract in accordance with its terms and conditions up to a total not exceeding the amount of this Bond.
4. The Surety shall not be liable for a greater sum than the specified penalty of this Bond.
5. Any suit under this Bond must be instituted before the expiration of one year from the date of the issuing of the Taking-Over Certificate. No right of action shall accrue on this Bond to or for the use of any person or corporation other than the Procuring Entity named herein or the heirs, executors, administrators, successors, and assigns of the Procuring Entity.
6. In testimony whereof, the Contractor has hereunto set his hand and affixed his seal, and the Surety has caused these presents to be sealed with his corporate seal duly attested by the signature of his legal representative, this day _____ of _____ 20_____.

SIGNED ON _____ on behalf of By ___ in the capacity of In the presence of

SIGNED ON _____ on behalf of By ___ in the capacity of In the presence of

FORM NO. 7 - ADVANCE PAYMENT SECURITY

[Demand Bank Guarantee]

[Guarantor letterhead]

Beneficiary: _____ *[Insert name and Address of Procuring Entity]*

Date: _____ *[Insert date of issue]*

ADVANCE PAYMENT GUARANTEE No.: _____ *[Insert guarantee reference number]* **Guarantor:** _____
_____ *[Insert name and address of place of issue, unless indicated in the letterhead]*

1. We have been informed that _____ (hereinafter called "the Contractor") has entered into Contract No. _____ dated _____ with the Beneficiary, for the execution of _____ (hereinafter called "the Contract").
2. Furthermore, we understand that, according to the conditions of the Contract, an advance payment in the sum _____ (in words) is to be made against an advance payment guarantee.
3. At the request of the Contractor, we as Guarantor, hereby irrevocably undertake to pay the Beneficiary any sum or sums not exceeding in total an amount of _____ (in words _____)¹ upon receipt by us of the Beneficiary's complying demand supported by the Beneficiary's statement, whether in the demand itself or in a separate signed document accompanying or identifying the demand, stating either that the Applicant:
 - a) has used the advance payment for purposes other than the costs of mobilization in respect of the Works; or
 - b) has failed to repay the advance payment in accordance with the Contract conditions, specifying the amount which the Applicant has failed to repay.
4. A demand under this guarantee may be presented as from the presentation to the Guarantor of a certificate from the Beneficiary's bank stating that the advance payment referred to above has been credited to the Contractor on its account number _____ at _____.
5. The maximum amount of this guarantee shall be progressively reduced by the amount of the advance payment repaid by the Contractor as specified in copies of interim statements or payment certificates which shall be presented to us. This guarantee shall expire, at the latest, upon our receipt of a copy of the interim payment certificate indicating that ninety (90) percent of the Accepted Contract Amount, less provisional sums, has been certified for payment, or on the ___ day of _____, 2², whichever is earlier. Consequently, any demand for payment under this guarantee must be received by us at this office on or before that date.
6. The Guarantor agrees to a one-time extension of this guarantee for a period not to exceed *[six months]* *[one year]*, in response to the Beneficiary's written request for extension, such request to be presented to the Guarantor before the expiry of the guarantee.

[Name of Authorized Official, signature(s) and seals/stamps]

Note: All italicized text (including footnotes) is for use in preparing this form and shall be deleted from the final product.

¹The Guarantor shall insert an amount representing the amount of the advance payment and denominated either in the currency of the advance payment as specified in the Contract.

²Insert the expected expiration date of the Time for Completion. The Procuring Entity should note that in the event of an extension of the time for completion of the Contract, the Procuring Entity would need to request an extension of this guarantee from the Guarantor. Such request must be in writing and must be made prior to the expiration date established in the guarantee.

FORM NO. 8 - RETENTION MONEY SECURITY

[Demand Bank Guarantee]

[Guarantor letterhead]

Beneficiary: _____ *[Insert name and Address of Procuring Entity]*

Date: _____ *[Insert date of issue]*

Advance payment guarantee no. *[Insert guarantee reference number]*

Guarantor: *[Insert name and address of place of issue, unless indicated in the letterhead]*

1. We have been informed that _____ *[insert name of Contractor, which in the case of a joint venture shall be the name of the joint venture]* (hereinafter called "the Contractor") has entered into Contract No. _____ *[insert reference number of the contract]* dated _____ with the Beneficiary, for the execution of _____ *[insert name of contract and brief description of Works]* (hereinafter called "the Contract").
2. Furthermore, we understand that, according to the conditions of the Contract, the Beneficiary retains moneys up to the limit set forth in the Contract ("the Retention Money"), and that when the Taking-Over Certificate has been issued under the Contract and the first half of the Retention Money has been certified for payment, and payment of *[insert the second half of the Retention Money]* is to be made against a Retention Money guarantee.
3. At the request of the Contractor, we, as Guarantor, hereby irrevocably undertake to pay the Beneficiary any sum or sums not exceeding in total an amount of *[insert amount in figures]* _____ *([insert amount in words _____])*¹ upon receipt by us of the Beneficiary's complying demand supported by the Beneficiary's statement, whether in the demand itself or in a separate signed document accompanying or identifying the demand, stating that the Contractor is in breach of its obligation(s) under the Contract, without your needing to prove or show grounds for your demand or the sum specified therein.
4. A demand under this guarantee may be presented as from the presentation to the Guarantor of a certificate from the Beneficiary's bank stating that the second half of the Retention Money as referred to above has been credited to the Contractor on its account number _____ at _____ *[insert name and address of Applicant's bank]*.
5. This guarantee shall expire no later than the Day of, 2.....², and any demand for payment under it must be received by us at the office indicated above on or before that date.
6. The Guarantor agrees to a one-time extension of this guarantee for a period not to exceed *[six months]* *[one year]*, in response to the Beneficiary's written request for such extension, such request to be presented to the Guarantor before the expiry of the guarantee.

[Name of Authorized Official, signature(s) and seals/stamps]

Note: All italicized text (including footnotes) is for use in preparing this form and shall be deleted from the final product.

¹The Guarantor shall insert an amount representing the amount of the second half of the Retention Money.

²Insert a date that is twenty-eight days after the expiry of retention period after the actual completion date of the contract. The Procuring Entity should note that in the event of an extension of this date for completion of the Contract, the Procuring Entity would need to request an extension of this guarantee from the Guarantor. Such request must be in writing and must be made prior to the expiration date established in the guarantee.

FORM NO. 9 BENEFICIAL OWNERSHIP DISCLOSURE FORM

(Amended and issued pursuant to PPRA CIRCULAR No. 02/2022)

INSTRUCTIONS TO TENDERERS: DELETE THIS BOX ONCE YOU HAVE COMPLETED THE FORM

This Beneficial Ownership Disclosure Form (“Form”) is to be completed by the successful tenderer pursuant to Regulation 13 (2A) and 13 (6) of the Companies (Beneficial Ownership Information) Regulations, 2020. In case of joint venture, the tenderer must submit a separate Form for each member. The beneficial ownership information to be submitted in this Form shall be current as of the date of its submission.

For the purposes of this Form, a Beneficial Owner of a Tenderer is any natural person who ultimately owns or controls the legal person (tenderer) or arrangements or a natural person on whose behalf a transaction is conducted, and includes those persons who exercise ultimate effective control over a legal person (Tenderer) or arrangement.

Tender Reference No.: _____ [insert identification no]

Name of the Tender Title/Description: _____ [insert name of the assignment] to:
 _____ [insert complete name of Procuring Entity]

In response to the requirement in your notification of award dated _____ [insert date of notification of award] to furnish additional information on beneficial ownership: _____ [select one option as applicable and delete the options that are not applicable]

I) We here by provide the following beneficial ownership information.

Details of beneficial ownership

	Details of all Beneficial Owners		% of shares a person holds in the company Directly or indirectly	% of voting rights a person holds in the company	Whether a person directly or indirectly holds a right to appoint or remove a member of the board of directors of the company or an equivalent governing body of the Tenderer (Yes / No)	Whether a person directly or indirectly exercises significant influence or control over the Company (tenderer) (Yes / No)
1.	Full Name		Directly----- ----- % of shares	Directly.....% of voting rights	1. Having the right to appoint a majority of the board of the directors or an equivalent governing body of the Tenderer: Yes ----No---- 2. Is this right held directly or indirectly?: Direct..... ... Indirect.....	1. Exercises significant influence or control over the Company body of the Company (tenderer) Yes ----No---- 2. Is this influence or control exercised directly or indirectly? Direct..... Indirect.....
	National identity card number or Passport number					
	Personal Identification Number (where applicable)		Indirectly--- -----% of shares	Indirectly----- % of voting rights		
	Nationality					
	Date of birth [dd/mm/yyyy]					
	Postal address					
	Residential address					
	Telephone number					
	Email address					
Occupation or profession						
2.	Full Name		Directly-----	Directly.....		

Details of all Beneficial Owners		% of shares a person holds in the company Directly or indirectly	% of voting rights a person holds in the company	Whether a person directly or indirectly holds a right to appoint or remove a member of the board of directors of the company or an equivalent governing body of the Tenderer (Yes / No)	Whether a person directly or indirectly exercises significant influence or control over the Company (tenderer) (Yes / No)
National identity card number or Passport number		---- % of shares% of voting rights	1. Having the right to appoint a majority of the board of the directors or an equivalent governing body of the Tenderer: Yes ----No---- 2. Is this right held directly or indirectly?: Direct..... ... Indirect.....	1. Exercises significant influence or control over the Company body of the Company (tenderer) Yes ----No---- 2. Is this influence or control exercised directly or indirectly? Direct..... Indirect.....
Personal Identification Number (where applicable)		Indirectly---- % of shares	Indirectly----- % of voting rights		
Nationality(ies)					
Date of birth [dd/mm/yyyy]					
Postal address					
Residential address					
Telephone number					
Email address					
Occupation or profession					
3.					
e.t					
.c					

II) Am fully aware that beneficial ownership information above shall be reported to the Public Procurement Regulatory Authority together with other details in relation to contract awards and shall be maintained in the Government Portal, published and made publicly available pursuant to Regulation 13(5) of the Companies (Beneficial Ownership Information) Regulations, 2020. (Notwithstanding this paragraph Personally Identifiable Information in line with the Data Protection Act shall not be published or made public). *Note that Personally Identifiable Information (PII) is defined as any information that can be used to distinguish one person from another and can be used to deanonymize previously anonymous data. This information includes National identity card number or Passport number, Personal Identification Number, Date of birth, Residential address, email address and Telephone number.*

III) In determining who meets the threshold of who a beneficial owner is, the Tenderer must consider a natural person who in relation to the company:

- (a) holds at least ten percent of the issued shares in the company either directly or indirectly;
- (b) exercises at least ten percent of the voting rights in the company either directly or indirectly;
- (c) holds a right, directly or indirectly, to appoint or remove a director of the company; or
- (d) exercises significant influence or control, directly or indirectly, over the company.

IV) What is stated to herein above is true to the best of my knowledge, information and belief.

Name of the Tenderer.....*[insert complete name of the Tenderer]_____

Name of the person duly authorized to sign the Tender on behalf of the Tenderer: ** [insert complete name of person duly authorized to sign the Tender]

Designation of the person signing the Tender..... [insert complete title of the person signing the Tender]

Signature of the person named above..... [insert signature of person whose name and capacity are shown above]

Date this [insert date of signing] day of..... [Insert month], [insert year]

Bidder Official Stamp

BILL OF QUANTITIES

REPUBLIC OF KENYA



DEPARTMENT OF TRANSPORT, INFRASTRUCTURE AND PUBLIC WORKS

DIRECTORATE OF PUBLIC WORKS

BILLS OF QUANTITIES

FOR:

PROPOSED CONSTRUCTION OF A ONE STOREYED TUITION BLOCK AT

KOMBE DAY SENIOR SCHOOL -

NANDI COUNTY

JUNE, 2026

ITEM	DESCRIPTION	AMOUNT
A	<p><u>BILL NO. 1</u></p> <p><u>PARTICULAR PRELIMINARIES</u></p> <p><u>PARTIES</u></p> <p>The Employer is:</p> <p>NATIONAL GOVERNMENT - CONSTITUENCY DEVELOPMENT FUND (CDF) CHESUMEI CONSTITUENCY - SUBCOUNTY P.O Box 40 -30300 KAPSABET, KENYA</p> <p>The Engineer is: The term "PM" wherever used in these Bills of Quantities shall be deemed to imply the Engineer as defined in Condition 1 of the Conditions of Contract or such person or persons as may be duly authorised to represent him on behalf of the Government .</p> <p>The Architect is: State Department For Public Works P.O Box 87 -30300 KAPSABET, KENYA</p> <p>The Quantity Surveyors is: State Department For Public Works P.O Box 87 -30300 KAPSABET, KENYA</p> <p>The Structural/ Civil Engineers is: State Department For Public Works P.O Box 87 -30300 KAPSABET, KENYA</p> <p>The Electrical / Mechanical Engineers is: State Department For Public Works P.O Box 87 -30300 KAPSABET, KENYA</p>	

ITEM	DESCRIPTION	AMOUNT
<p>A</p>	<p><u>LOCATION OF SITE</u></p> <p>The site of the proposed works is located in Kombe, Nandi County</p> <p>The Contractor shall be deemed to have visited the site and satisfied himself as to:-</p> <p>a) The nature, position, topography and access of the site b) The amount of the rubbish or debris to be cleared away before commencement. c) The nature, current usage, proximity and size of adjoining property and buildings d) The availability of land for the erection and positioning of all temporary structures, plant and materials necessary for the execution of the works.</p> <p>The Contractor shall obtain approval from the relevant Local Authority in adherence to site access and erection of temporary structures and must ensure all matters relating to the requirements of these authorities.</p> <p>No claim will be allowed for travelling or other expenses which may be incurred by the Contractor in visiting the site or preparing the tender for the works.</p>	
<p>B</p>	<p><u>EXISTING SITE CONDITIONS</u></p> <p>The Contractor is advised that the site is in a predominantly residential area and all measures should be taken to avoid nuisance to neighbours.</p> <p>All occupation health and safety requirements must be met as required by law.</p> <p>This includes prevention and or minimizing noise, dust, fumes e.t.c.</p> <p>Notices should be given prior to disruption of services</p>	
<p>C</p>	<p><u>SCOPE OF CONTRACT</u></p> <p>The Works under this contract comprises of the structures as detailed in the project data sheet</p>	
	<p>Carried to collection</p>	

ITEM	DESCRIPTION	AMOUNT
<p>A</p>	<p><u>DESCRIPTION OF THE WORKS</u></p> <p>The construction comprises reinforced concrete foundations, masonry walling, reinforced concrete beams, column , staircases and suspended solid slabs, roof construction.</p> <p>The exterior facade consists of steel casement windows, steel and timber doors , render and paint finish, clay and stone facing finish to walls</p> <p>The interior works includes timber doors and finishes which are generally plaster and paint to walls, ceramic and non slip ceramic tiles to floors and walls.</p> <p>External works generally comprise of driveways, parking areas, foul water drainage, storm water drainage, footpaths, retaining walls, boundary wall and gates.</p> <p>All mechanical / electrical services and other specialist works associated with the above works shall be executed by domestic/nominated sub contractors approved by the Engineer</p> <p><u>CONTRACT PARTICULARS</u></p> <p>B</p> <p><u>FORM OF CONTRACT</u></p> <p>The Contractor will be required to enter into a contract with the Employer under the Terms and Conditions of Contract as "Standard Tender Document for Procurement of Works (Building and Associated Civil Engineering Works) Issued by the Public Procurement Regulatory Authority in February 2021 (updated 2022) and in association with the latest applicable version of the Public Procurement and Asset Disposal Act.</p> <p>The Contractor's attention is called to the appendix of the conditions of Contract and additions and amendments thereto, which shall be read as incorporated herein and he shall allow any sums which he considers necessary for the observance of such conditions, together with sub clauses used in application.</p> <p>The priority of such documents shall be as stated in the conditions of agreement.</p>	
	<p>Carried to collection</p>	

ITEM	DESCRIPTION	AMOUNT
A	<p><u>LIABILITY AGAINST INJURY TO PERSONS AND PROPERTY</u></p> <p>Insurance against injury to persons and property</p> <p>NOTES In addition to the conditions of the contract and the requirement contained herein the contractor's all risk policy shall cover the full value of the following and allow for all costs thereof:-</p> <ul style="list-style-type: none"> i) The works and temporary works erected in performance of this contract. ii) The materials on site, plant and tools iii) The cost and expense of removing debris of the property insured, destroyed or damaged by any peril insured. iv) Professional fees (to be allowed at 15% of the contract sum) v) Employer's liability (workman's compensation) ii) Third party (Public liability for an indemnity of not less than shs 15,000,000 for any accident or series of accidents arising from the same event (unlimited in aggregate) <p>The contractor shall ensure that all sub-contractors effect and maintain such insurances as are necessary to cover their liabilities in respect of injury to persons and property and workman,s compensation.</p> <p>Should the contractor already hold annual insurances covering the whole of his activities, and the indemnity required under the existing policy/ies then further insurances shall be effected and maintained to cover such excess, the policies of insurances being suitably endorsed to cover this project</p>	
B	<p><u>Insurance of the works (contractors liability)</u></p> <p>The Contractor shall insure as required in the Conditions of Contract. No payment on account of the work executed will be made to the Contractor until he has satisfied the Engineer either by production of an Insurance Policy or and Insurance Certificate that the provision of the foregoing Insurance Clauses have been complied with in all respects.</p> <p>Thereafter the Engineer shall from time to time ascertain that premiums are duly paid up by the Contractor who shall if called upon to do so, produce the receipted premium renewals for the Engineer's inspection.</p>	
	<p>Carried to collection</p>	

ITEM	DESCRIPTION	AMOUNT
A	<p><u>PERFORMANCE BOND</u></p> <p><u>PERFORMANCE BOND</u></p> <p>The Contractor shall submit on the Form of Tender an approved bank or approved (By PPRA) Insurance Company and who will be willing to be bound to the Employer in an amount(as defined in the bidding documents)..... for the due performances of the Contract up to the date of completion as certified by the Engineer and who will when and if called upon, sign a Bond to that effect on the relevant standard form as seen in the CONTRACT STANDARD FORMS (without the addition of any limitations)</p> <p>And should the surety fail to be approved, the Contractor shall furnish within seven days another Surety to the approval of the Employer.</p> <p>Note that no payments on account of works executed will be made to the Contractor until he has submitted the Performance bond, duly stamped signed and sealed by an approved bank or insurance company.</p>	
B	<p><u>POSSESSION AND COMMENCEMENT</u></p> <p>The Contractor shall take possession of the site on the date indicated in the acceptance letter. The date of commencement of the works shall also be communicated to the Contractor and the contract period shall run from the commencement date.</p> <p>The Contractor is expected to utilize the period between possession and commencement to mobilise his resources to ensure smooth running of the works from the commencement date.</p>	
	Carried to collection	

ITEM	DESCRIPTION	AMOUNT
A	<p><u>PROJECT SUPERVISION</u></p> <p>The said works shall be executed under the direction and to the entire satisfaction of the Engineer and Clerk of works who shall have the Engineer's specifically delegated authority and shall at all times have access to the works, to the yards and workshops of the contractor or other places where goods are being prepared for the building.</p>	
B	<p><u>LABOUR CAMPS</u></p> <p>The contractor will generally be permitted to house labour on site subject to approval by Architect</p>	
C	<p><u>DOWNTAKINGS</u></p> <p>All materials arising from demolitions and dountakings are deemed to be the property of the employer. No claim will be entertained on account of employer excising this right to retain the materials</p>	
	<p>All dountakings shall be carefully removed, taken down, dismantled and stored on site until instructed by the Engineer to remove from the site. Such materials shall only be incorporated in the new works if required by the Engineer in which case appropriate adjustments will be made in the final account for the cost of labour, screws etc for fixing such dountakings in the new works.</p>	
D	<p><u>DAMAGES</u></p> <p>Damages for delay in completion shall be levied at the rate of Kshs(Refer to the special Conditions of Contract).....</p>	
E	<p><u>OTHER PRELIMINARIES</u></p> <p>Allow for any other item necessary to execute the works and state them below;</p> <p>.....</p> <p>.....</p> <p>.....</p> <p>.....</p>	
	<p>Carried to collection</p>	

ITEM	DESCRIPTION	AMOUNT
	<p><u>BILL NO. 1</u></p> <p><u>PARTICULAR PRELIMINARIES</u></p> <p><u>COLLECTION</u></p> <p>Carried from page 1/1</p> <p>Carried from page 1/2</p> <p>Carried from page 1/3</p> <p>Carried from page 1/4</p> <p>Carried from page 1/5</p> <p>Carried from page 1/6</p>	
	<p>Particular Preliminaries Carried to Summary of Bill No. 1</p>	

ITEM	DESCRIPTION	AMOUNT
	<p><u>BILL NO. 2</u></p> <p><u>GENERAL PRELIMINARIES</u></p> <p><u>PRICING OF ITEMS OF PRELIMINARIES AND PREAMBLES</u></p> <p>A Whenever in the Contractor's priced Bills of Quantities no price appears against an item of Preliminaries or Preambles or work items , the value of such item shall be deemed to be included in his prices for other items in the Bills of Quantities.</p> <p><u>SUFFICIENCY OF TENDER</u></p> <p>B The Contractor shall be deemed to have satisfied himself before tendering as to the correctness and sufficiency of his tender for the works and of the rates and prices stated in the priced Bills of Quantities. Rates and prices quoted shall cover all his obligations under the contract and all the matters and maintenance of the works</p> <p><u>RECORDS</u></p> <p>C The Contractor shall ensure proper records are kept and maintained for : Daily Reports on Personnel and Machinery; tracked programme; weather charts/reports; site instruction book and query book,a digital camera shall be provided for taking progress photos</p> <p>The contractor shall be required to provide equipment for taking ground and aerial photos or videos in relation to the progress of works when called upon to do so.</p> <p><u>DEFINITIONS AND ABBREVIATIONS</u></p> <p>D Throughout these Bills, units of measurements and terms are abbreviated and shall be interpreted as follows:</p> <p>mm shall mean millimeter</p> <p>lm shall mean linear meter</p> <p>sm shall mean square meter</p> <p>m² shall mean square meter</p> <p>cm shall mean cubic meter</p> <p>kg shall mean kilogramme</p> <p>N shall mean Newton</p> <p>KN shall mean KiloNewton</p> <p>Carried to collection</p>	

ITEM	DESCRIPTION	AMOUNT
	<p>in/" shall mean inches</p> <p>L f shall mean linear foot</p> <p>s f shall mean square foot</p> <p>c f shall mean cubic foot</p> <p>L b shall mean pound avoirdupois</p> <p>No. shall mean number</p> <p>B.S.M shall mean both sides measured</p> <p>K.S. shall mean current Kenya Standard specification published by the Kenya Bureau of Standard, P.O. Box 54974. NAIROBI, Kenya.</p> <p>'As described' shall mean as described in these Bills of Quantities.</p> <p>'As before described' shall mean the whole of the previous description except as qualified in the current one.</p>	
	<p>Carried to collection</p>	

ITEM	DESCRIPTION	AMOUNT
<p data-bbox="175 279 196 300">A</p>	<p data-bbox="240 218 391 239"><u>SITE LEVELS</u></p> <p data-bbox="240 279 1170 331">Before commencing work the Contractor must arrange for and agree with the Architect, Engineer and Quantity Surveyor the existing site levels and similarly establish and agree on a bench mark.</p> <p data-bbox="240 384 1170 436">The Contractor shall provide a surveyor to ensure all levels are achieved as per the drawings and Architects/Structural Engineer's instructions</p> <p data-bbox="240 474 399 495"><u>SETTING OUT</u></p> <p data-bbox="240 531 1170 699">The contractor shall set out works in accordance with the dimensions and levels shown on the drawings and shall be responsible for the correctness of all dimensions and levels set out by him and he will be required to amend all errors arising from inaccurate setting out at his own cost and expenses. In the event of any error or discrepancy in the dimensions or levels marked on the drawings being discovered, such errors or discrepancies must be reported by the Contractor to the Engineer for his immediate attention.</p> <p data-bbox="240 741 1170 877">No work shall be commenced by the Contractor until he has received written instructions from the Engineer to adjust such discrepancies which may be proved, upon receipt of such instructions and no claim for extra expenses or relief from the provisions of Clause 5 of the Conditions of the Contract , any discrepancy or error in the dimensions or levels shown on the drawings may be made thereafter.</p> <p data-bbox="240 919 1170 1056">The Contractor shall give the Engineer reasonable notice of the intention to set out or take levels for any part of the Works so that arrangements may be made for checking the work. The accuracy of setting out and leveling shall be within the tolerances specified in the Specifications or on the Drawings. The checking of setting out or leveling by the Engineer shall not relieve the Contractor of his duties or responsibilities under the Contract.</p> <p data-bbox="240 1098 440 1119"><u>MEASUREMENTS</u></p> <p data-bbox="175 1161 196 1182">C</p> <p data-bbox="240 1161 1170 1213">Measurements are based on Standard Methods of Measurement of Building Works and Associated Civil Works For Eastern Africa (SMM) Second Edition 2008.</p> <p data-bbox="240 1245 1170 1297">In the event of any discrepancies arising between the Bills of Quantities and the actual works, the site measurements shall generally take precedence.</p> <p data-bbox="175 1360 196 1381">D</p> <p data-bbox="240 1360 561 1381"><u>GENERAL SPECIFICATIONS</u></p> <p data-bbox="240 1423 1170 1476">All works to be carried out in accordance with the Ministry of Roads, public Works and Housing General Specifications for Building Works issued in 1976 or as qualified and amended.</p>	
	<p data-bbox="240 1570 443 1591">Carried to collection</p>	

ITEM	DESCRIPTION	AMOUNT
A	<p><u>SAMPLES</u></p> <p>The contractor shall furnish at the earliest possible opportunity before work commences and at his own cost any samples of materials or workmanship that may be called for by the Engineer for his approval or rejection until such samples are approved to be the acceptable standard for the work to which they apply.</p> <p>The samples shall be maintained and displayed on a designated section within the site for the duration of the project where practical and possible.</p>	
B	<p><u>PROTECTION OF EXISTING PROPERTY</u></p> <p>The contractor shall take every precaution to avoid damage to all existing property including boundary wall, carpark, roads, cables, drains, staircases, lift etc including other services and he will be held responsible for all damages hereto arising from the execution of his contract and he shall make good all such damages when directed at his own expense.</p> <p>Any damage or disturbances caused to any element shall be reported immediately to the Engineer and the relevant Authority and shall be made good to their satisfaction at the Contractor's expense.</p>	
C	<p><u>PROTECTION / RELOCATION OF EXISTING SERVICES</u></p> <p>Prior to commencement of any work the Contractor is to ascertain from the relevant Authorities the exact position, depth and level of all existing electric cables, water pipes and all other services in the area and he shall make whatever provisions may be required by the authorities concerned for the support and protection and/or relocation of such services as will be necessitated.</p> <p>The contractor is also expected to generate a utility management plan to the approval of the Engineer .</p> <p>Any damage or disturbances caused to any service shall be reported immediately to the Engineer and the relevant Authority and shall be made good to their satisfaction at the Contractor's expense.</p>	
	<p>Carried to collection</p>	

ITEM	DESCRIPTION	AMOUNT
A	<p><u>MATERIALS, TOOLS, PLANT AND SCAFFOLDINGS</u></p> <p>All materials and workmanship used in the execution of the works shall be of the best quality and description. Any materials for the works condemned by the Engineer shall immediately be removed from the site at the Contractor's expense.</p> <p>The Contractor shall be responsible for the provision of all materials, scaffolding, tools, plant, transport and workmen required for the works except in so far as may be stated otherwise herein and he shall allow for the provision of the foregoing except for such items specifically and only required for the use of Nominated Sub-contractors as described herein.</p> <p>No timber used for scaffolding, formwork or similar purpose shall be used afterwards in the permanent works.</p> <p>All such plant, tools and scaffolding shall comply with all regulations whether general or local in force including Environmental, Social, Health and Safety (ESHS) policies throughout the period of the contract and shall be required as may be necessary to comply with any amendments in or additions to such regulations</p> <p>The Contractor shall keep on the site and maintain in good condition one dumpy or quickset level, metric leveling staff and one 30 metre steel tape for the use of the Architect, Surveyor and Engineer.</p> <p>The contractor may be required to provide an appropriate tower crane as required during the project life. Where a crane is provided, it should meet all regulatory and technical standards, all licences in connection with erection, usage shall be at the Contractors expense.</p> <p>The contractor may be required to provide an appropriate tower crane as required during the project life. Where a crane is provided, it should meet all regulatory and technical standards, all licences in connection with erection, usage shall be at the contractors expense.</p>	
	<p>Carried to collection</p>	

ITEM	DESCRIPTION	AMOUNT
<p>A</p>	<p><u>LOCAL REGULATIONS AND BY-LAWS</u></p> <p>The contractor is to comply with all local regulations and by-laws of the Local Authority including serving notices and paying of fees where applicable. These include, but not limited to: National Environmental Management Authority (NEMA), National Construction Authority (NCA), Water Resources Authority (WRA)</p> <p>The Contractor will be held responsible for serving on the Chief Inspector of Factories a written notice not later than seven days after the beginning of the building operations included in this contract stating the particulars required.</p> <p><u>TRANSPORT TO AND FROM THE SITE</u></p> <p>B</p> <p>The Contractor shall include in his prices for the transport of materials, workmen etc to and from the site of the proposed works at such hours and by such routes as are permitted by the Authorities.</p> <p>All unit rates for local or imported goods are to include freight, insurance, handling and delivery costs to the project site together with import duties, sale tax, port charges etc and all other charges of whatever nature.</p>	
	<p>Carried to collection</p>	

ITEM	DESCRIPTION	AMOUNT
<p>A</p>	<p><u>FAIR WAGES</u></p> <p>The Contractor shall pay rates of wages and observe hours and conditions of labour not less favourable than the minimum conditions of employment applicable in the area in which the work is carried out. The relevant notice must be posted up and kept posted upon the site where it can be conveniently read by the employees concerned in languages they can understand.</p> <p>The Contractor is to comply with the regulations of Wages and Conditions of Employment Act, Building and Construction Industry Wages Council and is to be responsible for compliance of the sub-contractors employed in the execution of the contract. If required he is to notify the Engineer of the names and addresses of all such Sub-contractors. Any Contractor or Sub-contractors not complying will not be permitted to tender for other work for such a period as the Engineer may determine</p> <p>Should a claim be made to the Engineer alleging the Contractor's default in payment of fair wages to any workman employed on the contract and if proof thereof satisfactory to the Engineer, may failing payment by the Contractor, pay the claim out of any monies due or which may become due to the contractor under this contract.</p> <p>The Contractor is to furnish to the Engineer, if called upon to do so, such particulars of the rates of wages, hours and conditions of labour referred to above as the Engineer may direct</p>	
	<p>B</p> <p><u>SECURITY OF WORKS</u></p> <p>The Contractor shall be entirely responsible and shall pay security of all works, stores, materials, plant, personnel etc both his own and sub-contractors and shall also provide all necessary watching, lighting, and other precautions as necessary to ensure the security, the safety and protection of the public. He is to ensure that there is no informal business settlement near the establishment.</p>	
	<p>Carried to collection</p>	

ITEM	DESCRIPTION	AMOUNT
A	<p><u>OCCUPATIONAL HEALTH AND SAFETY MEASURES</u></p> <p>The Engineer expects the Contractor to adhere to strict safety measures. In this regard the Contractor should ensure that all his workers, the Consultants and his sub-Contractors workmen are wearing Personal Protective Equipment (PPE) before commencement of any work where applicable including overalls with the company name clearly printed on the back each with clearly marked Identification Numbers stitched or imprinted on.</p> <p>The Contractor shall allow for providing all watching, lighting, green netting, barriers, signs, covering open trenches and protection of the works, including Sub-Contract works, as may be necessary for the safety of the works and for the protection of the public and his own and Sub-Contractors' employees.</p> <p>He shall also ensure provision of a certified and qualified safety, health and environmental officer, access to ambulance services at all worksites and arrangement to access a local hospital/dispensary with qualified medical staff.</p> <p>The contractor shall take cognisance and shall fully adhere to the regulations of the Occupational Safety and Health Act of 2007 including all the associated revisions</p> <p>The Engineer shall expect full compliance to this regulation and no excuses will be entertained for non-compliance which may lead to suspension of works until the issue is addressed satisfactorily.</p>	
B	<p><u>PUBLIC, PRIVATE ROADS AND PAVEMENTS ETC</u></p> <p>The contractor will be required to make good at his own expense any damages he may cause to the present approach and surrounding road surfaces during the period of the works</p>	
C	<p><u>POLICE REGULATIONS</u></p> <p>The contractor is to allow for complying with all Government Acts, orders or regulations in connection with employment of labour and other matters related to the execution of the works.</p> <p>The Contractor must acquit himself duly with current acts and regulations, including police regulations regarding the movement, housing, security and control of labour, labour camps, passes for transport, etc..</p>	
	<p>Carried to collection</p>	

ITEM	DESCRIPTION	AMOUNT
<p>A</p>	<p><u>AREA TO BE OCCUPIED BY CONTRACTOR</u></p> <p>The area of the site which may be occupied by the Contractor for use as storage and for the purpose of erecting workshops etc shall be defined on the site by the Engineer</p>	
<p>B</p>	<p><u>PROGRESS SCHEDULE</u></p> <p>Immediately after signing the contract the Contractor is to prepare a Time Progress Chart showing the time and order in which he proposes to carry out the works within the total construction time stated in the contract. The chart will show in detail the construction time and order in which each section of the work is to be carried out and be sub-divided into trades and tasks. If the contractor proposes sectional completion of the project he must plan this in detail including access roads, and services and this shall be reflected on the chart</p> <p>Upon the letting of the Sub-Contractors work the Contractor is to incorporate times and details of each separate Sub-Contractor work which information is to be agreed by the Sub-Contractor and the chart will be so designed to accommodate this infantine.</p> <p>At the end of each week the Contractor is to mark on the chart in a different colour the actual time taken to complete the respective stages and sections of the work. The contractor shall obtain the Engineer's approval on the chart and then shall supply copies to the Engineer and Quantity Surveyor</p> <p>If at any time it should appear to the Engineer that the actual progress of the works does not conform to the approved programme progress schedule the Contractor shall produce at the request of the Engineer a revised programme showing the modifications and accelerations to the approved programme necessary to ensure completion of the works within the agreed contract period.</p> <p>The submission of and approval by the Engineer of such revisions and accelerations shall not entitle the Contractor to any extra payment or extension of time and shall not relieve the Contractor of any duties or obligations or responsibilities under the contract</p>	
	<p>Carried to collection</p>	

ITEM	DESCRIPTION	AMOUNT
<p>A</p>	<p><u>OVERTIME</u></p> <p>The Contractor shall be responsible for any extra costs for overtime working he considers will be necessary in order to complete the works within the contract period or time for completion apart from overtime working which may be authorised by the Engineer</p> <p>If overtime is worked out in accordance with a written instruction issued by the Engineer the contractor will be reimbursed in respect of such overtime to the unproductive time payable over and above the basic hourly rates as laid down by the Regulation of wages and Conditions of employment Act, Building and Construction Industry Wages Council and excluding any bonuses, profits and overheads.</p>	
<p>B</p>	<p><u>WATER</u></p> <p>The contractor shall provide at his own risk and cost all water for use in connection with the works including the work of sub-contractors make arrangements with the local authority for the installation of a separate meter where applicable and possible for all water used by him throughout the contract and pay all costs and fees in connection therewith. He shall also provide temporary storage tanks and tubing etc as he may consider necessary and clear away at completion.</p> <p>The contractor is to provide clean drinking water at the construction site for his workers at all times.</p> <p>All water shall be fresh, clean and pure, free from earthly vegetable or organic matter, acid or alkaline substance in solution or suspension.</p>	
<p>C</p>	<p><u>TELEPHONE</u></p> <p>The contractor shall provide in the office, from the commencement to the completion of the works, a wireless or mobile phone and shall pay all charges or airtime necessary for its use</p>	
<p>D</p>	<p><u>LIGHTING AND POWER</u></p> <p>The contractor shall provide at his own risk and cost all temporary artificial lighting and power for use on the works including all sub-contractors and specialists requirements and including all temporary connections, wiring, fittings etc and clearing away on completion. The Contractor shall pay all fees and obtain all permits in connection therewith.</p>	
	<p>Carried to Collection</p>	

ITEM	DESCRIPTION	AMOUNT
<p>A</p>	<p><u>TESTING</u></p> <p>Allow for all expenses in connection with the testing of materials as specified hereunder including the supply and preparation of materials to be tested, the cost of materials and their packing and conveyance to the nearest approved Testing Laboratory, laboratory charges, etc. The following items of tests will be measured according to the number of tests actually called for by the Engineer but unsuccessful tests will not be included in the remeasurement.</p> <p>Allow for executing the following tests as detailed in the Appendices to these Bills of Quantities (PROVISIONAL))</p> <p>Water Test(litres)</p> <p>Sand Test(m3)</p> <p>Aggregate Test(m3)</p> <p>Reinforcement test (1m of mild steel rod or high tensile steel bar of various sizes)</p> <p>Concrete Test (each test comprising cubes as described hereinafter)</p> <p>Testing of concrete or stone blocks of various strengths in accordance with Kenya Standard Specification (one test comprising blocks)</p>	
	<p>B</p> <p><u>PRICING RATES</u></p> <p>The tenderer shall include for all costs in executing the whole of the works, including transport, replacing damaged items, fixing, all to comply with the said Conditions of Contract.</p>	
	<p>Carried to collection</p>	

ITEM	DESCRIPTION	AMOUNT
A	<p><u>TEMPORARY STRUCTURES</u></p> <p>a) The Contractor shall allow for providing and clearing away on completion of the works such temporary hoarding , rubbish chutes, gates, planked walkways, guard rails etc. as may be necessary for the protection of the workers, the general public, and for the proper execution of the works.</p> <p>b) As such, temporary structures shall be constructed with the approval of the Engineer and to his full satisfaction and in such a manner as to cause minimum intrisiveness and disturbance to occupants of adjacent developments and users of the adjacent roads.</p> <p>c) All such temporary structures shall comply in all aspects with the national laws, rules, and regulations currently in force and applicable to such structures.</p> <p>d) All temporary structures shall be erected in a manner so that the unloading of materials causes minimum obstruction to the use of adjacent roads and other facilities</p> <p>e) All temporary structures shall be kept properly lighted throughout the periods of darkness and any corners or projections shall be painted white.</p> <p>g) Temporary structures shall not be used or permitted to be used for advertisement purposes except with the written consent of the Engineer</p> <p>h) All temporary structures shall be maintained at all times in good order and good condition to the satisfaction of the Engineer.</p> <p>i) All temporary structures shall be removed when so required by the Engineer or at the end of the period for which it is required.</p> <p>j) The Contractor shall indemnify and shall keep the employer idemnified against any expenses, loss, claim or suits arising out of or in connection with the temporary structures.</p>	
	Carried to collection	

ITEM	DESCRIPTION	AMOUNT
A	<p><u>SITE OFFICE</u></p> <p>The contractor shall supply, maintain, service, clean and light a fully furnished, suitable office having an approximate floor area of not less than 200sqm. The office shall have a sample room suitable dimensions with clean running water and electricity connected to the approval of the Engineer.</p> <p>The Contractor shall provide offices, messrooms and all other buildings required by the Contractor for his own use and the use of by Clerk of Works and Nominated SubContractors as required by the items or attendance</p> <p>The site office shall be equipped with a table and chairs of sufficient size and number for site meetings and plan chests for drawings shall also be provided by the contractor</p> <p>The Contractor shall allow for the cost of providing light refreshment for the consultants at site meetings.</p> <p><u>TEMPORARY DISPOSAL OF RAIN WATER</u></p> <p>The Contractor shall provide and maintain all necessary temporary gutters, downpipes, chutes, drains etc. for conveying rainwater from the buildings and storage tanks for rainwater harvesting.</p> <p>The Contractor shall allow for temporary drainage plumbing and piping for keeping the premises and site free from accumulation of water. He shall also allow for construction and maintaining any necessary storm water drainage structures as directed.</p> <p><u>CLEARING AWAY</u></p> <p>The Contractor shall remove all temporary works, rubbish, debris and surplus materials from the site as they accumulate, on intervals as instructed by the Engineer and upon completion of the works, remove and clear away all plant, equipment, rubbish, unused materials and stains and leave in a clean and tidy state to the reasonable satisfaction of the Engineer.</p> <p>The whole of the works shall be delivered up clean, complete and in perfect condition in every respect to the satisfaction of the Engineer.</p>	
	<p>Carried to collection</p>	

ITEM	DESCRIPTION	AMOUNT
A	<p><u>SITE ACCOMODATION & STORAGE</u></p> <p>The Contractor shall provide sheds for storage accommodation for all goods and materials liable to suffer damage from exposure to sunlight or inclement weather.</p> <p>The Contractor shall provide offices, mess rooms and all the buildings required by the Contractor for his own use and the use of Nominated Sub-Contractors as required by the items of attendance only.</p> <p>The Contractor shall provide at his own risk and cost where directed on the site weather proof lock-up sheds and make good damaged or disturbed surfaces upon completion to proof lock-up sheds and make good damaged or disturbed surfaces upon completion to the satisfaction of the Engineer</p> <p>Upon completion all temporary buildings are to be removed and cleared away</p>	
B	<p><u>SANITATION OF THE WORKS</u></p> <p>The sanitation of the works shall be provided, maintained and removed on completion by the Contractor to the satisfaction of the Engineers and local Authorities.</p> <p>The sanitary facilities shall be of generally acceptable standard regardless of the material being used to ensure ease of cleaning and maintain general well being of the users. Their location shall be agreed with the Engineers and the works shall not be commenced before the sanitary accommodation has been approved by the above mentioned authorities.</p> <p>The Contractor will be required to pay all conservancy charges and shall ensure clean daily maintenance and disinfecting of the sanitary facilities, and not less than once per week, the whole area shall be sprayed with disinfectant and insecticides and any temporary drains shall be removed and all works and surfaces disturbed made good and then the whole area disinfected and left clean and free from pollution to the satisfaction of the Engineer and local authorities.</p>	
C	<p><u>HOARDINGS</u></p> <p>The Contractor shall provide, erect and maintain throughout the course of the Contract and thereafter clear away and make good disturbed areas, temporary hoarding; approximate length of 370 metres: 2400mm high above ground consisting of: 100mm diameter timber poles at 1200mm centres firmly founded and secured, 75x50mm horizontal timber rails at 900mm centres, painted GCI sheets, proper timber gates with suitable locks to Engineers approval.</p>	
	<p>Carried to collection</p>	

ITEM	DESCRIPTION	AMOUNT
<p>A</p>	<p><u>DEMOLITIONS AND DOWNTAKINGS</u></p> <p>The Contractor is to allow for all temporary protection required during the works including ordinary and special dust screens, hoardings, barriers, warning signs etc. as directed by the Engineer and as necessary for the adequate protection of adjacent property and finishes, workmen employed upon the site and the public. Any damage or loss incurred due to the insufficiency of such protection must be made good by the Contractor. All protective devices are to be removed on completion of the work and any necessary making good consequent upon this is to be executed to the satisfaction of the Engineer</p> <p>All materials arising from demolitions and downtakings are deemed to be the property of the employer. No claim will be entertained on account of employer exercising this right to retain the materials unless otherwise stated.</p> <p>The Contractor shall allow in his rates the cost of handling and disposal of debris arising out of the demolition works</p> <p>All downtakings shall be carefully removed, taken down, dismantled and stored on site until instructed by the Engineer to remove from the site. Such materials shall only be incorporated in the new works if required by the Engineer in which case appropriate adjustments will be made in the final account for the cost of labour, screws etc for fixing such downtakings in the new works.</p> <p>The Contractor shall be entirely responsible for any breakage or damage which may occur to materials required for re-use, during their removal, unless it is certified by the Engineer that such damage or breakage was inevitable as a result of the condition of the item concerned.</p>	
<p>B</p>	<p><u>ACCESS TO SITE AND TEMPORARY ROADS</u></p> <p>Means of access to the site shall be agreed with the Engineer prior to commencement of the works and the Contractor must allow for building and maintaining any temporary access roads for the transport of materials, plant and workmen as may be required for the complete execution of the works including the provision of temporary culverts, crossings, bridges or any other means of gaining access.</p> <p>Upon the completion the works the Contractor shall remove such temporary roads, temporary culverts bridges etc and make good and reinstate all works and services disturbed to the satisfaction of the Engineer.</p>	
	<p>Carried to collection</p>	

ITEM	DESCRIPTION	AMOUNT
<p data-bbox="175 218 196 239">A</p> <p data-bbox="237 218 386 239"><u>SIGN BOARD</u></p> <p data-bbox="237 277 1170 478">The Contractor shall provide and erect where directed and maintain during the whole period of the building operation and remove at completion, one approved sign board of approximately 3000x3000mm and approximately 5800mm overall height to the Architect's later design giving a brief description of the works, a 3D perspective image of the project, and showing the names of the employer and the consultants, with sufficient space to append the names of the sub-contractors and suppliers when known. The lettering concerning the Architect, Quantity Surveyor and Engineer is not to be more than 50mm high.</p> <p data-bbox="175 516 196 537">B</p> <p data-bbox="237 516 456 537"><u>PRIME COST SUMS</u></p> <p data-bbox="237 575 1170 684">i) The words "Prime Cost" (or the initials "P.C") appearing in the contract documents shall mean net costs exclusive of any trade, cash or other discount whatsoever but inclusive of the costs of the packing, carriage and delivery. Such costs shall be the same due to the sub-contract or supplier after adjustments where applicable in respect of measurements of rates.</p> <p data-bbox="237 722 1170 831">ii) Any increase or decrease in the prime costs sums resulting from the adjustments and properly paid by the contractor shall be added or deducted from the contract sum in the final account. In substantiation the contractor will require to produce to the Quantity Surveyor all quotations, invoices and receipted accounts as shall be necessary to show the details of the sums actually paid.</p> <p data-bbox="237 898 1170 1066">iii) Any sum added by the contractor in these Bills of Quantities in respect of profits upon any prime costs will be deducted at the final settlement of accounts and the sum will be added to the amount of which will bear the same proportion to the sum added as the net amount properly expended to the original P.C sum. The profit is a management fee for arranging and taking responsibility of the sub-contract works or arranging for and checking the supply of materials and goods from nominated suppliers.</p>		
	<p data-bbox="237 1583 440 1604">Carried to collection</p>	

ITEM	DESCRIPTION	AMOUNT
A	<p data-bbox="233 216 610 243"><u>NOMINATED SUB-CONTRACTORS</u></p> <p data-bbox="233 275 1170 331">The contractor shall accept responsibility for providing the following services for nominated sub-contractors.</p> <p data-bbox="233 363 553 390">i) GENERAL ATTENDANCE:</p> <p data-bbox="233 422 1057 449">The following services are described as "allow for general attendance" . This shall mean:</p> <p data-bbox="233 480 1170 600">a) Use for the purpose of the sub-contract works of any scaffolding belonging to or provided by the contractor while it remains so erected upon site, provided that no warranty or other liability on the part of the contractor or of his other sub-contractors shall be created or implied in regard to the fitness, condition or suitability of the said scaffolding</p> <p data-bbox="233 632 1154 659">b) Provision of water, lighting, watching and attendance for the purpose of the sub-contract works.</p> <p data-bbox="233 716 889 743">c) Use of sanitary accommodation, mess rooms and welfare facilities.</p> <p data-bbox="233 779 1125 806">d) Provision of space for erecting of offices or stores or space for storage of plant and materials.</p> <p data-bbox="233 863 540 890">ii) SPECIAL ATTENDANCE:</p> <p data-bbox="233 921 1057 949">The following services are described as "allow for special attendance" . This shall mean:</p> <p data-bbox="233 980 1170 1100">a) Taking delivery and including the provision of unskilled labour necessary to attend upon the sub-contractors workmen for the purpose of unloading plants/equipment and materials of significant weight and/or size, when received upon the site and placing in position within the sub-contractor's storage space or store.</p> <p data-bbox="233 1131 1170 1188">b) Special Scaffolding, scaffolding additional to the Contractors scaffolding or Reassembling of contractor's scaffolding.</p> <p data-bbox="233 1220 922 1247">c) Facilitating special power requirements during the course of the works.</p>	
	<p data-bbox="233 1633 443 1661">Carried to collection</p>	

ITEM	DESCRIPTION	AMOUNT
	<p>CLAIMS</p> <p>A It shall be a condition of this contract that upon it becoming reasonably apparent to the Contractor that he has incurred losses and / or expenses due to any of the contract conditions, or by any other reason whatsoever, he shall present such a claim or intent to claim notice to the Engineer within the contract period. No claim shall be entertained upon the expiry of the said contract period.</p> <p>PAYMENTS</p> <p>B The tenderer's attention is drawn to the fact that the payments shall be made in accordance with Clause 14 of the Conditions of Contract Agreement. In order to facilitate this, a list of the general component elements for the works is given at the summary page of these specifications and the tenderer is requested to break down his tender sum commensurate to the said elements.</p> <p>PREVENTION OF ACCIDENT, DAMAGE OR LOSS</p> <p>C The Contractor is thus instructed to take reasonable care in the execution of the works as to prevent accidents, damage or loss and disruption of activities being carried out. The Contractor shall allow in his rates any expense he deemed necessary by taking such care within the site.</p>	
	<p>Carried to collection</p>	

ITEM	DESCRIPTION	AMOUNT
<p>A</p>	<p><u>NOMINATED SUPPLIERS</u></p> <p>The contractor shall take delivery all materials or goods supplied by the Nominated suppliers and shall sign a receipt as having received them in good order and condition. He shall offload, transport to site, unload, hoist, provide safe storage and thereafter be responsible for any loss or damage or replacement of any such lost or damaged articles at his own expense and shall return case if so required.</p> <p>Provision is made herein following each appropriate P.C sums for the costs of the foregoing services against items reading "take delivery of and fix only"</p> <p><u>Fix Only:-</u></p> <p>"Fix Only" shall mean take delivery on site, unload, store, unpack, assemble as necessary, distribute to position, hoist and fix only.</p>	
<p>B</p>	<p><u>DIRECT CONTRACTS</u></p> <p>Notwithstanding the foregoing conditions, the Government reserves the right to place a "Direct Contract" for any goods or services required in the works which are covered by a P.C. Sum in the Bills of Quantities and to pay for the same direct. In any such instances, profit relative to the P.C. Sum in the priced Bills of Quantities will be adjusted as described for P.C. Sums is allowed.</p>	
<p>C</p>	<p><u>PROTECTION OF THE WORK</u></p> <p>The Contractor shall cover up and protect all finished work liable to damage including provision of temporary roof, gutters, drains etc until the completion of the works.</p> <p>In the event of any damages occurring to the works, materials, sewers, drains, gullies, paths or other works on site in temporary possession of the contractor for the purpose of this contract either from weather, want of proper protection, defects, or insufficiency of the works or any other causes or whatsoever during the progress of the works, the contractor shall be responsible and without extra charge, make good all damage and pay all costs which may be levied.</p> <p><u>BLASTING OPERATIONS</u></p>	
<p>D</p>	<p>Blasting will only be allowed with the express permission of the Engineer in writing. All blasting operations shall be carried out at the Contractor's sole risk and cost in accordance with any Government regulations in force for the time being, and any special regulations laid down by the Engineer governing the use and storage of explosives.</p>	
	<p>Carried to collection</p>	

ITEM	DESCRIPTION	AMOUNT
A	<p><u>PREVENTION OF NUISANCE</u></p> <p>The works and such sections of the site necessary thereafter shall be under the entire care and control of the contractor during the whole period of the contract and shall take all possible precautions to prevent any nuisance, inconvenience or injury to the holder or occupiers of the existing or surrounding properties and to the public generally, and shall at all times keep all paths and roads affected by the works in a safe and clear state, and shall use proper precautions to ensure the safety of all wheeled traffic and pedestrians.</p> <p>The contractor shall provide appropriate screens to seal off the working area.</p> <p><u>REMOVAL OF PLANT AND RUBBISH ETC</u></p> <p>The Contractor shall upon completion of the works remove and clear away all temporary buildings, plant, rubbish and unused materials, and shall leave the whole of the site of the works in a clean and tidy state to the satisfaction of the Engineer. He shall also remove all rubbish and dirt from the site at intervals or as directed by the Engineer.</p> <p>Particular care shall be taken in leaving windows, floors and fittings clean and the removal of all paint and cement stains therefrom.</p> <p>The contractor is expected to have established a well planned method of solid disposal of debris/garbage on and off the camp site</p> <p><u>CONTRACTOR'S SUPERINTENDENCE/SITE AGENT</u></p> <p>The Contractor shall constantly keep on the works a literate English speaking Agent or Representative, competent and experienced in the kind of work involved who shall give his whole experience in the kind of work involved and shall give his whole time to the superintendence of the works.</p> <p>Such Agent or Representative shall receive on behalf of the Contractor all directions and instructions from the Engineer and such directions shall be deemed to have been given to the Contractor in accordance with the Conditions of Contract.</p>	
	<p>Carried to collection</p>	

ITEM	DESCRIPTION	AMOUNT
	<p><u>TRAINING LEVY</u></p> <p>A The Contractor's attention is drawn to legal notice No. 237 of 2007 which requires payment by the Contractor for a training levy and the contractor shall allow in the preliminaries of this contract (basic rates column) for all costs arising or resulting therefrom.</p> <p>Proof of payment of this Levy should be provided at the request of the Engineer</p> <p><u>STANDARDS LEVY</u></p> <p>B The Contractor is required to make payments to the Kenya Bureau of Standards as Standard Levy inline with the current current and prevailing regulations.</p> <p><u>VALUE ADDED TAX (V.A.T.)</u></p> <p>C The Contractor's attention is drawn to V.A.T PUBLIC NOTICE NO. 6 of 5th August, 1993 regarding the Finance Bill 1993 which expanded the V.A.T base to cover construction services amongst other items. The Contractor's attention is also drawn to all other notices issued by the government in relation to taxation. The Contractor shall familiarise himself with the said notices and allow in all his Bills of Quantities rates (Excluding P.C and Provisional Sums) for the net tax. (i.e less input tax where applicable) as required by law.</p> <p>Please note that allowing a lump sum tax either in preliminaries or in summary page shall not be acceptable.</p> <p>Any additional information and assistance concerning the application of the said notice should be directed to the office of the Commissioner of Value Added Tax</p>	
	Carried to collection	

ITEM	DESCRIPTION	AMOUNT
	<u>BILL NO. 2</u>	
	<u>GENERAL PRELIMINARIES</u>	
	<u>COLLECTION</u>	
	Carried from page 1/1	
	Carried from page 1/2	
	Carried from page 1/3	
	Carried from page 1/4	
	Carried from page 1/5	
	Carried from page 1/6	
	Carried from page 1/7	
	Carried from page 1/8	
	Carried from page 1/9	
	Carried from page 1/10	
	Carried from page 1/11	
	Carried from page 1/12	
	Carried from page 1/13	
	Carried from page 1/14	
	Carried from page 1/15	
	Carried from page 1/16	
	Carried from page 1/17	
	Carried from page 1/18	
	Carried from page 1/19	
	Carried from page 1/20	
	Carried from page 1/21	
	Total for General Preliminaries Carried to Summary of Bill No. 2	

ITEM	DESCRIPTION	QTY	UNIT	RATE	AMOUNT
	<u>GROUND FLOOR</u>				
	<u>ELEMENT NO.1</u>				
	<u>SUB-STRUCTURES (ALL -PROVISIONAL)</u>				
	<u>Earthworks & Excavations</u>				
A	Excavate oversite average 300mm deep to remove top soil and turf and cart away.	431	SM		
B	Excavate for foundation trenches NOT exceeding 1.50m deep commencing from reduced level.	129	CM		
C	Ditto but column bases	114	CM		
D	Ditto; exceeding 1.50m deep but not exceeding 3.0m	35	CM		
	<u>Backfilling</u>				
E	Return, fill in and well ram selected excavated materials around foundations	186	CM		
	<u>Disposal</u>				
F	Load and dispose surplus excavated materials in municipal dumping site distance not exceeding 3.00km away	93	CM		
	<u>Hardcore Filling</u>				
G	300mm thick approved hardcore filling well compacted and consolidated in 150mm thick layers	129	CM		
H	50mm thick approved murrum blinding to surface of hardcore	431	SM		
	<u>Anti-Termite Treatment</u>				
I	Rentokil' or other equal and approved insecticide treatment to murrum surface	431	SM		
	<u>DPM Membrane</u>				
J	Polythene; 1000 gauge, 150mm laps [no allowance made] to laps] horizontal; 1 no layer laid on Murrum blinding	431	SM		
	<u>Sawn formwork to</u>				
K	Edges of ground floor slab	118	LM		
	Total Carried to Collection				
	KSS/1				

ITEM	DESCRIPTION	QTY	UNIT	RATE	AMOUNT
	<u>CONCRETE WORKS</u>				
	<u>Vibrated reinforced concrete 2(1:2:4) 20mm aggregate as described in:-</u>				
A	Column bases	27	CM		
B	Columns	3	CM		
C	Strip foundation footing	17	CM		
D	150mm thick ground floor slab	431	SM		
	<u>Plain Concrete (1:4:8) as described in:-</u>				
E	50mm thick blinding in column bases	78	SM		
F	Ditto; strip foundation bases	86	SM		
	<u>Deformed high yield Ribbed bars to B.S 4449, including spacer blocks, cutting, tying and bending:</u>				
G	8mm diameter bars	326	KG		
H	10mm diameter bars	311	KG		
I	12mm diameter bars	1178	KG		
J	16mm diameter bars	757	KG		
	<u>BRC MESH</u>				
K	BRC mesh reinforcement No. 142 weighing 2.22kg per square meters in concrete bed laid in one layer (Measured net allow for over lap)	431	SM		
	<u>Walling</u>				
	<u>Quarry Natural Stone walling in cement and sand (1:4) mortar in:-</u>				
L	200mm thick walls	180	SM		
	Total Carried To Collection				

ITEM	DESCRIPTION	QTY	UNIT	RATE	AMOUNT
	<u>PLINTH</u>				
A	Render; 9 mm (minimum) first coat of cement and sand (1:4); 3 mm second coat of cement and lime putty (1:5) wood floated	38	SM		
B	Prepare and apply two coats of bitumen to plinth surfaces	38	SM		
	<u>PAVING SLAB</u>				
C	50mm thick precast concrete (1:2:4) paving slab each size 600x600mm laid with (1;3) cement sand mortar on and including 50mm thick bed of sand	71	SM		
	Total Carried to Collection				
	<p><u>Collection</u></p> <p>Brought forward from page KSS/1</p> <p>Brought forward from page KSS/2</p> <p>Brought down from Above</p>				
	Total for Element No.1 Substructures Carried to Summary				

ITEM	DESCRIPTION	QTY	UNIT	RATE	AMOUNT
	<u>ELEMENT NO. 2</u>				
	<u>REINFORCED CONCRETE</u>				
	<u>Vibrated reinforced concrete (1:2:4) as discribed to:-</u>				
A	Columns	6	CM		
B	Beams	18	CM		
C	150mm thick suspended slab	431	SM		
	<u>Sawn formwork to</u>				
D	Vertical edge of columns	108	SM		
E	Sides of soffites beams	180	SM		
F	Horizontal soffitties of suspended slab	431	SM		
	<u>Reinforcement (All Provisional)</u>				
	<u>Deformed high yield Ribbed bars to B.S 4449, including spacer blocks, cutting, tying and bending</u>				
G	16mm diameter	3087	KG		
H	12mm diameter bar	309	KG		
I	10mm diameter bar	4368	KG		
J	8mm diameter bar	749	KG		
	Total for Element No.2 Ground Floor Frame Carried to Summary				

ITEM	DESCRIPTION	QTY	UNIT	RATE	AMOUNT
A	<p><u>ELEMENT NO.3</u></p> <p><u>WALLING</u></p> <p><u>External & Internal Walling</u></p> <p>200mm thick approved chisel dressed on both sides natural stone walling laid with (1;4) cement sand mortar with and including hoop iron in every second course</p>	261	SM		
	Total for Element No.3 Ground Floor Walling Carried to Summary				

ITEM	DESCRIPTION	QTY	UNIT	RATE	AMOUNT
A	<p><u>ELEMENT NO.4</u></p> <p><u>DOORS</u></p> <p><u>Steel Panel Doors</u></p> <p><u>Mild steel casement doors; 50x50x3mm thick frame plugged to concrete or blockwork with 100mm long fishtailed 25x25x2mm thick angle section, 50x50x3mm thick angle section frames at 300mm centres both sides, angles cut, mitred and welded: panels infilled 18 gauge MS plates, one coat manufacturer's primer, complete with all necessary ironmongery; all welding ground to smooth finish</u></p> <p>50mm thick Single door size 1500x2700 in rectangular hollow section steel frame work and gauge 18 steel plate panels and upper and upper part open for glazing all to approval</p>	4	NO		
B	<p><u>Prime only back frame with aluminium or other equal and approval primer before fixing as described</u></p> <p>Prepare and apply three coats of gloss paint to steel door</p>	33	SM		
	Total for Element No.4 Ground Floor Doors Carried to Summary				

ITEM	DESCRIPTION	QTY	UNIT	RATE	AMOUNT
	<u>ELEMENT NO.5</u>				
	<u>WINDOWS</u>				
	<u>Supply and fix the following purpose made composite windows in 32mm mild steel "Z" Sections complete with fixing lugs to walls and bedding and pointing all round frame in cement and sand (1:4) mortar; heavy duty brass window stays, handles, couplings and fasteners, with 100mm wide build - in permanent vents to full width of the window where shown, infilled with both 5mm and 1mm gauge mosquito gauze and vents with 16mm gauze x 215mm(overall) girth spray painted hood canopy twice bent and fillet welded 32mm wide onto window framing:-</u>				
A	Window size 2400x1800mm high	8	NO		
B	Window size 2400x1500mm high	8	NO		
	<u>Glazing</u>				
C	4mm clear sheet glass in panes n.e 0.1 sm	64	SM		
	<u>Cill</u>				
D	45mm thick Institu concrete cill reinforced, weathered and throated	47	LM		
	<u>Prepare and apply one undercoat and two finishing coats of prime grade gloss paint to:-</u>				
E	Windows generally of metal internally	64	SM		
F	Windows general surface of metal externally	64	SM		
	Total for Element No.5 Ground Floor Windows Carried to Summary				

ITEM	DESCRIPTION	QTY	UNIT	RATE	AMOUNT
	<u>ELEMENT NO.6</u>				
	<u>BUILDING FINISHES</u>				
	<u>FLOORS</u>				
	<u>24mm thick cement sand screed (1:4) including 20x4mm thick plastic terrazzo strips to approved approved pattern to receive terrazzo to:-</u>				
A	Ground floor surface bed	431	SM		
	<u>Polished white cement based terrazzo</u>				
B	15mm terrazzo laid on screed (m/s) including polishing to smooth	431	SM		
	<u>Wall Finishes</u>				
	<u>Internal Wall Finishes</u>				
	<u>Gauged Plaster (1:1:9) with steel trowel finish in:-</u>				
C	15mm thick to walls or concrete surfaces	303	SM		
	<u>Painting and Decorating</u>				
	<u>Prepare surfaces and apply three coats "Plascon Kansai" paint or other equal and approved on plastered masonry or concrete surfaces to:</u>				
D	Plastered vertical surfaces	303	SM		
	Total Carried to Collection				

ITEM	DESCRIPTION	QTY	UNIT	RATE	AMOUNT
A	<p><u>Fair Face</u></p> <p>Extra-over stone walls for wire brushing and pointing key joints with cement and mortar (1:4)</p>	174	SM		
B	<p><u>Cement and Sand Render to:-</u></p> <p>Reinforced concrete surfaces</p>	126	SM		
C	<p><u>Painting and Decorating</u></p> <p><u>Prepare surfaces and apply three coats "Plascon Kansai" paint or other equal and approved on plastered masonry or concrete surfaces to:</u></p> <p><u>Externally on:-</u></p> <p>Rendered Surfaces</p>	126	SM		
D	<p><u>Ceiling Finishes</u></p> <p><u>Cement and Sand Render to:-</u></p> <p>12mm thick cement lime sand (1:1:6) plaster to horizontal soffit of suspended slab not exceeding 2700mm from floor</p>	431	SM		
E	<p><u>Prepare surfaces and apply three coats "Plascon Kansai" paint or other equal and approved on plastered masonry or concrete surfaces to:</u></p> <p>Prepare and apply one undercoat and two finishing coat of prime grade plastic emulsion paint to plastered ceiling surfaces 2700 high from to floor slab</p>	431	SM		
	Total Carried to Collection				
	<p><u>COLLECTION</u></p> <p>Brought forward from page KSS/8</p> <p>Brought down fom above</p>				
	Total for Element No.6 Ground Floor Building Finishes Carried to Summary				

ITEM	DESCRIPTION	QTY	UNIT	RATE	AMOUNT
	<u>ELEMENT No.07</u>				
	<u>STAIRS & PASSAGE BALLUSTRADE (ALL PROVISIONAL)</u>				
	<u>The following in 1 No. Stair cases</u>				
	<u>Vibrated reinforced concrete (1:2:4) aggregate as described in:-)</u>				
A	150mm thick Landing	3	SM		
B	Stairs	2	CM		
C	Stair beam	2	CM		
	<u>Sawn formwork as described</u>				
D	Soffities of sloping stairs	8	SM		
E	Sides od stair beam	6	SM		
F	Ditto Landing	4	SM		
G	Edge of sloping stairs cut to profile of treads and rises 250mm overall (255-300 girth)	22	LM		
H	Edge of landing 75-150mm girth	6	LM		
I	Ditto vertical edge of riser 175m high	6	LM		
	<u>Stair finishes 32mm cement sand (1:4) screed</u>				
J	20mm thick paving to riser 175mm high	22	LM		
K	Ditto to tread 300mm wide	22	LM		
L	Ditto to sloping edge of stairs of profile to riser and treads 300mm overall girth	6	LM		
M	Ditto to landing	6	SM		
N	Ditto vertical sides of landing 150mm high	6	LM		
	Total Carried to Collection				

KSS/10

ITEM	DESCRIPTION	QTY	UNIT	RATE	AMOUNT
	<u>Cement sand (1:1:6) lime plaster as described to:-</u>				
A	12mm thick in two coats of slopping of stairs	8	SM		
B	Ditto to soffites of landing	4	SM		
	<u>Balustrading</u>				
C	75mmx25mm rectangular hollow section steel top and bottom rails	120	LM		
D	75mm x25mm Thicks RHS middle rail	60	LM		
E	25x25x3mm thick RHS middle baluster 1200mm twice counter sunk, one end fanged and built into concrete bed (M.S)	250	NO		
	<u>Sundries</u>				
F	Weld baluster to metal rail	75	NO		
G	Extra over baluster for fanged end	38	NO		
H	Make hole in reinforced concrete for fanged end and make good in cement sand mortar	77	NO		
	Total Carried to Collection				

ITEM	DESCRIPTION	QTY	UNIT	RATE	AMOUNT
	<u>Prepare and apply three coats of gloss paint to:-</u>				
A	Metal surface girth 100-200mm	180	LM		
B	Ditto girth not exceeding 100mm	110	LM		
C	Prepare and apply three coats of clear varnish on general surface of wood girth 200-300mm	30	LM		
	<u>Reinforcement</u>				
D	12mm diameter square twisted bar (Provisional)	576	KG		
E	10mm ditto (Provisional)	368	KG		
	Total Carried to Collection				
	<u>COLLECTION</u>				
	Brought down from page KSS/10				
	Brought down from page KSS/11				
	Brought down above				
	Total for Element No.7 Ground Stairs & Passage Balustrades Carried to Summary				

ITEM	DESCRIPTION	QTY	UNIT	RATE	AMOUNT
	<u>GROUND FLOOR WORKS -SUMMARY</u>				
1	SUBSTRUCTURES FROM PAGE KSS/3				
2	GROUND FLOOR FRAME PAGE KSS/4				
3	GROUND FLOOR WALLING FROM PAGE KSS/5				
4	GROUND FLOOR DOORS FROM PAGE KSS/6				
5	GROUND FLOOR WINDOWS FROM PAGE KSS/7				
6	GROUND FLOOR BUILDING FINISHES FROM PAGE KSS/9				
7	GROUND FLOOR STAIRS AND PASSAGE BALUSTRADE FROM PAGE KSS/12				
	TOTAL FOR GROUND FLOOR WORKS CARRIED TO GRAND SUMMARY				

ITEM	DESCRIPTION	QTY	UNIT	RATE	AMOUNT
	<u>FIRST FLOOR</u>				
	<u>ELEMENT NO. 01</u>				
	<u>REINFORCED CONCRETE</u>				
	<u>Vibrated reinforced concrete (1:2:4) as discribed to:-</u>				
A	Columns	6	CM		
B	Beams	18	CM		
	<u>Sawn formwork to</u>				
C	Vertical edge of columns	108	SM		
D	Sides of soffites beams	180	SM		
	<u>Reinforcement (All Provisional)</u>				
	<u>Deformed high yield Ribbed bars to B.S 4449, including spacer blocks, cutting, tying and bending</u>				
E	16mm diameter	3087	KG		
F	12mm diameter	308	KG		
G	8mm diameter bar	1148	KG		
	Total for Element No.1 First Floor Frame Carried to Summary				

ITEM	DESCRIPTION	QTY	UNIT	RATE	AMOUNT
A	<p><u>ELEMENT No.2</u></p> <p><u>WALLING</u></p> <p><u>External & Internal Walling</u></p> <p>200mm thick approved chisel dressed on both sides natural stone walling laid with (1;4) cement sand mortar with and including hoop iron in every second course</p>	261	SM		
	Total for Element No.2 First Floor Walling Carried to Summary				

ITEM	DESCRIPTION	QTY	UNIT	RATE	AMOUNT
	<p><u>ELEMENT No.3</u></p> <p><u>DOORS</u></p> <p><u>Steel Panel Doors</u></p> <p><u>Mild steel casement doors; 50x50x3mm thick frame plugged to concrete or blockwork with 100mm long fishtailed 25x25x2mm thick angle section, 50x50x3mm thick angle section frames at 300mm centres both sides, angles cut, mitred and welded; panels infilled 18 gauge MS plates, one coat manufacturer's primer, complete with all necessary ironmongery; all welding ground to smooth finish</u></p> <p>A 50mm thick Single door size 1500x2700 in rectangular hollow section steel frame work and gauge 18 steel plate panels and upper and upper part open for glazing all to approval</p> <p><u>Prime only back frame with aluminium or other equal and approval primer before fixing as described</u></p> <p>B Prepare and apply three coats of gloss paint to steel door</p>	4	NO		
	Total for Element No.3 First Floor Doors Carried to Summary				

ITEM	DESCRIPTION	QTY	UNIT	RATE	AMOUNT
	<u>ELEMENT No.4</u>				
	<u>WINDOWS</u>				
	<u>Supply and fix the following purpose made composite windows in 32mm mild steel "Z" Sections complete with fixing lugs to walls and bedding and pointing all round frame in cement and sand (1:4) mortar; heavy duty brass window stays, handles, couplings and fasteners, with 100mm wide build - in permanent vents to full width of the window where shown, infilled with both 5mm and 1mm gauge mosquito gauze and vents with 16mm gauze x 215mm(overall) girth spray painted hood canopy twice bent and fillet welded 32mm wide onto window framing:-</u>				
A	Window size 2400x1800mm high	8	NO		
B	Window size 2400x1500mm high	8	NO		
	<u>Glazing</u>				
C	4mm clear sheet glass in panes n.e 0.1 sm	64	SM		
	<u>Cill</u>				
D	45mm thick Institu concrete cill reinforced, weathered and throated	47	LM		
	<u>Prepare and apply one undercoat and two finishing coats of prime grade gloss paint to:-</u>				
E	Windows generally of metal internally	64	SM		
F	Windows general surface of metal externally	64	SM		
	Total for Element No.4 First Floor Windows Carried to Summary				

ITEM	DESCRIPTION	QTY	UNIT	RATE	AMOUNT
	<u>ELEMENT NO.5</u>				
	<u>BUILDING FINISHES</u>				
	<u>FLOORS</u>				
	<u>24mm thick cement sand screed (1:4) including 20x4mm thick plastic terrazzo strips to approved approved pattern to receive terrazzo to:-</u>				
A	Ground floor surface bed	404	SM		
	<u>Polished white cement based terrazzo</u>				
B	15mm terrazzo laid on screed (m/s) including polishing to smooth	404	SM		
	<u>Wall Finishes</u>				
	<u>Internal Wall Finishes</u>				
	<u>Gauged Plaster (1:1:9) with steel trowel finish in:-</u>				
C	15mm thick to walls or concrete surfaces	303	SM		
	<u>Painting and Decorating</u>				
	<u>Prepare surfaces and apply three coats "Plascon Kansai" paint or other equal and approved on plastered masonry or concrete surfaces to:-</u>				
D	Plastered vertical surfaces	303	SM		
	Total Carried to Collection				

ITEM	DESCRIPTION	QTY	UNIT	RATE	AMOUNT
	<u>Fair Face</u>				
A	Extra-over stone walls for wire brushing and pointing key joints with cement and mortar (1:4)	174	SM		
	<u>Cement and Sand Render to:-</u>				
B	Reinforced concrete surfaces	126	SM		
	<u>Painting and Decorating</u>				
	<u>Prepare surfaces and apply three coats "Plascon Kansai" paint or other equal and approved on plastered masonry or concrete surfaces to:</u>				
	<u>Externally on:-</u>				
C	Rendered Surfaces	126	SM		
	<u>Ceiling Finishes</u>				
	<u>Chipboard Ceiling</u>				
D	12mm thick chipboard ceiling panels V-jointed all edges and fixed to 75 & 50mm sawn cypress brandering (m.s) at 600mm centers both ways	431	SM		
E	Extra - over chipboard for access panel door size 625 x 625mm framed all round including cutting and trimming opening	4	NO		
	<u>Brandering</u>				
F	50mm x 50mm	1407	LM		
G	25mm wrot cypress coved cornice	228	LM		
	<u>Prepare and apply three coats First Grade Plastic Emulsion Paints to:-</u>				
H	Prepare and apply one undercoat and two finishing coats of prime grade plastic emulsion paint to ceiling surface 2550 high form to floor slab	431	SM		
	Total Carried to Collection				
	<u>COLLECTION</u>				
	Brought forward from page KSS/18				
	Brought down fom above				
	Total for Element No.5 First Floor Building Finishes Carried to Summary				

ITEM	DESCRIPTION	QTY	UNIT	RATE	AMOUNT
	<u>ELEMENT NO. 06</u>				
	<u>ROOFING AND RAINWATER DISPOSAL</u>				
	<u>Sawn cypress impregnated with tanalith 'c' seasoned to an equilibrium moisture content 9%-15% and to a requirement of KS 02771 of 1991 including templates, fillets, nailing, streaps, splices and hoisting some to 3000mm above ground level</u>				
A	150x50mm rafter	316	LM		
B	100x50mm struts or tie	336	LM		
C	100x50mm wall plate	120	LM		
D	150x 50mm tie beam	283	LM		
E	100x 50mm king post	67	LM		
F	75x50mm purlin	576	LM		
G	200x25 fascia board or barge board	127	LM		
	<u>Roof Covering</u>				
	<u>28 Gauge BP950 Profiled Roofing Sheets (762mm effective cover) in:-</u>				
H	Roof Covering fixed to slope not exceeding 22.5° fixed to purlins (m.s)	466	SM		
	<u>Prepare and apply three coats of prime grade gloss paint to:-</u>				
I	Fascia board; General surface of good girth 200-300mm	127	LM		
Total for Element No. 06 Roofing & Rainwater Goods Carried to Grand summary					

ITEM	DESCRIPTION	QTY	UNIT	RATE	AMOUNT
	<u>FIRST FLOOR WORKS - SUMMARY</u>				
1	FIRST FLOOR FRAME PAGE KSS/14				
2	FIRST FLOOR WALLING FROM PAGE KSS/15				
3	FIRST FLOOR DOORS FROM PAGE KSS/16				
4	FIRST FLOOR WINDOWS FROM PAGE KSS/17				
5	FIRST FLOOR BUILDING FINISHES FROM PAGE KSS/19				
6	FIRST FLOOR ROOFING & RAINWATER GOODS FROM PAGE KSS/20				
TOTAL FOR FIRST FLOOR WORKS CARRIED TO GRAND SUMMARY					

ITEM	DESCRIPTION	UNIT	QTY	RATE	KSHS. CTS.
	<u>REINFORCED CONCRETE RAMP</u>				
	<u>ELEMENT NO. 1</u>				
	<u>SUBSTRUCTURES</u>				
	<u>(ALL PROVISIONAL)</u>				
	<u>Site Clearance</u>				
A	Clear site of all vegetation including small trees, scrubs and bushes; grub up roots; load and cart away material to spoil.	SM	112		
	<u>Excavation</u>				
B	Oversite excavation to reduce levels; average depth of 200mm.	SM	112		
C	Excavate pits for column bases: depth not exceeding 1.50m commencing from stripped level	CM	63		
	<u>Return, fill and ram</u>				
D	Approved fillings around columns and sub-walls: backfill, water and compact in 150 mm layers; allow for filling in selected excavated material or imported materials.	CM	49		
	<u>Removal of surplus materials</u>				
E	Remove surplus excavated spoil from site to a place approved by the local authority.	CM	14		
	<u>Plunking and strutting</u>				
F	Allow for upholding and supporting sides of excavations including any necessary plunking and strutting.	ITEM			
	<u>Disposal of Water</u>				
G	Maintain all substructural works free from water by removing stagnant, running, rain or spring water existing on site	ITEM			
	CARRIED TO COLLECTION				

ITEM	DESCRIPTION	UNIT	QTY	RATE	KSHS. CTS.
A	<u>In situ concrete Class 15MPa: vibrated:</u> 50mm Thick blinding under column bases.	SM	32		
B	<u>In situ concrete class 25MPa: vibrated: reinforced</u> Column bases.	CM	14		
C	Columns.	CM	3		
D	<u>Ribbed reinforcement steel bars to KS 573:2014 : Grade 500 high tensile strength including bends, hooks, tying wire and distance blocks: to S.E's detail (Provisional):-</u> 8mm bars.	KG	86		
E	12mm bars.	KG	459		
F	16mm bars.	KG	758		
G	<u>Modular steel frame with steel plates covering formwork and/or marine board formwork: to:</u> Sides; columns	SM	36		
CARRIED TO COLLECTION					
<u>COLLECTION</u>					
Brought forward from RCR/1					
Brought forward from Above					
TOTAL					
SUBSTRUCTURES					

ITEM	DESCRIPTION	UNIT	QTY	RATE	KSHS. CTS.
	<u>SUPERSTRUCTURES</u>				
	<u>Formwork</u>				
	<u>Modular steel frame with steel plates covering formwork and/or marine board formwork: to</u>				
A	Sides; columns.	SM	36		
B	Horizontal soffits: ramp landings	SM	29		
C	Sides and soffits: ramp beams	SM	72		
D	Slopping soffits: ramps	SM	55		
E	Edges: ramps, 75 - 150mm girth	LM	74		
	<u>Ribbed reinforcement steel bars to KS 573:2014 : Grade 500 high tensile strength including bends, hooks, tying wire and distance blocks: to S.E's detail (Provisional)</u>				
F	8mm bars.	KG	174		
G	10mm bars.	KG	853		
H	16mm bars.	KG	929		
	<u>In situ concrete class 25MPa: vibrated: reinforced</u>				
I	Beams: Ramps	CM	5		
J	Columns.	CM	3		
K	150mm Thick landings.	SM	29		
L	150mm Thick ramp, laid to slopes over 15 degrees from horizontal, surface tamped finish in herring bone ribbed pattern.	SM	55		
	SUPERSTRUCTURES CARRIED TO COLLECTION				

ITEM	DESCRIPTION	UNIT	QTY	RATE	KSHS. CTS.
	<p><u>BALUSTRADING AND RAILING</u></p> <p><u>Ramp Edges</u></p> <p><u>Railing</u></p> <p><u>All steel work shall be primed with two coats zinc chromate primer before fixing and touched up with one coat after fixing. Prices shall include cost of steel members, assembling, fixing in position and of all associated gusset plates, cleats, caps, splice plates, brackets, stiffeners and any other sundries; weight of the sundries is aggregated with the weight of the member to which they are attached; All to be in accordance to the Architect's details and approval:-</u></p> <p><u>The following in Grade 43A structural steel comprising 100 x 4 mm SHS Vertical members, 100 x 50 x 4mm thick RHS Top and bottom rails and 50 x 50 x 3mm thick SHS balusters, hoisted and fixed approximately 1500mm high including fixing and making good concrete surfaces to tops of Reinforced Concrete Wall:-</u></p> <p><u>Independent Members</u></p> <p>A 75 x 50 x 4mm RHS (7.13kg/m) top and bottom rails</p> <p>B 40 x 40 x 3mm RHS (3.36kg/m) internal members.</p> <p><u>Painting & Decoration</u></p> <p>C Prepare and apply 3 coats of gloss oil paint to metal, all sides, measured flat.</p>				
	TOTAL				
	BALUSTRADING AND RAILING				

ITEM	DESCRIPTION	UNIT	QTY	RATE	KSHS. CTS.
	<u>ROOFING & RAINWATER DISPOSAL</u>				
	<u>(ALL PROVISIONAL)</u>				
	<u>Roof Covering</u>				
	<u>Galvanized Corrugated Iron (GCI) 28 Gauge roofing sheets (or other equal and approved) laid on purlins to main roof level; as described to:-</u>				
A	Coverings to 22.5 degrees slopping timber framed roof: nailed every third course.	SM	178		
	<u>Roof Structure</u>				
	<u>Structural timbers; sawn cypress; pressure impregnated:-</u>				
	<u>The following in 10 No. double pitch trusses; 7000mm clear span; including hoisting and fixing in position approx 3000mm above ground floor; including all necessary jointing.</u>				
	<u>Rafters</u>				
A	100 x 50mm	LM	117		
	<u>Tie Beam</u>				
B	150 x 50mm	LM	78		
	<u>Struts/ ties</u>				
C	100 x 50mm	LM	134		
	<u>King posts</u>				
D	100 x 50mm	LM	34		
	<u>Common Rafters , walls plates etc</u>				
	<u>Wall plate</u>				
	<u>Secured with and including 12mm diameter m.s anchor bolt 300mm long at 900mm centres cast in concrete ring beam(m/s)</u>				
E	100 x 50mm	LM	88		
	<u>Purlins</u>				
F	75 x 50mm	LM	212		
	<u>Ceiling Finishes</u>				
	<u>Chipboard Ceiling</u>				
G	12mm thick chipboard ceiling panels V-jointed all edges and fixed to 75 & 50mm sawn cypress brandering (m.s) at 600mm centers both ways	SM	84		
	<u>Brandering</u>				
H	50mm x 50mm	LM	239		
I	25mm wrot cypress covered cornice	LM	48		
	<u>Prepare and apply three coats First Grade Plastic Emulsion Paints to:-</u>				
J	Prepare and apply one undercoat and two finishing coats of prime grade plastic emulsion paint to ceiling surface 2550 high form to floor slab	SM	84		
	<u>ROOFING CARRIED TO COLLECTION</u>				

ITEM	DESCRIPTION	UNIT	QTY	RATE	KSHS. CTS.
	<u>REINFORCED CONCRETE RAMP</u>				
	<u>SUMMARY PAGE</u>				
	<u>BUILDER'S WORK</u>				
	<u>ELEMENT</u>			<u>PAGE NO.</u>	
1	SUBSTRUCTURES		:	RCR/2	
2	SUPERSTRUCTURES		:	RCR/3	
3	BALUSTRADING AND RAILING		:	RCR/4	
4	ROOFING		:	RCR/5	
	TOTAL				
	REINFORCED CONCRETE RAMP				
	RCR/6				

ITEM	DESCRIPTION	QTY	UNIT	RATE	AMOUNT
	<u>PRIME COSTS AND PROVISIONAL SUMS</u>				
A	Allow a Prime Cost Sum of Kenya Shillings One Million (Kshs 1,000,000.00) only for Electrical Installation Works		SUM		
B	Allow a Provisional Sum of Kenya Shillings Three Hundred Thousand (Kshs 300,000.00) only for Contingencies		SUM		
C	Allow a Provisional Sum of Kenya Shillings Seven Hundred And Fifty Thousand (Kshs 750,000.00) for Project Management Expenses		SUM		
D	Allow a Provisional Sum of Kenya Shillings Four Hundred Thousand (Kshs 400,000.00) only for First Floor Verandah Grills & Balustrades		SUM		
Total for Prime Cost & Provisional Sums Carried to Grand Summary					

ITEM	DESCRIPTION	QTY	UNIT	RATE	AMOUNT
<u>GRAND SUMMARY</u>					
A	PARTICULAR PRELIMINARIES				
B	GENERAL PRELIMINARIES				
C	GROUND FLOOR FROM PAGE KSS/13				
D	FIRST FLOOR FROM PAGE KSS/21				
E	REINFORCED CONCRETE RAMP FROM PAGE RCR/6				
F	PROVISIONAL SUMS FROM PAGE KSS/22				
TOTAL FOR WORKS TO FORM OF TENDER					

Contractor's Name _____

Address _____

Signature _____

Date _____

Witnesses's Name _____

Address _____

Signature _____

Date _____

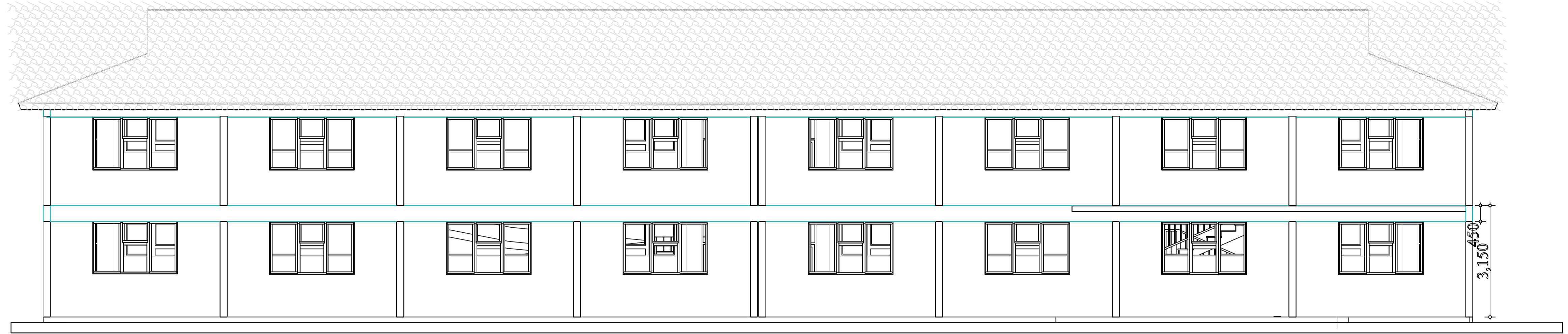

REAR ELEVATION

REAR ELEVATION

Elevation (2)

1:74.66

ROOF DETAILS
 G 28 Pre-painted ridge capping
 G 28 Pre-painted roofing sheets as versatile or equal and approved.
 100 x 50 mm calced timber cypress tie beams
 Ditto king posts/struts/ties
 Ditto wall plate anchored to ring beam.
 75 x 50 mm calced timber cypress purlins.

200 x 25 mm plained and chamfered fascia board
 (Apply 2 coats gloss oil paint undercoat before fixing)

300 x 150 mm x G 26 prefabricated galvanized plate
 box gutters complete with swan neck, down 75 mm diameter pipes and horse shoes.

Dressed natural stone walling keyed externally, plastered and painted internally

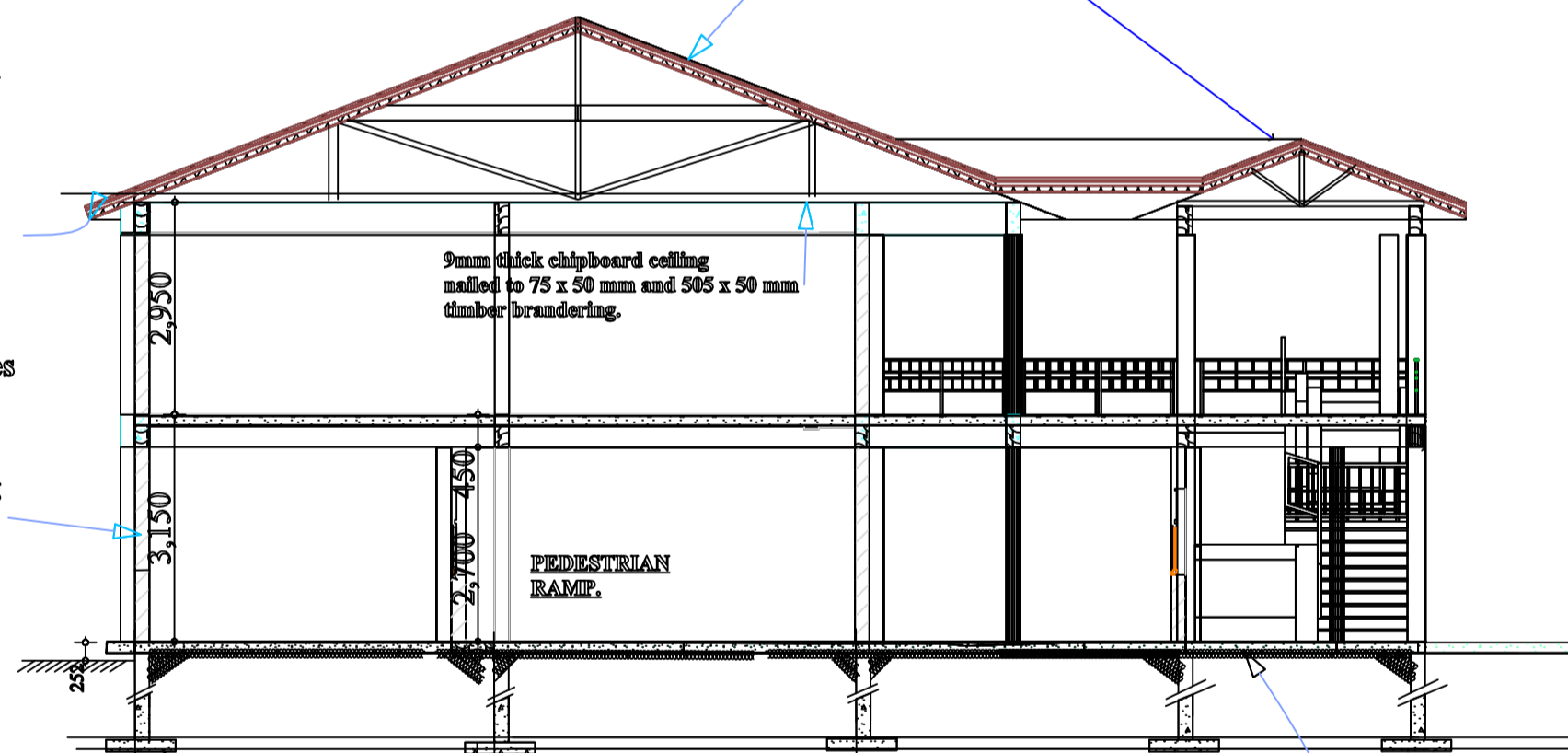

100 mm thick IRC floor slab on G 500 DPM on 50mm well rammed murrum blinding. (Treat blinding with aldrax or other equal and approved insecticide)

300 mm thick handpacked hard core fill below floor.

SECTION A-A

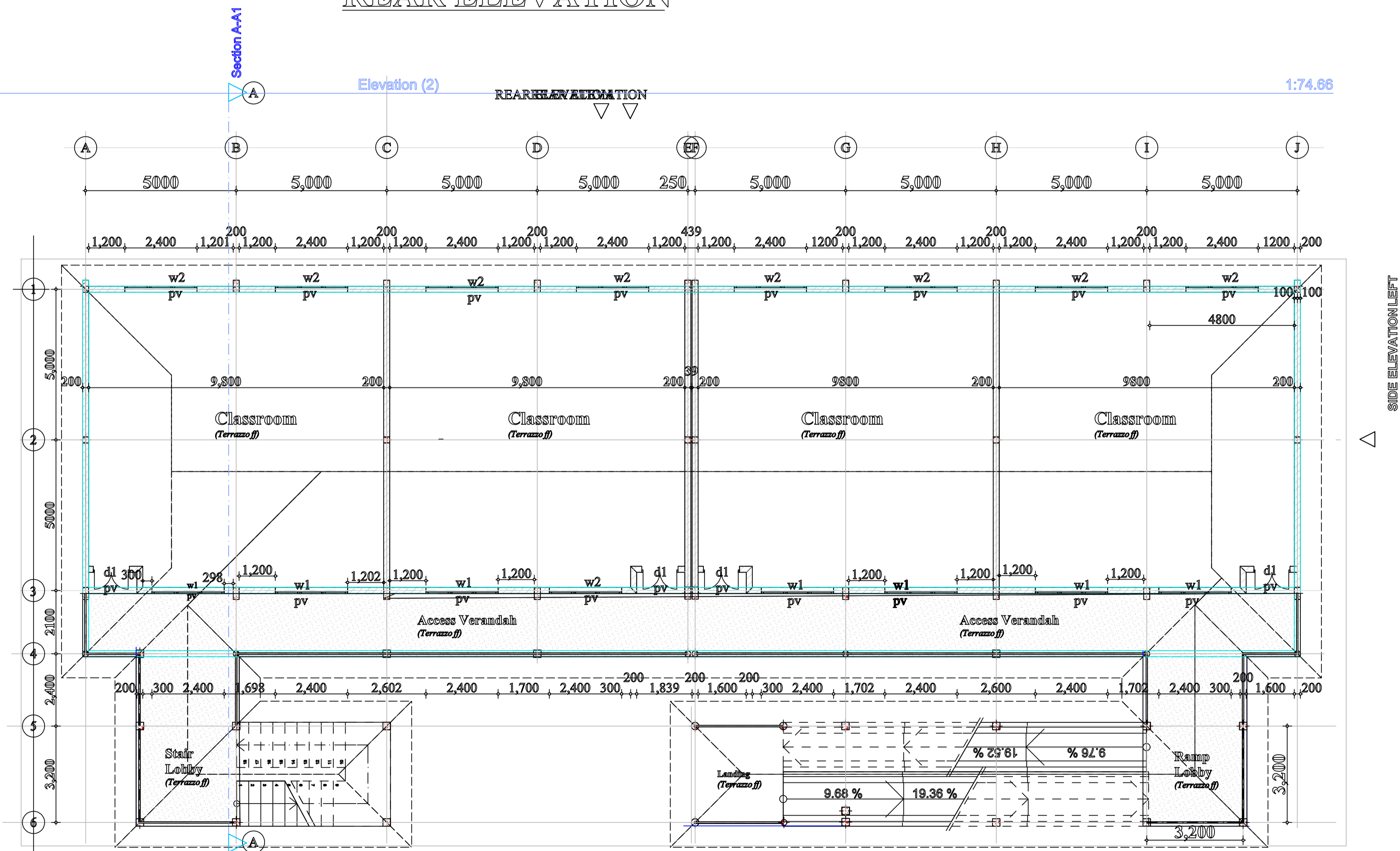

FIRST FLOOR PLAN
 FRONT ELEVATION

Section A-A1

Building Section (1)

1:100

Client/Agency	Project	Drawing Title	Scales	NAME	SIGNATURE	DATE	APPROVALS		CONSULTANT
							Name	Designation	
THE BOARD OF MANAGEMENT, KOMBE SEC. SCHOOL	PROPOSED CONSTRUCTION OF 8 NO CLASSROOMS (DOUBLE STOREY)	Floor plan Section Elevations Details	A 1:100	Design			Name		DEPARTMENT OF TRANSPORT AND INFRASTRUCTURE State Department For Public Works P. O. Box 87- 30300 KAPSABET For The Government of the Republic Of Kenya
				Drawn			Designation		
				Checked			Signature		
			B	CWO			Date		
			C	Misc.					

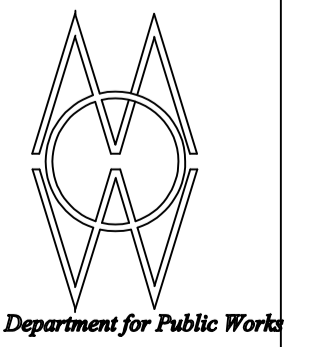

State Department for Public Works

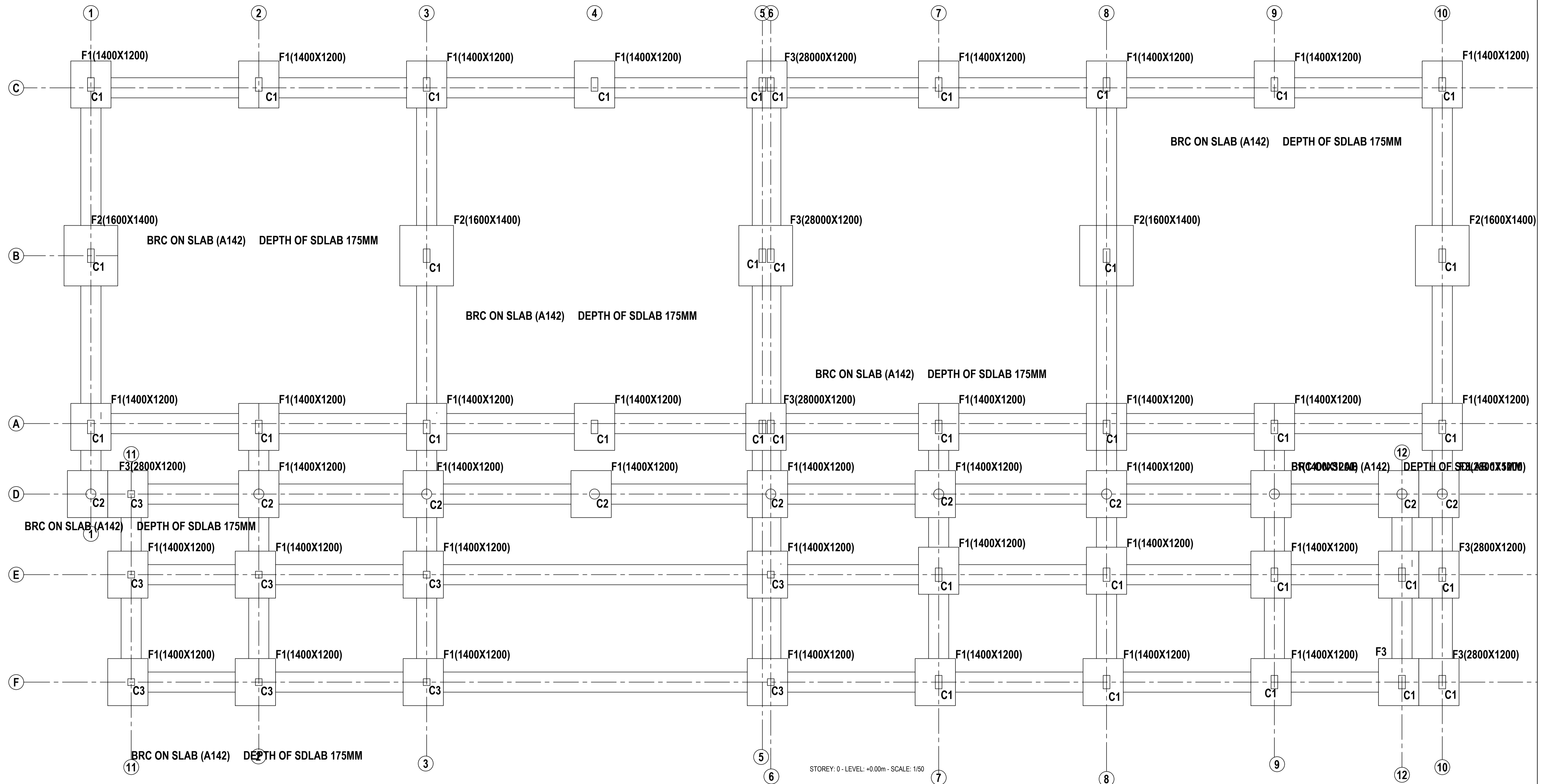

Client/Agency	Project	Drawing Title	Scale	NAME	SIGNATURE	DATE	APPROVALS		CONSULTANT	 DEPARTMENT OF TRANSPORT AND INFRASTRUCTURE <i>State Department For Public Works</i> P.O.Box, 87- 30300 KAPSABET For The Government of the Republic Of Kenya
THE BOARD OF MANAGEMENT, KOMBE DAY SEC. SCHOOL	PROPOSED CONSTRUCTION OF 8 NO CLASSROOMS (DOUBLE STOREY)	FOUNDATION LAYOUT	A 1:100	Design	J.K.KIRWA		Name			
				Drawn	J.K.KIRWA		Designation			
				Checked	J.K.KIRWA		Signature			
				CWO	J.K.KIRWA		Date	May 2026		
			C	Msc.	_____					

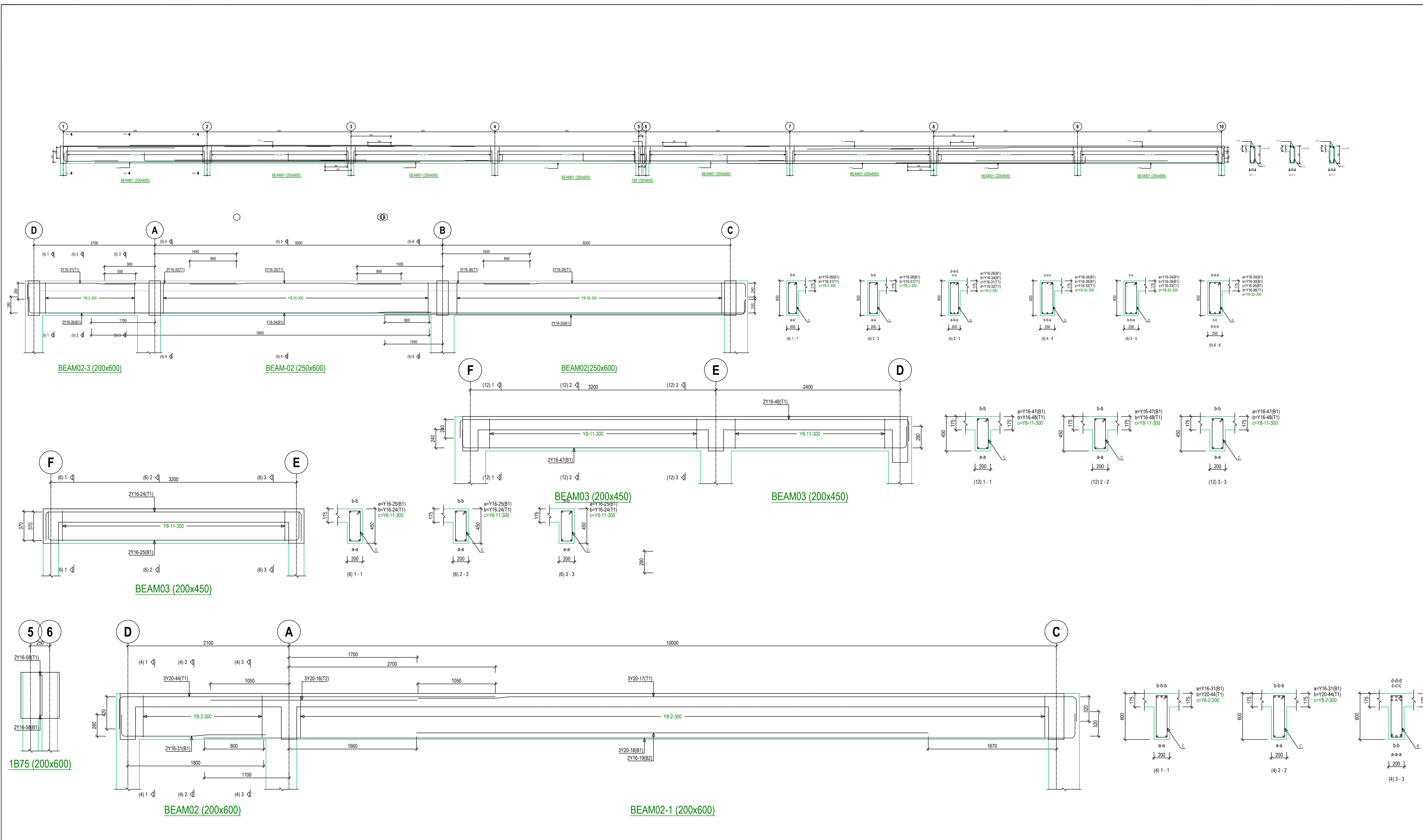

Client/Agency	Project	Drawing Title	Scales		NAME	SIGNATURE	DATE	APPROVALS		CONSULTANT
			A	B				Name	Designation	
THE BOARD OF MANAGEMENT, KOMBE DAY SEC. SCHOOL	PROPOSED CONSTRUCTION OF 8 NO CLASSROOMS (DOUBLE STOREY)	BEAM DETAILS			Design	J.K.KIRWA			Name	DEPARTMENT OF TRANSPORT AND INFRASTRUCTURE State Department For Public Works P.O.Box, 87- 30300 KAPSABET For The Government of the Republic Of Kenya
					Drawn	J.K.KIRWA			Designation	
			A	1:100	Checked	J.K.KIRWA			Signature	
			B		CWO	J.K.KIRWA			Date	
			C		Msc.					

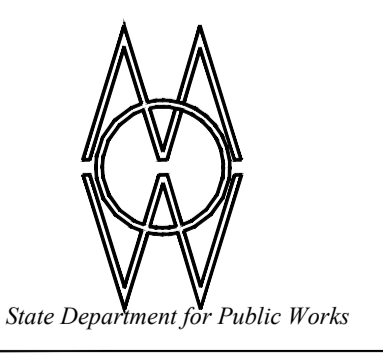

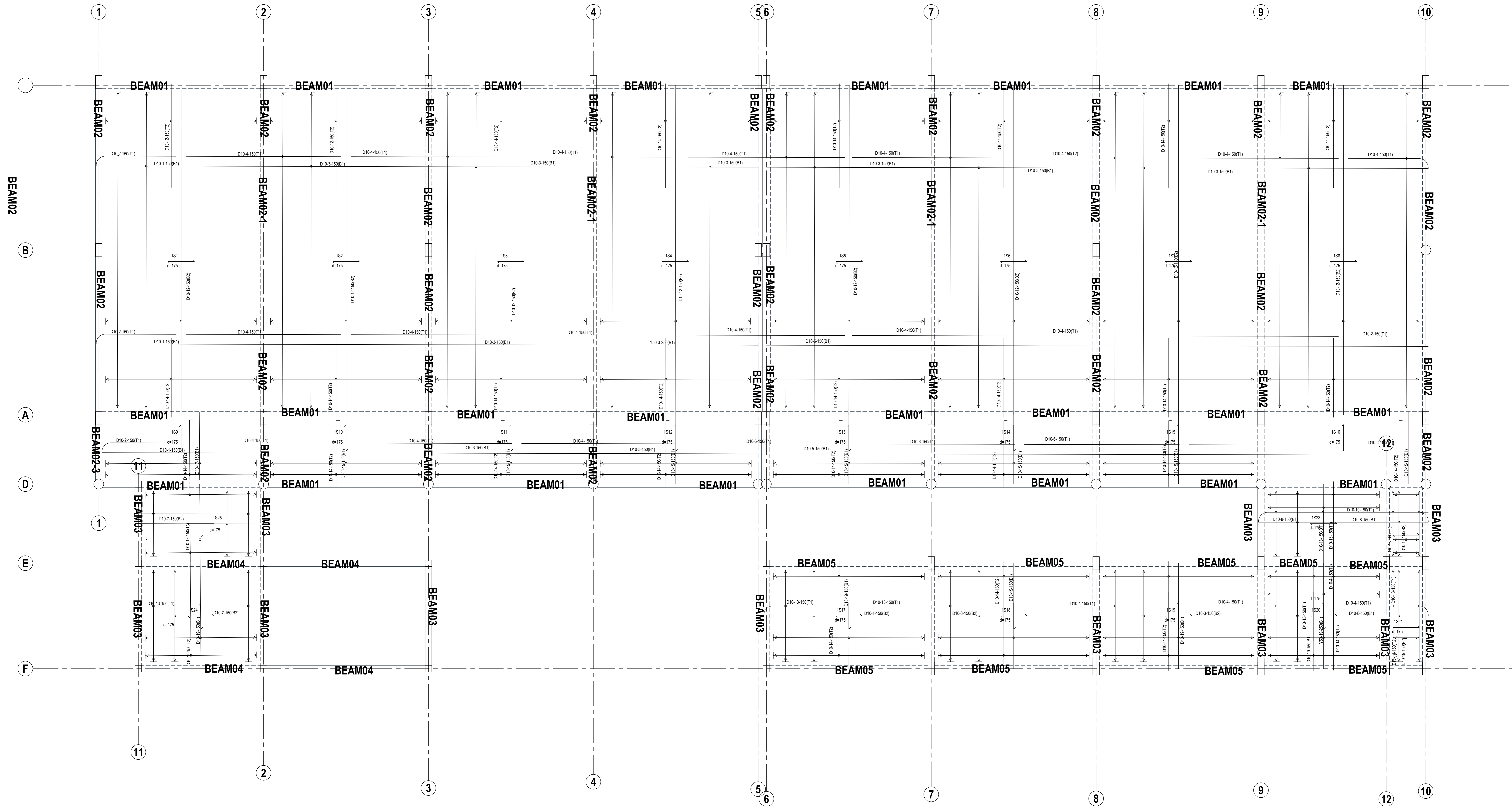

STOREY: 1 - LEVEL: +3.00m - SCALE: 1/50

Client/Agency	Project	Drawing Title	Scales	NAME	SIGNATURE	DATE	APPROVALS	CONSULTANT	
THE BOARD OF MANAGEMENT, KOMBE DAY SEC. SCHOOL	PROPOSED CONSTRUCTION OF 8 NO CLASSROOMS (DOUBLE STOREY)	SLAB DETAILS		Design	J.K.KIRWA		Name	DEPARTMENT OF TRANSPORT AND INFRASTRUCTURE State Department For Public Works P.O.Box, 87- 30300 KAPSABET For The Government of the Republic Of Kenya	
				Drawn	J.K.KIRWA		Designation		
			A	1:100	Checked	J.K.KIRWA			Signature
			B		CWO	J.K.KIRWA			Date
			C	Msc.					

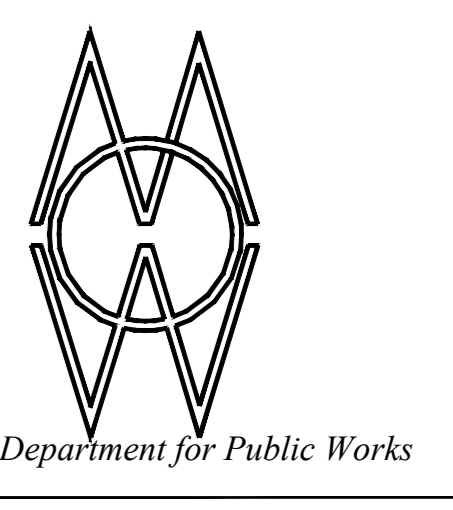

State Department for Public Works

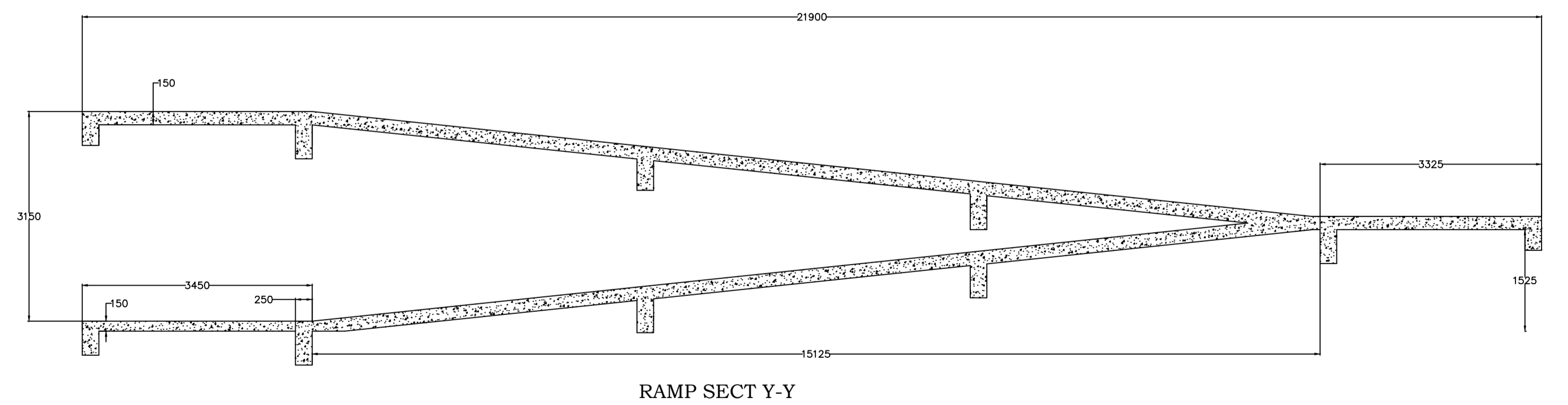
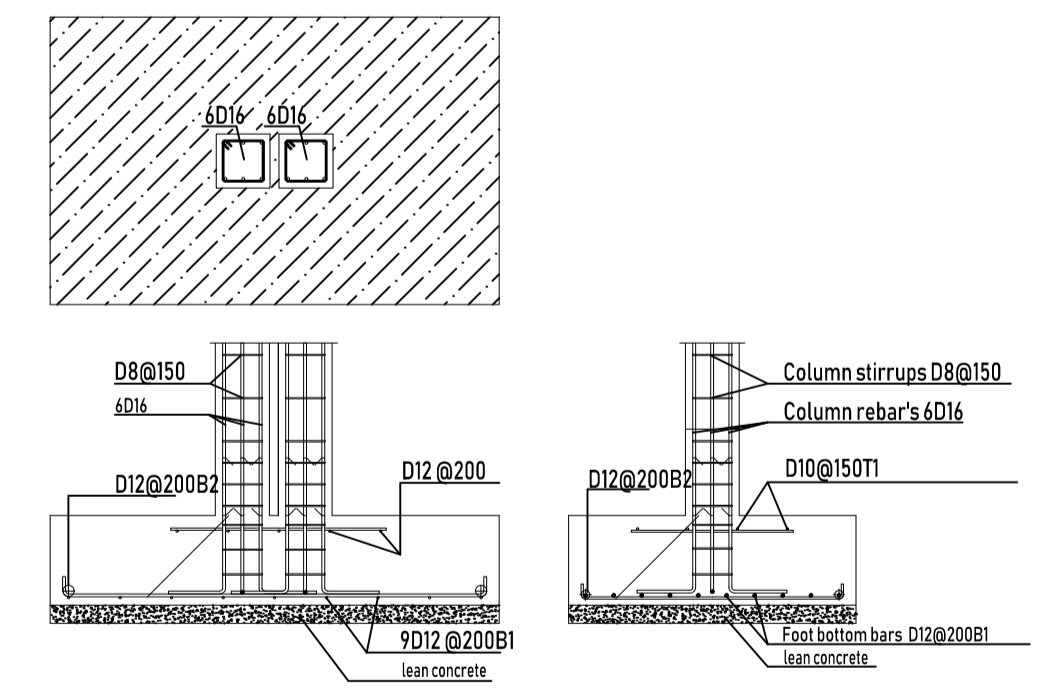
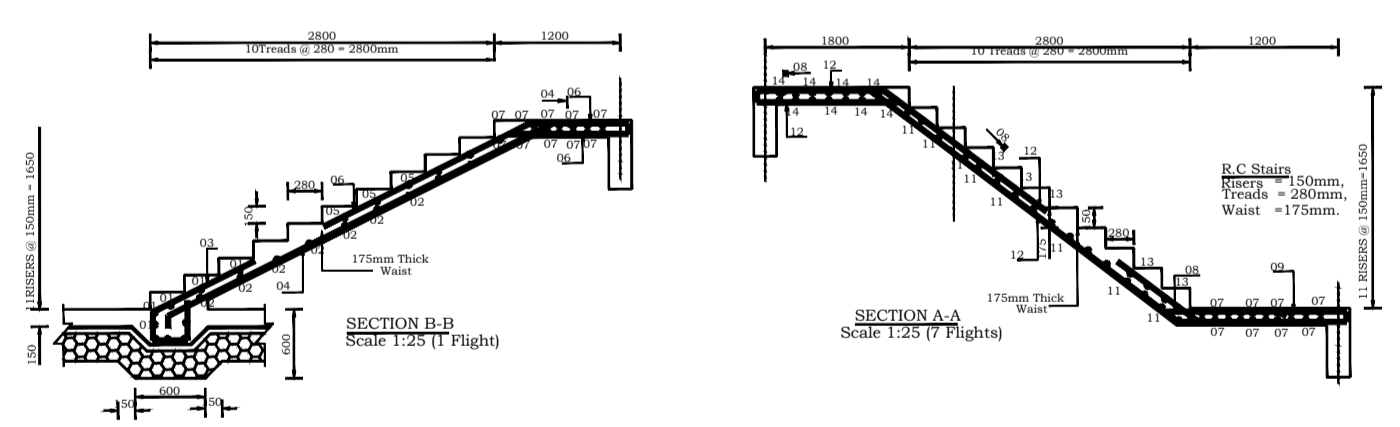
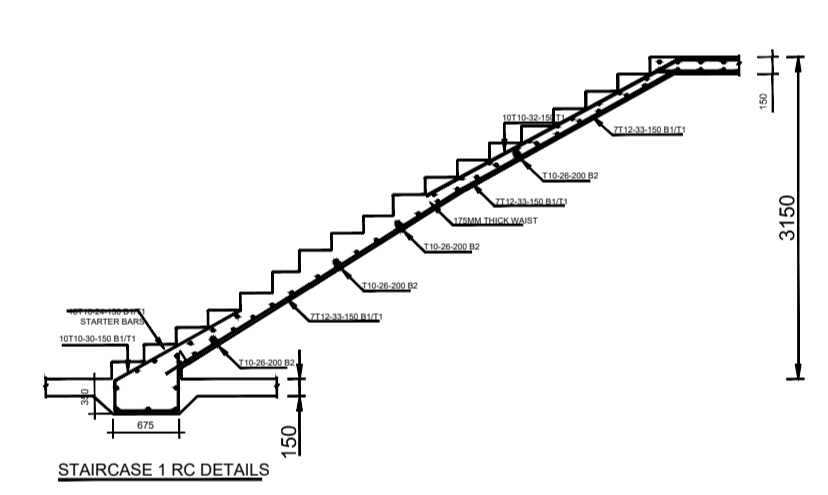
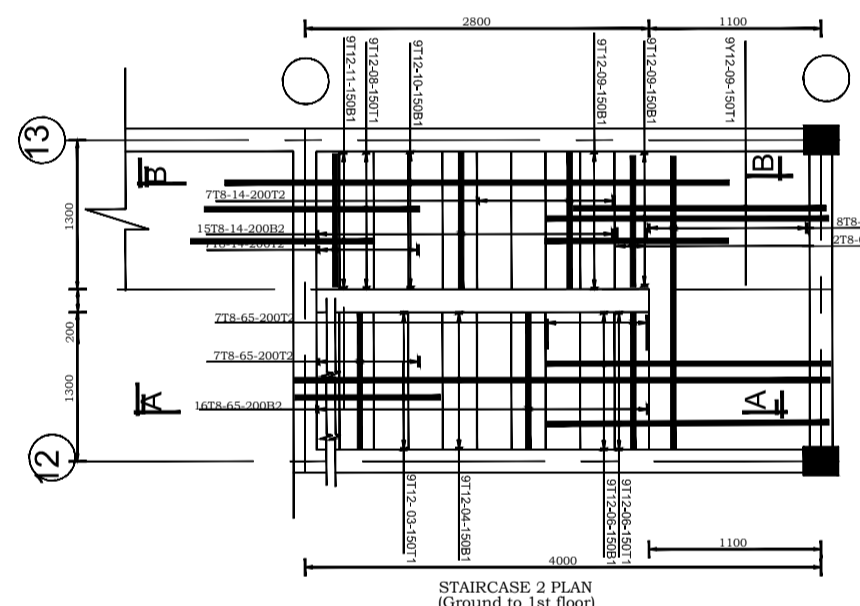
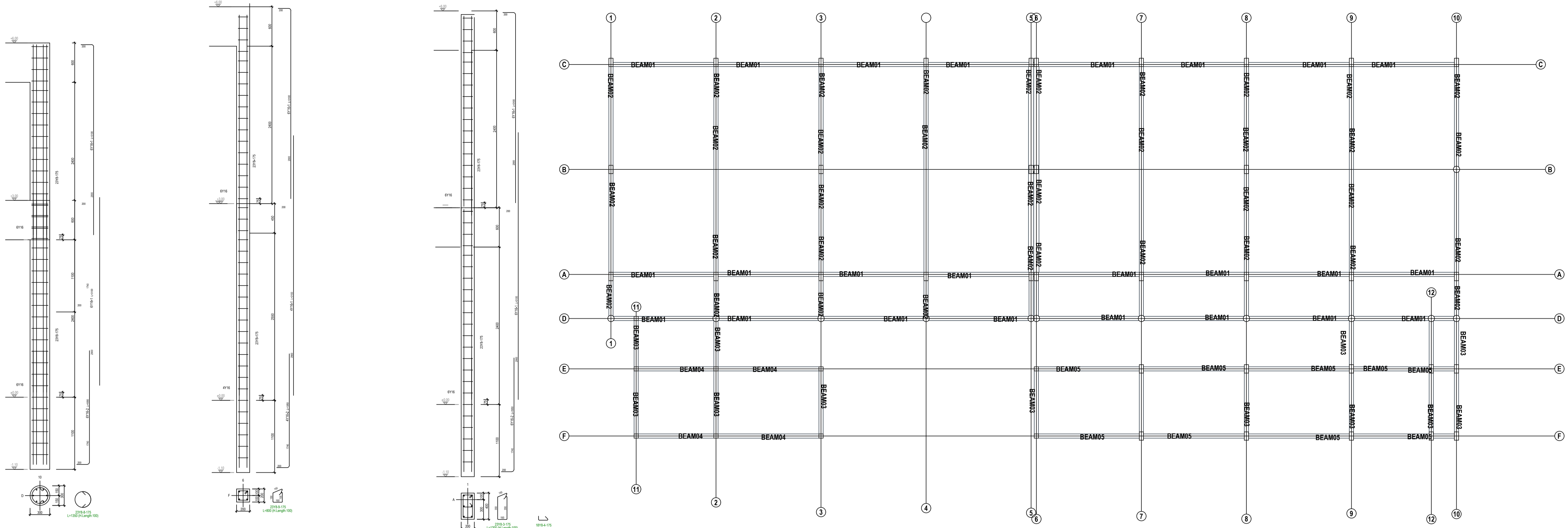

Client/Agency	Project	Drawing Title	Scales	NAME		SIGNATURE	DATE	APPROVALS		CONSULTANT
				Design	Drawn			Name	Designation	
THE BOARD OF MANAGEMENT, KOMBE DAY SEC. SCHOOL	PROPOSED CONSTRUCTION OF 8 NO CLASSROOMS (DOUBLE STOREY)	STRUCTURAL FOR BEAMS,RAMP, FOOTING&STAIRS	A 1:100	Design	J.K.KIRWA			Name		DEPARTMENT OF TRANSPORT AND INFRASTRUCTURE State Department For Public Works P.O.Box, 87- 30300 KAPSABET For The Government of the Republic Of Kenya
				Drawn	J.K.KIRWA			Designation		
				Checked	J.K.KIRWA			Signature		
				CWO	J.K.KIRWA			Date	May 2026	
			C	Msc.						

