



**NATIONAL GOVERNMENT CONSTITUENCY  
DEVELOPMENT FUND**

**CHESUMEI CONSTITUENCY**

**TENDER DOCUMENT**

**FOR  
PROPOSED CONSTRUCTION OF DIGITAL HUB AT DEPUTY COUNTY  
COMMISSIONER**

**TENDER NO. NG-CDF/CHESUMEI/DCC/001/2025-2026**

**OPEN TENDER**

**JUNE, 2026**

FUND ACCOUNT MANAGER

CHESUMEI CONSTITUENCY

NATIONAL GOVERNMENT CONSTITUENCY  
DEVELOPMENT FUND

P. O. BOX 40 – 30300 KAPSABET

# TABLE OF CONTENTS

INVITATION TO TENDER.....	V
APPENDIX TO THE PREFACE.....	vii
GUIDELINES FOR PREPARATION OF TENDER DOCUMENTS.....	vii
2. PART 1 - TENDERING PROCEDURES.....	vii
3. PART 2 - PROCUREMENT ENTITY'S REQUIREMENTS.....	vii
4. PART 3 - CONDITIONS OF CONTRACT AND CONTRACT FORMS.....	viii
INVITATION TO TENDER.....	X
<b><u>SECTION I - INSTRUCTIONS TO TENDERERS</u></b> .....	<b>1</b>
<b>A. General Provisions</b> .....	<b>1</b>
1. Scope of Tender.....	1
2. Fraud and Corruption.....	1
3. Eligible Tenderers.....	1
4. Eligible Goods, Equipment, and Services.....	3
5. Tenderer's Responsibilities.....	3
<b>B. Contents of Tender Documents</b> .....	<b>3</b>
6. Sections of Tender Document.....	3
7. Site visit.....	4
8. Pre-Tender Meeting.....	4
9. Clarification and amendment of Tender Documents.....	5
10. Amendment of Tender Documents.....	5
<b>C. Preparation of Tenders</b> .....	<b>5</b>
11. Cost of Tendering.....	5
12. Language of Tender.....	5
13. Documents Comprising the Tender.....	5
14. Form of Tender and Schedules.....	6
15. Alternative Tenders.....	6
16. Tender Prices and Discounts.....	6
17. Currencies of Tender and Payment.....	7
18. Documents Comprising the Technical Proposal.....	7
19. Documents Establishing the Eligibility and Qualifications of the Tenderer	
20. Period of Validity of Tenders.....	8
21. Tender Security.....	8
22. Format and Signing of Tender.....	9
<b>D. Sealing and Marking of Tenders</b> .....	<b>9</b>
23. Sealing and Marking of Tenders.....	9
24. Deadline for Submission of Tenders.....	10
25. Late Tenders.....	10
26. Withdrawal, Substitution, and Modification of Tenders.....	10
27. Tender Opening.....	10
<b>E. Evaluation and Comparison of Tenders</b> .....	<b>11</b>
28. Confidentiality.....	11
29. Clarification of Tenders.....	11
30. Deviations, Reservations, and Omissions.....	12
31. Determination of Responsiveness.....	12
32. Non-material Non-conformities.....	12
33. Arithmetical Errors.....	12
34. Conversion to Single Currency.....	13
35. Margin of Preference and Reservations.....	13

36.	Subcontractors.....	13
37.	Evaluation of Tenders.....	13
38.	Comparison of Tenders.....	14
39.	Abnormally Low Tenders.....	14
40.	Abnormally High Tenders.....	14
41.	Unbalanced and/or Front-Loaded Tenders.....	14
42.	Qualifications of the Tenderer.....	15
43.	Best Evaluated Tender.....	15
44.	Procuring Entity's Right to Accept Any Tender, and to Reject Any or All Tenders.....	15
<b>F.</b>	<b>Award of Contract.....</b>	<b>15</b>
45.	Award Criteria.....	15
46.	Notice of Intention to enter into a Contract.....	15
47.	Standstill Period.....	16
48.	Debriefing by the Procuring Entity.....	16
49.	Letter of Award.....	16
50.	Signing of Contract.....	16
51.	Appointment of Adjudicator.....	16
52.	Performance Security.....	16
53.	Publication of Procurement Contract.....	17
53.	Procurement Related Complaints.....	17
	<b>SECTION II-TENDER DATA SHEET(TDS).....</b>	<b>18</b>
	<b>SECTION III - EVALUATION AND QUALIFY ON CRITERIA.....</b>	<b>23</b>
1.	General Provisions.....	23
2.	Preliminary examination for Determination of Responsiveness.....	23
3.	Tender Evaluation (ITT 35).....	23
4.	Multiple Contracts.....	23
5.	Alternative Tenders (ITT 13.1).....	24
6.	Margin of Preference is not applicable.....	24
7.	Post qualification and Contract award (ITT 39), more specifically.....	24
	<b>SECTION IV – TENDERING FORMS.....</b>	<b>25</b>
	<b>QUALIFICATION FORMS.....</b>	<b>28</b>
1.	Form Equ. Equipment.....	28
2.	Form per-1.....	29
4.	FORM PER-2.....	30
5.	<b>TENDERERS QUALIFICATION WITHOUT PRE-QUALIFICATION.....</b>	<b>32</b>
	FORM ELI -1.1.....	32
	FORM ELI -1.2.....	33
	FORM CON – 2.....	34
5.4	FORM FIN – 3.1.....	36
5.5	FORM FIN – 3.2.....	37
5.6	FORM FIN – 3.3.....	38
5.7	FORM FIN – 3.4.....	38
5.8	FORM EXP - 4.1.....	39
5.9	FORM EXP - 4.2(a).....	40
5.11	FORM EXP - 4.2(b).....	41
	<b>OTHER FORMS.....</b>	<b>42</b>
6.	<b>FORM OF TENDER.....</b>	<b>42</b>
a)	TENDERER'S ELIGIBILITY- CONFIDENTIAL BUSINESS QUESTIONNAIRE.....	45
b)	CERTIFICATE OF INDEPENDENT TENDER DETERMINATION.....	48

c)	SELF-DECLARATION FORM - SELF DECLARATION OF THE TENDERER.....	49
d)	APPENDIX 1- FRAUD AND CORRUPTION.....	52
7.	FORM OF TENDER SECURITY - DEMAND BANK GUARANTEE.....	54
8.	FORM OF TENDER SECURITY (INSURANCE GUARANTEE).....	55
9.	FORM OF TENDER-SECURING DECLARATION.....	56
10.	APPENDIX TO TENDER.....	57
<b>PART II - WORK REQUIREMENTS.....</b>		<b>58</b>
SECTION V - DRAWINGS.....		58
SECTION VI - SPECIFICATIONS.....		58
SECTION VII - BILLS OF QUANTITIES.....		59
1.	Objectives.....	59
2.	Day work Schedule.....	59
3.	Provisional Sums.....	59
4.	The Bills of Quantities.....	59
<b>PART III-CONDITIONS OF CONTRACT AND CONTRACT FORMS.....</b>		<b>60</b>
SECTION VIII - GENERAL CONDITIONS OF CONTRACT.....		60
<b>A. General</b>		
1.	Definitions.....	61
2.	Interpretation.....	61
3.	Language and Law.....	62
4.	Project Manager's Decisions.....	63
5.	Delegation.....	63
6.	Communications.....	63
7.	Subcontracting.....	63
8.	Other Contractors.....	63
9.	Personnel and Equipment.....	63
10.	Procuring Entity's and Contractor's Risks.....	63
11.	Procuring Entity's Risks.....	63
12.	Contractor's Risks.....	64
13.	Insurance.....	64
14.	Site Data.....	64
15.	Contractor to Construct the Works.....	64
16.	The Works to Be Completed by the Intended Completion Date.....	64
17.	Approval by the Project Manager.....	64
18.	Safety.....	65
19.	Discoveries.....	65
20.	Possession of the Site.....	65
21.	Access to the Site.....	65
22.	Instructions, Inspections and Audits.....	65
23.	Appointment of the Adjudicator.....	65
24.	Settlement of Claims and Disputes.....	66
25.	Fraud and Corruption.....	68
<b>B. Time Control.....</b>		
1.	Program.....	68
2.	Extension of the Intended Completion Date.....	69
3.	Acceleration.....	69
4.	Delays Ordered by the Project Manager.....	69
5.	Management Meetings.....	69
6.	Early Warning.....	70

<b>C.</b>	<b>Quality Control.....</b>	<b>69</b>
1.	Identifying Defects.....	69
2.	Tests.....	69
3.	Correction of Defects.....	69
4.	Uncorrected Defects.....	69
<b>D.</b>	<b>Cost Control.....</b>	<b>70</b>
1.	Contract Price.....	70
2.	Changes in the Contract Price.....	70
3.	Variations.....	71
4.	Cash Flow Forecasts.....	72
5.	Payment Certificates.....	72
6.	Payments.....	72
7.	Compensation Events.....	73
8.	Tax.....	73
9.	Currency of Payment.....	73
10.	Price Adjustment.....	73
11.	Retention.....	74
12.	Liquidated Damages.....	74
13.	Bonus.....	74
14.	Advance Payment.....	74
15.	Securities.....	75
16.	Dayworks.....	75
17.	Cost of Repairs.....	75
<b>E.</b>	<b>Finishing the Contract.....</b>	<b>75</b>
1.	Completion.....	75
2.	Taking Over.....	75
3.	Final Account.....	75
4.	Operating and Maintenance Manuals.....	75
5.	Termination.....	76
6.	Payment upon Termination.....	76
7.	Property.....	76
8.	Release from Performance.....	76
	<b>SECTION IX - SPECIAL CONDITIONS OF CONTRACT.....</b>	<b>77</b>
	<b>SECTION X - CONTRACT FORMS.....</b>	<b>88</b>
	FORM No. 1 - NOTIFICATION OF INTENTION TO AWARD.....	80
	FORM No. 2 – REQUEST FOR REVIEW.....	83
	FORM No. 3 - LETTER OF AWARD.....	83
	FORM No. 4 - CONTRACT AGREEMENT.....	84
	FORM No. 5 - PERFORMANCE SECURITY [Option 1 - Unconditional Demand Bank Guarantee].....	85
	FORM No. 6- PERFORMANCE SECURITY [Option 2– Performance Bond].....	86
	FORM No. 7- ADVANCE PAYMENT SECURITY.....	88
	FORM No. 8- RETENTION MONEY SECURITY.....	87
	FORM No. 9- BENEFICIAL OWNERSHIP DISCLOSURE FORM.....	87

# INVITATION TO TENDER

NG-CDF CHESUMEI CONSTITUENCY,  
P.O. Box 40-30300,  
KAPSABET.

**TENDER NO. NG-CDF/CHESUMEI/DCC/001/2025-2026**

**TENDER NAME: Proposed Construction of Digital Hub at Deputy County Commissioner Office-Chesumei Office**  
The National Government Constituency Development Fund-Chesumei Constituency invites bids from eligible bidders for Proposed Construction of Digital Hub at Deputy County Commissioner Office-Chesumei Office.

1. This Tender is **Open**
2. Qualified and interested tenderers may obtain further information and inspect the Tender Documents at NG-CDF Offices, Chesumei Constituency during office hours [0900 to 1500 hours] at the address given below.
3. A complete set of tender documents may be downloaded from the Chesumei NG-CDF website [www.tenders.go.ke](http://www.tenders.go.ke).
4. Tender documents may be obtained electronically from [www.tenders.go.ke](http://www.tenders.go.ke). Tender documents obtained electronically will be free of charge.
5. Tender documents may be viewed and downloaded for free from the website [www.tenders.go.ke](http://www.tenders.go.ke).
6. Tenders shall be quoted in Kenya Shillings and shall include all taxes. Tenders shall remain valid for 259 days from the date of opening of tenders.
7. This tender must be accompanied by a **Tender securing declaration form**
8. The Tenderer MUST chronologically serialize all pages of the tender documents submitted in the order of 1,2,3, 4, ...
9. Completed tenders must be delivered to the address below so as to be received on or before **29<sup>th</sup> June, 2026 at 2:00 P.M.** Bids submitted after this prescribed time shall be rejected.
10. Tenders will be opened immediately after the deadline date and time specified above or any deadline date and time specified later. Tenders will be publicly opened in the presence of the Tenderers' designated representatives who choose to attend at the address below.
11. Late tenders will be rejected

The address referred to above are:

## A. Address for obtaining further information and for purchasing tender documents

Fund Account Manager,  
National Government Constituency Development Fund,  
Chesumei Constituency,  
P.O. Box 40-30300, Kapsabet.

**B. Address for Submission of Tenders. (Office or Tender Box)**

Physical address for hand Courier Delivery to office or Tender Box

Fund Account Manager,  
National Government Constituency Development Fund,  
Chesumei Constituency,  
P.O. Box 40-30300,  
Kapsabet.

**C. Address for Opening of Tenders.**

Fund Account Manager,  
National Government Constituency Development Fund,  
Chesumei Constituency,  
P.O. Box 40-30300,  
Kapsabet.

---

# **PART 1 - TENDERING PROCEDURES**

---

## SECTION I: INSTRUCTIONS TO TENDERERS

### A General Provisions

#### 1. Scope of Tender

- 1.1 The Procuring Entity as defined in the Appendix to Conditions of Contract invites tenders for Works Contract as described in the tender documents. The name, identification, and number of lots (contracts) of this Tender Document are **specified in the TDS**.

#### 2. Fraud and Corruption

- 2.1 The Procuring Entity requires compliance with the provisions of the Public Procurement and Asset Disposal Act, 2015, Section 62 “Declaration not to engage in corruption”. The tender submitted by a person shall include a declaration that the person shall not engage in any corrupt or fraudulent practice and a declaration that the person or his or her sub-contractors are not debarred from participating in public procurement proceedings.
- 2.2 The Procuring Entity requires compliance with the provisions of the Competition Act 2010, regarding collusive practices in contracting. Any tenderer found to have engaged in collusive conduct shall be disqualified and criminal and/or civil sanctions may be imposed. To this effect, Tenders shall be required to complete and sign the “Certificate of Independent Tender Determination” annexed to the Form of Tender.
- 2.3 Unfair Competitive Advantage - Fairness and transparency in the tender process require that the firms or their Affiliates competing for a specific assignment do not derive a competitive advantage from having provided consulting services related to this tender. To that end, the Procuring Entity shall indicate in the **Data Sheet** and make available to all the firms together with this tender document all information that would in that respect give such firm any unfair competitive advantage over competing firms.
- 2.4 Unfair Competitive Advantage -Fairness and transparency in the tender process require that the Firms or their Affiliates competing for a specific assignment do not derive a competitive advantage from having provided consulting services related to this tender being tendered for. The Procuring Entity shall indicate in the **TDS** firms (if any) that provided consulting services for the contract being tendered for. The Procuring Entity shall check whether the owners or controllers of the Tenderer are same as those that provided consulting services. The Procuring Entity shall, upon request, make available to any tenderer information that would give such firm unfair competitive advantage over competing firms.

#### 3. Eligible Tenderers

- 3.1 A Tenderer may be a firm that is a private entity, a state-owned enterprise or institution subject to ITT 3.7 or any combination of such entities in the form of a joint venture (JV) under an existing agreement or with the intent to enter into such an agreement supported by a letter of intent. Public employees and their close relatives (*wives, children, brothers, sisters and uncles and aunts*) are not eligible to participate in the tender. In the case of a joint venture, all members shall be jointly and severally liable for the execution of the entire Contract in accordance with the Contract terms. The JV shall nominate a Representative who shall have the authority to conduct all business for and on behalf of any and all the members of the JV during the tendering process and, in the event the JV is awarded the Contract, during contract execution. The maximum number of JV members shall be specified in the **TDS**.
- 3.2 Public Officers of the Procuring Entity, their Spouses, Child, Parent, Brothers or Sister. Child, Parent, Brother or Sister of a Spouse, their business associates or agents and firms/organizations in which they have a substantial or controlling interest shall not be eligible to tender or be awarded a contract. Public Officers are also not allowed to participate in any procurement proceedings.
- 3.3 A Tenderer shall not have a conflict of interest. Any tenderer found to have a conflict of interest shall be disqualified. A tenderer may be considered to have a conflict of interest for the purpose of this tendering process, if the tenderer:
- Directly or indirectly controls, is controlled by or is under common control with another tenderer; or
  - Receives or has received any direct or indirect subsidy from another tenderer; or
  - Has the same legal representative as another tenderer; or
  - Has a relationship with another tenderer, directly or through common third parties, that puts it in a position

to influence the tender of another tenderer, or influence the decisions of the Procuring Entity regarding this tendering process; or

- e) Any of its affiliates participated as a consultant in the preparation of the design or technical specifications of the works that are the subject of the tender; or
- f) any of its affiliates has been hired (or is proposed to be hired) by the Procuring Entity as Engineer for the Contract implementation; or
- g) Would be providing goods, works, or non-consulting services resulting from or directly related to consulting services for the preparation or implementation of the contract specified in this Tender Document or
- h) Has a close business or family relationship with a professional staff of the Procuring Entity who:
  - i) are directly or indirectly involved in the preparation of the Tender document or specifications of the Contract, and/or the Tender evaluation process of such contract; or
  - ii) would be involved in the implementation or supervision of such Contract unless the conflict stemming from such relationship has been resolved in a manner acceptable to the Procuring Entity throughout the tendering process and execution of the Contract.

3.4A tenderer shall not be involved in corrupt, coercive, obstructive, collusive or fraudulent practice.

A tenderer that is proven to have been involved any of these practices shall be automatically disqualified.

3.5A Tenderer (either individually or as a JV member) shall not participate in more than one Tender, except for permitted alternative tenders. This includes participation as a subcontractor in other Tenders. Such participation shall result in the disqualification of all Tenders in which the firm is involved. A firm that is not a tenderer or a JV member may participate as a subcontractor in more than one tender. Members of a joint venture may not also make an individual tender, be a subcontractor in a separate tender or be part of another joint venture for the purposes of the same Tender.

3.6A Tenderer may have the nationality of any country, subject to the restrictions pursuant to ITT 4.8. A Tenderer shall be deemed to have the nationality of a country if the Tenderer is constituted, incorporated or registered in and operates in conformity with the provisions of the laws of that country, as evidenced by its articles of incorporation (or equivalent documents of constitution or association) and its registration documents, as the case may be. This criterion also shall apply to the determination of the nationality of proposed subcontractors or sub-consultants for any part of the Contract including related Services.

3.7 Tenderer that has been debarred from participating in public procurement shall be ineligible to tender or be awarded a contract. The list of debarred firms and individuals is available from the website of PPRA [www.ppra.go.ke](http://www.ppra.go.ke).

3.8 Tenderers that are state-owned enterprises or institutions may be eligible to compete and be awarded a Contract(s) only if they are accredited by PPRA to be (i) a legal public entity of the state Government and/or public administration, (ii) financially autonomous and not receiving any significant subsidies or budget support from any public entity or Government, and (iii) operating under commercial law and vested with legal rights and liabilities similar to any commercial enterprise to enable it compete with firms in the private sector on an equal basis.

3.9A Firms and individuals may be ineligible if their countries of origin (a) as a matter of law or official regulations, Kenya prohibits commercial relations with that country, or (b) by an act of compliance with a decision of the United Nations Security Council taken under Chapter VII of the Charter of the United Nations, Kenya prohibits any import of goods or contracting of works or services from that country, or any payments to any country, person, or entity in that country. A tenderer shall provide such documentary evidence of eligibility satisfactory to the Procuring Entity, as the Procuring Entity shall reasonably request.

3.10 Foreign tenderers are required to source at least forty (40%) percent of their contract inputs (in supplies, subcontracts and labor) from national suppliers and contractors. To this end, a foreign tenderer shall provide in its tender documentary evidence that this requirement is met. Foreign tenderers not meeting this criterion will be automatically disqualified. Information required to enable the Procuring Entity determine if this condition is met shall be provided in for this purpose is provided in “SECTION III - EVALUATION AND QUALIFICATION CRITERIA, Item 9”.

3.11 Pursuant to the eligibility requirements of ITT 4.10, a tender is considered a foreign tenderer, if the tenderer is not registered in Kenya or if the tenderer is registered in Kenya and has less than 51 percent ~~ownership~~ ownership by

Citizens. JVs are considered as foreign tenderers if the individual member firms are not registered in Kenya or if are registered in Kenya and have less than 51 percent ownership by Kenyan citizens. The JV shall not subcontract to foreign firms more than 10 percent of the contract price, excluding provisional sums.

3.12 The National Construction Authority Act of Kenya requires that all local and foreign contractors be registered with the National Construction Authority and be issued with a Registration Certificate before they can undertake any construction works in Kenya. Registration shall not be a condition for tender, but it shall be a condition of contract award and signature. A selected tenderer shall be given opportunity to register before such award and signature of contract. Application for registration with National Construction Authority may be accessed from the website [www.nca.go.ke](http://www.nca.go.ke).

3.13 The Competition Act of Kenya requires that firms wishing to tender as Joint Venture undertakings which may prevent, distort or lessen competition in provision of services are prohibited unless they are exempt in accordance with the provisions of Section 25 of the Competition Act, 2010. JVs will be required to seek for exemption from the Competition Authority. Exemption shall not be a condition for tender, but it shall be a condition of contract award and signature. A JV tenderer shall be given opportunity to seek such exemption as a condition of award and signature of contract. Application for exemption from the Competition Authority of Kenya may be accessed from the website [www.cak.go.ke](http://www.cak.go.ke)

3.14 A Kenyan tenderer shall provide evidence of having fulfilled his/her tax obligations by producing a valid tax clearance certificate or tax exemption certificate issued by the Kenya Revenue Authority.

#### **4. Eligible Goods, Equipment, and Services**

4.1 Goods, equipment and services to be supplied under the Contract may have their origin in any country that is not eligible under ITT 3.9. At the Procuring Entity's request, Tenderers may be required to provide evidence of the origin of Goods, equipment and services.

4.2 Any goods, works and production processes with characteristics that have been declared by the relevant national environmental protection agency or by other competent authority as harmful to human beings and to the environment shall not be eligible for procurement.

#### **5. Tenderer's Responsibilities**

5.1 The tenderer shall bear all costs associated with the preparation and submission of his/her tender, and the Procuring Entity will in no case be responsible or liable for those costs.

5.2 The tenderer, at the tenderer's own responsibility and risk, is encouraged to visit and examine the Site of the Works and its surroundings, and obtain all information that may be necessary for preparing the tender and entering into a contract for construction of the Works. The costs of visiting the Site shall be at the tenderer's own expense.

5.3 The Tenderer and any of its personnel or agents will be granted permission by the Procuring Entity to enter upon its premises and lands for the purpose of such visit. The Tenderer shall indemnify the Procuring Entity against all liability arising from death or personal injury, loss of or damage to property, and any other losses and expenses incurred as a result of the inspection.

5.4 The tenderer shall provide in the Form of Tender and Qualification Information, a preliminary description of the proposed work method and schedule, including charts, as necessary or required.

#### **B. Contents of Tender Documents**

#### **6. Sections of Tender Document**

6.1 The tender document consists of Parts 1, 2, and 3, which includes all the sections specified below, and which should be read in conjunction with any Addenda issued in accordance with ITT 8.

## **PART 1 Tendering Procedures**

- i) Section I - Instructions to Tenderers (ITT)
- ii) Section II - Tender Data Sheet (TDS)
- iii) Section III - Evaluation and Qualification Criteria
- iv) Section IV - Tendering Forms

## **PART 2 Works Requirements**

- i) Section V - Drawings
- ii) Section VI - Specifications
- iii) Section VII - Bills of Quantities

## **PART 3 Conditions of Contract and Contract Forms**

- i) Section VIII - General Conditions of Contract (GCC)
- ii) Section IX - Special Conditions of Contract (SC)
- iii) Section X - Contract Forms

6.2 The Invitation to Tender Document (ITT) issued by the Procuring Entity is not part of the Contract documents.

6.3 Unless obtained directly from the Procuring Entity, the Procuring Entity is not responsible for the completeness of the Tender document, responses to requests for clarification, the minutes of the pre-Tender meeting (if any), or Addenda to the Tender document in accordance with ITT 8. In case of any contradiction, documents obtained directly from the Procuring Entity shall prevail.

The Tenderer is expected to examine all instructions, forms, terms, and specifications in the Tender Document and to furnish with its Tender all information and documentation as is required by the Tender document.

## **7. Site Visit**

7.1 The Tenderer, at the Tenderer's own responsibility and risk, is encouraged to visit and examine and inspect the Site of the Required Services and its surroundings and obtain all information that may be necessary for preparing the Tender and entering into a contract for the Services. The costs of visiting the Site shall be at the Tenderer's own expense.

## **8. Pre-Tender Meeting**

8.1 The Procuring Entity shall specify in the **TDS** if a pre-tender meeting will be held, when and where. The Procuring Entity shall also specify in the **TDS** if a pre-arranged pretender site visit will be held and when. The Tenderer's designated representative is invited to attend a pre-arranged pretender visit of the site of the works. The purpose of the meeting will be to clarify issues and to answer questions on any matter that may be raised at that stage.

8.2 The Tenderer is requested to submit any questions in writing, to reach the Procuring Entity not later than the period specified in the **TDS** before the meeting.

8.3 Minutes of the pre-Tender meeting and the pre-arranged pretender site visit of the site of the works, if applicable, including the text of the questions asked by Tenderers and the responses given, together with any responses prepared after the meeting, will be transmitted promptly to all Tenderers who have acquired the Tender Documents in accordance with ITT 6.3. Minutes shall not identify the source of the questions asked.

8.4 The Procuring Entity shall also promptly publish anonymized (*nonames*) Minutes of the pre-Tender meeting and the pre-arranged pretender visit of the site of the works at the web page identified in the **TDS**. Any modification to the Tender Documents that may become necessary as a result of the pre-tender meeting and the pre-arranged pretender site visit, shall be made by the Procuring Entity exclusively through the issue of an Addendum pursuant to ITT 8 and not through the minutes of the pre-Tender meeting. Nonattendance at the pre-Tender meeting will not be a cause for disqualification of a Tenderer.

## **9. Clarification and amendments of Tender Documents**

9.1 A Tenderer requiring any clarification of the Tender Document shall contact the Procuring Entity in writing at the Procuring Entity's address specified in the **TDS** or raise its enquiries during the pre-Tender meeting and the pre-

arranged pretender visit of the site of the works if provided for in accordance with ITT 8.4. The Procuring Entity will respond in writing to any request for clarification, provided that such request is received no later than the period specified in the **TDS** prior to the deadline for submission of tenders. The Procuring Entity shall forward copies of its response to all tenderers who have acquired the Tender Documents in accordance with ITT 6.3, including a description of the inquiry but without identifying its source. If specified in the **TDS**, the Procuring Entity shall also promptly publish its response at the web page identified in the **TDS**. Should the clarification result in changes to the essential elements of the Tender Documents, the Procuring Entity shall amend the Tender Documents appropriately following the procedure under ITT 8.4.

## **10. Amendment of Tendering Document**

- 10.1 At any time prior to the deadline for submission of Tenders, the Procuring Entity may amend the Tendering document by issuing addenda.
- 10.2 Any addendum issued shall be part of the tendering document and shall be communicated in writing to all who have obtained the tendering document from the Procuring Entity in accordance with ITT 6.3. The Procuring Entity shall also promptly publish the addendum on the Procuring Entity's web page in accordance with ITT 8.4.
- 10.3 To give prospective Tenderers reasonable time in which to take an addendum into account in preparing their Tenders, the Procuring Entity shall extend, as necessary, the deadline for submission of Tenders, in accordance with ITT 25.2 below.

## **C. Preparation of Tenders**

### **11. Cost of Tendering**

- 11.1 The Tenderer shall bear all costs associated with the preparation and submission of its Tender, and the Procuring Entity shall not be responsible or liable for those costs, regardless of the conduct or outcome of the tendering process.

### **12. Language of Tender**

- 12.1 The Tender, as well as all correspondence and documents relating to the tender exchanged by the tenderer and the Procuring Entity, shall be written in the English Language. Supporting documents and printed literature that are part of the Tender may be in another language provided they are accompanied by an accurate and notarized translation of the relevant passages into the English Language, in which case, for purposes of interpretation of the Tender, such translation shall govern.

### **13. Documents Comprising the Tender**

- 13.1 The Tender shall comprise the following:
- a) Form of Tender prepared in accordance with ITT 14;
  - b) Schedules including priced Bill of Quantities, completed in accordance with ITT 14 and ITT 16;
  - c) Tender Security or Tender-Securing Declaration, in accordance with ITT 21.1;
  - d) Alternative Tender, if permissible, in accordance with ITT 15;
  - e) Authorization: written confirmation authorizing the signatory of the Tender to commit the Tenderer, in accordance with ITT 22.3;
  - f) Qualifications: documentary evidence in accordance with ITT 19 establishing the Tenderer's qualifications to perform the Contract if its Tender is accepted;
  - g) Conformity: a technical proposal in accordance with ITT 18;
  - h) Any other document required in the **TDS**.
- 13.2 In addition to the requirements under ITT 11.1, Tenders submitted by a JV shall include a copy of the Joint Venture Agreement entered into by all members. Alternatively, a letter of intent to execute a Joint Venture Agreement in the event of a successful Tender shall be signed by all members and submitted with the Tender,

together with a copy of the proposed Agreement. The Tenderer shall chronologically serialize pages of all tender documents submitted.

13.3 The Tenderer shall furnish in the Form of Tender information on commissions and gratuities, if any, paid or to be paid to agents or any other party relating to this Tender.

#### **14. Form of Tender and Schedules**

14.1 The Form of Tender and Schedules, including the Bill of Quantities, shall be prepared using the relevant forms furnished in Section IV, Tendering Forms. The forms must be completed without any alterations to the text, and no substitutes shall be accepted except as provided under ITT 20.3. All blank spaces shall be filled in with the information requested.

#### **15. Alternative Tenders**

15.1 Unless otherwise specified in the TDS, alternative Tenders shall not be considered.

15.2 When alternative times for completion are explicitly invited, a statement to that effect will be included in the TDS, and the method of evaluating different alternative times for completion will be described in Section III, Evaluation and Qualification Criteria.

15.3 Except as provided under ITT 13.4 below, Tenderers wishing to offer technical alternatives to the requirements of the Tender Documents must first price the Procuring Entity's design as described in the Tender Documents and shall further provide all information necessary for a complete evaluation of the alternative by the Procuring Entity, including drawings, design calculations, technical specifications, breakdown of prices, and proposed construction methodology and other relevant details. Only the technical alternatives, if any, of the Tenderer with the Winning Tender conforming to the basic technical requirements shall be considered by the Procuring Entity. When specified in the TDS, Tenderers are permitted to submit alternative technical solutions for specified parts of the Works, and such parts will be identified in the TDS, as will the method for their evaluating, and described in Section VII, Works' Requirements.

#### **16. Tender Prices and Discounts**

16.1 The prices and discounts (including any price reduction) quoted by the Tenderer in the Form of Tender and in the Bill of Quantities shall conform to the requirements specified below.

16.2 The Tenderer shall fill in rates and prices for all items of the Works described in the Bill of Quantities. Items against which no rate or price is entered by the Tenderer shall be deemed covered by the rates for other items in the Bill of Quantities and will not be paid for separately by the Procuring Entity. An item not listed in the priced Bill of Quantities shall be assumed to be not included in the Tender, and provided that the Tender is determined substantially responsive notwithstanding this omission, the average price of the item quoted by substantially responsive Tenderers will be added to the Tender price and the equivalent total cost of the Tender so determined will be used for price comparison.

16.3 The price to be quoted in the Form of Tender, in accordance with ITT 14.1, shall be the total price of the Tender, including any discounts offered.

16.4 The Tenderer shall quote any discounts and the methodology for their application in the Form of Tender, in accordance with ITT 14.1.

16.5 It will be specified in the TDS if the rates and prices quoted by the Tenderer are or are not subject to adjustment during the performance of the Contract in accordance with the provisions of the Conditions of Contract, except in cases where the contract is subject to fluctuations and adjustments, not fixed price. In such a case, the Tenderer shall furnish the indices and weightings for the price adjustment formulae in the Schedule of Adjustment Data and the Procuring Entity may require the Tenderer to justify its proposed indices and weightings.

16.6 Where tenders are being invited for individual lots (contracts) or for any combination of lots (packages), tenderers wishing to offer discounts for the award of more than one Contract shall specify in their Tender the price reductions applicable to each package, or alternatively, to individual Contracts within the package. Discounts shall be submitted in accordance with ITT 16.4, provided the Tenders for all lots (contracts) are opened at the same time.

16.7 All duties, taxes, and other levies payable by the Contractor under the Contract, or for any other cause, as of the date 30 days prior to the deadline for submission of Tenders, shall be included in the rates and prices and the total Tender Price submitted by the Tenderer.

## **17. Currencies of Tender and Payment**

17.1 Tenderers shall quote entirely in Kenya Shillings. The unit rates and the prices shall be quoted by the Tenderer in the Bill of Quantities, entirely in Kenya shillings. A Tenderer expecting to incur expenditures in other currencies for inputs to the Works supplied from outside Kenya shall devise own ways of getting foreign currency to meet those expenditures.

## **18. Documents Comprising the Technical Proposal**

18.1 The Tenderer shall furnish a technical proposal including a statement of work methods, equipment, personnel, schedule and any other information as stipulated in Section IV, Tender Forms, in sufficient detail to demonstrate the adequacy of the Tenderer's proposal to meet the work's requirements and the completion time.

## **19. Documents Establishing the Eligibility and Qualifications of the Tenderer**

19.1 Tenderers shall complete the Form of Tender, included in Section IV, Tender Forms, to establish Tenderer's eligibility in accordance with ITT 4.

19.2 In accordance with Section III, Evaluation and Qualification Criteria, to establish its qualifications to perform the Contract the Tenderer shall provide the information requested in the corresponding information sheets included in Section IV, Tender Forms.

19.3 A margin of preference will not be allowed. Preference and reservations will be allowed, individually or in joint ventures. Applying for eligibility for Preference and reservations shall supply all information required to satisfy the criteria for eligibility specified in accordance with ITT 33.1.

19.4 Tenderers shall be asked to provide, as part of the data for qualification, such information, including details of ownership, as shall be required to determine whether, according to the classification established by the Procuring Entity, a contractor or group of contractors qualifies for a margin of preference. Further the information will enable the Procuring Entity identify any actual or potential conflict of interest in relation to the procurement and/or contract management processes, or a possibility of collusion between tenderers, and thereby help to prevent any corrupt influence in relation to the procurement process or contract management.

19.5 The purpose of the information described in ITT 19.4 above overrides any claims to confidentiality which a tenderer may have. There can be no circumstances in which it would be justified for a tenderer to keep information relating to its ownership and control confidential where it is tendering to undertake public sector work and receive public sector funds. Thus, confidentiality will not be accepted by the Procuring Entity as a justification for a Tenderer's failure to disclose, or failure to provide required information on its ownership and control.

19.6 The Tenderer shall provide further documentary proof, information or authorizations that the Procuring Entity may request in relation to ownership and control which information on any changes to the information which was provided by the tenderer under ITT 6.3. The obligations to require this information shall continue for the duration of the procurement process and contract performance and after completion of the contract, if any change to the information previously provided may reveal a conflict of interest in relation to the award or management of the contract.

19.7 All information provided by the tenderer pursuant to these requirements must be complete, current and accurate as at the date of provision to the Procuring Entity. In submitting the information required pursuant to these requirements, the Tenderer shall warrant that the information submitted is complete, current and accurate as at the date of submission to the Procuring Entity.

19.8 If a tenderer fails to submit the information required by these requirements, its tender will be rejected. Similarly, if the Procuring Entity is unable, after taking reasonable steps, to verify to a reasonable degree the information submitted by a tenderer pursuant to these requirements, then the tender will be rejected.

19.9 If information submitted by a tenderer pursuant to these requirements, or obtained by the Procuring Entity (whether through its own enquiries, through notification by the public or otherwise), shows any conflict of

interest which could materially and improperly benefit the tenderer in relation to the procurement or contract management process, then:

- i) if the procurement process is still ongoing, the tenderer will be disqualified from the procurement process,
- ii) if the contract has been awarded to that tenderer, the contract award will be set aside,
- iii) the tenderer will be referred to the relevant law enforcement authorities for investigation of whether the tenderer or any other persons have committed any criminal offence.

19.10 If a tenderer submits information pursuant to these requirements that is incomplete, inaccurate or out-of-date, or attempts to obstruct the verification process, then the consequences ITT 6.7 will ensue unless the tenderer can show to the reasonable satisfaction of the Procuring Entity that any such act was not material, or was due to genuine error which was not attributable to the intentional act, negligence or recklessness of the tenderer.

## 20. Period of Validity of Tenders

20.1 Tenders shall remain valid for the Tender Validity period specified in the **TDS**. The Tender Validity period starts from the date fixed for the Tender submission deadline (as prescribed by the Procuring Entity in accordance with ITT 24). A Tender valid for a shorter period shall be rejected by the Procuring Entity as non-responsive.

20.2 In exceptional circumstances, prior to the expiration of the Tender validity period, the Procuring Entity may request Tenderers to extend the period of validity of their Tenders. The request and the responses shall be made in writing. If a Tender Security is requested in accordance with ITT 21.1, it shall also be extended for thirty (30) days beyond the deadline of the extended validity period. A Tenderer may refuse the request without forfeiting its Tender security. A Tenderer granting the request shall not be required or permitted to modify its Tender, except as provided in ITT 20.3.

20.3 If the award is delayed by a period exceeding the number of days to be specified in the **TDS** days beyond the expiry of the initial tender validity period, the Contract price shall be determined as follows:

- a) in the case of **fixed price** contracts, the Contract price shall be the tender price adjusted by the factor specified in the **TDS**;
- b) in the case of **adjustable price** contracts, no adjustment shall be made; or in any case, tender evaluation shall be based on the tender price without taking into consideration the applicable correction from those indicated above.

## 21. Tender Security

21.1 The Tenderer shall furnish as part of its Tender, either a Tender-Securing Declaration or a Tender Security as specified in the **TDS**, in original form and, in the case of a Tender Security, in the amount and currency specified in the **TDS**. A Tender-Securing Declaration shall use the form included in Section IV, Tender Forms.

21.2 If a Tender Security is specified pursuant to ITT 19.1, the Tender Security shall be a demand guarantee in any of the following forms at the Tenderer's option:

- a) an unconditional Bank Guarantee issued by reputable commercial bank); or
- b) an irrevocable letter of credit;
- c) a Banker's cheque issued by a reputable commercial bank; or
- d) another security specified in the **TDS**,

21.3 If an unconditional bank guarantee is issued by a bank located outside Kenya, the issuing bank shall have a correspondent bank located in Kenya to make it enforceable. The Tender Security shall be valid for thirty (30) days beyond the original validity period of the Tender, or beyond any period of extension if requested under ITT 20.2.

21.4 If a Tender Security or Tender-Securing Declaration is specified pursuant to ITT 19.1, any Tender not accompanied by a substantially responsive Tender Security or Tender-Securing Declaration shall be rejected by the Procuring Entity as non-responsive.

21.5 If a Tender Security is specified pursuant to ITT 21.1, the Tender Security of unsuccessful Tenderers shall be returned as promptly as possible upon the successful Tenderer's signing the Contract and furnishing the Performance Security and any other documents required in the **TDS**. The Procuring Entity shall also promptly return the tender security to the tenderers where the procurement proceedings are terminated, all tenders were

determined nonresponsive or a bidder declines to extend tender validity period.

21.6 The Tender Security of the successful Tenderer shall be returned as promptly as possible once the successful Tenderer has signed the Contract and furnished the required Performance Security, and any other documents required in the **TDS**.

21.7 The Tender Security may be forfeited or the Tender-Securing Declaration executed:

- e) if a Tenderer withdraws its Tender during the period of Tender validity specified by the Tenderer on the Form of Tender, or any extension thereto provided by the Tenderer; or
- f) if the successful Tenderer fails to:
  - i) sign the Contract in accordance with ITT 50; or
  - ii) furnish a Performance Security and if required in the **TDS**, and any other documents required in the **TDS**.

21.8 Where tender securing declaration is executed, the Procuring Entity shall recommend to the PPRA that PPRA debars the Tenderer from participating in public procurement as provided in the law.

21.9 The Tender Security or the Tender-Securing Declaration of a JV shall be in the name of the JV that submits the Tender. If the JV has not been legally constituted into a legally enforceable JV at the time of tendering, the Tender Security or the Tender-Securing Declaration shall be in the names of all future members as named in the letter of intent referred to in ITT 4.1 and ITT 11.2.

21.10 A tenderer shall not issue a tender security to guarantee itself.

## **22. Format and Signing of Tender**

22.1 The Tenderer shall prepare one original of the documents comprising the Tender as described in ITT 13 and clearly mark it "ORIGINAL." Alternative Tenders, if permitted in accordance with ITT 15, shall be clearly marked "ALTERNATIVE." In addition, the Tenderer shall submit copies of the Tender, in the number specified in the **TDS** and clearly mark them "COPY." In the event of any discrepancy between the original and the copies, the original shall prevail.

22.2 Tenderers shall mark as "CONFIDENTIAL" all information in their Tenders which is confidential to their business. This may include proprietary information, trade secrets, or commercial or financially sensitive information.

22.3 The original and all copies of the Tender shall be typed or written in indelible ink and shall be signed by a person duly authorized to sign on behalf of the Tenderer. This authorization shall consist of a written confirmation as specified in the **TDS** and shall be attached to the Tender. The name and position held by each person signing the authorization must be typed or printed below the signature. All pages of the Tender where entries or amendments have been made shall be signed or initialed by the person signing the Tender.

22.4 In case the Tenderer is a JV, the Tender shall be signed by an authorized representative of the JV on behalf of the JV, and to be legally binding on all the members as evidenced by a power of attorney signed by their legally authorized representatives.

22.5 Any inter-lineation, erasures, or overwriting shall be valid only if they are signed or initialed by the person signing the Tender.

## **D. Submission and Opening of Tenders**

### **23. Sealing and Marking of Tenders**

23.1 Depending on the sizes or quantities or weight of the tender documents, a tenderer may use an envelope, package or container. The Tenderer shall deliver the Tender in a single sealed envelope, or in a single sealed package, or in a single sealed container bearing the name and Reference number of the Tender, addressed to the Procuring Entity and a warning not to open before the time and date for Tender opening date. Within the single envelope, package or container, the Tenderer shall place the following separate, sealed envelopes:

- a) in an envelope or package or container marked "ORIGINAL", all documents comprising the Tender, as described in ITT 11; and

- b) in an envelope or package or container marked “COPIES”, all required copies of the Tender; and
- c) if alternative Tenders are permitted in accordance with ITT 15, and if relevant:
  - i) in an envelope or package or container marked “ORIGINAL –ALTERNATIVE TENDER”, the alternative Tender; and
  - ii) in the envelope or package or container marked “COPIES- ALTERNATIVE TENDER”, all required copies of the alternative Tender.

The inner envelopes or packages or containers shall:

- a) bear the name and address of the Procuring Entity.
- b) bear the name and address of the Tenderer; and
- c) bear the name and Reference number of the Tender.

23.2 If an envelope or package or container is not sealed and marked as required, the *Procuring Entity* will assume no responsibility for the misplacement or premature opening of the Tender. Tenders that are misplaced or opened prematurely will not be accepted.

#### **24. Deadline for Submission of Tenders**

24.1 Tenders must be received by the Procuring Entity at the address specified in the **TDS** and no later than the date and time also specified in the **TDS**. When so specified in the **TDS**, Tenderers shall have the option of submitting their Tenders electronically. Tenderers submitting Tenders electronically shall follow the electronic Tender submission procedures specified in the **TDS**.

24.2 The Procuring Entity may, at its discretion, extend the deadline for the submission of Tenders by amending the Tender Documents in accordance with ITT 8, in which case all rights and obligations of the Procuring Entity and Tenderers previously subject to the deadline shall thereafter be subject to the deadline as extended.

#### **25. Late Tenders**

25.1 The Procuring Entity shall not consider any Tender that arrives after the deadline for submission of tenders, in accordance with ITT 24. Any Tender received by the Procuring Entity after the deadline for submission of Tenders shall be declared late, rejected, and returned unopened to the Tenderer.

#### **26. Withdrawal, Substitution, and Modification of Tenders**

26.1 A Tenderer may withdraw, substitute, or modify its Tender after it has been submitted by sending a written notice, duly signed by an authorized representative, and shall include a copy of the authorization in accordance with ITT 22.3, (except that withdrawal notices do not require copies). The corresponding substitution or modification of the Tender must accompany the respective written notice. All notices must be:

- a) prepared and submitted in accordance with ITT 22 and ITT 23 (except that withdrawal notices do not require copies), and in addition, the respective envelopes shall be clearly marked “WITHDRAWAL,” “SUBSTITUTION,” “MODIFICATION;” and
- b) received by the Procuring Entity prior to the deadline prescribed for submission of Tenders, in accordance with ITT 24.

26.2 Tenders requested to be withdrawn in accordance with ITT 26.1 shall be returned unopened to the Tenderers.

26.3 No Tender may be withdrawn, substituted, or modified in the interval between the deadline for submission of Tenders and the expiration of the period of Tender validity specified by the Tenderer on the Form of Tender or any extension thereof.

#### **27. Tender Opening**

27.1 Except in the cases specified in ITT 23 and ITT 26.2, the Procuring Entity shall publicly open and read out all Tenders received by the deadline, at the date, time and place specified in the **TDS**, in the presence of Tenderers' designated representatives who chooses to attend. Any specific electronic Tender opening procedures required if electronic Tendering is permitted in accordance with ITT 24.1, shall be as specified in the **TDS**.

27.2 First, envelopes marked “WITHDRAWAL” shall be opened and read out and the envelopes with the corresponding Tender shall not be opened, but returned to the Tenderer. No Tender withdrawal shall be permitted unless the corresponding withdrawal notice contains a valid authorization to request the withdrawal

and is read out at Tender opening.

- 27.3 Next, envelopes marked “SUBSTITUTION” shall be opened and read out and exchanged with the corresponding Tender being substituted, and the substituted Tender shall not be opened, but returned to the Tenderer. No Tender substitution shall be permitted unless the corresponding substitution notice contains a valid authorization to request the substitution and is read out at Tender opening.
- 27.4 Next, envelopes marked “MODIFICATION” shall be opened and read out with the corresponding Tender. No Tender modification shall be permitted unless the corresponding modification notice contains a valid authorization to request the modification and is read out at Tender opening.
- 27.5 Next, all remaining envelopes shall be opened one at a time, reading out: the name of the Tenderer and whether there is a modification; the total Tender Price, per lot (contract) if applicable, including any discounts and alternative Tenders; the presence or absence of a Tender Security or Tender-Securing Declaration, if required; and any other details as the Procuring Entity may consider appropriate.
- 27.6 Only Tenders, alternative Tenders and discounts that are opened and read out at Tender opening shall be considered further for evaluation. The Form of Tender and pages of the Bills of Quantities are to be initialed by the members of the tender opening committee attending the opening. The number of representatives of the Procuring Entity to sign shall be specified in the **TDS**.
- 27.7 At the Tender Opening, the Procuring Entity shall neither discuss the merits of any Tender nor reject any Tender (except for late Tenders, in accordance with ITT 25.1).
- 27.8 The Procuring Entity shall prepare minutes of the Tender Opening that shall include, as a minimum:
- a) the name of the Tenderer and whether there is a withdrawal, substitution, or modification;
  - b) the Tender Price, per lot (contract) if applicable, including any discounts;
  - c) any alternative Tenders;
  - d) the presence or absence of a Tender Security, if one was required.
  - e) number of pages of each tender document submitted.
- 27.9 The Tenderers' representatives who are present shall be requested to sign the minutes. The omission of a Tenderer's signature on the minutes shall not invalidate the contents and effect of the minutes. A copy of the tender opening register shall be distributed to all Tenderers upon request.

## **E. Evaluation and Comparison of Tenders**

### **28. Confidentiality**

- 28.1 Information relating to the evaluation of Tenders and recommendation of contract award shall not be disclosed to Tenderers or any other persons not officially concerned with the Tender process until information on Intention to Award the Contract is transmitted to all Tenderers in accordance with ITT 46.
- 28.2 Any effort by a Tenderer to influence the Procuring Entity in the evaluation of the Tenders or Contract award decisions may result in the rejection of its tender.
- 28.3 Notwithstanding ITT 28.2, from the time of tender opening to the time of contract award, if a tenderer wishes to contact the Procuring Entity on any **matter related to the tendering process, it shall do so in writing**.

### **29. Clarification of Tenders**

- 29.1 To assist in the examination, evaluation, and comparison of the tenders, and qualification of the tenderers, the Procuring Entity may, at its discretion, ask any tenderer for a clarification of its tender, given a reasonable time for a response. Any clarification submitted by a tenderer that is not in response to a request by the Procuring Entity shall not be considered. The Procuring Entity's request for clarification and the response shall be in writing. No change, including any voluntary increase or decrease, in the prices or substance of the tender shall be sought, offered, or permitted, except to confirm the correction of arithmetic errors discovered by the Procuring Entity in the evaluation of the tenders, in accordance with ITT 33.
- 29.2 If a tenderer does not provide clarifications of its tender by the date and time set in the Procuring Entity's request for clarification, its Tender may be rejected.

### 30. Deviations, Reservations, and Omissions

30.1 During the evaluation of tenders, the following definitions apply:

- a) "Deviation" is a departure from the requirements specified in the tender document;
- b) "Reservation" is the setting of limiting conditions or withholding from complete acceptance of the requirements specified in the tender document; and
- c) "Omission" is the failure to submit part or all of the information or documentation required in the Tender document.

### 31. Determination of Responsiveness

31.1 The Procuring Entity's determination of a Tender's responsiveness is to be based on the contents of the tender itself, as defined in ITT 13.

31.2 A substantially responsive Tender is one that meets the requirements of the Tender document without material deviation, reservation, or omission. **A material deviation, reservation, or omission is one that, if accepted, would:**

- a) affect in any substantial way the scope, quality, or performance of the Works specified in the Contract; or
- b) limit in any substantial way, inconsistent with the tender document, the Procuring Entity's rights or the tenderer's obligations under the proposed contract; or
- c) if rectified, would unfairly affect the competitive position of other tenderers presenting substantially responsive tenders.

31.3 The Procuring Entity shall examine the technical aspects of the tender submitted in accordance with ITT 18, to confirm that all requirements of Section VII, Works' Requirements have been met without any material deviation, reservation or omission.

31.4 If a tender is not substantially responsive to the requirements of the tender document, it shall be rejected by the Procuring Entity and may not subsequently be made responsive by correction of the material deviation, reservation, or omission.

### 32. Non-material Non-conformities

32.1 Provided that a tender is substantially responsive, the Procuring Entity may waive any non-conformities in the tender.

32.2 Provided that a Tender is substantially responsive, the Procuring Entity may request that the tenderer submit the necessary information or documentation, within a reasonable period, to rectify nonmaterial non-conformities in the tender related to documentation requirements. Requesting information or documentation on such non-conformities shall not be related to any aspect of the price of the tender. Failure of the tenderer to comply with the request may result in the rejection of its tender.

32.3 Provided that a tender is substantially responsive, the Procuring Entity shall rectify quantifiable nonmaterial non-conformities related to the Tender Price. To this effect, the Tender Price shall be adjusted, for comparison purposes only, to reflect the price of a missing or non-conforming item or component in the manner specified in the **TDS**.

### 33. Arithmetical Errors

33.1 The tender sum as submitted and read out during the tender opening shall be absolute and final and shall not be the subject of correction, adjustment or amendment in any way by any person or entity.

33.2 Provided that the Tender is substantially responsive, the Procuring Entity shall handle errors on the following basis:

- a) Any error detected if considered a major deviation that affects the substance of the tender, shall lead to disqualification of the tender as non-responsive.
- b) Any errors in the submitted tender arising from a miscalculation of unit price, quantity, and subtotal and total bid price shall be considered as a major deviation that affects the substance of the tender and shall lead to disqualification of the tender as non-responsive. and
- c) if there is a discrepancy between words and figures, the amount in words shall prevail

33.3 Tenderers shall be notified of any error detected in their bid during the notification of a ward.

#### **34. Currency provisions**

34.1 Tenders will be priced in Kenya Shillings only. Tenderers quoting in currencies other than in Kenya shillings will be determined non-responsive and rejected.

#### **35. Margin of Preference and Reservations**

35.1 No margin of preference shall be allowed on contracts for small works.

35.2 Where it is intended to reserve the contract to specific groups under Small and Medium Enterprises, or enterprise of women, youth and/or persons living with disability, who are appropriately registered as such by the authority to be specified in the **TDS**, a procuring entity shall ensure that the invitation to tender specifically indicates that only businesses/firms belonging to those specified groups are the only ones eligible to tender. Otherwise if no so stated, the invitation will be open to all tenderers.

#### **36. Nominated Subcontractors**

36.1 Unless otherwise stated in the **TDS**, the Procuring Entity does not intend to execute any specific elements of the Works by subcontractors selected in advance by the Procuring Entity.

36.2 Tenderers may propose subcontracting up to the percentage of total value of contracts or the volume of works as specified in the **TDS**. Subcontractors proposed by the Tenderer shall be fully qualified for their parts of the Works.

36.3 The subcontractor's qualifications shall not be used by the Tenderer to qualify for the Works unless their specialized parts of the Works were previously designated by the Procuring Entity in the **TDS** as can be met by subcontractors referred to hereafter as 'Specialized Subcontractors', in which case, the qualifications of the Specialized Subcontractors proposed by the Tenderer may be added to the qualifications of the Tenderer.

#### **37. Evaluation of Tenders**

37.1 The Procuring Entity shall use the criteria and methodologies listed in this ITT and Section III, Evaluation and Qualification Criteria. No other evaluation criteria or methodologies shall be permitted. By applying the criteria and methodologies the Procuring Entity shall determine the Best Evaluated Tender in accordance with ITT 40.

37.2 To evaluate a Tender, the Procuring Entity shall consider the following:

- a) price adjustment due to discount offered in accordance with ITT 16;
- b) converting the amount resulting from applying (a) and (b) above, if relevant, to a single currency in accordance with ITT 39;
- c) price adjustment due to quantifiable non-material non-conformities in accordance with ITT 30.3; and
- d) any additional evaluation factors specified in the **TDS** and Section III, Evaluation and Qualification Criteria.

37.3 The estimated effect of the price adjustment provisions of the Conditions of Contract, applied over the period of execution of the Contract, shall not be considered in Tender evaluation.

37.4 In the case of multiple contracts or lots, Tenderers shall be allowed to tender for one or more lots and the methodology to determine the lowest evaluated cost of the lot (contract) combinations, including any discounts offered in the **Form of Tender**, is specified in **Section III, Evaluation and Qualification Criteria**.

#### **38. Comparison of Tenders**

38.1 The Procuring Entity shall compare the evaluated costs of all substantially responsive Tenders established in accordance with ITT 38.2 to determine the Tender that has the lowest evaluated cost.

#### **39. Abnormally Low Tenders**

39.1 An Abnormally Low Tender is one where the Tender price, in combination with other elements of the Tender, appears so low that it raises material concerns as to the capability of the Tenderer in regards to the Tenderer's ability to perform the Contract for the offered Tender Price or that genuine competition between Tenderers is compromised.

39.2 In the event of identification of a potentially Abnormally Low Tender, the Procuring Entity shall seek written clarifications from the Tenderer, including detailed price analyses of its Tender price in relation to the subject matter of the contract, scope, proposed methodology, schedule, allocation of risks and responsibilities and any other requirements of the Tender document.

39.3 After evaluation of the price analyses, in the event that the Procuring Entity determines that the Tenderer has failed to demonstrate its capability to perform the Contract for the offered Tender Price, the Procuring Entity shall reject the Tender.

#### **40. Abnormally High Tenders**

40.1 An abnormally high price is one where the tender price, in combination with other constituent elements of the Tender, appears unreasonably too high to the extent that the Procuring Entity is concerned that it (the Procuring Entity) may not be getting value for money or it may be paying too high a price for the contract compared with market prices or that genuine competition between Tenderers is compromised.

40.2 In case of an abnormally high tender price, the Procuring Entity shall make a survey of the market prices, check if the estimated cost of the contract is correct and review the Tender Documents to check if the specifications, scope of work and conditions of contract are contributory to the abnormally high tenders. The Procuring Entity may also seek written clarification from the tenderer on the reason for the high tender price. The Procuring Entity shall proceed as follows:

- i) If the tender price is abnormally high based on wrong estimated cost of the contract, the Procuring Entity may accept or not accept the tender depending on the Procuring Entity's budget considerations.
- ii) If specifications, scope of work and/or conditions of contract are contributory to the abnormally high tender prices, the Procuring Entity shall reject all tenders and may retender for the contract based on revised estimates, specifications, scope of work and conditions of contract, as the case may be.

40.3 If the Procuring Entity determines that the Tender Price is abnormally too high because genuine competition between tenderers is compromised (*often due to collusion, corruption or other manipulations*), the Procuring Entity shall reject all Tenders and shall institute or cause competent Government Agencies to institute an investigation on the cause of the compromise, before retendering.

#### **41. Unbalanced and/or Front-Loaded Tenders**

41.1 If in the Procuring Entity's opinion, the Tender that is evaluated as the lowest evaluated price is seriously unbalanced and/or front loaded, the Procuring Entity may require the Tenderer to provide written clarifications. Clarifications may include detailed price analyses to demonstrate the consistency of the tender prices with the scope of works, proposed methodology, schedule and any other requirements of the Tender document.

41.2 After the evaluation of the information and detailed price analyses presented by the Tenderer, the Procuring Entity may as appropriate:

- a) accept the Tender; or
- b) require that the total amount of the Performance Security be increased at the expense of the Tenderer to a level not exceeding a 30% of the Contract Price; or
- c) agree on a payment mode that eliminates the inherent risk of the Procuring Entity paying too much for undelivered works; or
- d) reject the Tender,

#### **42. Qualifications of the Tenderer**

42.1 The Procuring Entity shall determine to its satisfaction whether the eligible Tenderer that is selected as having submitted the lowest evaluated cost and substantially responsive Tender, meets the qualifying criteria specified in Section III, Evaluation and Qualification Criteria.

42.2 The determination shall be based upon an examination of the documentary evidence of the Tenderer's qualifications submitted by the Tenderer, pursuant to ITT 19. The determination shall not take into consideration the qualifications of other firms such as the Tenderer's subsidiaries, parent entities, affiliates, subcontractors (other than Specialized Subcontractors if permitted in the Tender document), or any other firm(s) different from the Tenderer.

42.3 An affirmative determination shall be a prerequisite for award of the Contract to the Tenderer. A negative

determination shall result in disqualification of the Tender, in which event the Procuring Entity shall proceed to the Tenderer who offers a substantially responsive Tender with the next lowest evaluated price to make a similar determination of that Tenderer's qualifications to perform satisfactorily.

42.4 An Abnormally Low Tender is one where the Tender price, in combination with other elements of the Tender, appears so low that it raises material concerns as to the capability of the Tenderer in regards to the Tenderer's ability to perform the Contract for the offered Tender Price.

42.5 In the event of identification of a potentially Abnormally Low Tender, the Procuring Entity shall seek written clarifications from the Tenderer, including detailed price analyses of its Tender price in relation to the subject matter of the contract, scope, proposed methodology, schedule, allocation of risks and responsibilities and any other requirements of the Tender document.

42.6 After evaluation of the price analyses, if the Procuring Entity determines that the Tenderer has failed to demonstrate its capability to perform the Contract for the offered Tender Price, the Procuring Entity shall reject the Tender.

#### **43. Best Evaluated Tender**

43.1 Having compared the evaluated prices of Tenders, the Procuring Entity shall determine the Best Evaluated Tender. The Best Evaluated Tender is the Tender of the Tenderer that meets the Qualification Criteria and whose Tender has been determined to be:

- a) Most responsive to the Tender document; and
- b) the lowest evaluated price.

#### **44. Procuring Entity's Right to Accept Any Tender, and to Reject Any or All Tenders.**

44.1 The Procuring Entity reserves the right to accept or reject any Tender and to annul the Tender process and reject all Tenders at any time prior to Contract Award, without thereby incurring any liability to Tenderers. In case of annulment, all Tenderers shall be notified with reasons and all Tenders submitted and specifically, Tender securities, shall be promptly returned to the Tenderers.

### **F. Award of Contract**

#### **45. Award Criteria**

45.1 The Procuring Entity shall award the Contract to the successful tenderer whose tender has been determined to be the Lowest Evaluated Tender.

#### **46. Notice of Intention to enter into a Contract**

46.1 Upon award of the contract and Prior to the expiry of the Tender Validity Period the Procuring Entity shall issue a Notification of Intention to Enter into a Contract / Notification of award to all tenderers which shall contain, at a minimum, the following information:

- a) the name and address of the Tenderer submitting the successful tender;
- b) the Contract price of the successful tender;
- c) a statement of the reason(s) the tender of the unsuccessful tenderer to whom the letter is addressed was unsuccessful, unless the price information in (c) above already reveals the reason;
- d) the expiry date of the Standstill Period; and
- e) instructions on how to request a debriefing and/or submit a complaint during the standstill period;

#### **47. Standstill Period**

47.1 The Contract shall not be signed earlier than the expiry of a Standstill Period of 14 days to allow any dissatisfied tender to launch a complaint. Where only one Tender is submitted, the Standstill Period shall not apply.

47.2 Where a Standstill Period applies, it shall commence when the Procuring Entity has transmitted to each Tenderer the Notification of Intention to Enter **into a Contract with the successful Tenderer.**

#### **48. Debriefing by the Procuring Entity**

48.1 On receipt of the Procuring Entity's Notification of Intention to Enter into a Contract referred to in ITT 46, an unsuccessful tenderer may make a written request to the Procuring Entity for a debriefing on specific issues or concerns regarding their tender. The Procuring Entity shall provide the debriefing within five days of receipt of the request.

48.2 Debriefings of unsuccessful Tenderers may be done in writing or verbally. The Tenderer shall bear its own costs of attending **such a debriefing meeting**.

#### **49. Letter of Award**

49.1 Prior to the expiry of the Tender Validity Period and upon expiry of the Standstill Period specified in ITT 42.1, upon addressing a complaint that has been filed within the Standstill Period, the Procuring Entity shall transmit the Letter of Award to the successful Tenderer. The letter of award shall request the successful tenderer to furnish the Performance Security within 21 days of the date of the letter.

#### **50. Signing of Contract**

50.1 Upon the expiry of the fourteen days of the Notification of Intention to enter into contract and upon the parties meeting their respective statutory requirements, the Procuring Entity shall send the successful Tenderer the Contract Agreement.

50.2 Within fourteen (14) days of receipt of the Contract Agreement, the successful Tenderer shall sign, date, and return it to the Procuring Entity.

50.3 The written contract shall be entered into within the period specified in the notification of award and before expiry of the tender validity period

#### **51. Appointment of Adjudicator**

51.1 The Procuring Entity proposes the person named in the **TDS** to be appointed as Adjudicator under the Contract, at the hourly fee specified in the **TDS**, plus reimbursable expenses. If the Tenderer disagrees with this proposal, the Tenderer should so state in his Tender. If, in the Letter of Acceptance, the Procuring Entity does not agree on the appointment of the Adjudicator, the Procuring Entity will request the Appointing Authority designated in the Special Conditions of Contract (SCC) pursuant to Clause 23.1 of the General Conditions of Contract (GCC), to appoint the Adjudicator.

#### **52. Performance Security**

52.1 Within twenty-one (21) days of the receipt of the Letter of Acceptance from the Procuring Entity, the successful Tenderer shall furnish the Performance Security and, any other documents required in the **TDS**, in accordance with the General Conditions of Contract, subject to ITT 40.2 (b), using the Performance Security and other Forms included in Section X, Contract Forms, or another form acceptable to the Procuring Entity. A foreign institution providing a bank guarantee shall have a correspondent financial institution located in Kenya, unless the Procuring Entity has agreed in writing that a correspondent bank is not required.

52.2 Failure of the successful Tenderer to submit the above-mentioned Performance Security and other documents required in the **TDS**, or sign the Contract shall constitute sufficient grounds for the annulment of the award and forfeiture of the Tender Security. In that event the Procuring Entity may award the Contract to the Tenderer offering the next Best Evaluated Tender.

52.3 Performance security shall not be required for contracts estimated to cost less than Kenya shillings five million shillings.

#### **53. Publication of Procurement Contract**

53.1 Within fourteen days after signing the contract, the Procuring Entity shall publish the awarded contract at its notice boards and websites; and on the Website of the Authority. At the minimum, the notice shall contain the following information:

- a) name and address of the Procuring Entity;
- b) name and reference number of the contract being awarded, a summary of its scope and the selection

- method used;
- c) the name of the successful Tenderer, the final total contract price, the contract duration.
- d) dates of signature, commencement and completion of contract;
- e) names of all Tenderers that submitted Tenders, and their Tender prices as read out at Tender opening.

#### **54. Procurement Related Complaints and Administrative Review**

54.1 The procedures for making Procurement-related Complaints are as specified in the **TDS**.

54.2 A request for administrative review shall be made in the form provided under contract forms.

## Section II - Tender Data Sheet (TDS)

The following specific data shall complement, supplement, or amend the provisions in the Instructions to Tenderers (ITT). Whenever there is a conflict, the provisions herein shall prevail over those in ITT.

ITT Reference	PARTICULARS OF APPENDIX TO INSTRUCTIONS TO TENDERS
	<b>A. General</b>
<b>ITT 1.1</b>	<p><b>THE TENDER REFERENCE NUMBER (ITT) IS: NG-CDF/CHSMEI/DCC/001/2025-2026</b></p> <p><b>THE PROCURING ENTITY IS: NG-CDF CHESUMEI CONSTITUENCY</b></p> <p><b>THE NAME OF THE ITT: Proposed Construction of Digital Hub at Deputy County Commissioner Office-Chesumei</b></p>
<b>ITT 2.1</b>	<b>NOT APPLICABLE</b>
<b>ITT 3.3</b>	The Information made available on competing firms is as follows:
<b>ITT 4.1</b>	Maximum number of members in the Joint Venture (JV) shall be: <b>NONE</b>
<b>B. Contents of Tender Document</b>	
<b>ITT 8.2</b>	The Tenderer will submit any questions in writing, to reach the Procuring Entity not later than 25 <sup>th</sup> June 2026
<b>ITT 8.4</b>	pretender site visit. <b>Allowed</b>

<b>ITT 9.1</b>	For Clarification of Tender purposes, for obtaining further information and for purchasing tender documents, the Procuring Entity's address is:  Attention: NG-CDF CHESUMEI CONSTITUENCY Postal Address: P.O Box 40-30300 KAPSABET
----------------	---

ITT Reference	PARTICULARS OF APPENDIX TO INSTRUCTIONS TO TENDERS
<b>C. Preparation of Tenders</b>	
ITP 13.1 (h)	The Tenderer shall submit the following additional documents in its Tender: <i>AS PER THE EVALUATION CRITERIA AND THE ADVERT</i>
ITT 15.1	Alternative Tenders <b>SHALL NOT</b> be considered.
ITT 15.2	Alternative times for completion <b>SHALL NOT BE</b> permitted.
ITT 15.4	Alternative technical solutions shall be permitted for the following parts of the Works: <b>SHALL NOT BE ALLOWED</b>
ITT 16.5	The prices quoted by the Tenderer shall be <i>FIXED</i>
ITT 20.1	The Tender validity period shall be <b>90 DAYS</b> _
ITT 20.3 (a)	) The delayed to exceeding <u>30</u> number of days. AS PER CONTRACT DAYS  ) The Tender price shall be adjusted by the following percentages of the tender price:
ITT 21.1	A Tender Security of <i>N/A Bid Price shall</i> be required.  If a Tender Security shall be required, the amount and currency of the Tender Security shall be <i>As Above</i> FROM FINANCIAL INSTITUTION RECOGNISED BY Central Bank of Kenya, Bank Guarantee, Credit Note OR INSUARANCE COMPANIES APPROVED BY PPRA
ITT 21.2 (d)	The other Tender Security shall be <u>NOT APPLICABLE</u>
ITT 21.5	On the Performance Security, other documents required shall be <u>AS PER SPECIAL CONDITONS OF CONTRACT</u>
ITT 22.1	In addition to the original of the Tender, the number of copies is: <b>ONLY ORIGINAL</b>
ITT 22.3	The written confirmation of authorization to sign on behalf of the Tenderer shall consist of: <i>WRITEN POWER OF ATTORNEY/ FROM COMMISSIONER OF OATHS</i>
<b>D. Submission and Opening of Tenders</b>	

ITT 24.1	(A) For <u>Tender submission purposes</u> only, the Procuring Entity's address is:  <b>NG-CDF CHESUMEI CONSTITUENCY P.O BOX 40-30300 KAPSABET</b>

ITT Reference	PARTICULARS OF APPENDIX TO INSTRUCTIONS TO TENDERS
ITT 25.1	The deadline for Tender submission is: --- 29 <sup>TH</sup> June, 2026, 2:00 Pm  Tenderers shall not have the option of submitting their Tenders electronically.
ITT 26.1	The Tender opening shall take place at: <b>NG-CDF CHESUMEI CONSTITUENCY BOARDROOM</b> P.O BOX 40-30300 KAPSABET
ITT 26.2	The electronic Tender opening procedures shall NOT be APPLICABLE
ITT 26.6	The Form of Tender and priced Schedule of requirements shall be initialed by TENDER OPENING COMMITTEE

#### E. Evaluation and Comparison of Tenders

ITT 33.2	The currency shall be Kenya Shillings and the source of exchange rate shall be Central bank of Kenya as on as on five (5) calendar days prior to the deadline for submission of bids
ITT 34.2	Margin of preference shall be not allowed.

#### F. Award of Contract

ITT 44.1	The negotiations will be held at NG-CDF CHESUMEI CONSTITUENCY
ITT 49.1	<p>The procedures for making a Procurement-related Complaint are available from the PPRA Website <a href="http://www.ppra.go.ke">www.ppra.go.ke</a> or email <a href="mailto:complaints@ppra.go.ke">complaints@ppra.go.ke</a>.</p> <p>If a Tenderer wishes to make a Procurement-related Complaint, the Tenderer should submit its complaint following these procedures, in writing (by the quickest means available, that is either by hand delivery or email to:</p> <p>For the attention: FUND ACCOUNT MANAGER</p> <p>Procuring Entity: NG-CDF CHESUMEI CONSTITUENCY</p> <p>Email address:</p> <p>In summary, a Procurement-related Complaint may challenge any of the following:</p> <p>(i) the terms of the Tender Documents; and the Procuring Entity's decision to award the contract.</p>

## **SECTION III - EVALUATION AND QUALIFICATION CRITERIA**

### **1. General Provisions**

Wherever a Tenderer is required to state a monetary amount, Tenderers should indicate the Kenya Shilling equivalent using the rate of exchange determined as follows:

- a) For construction turnover or financial data required for each year - Exchange rate prevailing on the last day of the respective calendar year (in which the amounts for that year is to be converted) was originally established.
- b) Value of single contract - Exchange rate prevailing on the date of the contract signature.
- c) Exchange rates shall be taken from the publicly available source identified in the ITT 14.3. Any error in determining the exchange rates in the Tender may be corrected by the Procuring Entity.

This section contains the criteria that the Employer shall use to evaluate tender and qualify tenderers. No other factors, methods or criteria shall be used other than specified in this tender document. The Tenderer shall provide all the information requested in the forms included in Section IV, Tendering Forms. The Procuring Entity should use **the Standard Tender Evaluation Document for Goods and Works** for evaluating Tenders.

#### **Evaluation and contract award Criteria**

The Procuring Entity shall use the criteria and methodologies listed in this Section to evaluate tenders and arrive at the Lowest Evaluated Tender. The tender that (i) meets the qualification criteria, (ii) has been determined to be substantially responsive to the Tender Documents, and (iii) is determined to have the Lowest Evaluated Tender price shall be selected for award of contract.

### **2. Preliminary examination for Determination of Responsiveness**

The Procuring Entity will start by examining all tenders to ensure they meet in all respects the eligibility criteria and other requirements in the ITT, and that the tender is complete in all aspects in meeting the requirements of “Part 2 – Procuring Entity's Works Requirements”, including checking for tenders with unacceptable errors, abnormally low tenders, abnormally high tenders and tenders that are front loaded. The Standard Tender Evaluation Report Document for Goods and Works for evaluating Tenders provides very clear guide on how to deal with review of these requirements. Tenders that do not pass the Preliminary Examination will be considered irresponsive and will not be considered further.

*[The Procuring Entity will provide the preliminary evaluation criteria. To facilitate, a template may be attached or clearly described all information and list of documentation to be submitted by Tenderers to enable preliminary evaluation of the Tender]*

## **STAGE 1: PRELIMINARY EVALUATION**

ITEM	MANDATORY REQUIREMENT (MR) – MAIN CONTRACTOR
MR1	Certificate of Incorporation / Registration from the Registrar of Companies / Businesses;
MR2	(Valid copy of Certificate of CR12 or CR13) for list of directors, beneficial owners, name of proprietor or names of partners issued not more than 12 months before the closure of the tender
MR3	Current Category of Registration with National Construction Authority (NCA) in the relevant trade; (NCA 8 and above for Building Works)
MR 4	Certificate Contractor's Annual Practicing License from NCA for the current year
MR5	Must submit a copy of valid tax compliance
MR6	VAT/PIN registration certificate (Copy).
MR7	<ul style="list-style-type: none"> <li>• Dully filled forms (Original):</li> <li>• Form of tender,</li> <li>• Confidential business questionnaire,</li> <li>• Certificate of independent tender determination,</li> <li>• Self-declaration forms SD1 and SD2 and</li> <li>• Declaration and commitment to the code of ethics</li> </ul>
MR8	Valid copy of Trading / Business Permit
MR9	The Bid has been submitted in the format required by the procuring entity - the tender document to be returned in the order and pages provided in the tender and paginated in sequence including attachments. Use of spiral binding and box files will lead to automatic disqualification.

## STAGE 2: TECHNICAL EVALUATION CRITERIA

The award of points for evidence provided or the standard forms considered in this section shall Be as shown below;

PARAMETER	MAXIMUM POINTS
(i) Key personnel	18
(ii) Contract Completed in the last Five (5) years -----	20
(iii) Schedules of contractor's equipment -----	20
(iv) Audited Financial Report for the last 3 years -----	12
(v) Evidence of Financial Resources -----	15
(vi) Litigation History -----	5
(vii) Work program -----	10
<b>TOTAL</b>	<b>100</b>

Item	Description
<b>T1</b>	<b>Key Personnel (Attach evidence)</b>
	<p><b>1. Director of the firm</b></p> <p>Holder of degree in relevant Engineering field-----6</p> <p>Holder of diploma in relevant Engineering field----- 3</p> <p>Holder of certificate in relevant Engineering field----- 3</p> <p>Holder of Grade I - III test certificate in relevant Engineering field----- 2</p> <p>No relevant certificate ----- 1</p> <p><b>2. At least 1No. degree/diploma holder of key personnel in relevant field</b></p> <ul style="list-style-type: none"> <li>• With over 5 years relevant experience----- 4</li> <li>• With over 3 years relevant experience-----3</li> <li>• With under 1 year's relevant experience----- 2</li> </ul> <p><b>3. At least 1No. Grade III certificate holder of key personnel in relevant field</b></p> <ul style="list-style-type: none"> <li>• With over 5 years relevant experience----- 4</li> <li>• With over 3 years relevant experience-----3</li> <li>• With under 1 year's relevant experience-----2</li> </ul> <p><b>4. At least 1 No artisan (trade test certificate in relevant field)</b></p> <ul style="list-style-type: none"> <li>• Artisan with over 5 years relevant experience----- 4</li> <li>• Artisan with under 3 years relevant experience----- 3</li> <li>• Non skilled worker with over 5 years relevant experience----- 2</li> </ul>
<b>T2</b>	<b>EXPERIENCE</b>
	To Score, the bidder Must attach copies of Completion Certificate confirming successful project completion for each reference.
	<p><b>Contract completed in the last TEN (10) years (Max of 5No. Projects)- <u>Provide Evidence</u></b></p> <ul style="list-style-type: none"> <li>• Project of similar nature, complexity or magnitude----- 20</li> <li>• Project of similar nature but of lower value than the one in consideration - 15</li> <li>• No completed project of similar nature----- 0</li> </ul>
<b>T3</b>	<b>TRANSPORT AND EQUIPMENTS</b>
	<p><b>Schedule of contractor's equipment and transport (proof or evidence of ownership/Lease)</b></p> <p>a) <b>Relevant Transport</b></p> <p>Means of transport (Vehicle)</p> <ul style="list-style-type: none"> <li>• At least 1 pickup ----- 5 marks</li> <li>• At least 1 lorry ----- 5 marks</li> <li>• No means of transport----- 0</li> </ul>

Item	Description
	<b>b) Relevant Equipment</b> (Concrete mixers, Concrete vibrators, Wheel barrows, tile cutters, horse pipes) <ul style="list-style-type: none"> <li>• Has relevant equipment for work being tendered----- 10</li> <li>• No relevant equipment for work being tendered-----0</li> </ul>
<b>T4</b>	<b>FINANCES</b>
	1. Signed and stamped Audited accounts for the last three financial years (2025, 2024, 2023) by certified auditors with ICPAK numbers valid for the 3 years under review/ provide the current valid auditors certificates verifiable on ICPAK portal. <ul style="list-style-type: none"> <li>• Average Annual Turn-over equal to or greater than the cost of the project----- 12</li> <li>• Average Annual Turn-over above 50% but below 100% of the cost of the project ----- 6</li> <li>• Average Annual Turn-over below 50% of the cost of the project - 4</li> </ul> 2. Evidence of Financial Resources (lines of credit/ Bank statement) <ul style="list-style-type: none"> <li>• Has financial resources to finance the projected <b>monthly cash flow</b>*----- 15</li> <li>• Has financial resources equal to the projected <b>monthly cash flow</b>*---- 10</li> <li>• Has financial resources less the projected <b>monthly cash flow</b>* - 5</li> <li>• Has not indicated sources of financial resources----- 0</li> </ul> <b>Monthly Cash Flow = Tender Sum/Contract Period</b>
<b>T5</b>	<b>LITIGATION HISTORY</b>
	No consistent history of court/arbitral award decisions against the Tenderer .....5
<b>T6</b>	<b>WORK PROGRAMME</b>
	Work program in (Gantt chart) and work methodology clearly describing activities with clear timelines <ul style="list-style-type: none"> <li>a. Has both work program and work methodology----- 10</li> <li>b. Has either work program or work methodology----- 5</li> <li>c. No work program and work methodology provided -0</li> </ul>
	<b>TOTAL= 100</b>

### Detailed Scoring Plan

**Tenderers who score 75% and above proceed to financial evaluation**

#### **STAGE 3: FINANCIAL EVALUATION**

##### *A) Determination of the Arithmetic Errors*

Arithmetic Errors will be corrected by the Procuring Entity as follows:

- i) In the event of a discrepancy between the amount as stated in the form of Tender and the corrected tender figure in the Main summary of the Bills of Quantities, the amount as stated in the Form of tender shall prevail. Pursuant to Section 82 of the Public Procurement and Asset Disposal Act 2015, the tender sum as submitted and read out during the tender opening shall be absolute and final and shall not be the subject of correction, adjustment or amendment in any way by any person or entity;
- ii) Error correction factor shall be computed by expressing the difference between the amount and the corrected tender sum as a percentage of the corrected contract works
- iii) The Error correction factor shall be applied to all contract works (as a rebate or addition as the case may be) for the purposes of valuations for Interim Certificates and valuations of variations.

##### *B) Comparison of rates for the bidder*

Items that are under-priced or overpriced may indicate potential for non-delivery and front loading respectively. The



committee shall promptly write to the tenderer asking for detailed breakdown of costs for any of the quoted items, relationship between those prices, proposed construction/installation methods and schedules.

The evaluation committee shall evaluate the responses and make an appropriate recommendation to the procuring entity's tender committee giving necessary evidence. Such recommendations may include but not limited to:

- a) Recommend no adverse action to the tenderer after a convincing response;
- b) Employer requiring that the amount of the performance bond be raised at the expense of the successful tenderer to a level sufficient to protect the employer against potential financial losses;
- c) Recommend non-award based on the response provided and the available demonstrable evidence that the scope, quality, completion timing, administration of works to be undertaken by the tenderer, would adversely be affected or the rights of the employer or the tenderers obligations would be limited in a substantial way.

**C) Consistency of the Rates**

The evaluation committee will compare the consistency of rates for similar items and note all inconsistencies of the rates for similar items

**STAGE 4 - DUE DELIGENCE & RECOMMENDATION FOR AWARD**

<p>Particulars of post – qualification if applicable at Kamobo Secondary School in Emgwen Constituency inspect the premises and under due diligence to seek further clarification/confirmation, if necessary, to confirm authenticity /compliance of any condition of the tender /qualifications of the tenderer in line with <b>Section 83 of the Public Procurement and Asset Disposal Act ,2015</b></p>

Award Criteria:

*The firm achieving the lowest evaluated price will be awarded the contract in line with Section 86 of the Public Procurement and Disposal Act,2015*

3. **Tender Evaluation (ITT 35) Price evaluation:** in addition to the criteria listed in ITT 35.2 (a) – (c) the following criteria shall apply:
- i) **Alternative Completion Times**, if permitted under ITT 13.2, will be evaluated as follows:  
.....
  - ii) **Alternative Technical Solutions** for specified parts of the Works, if permitted under ITT 13.4, will be evaluated as follows: .....

iii) **Other Criteria; if permitted under ITT 35.2(d):**  
.....

**4. Multiple Contracts**

Multiple contracts will be permitted in accordance with ITT 35.4. Tenderers are evaluated on basis of Lots and the lowest evaluated tenderer identified for each Lot. The Procuring Entity will select one Option of the two Options listed below for award of Contracts.

**OPTION 1**

- i) If a tenderer wins only one Lot, the tenderer will be awarded a contract for that Lot, provided the tenderer meets the Eligibility and Qualification Criteria for that Lot.
- ii) If a tenderer wins more than one Lot, the tenderer will be awarded contracts for all won Lots, provided the tenderer meets the aggregate Eligibility and Qualification Criteria for all the Lots. The tenderer will be awarded the combination of Lots for which the tenderer qualifies and the others will be considered for award to second lowest tenderers.

**OPTION 2**

The Procuring Entity will consider all possible combinations of won Lots [contract(s)] and determine the combinations with the lowest evaluated price. Tenders will then be awarded to the Tenderer or Tenderers in the combinations provided the tenderer meets the aggregate Eligibility and Qualification Criteria for all the won Lots.

**5. Alternative Tenders (ITT 13.1)**

*An alternative if permitted under ITT 13.1, will be evaluated as follows:*

The Procuring Entity shall consider Tenders offered for alternatives as specified in Part 2- Works Requirements. Only the technical alternatives, if any, of the Tenderer with the Best Evaluated Tender conforming to the basic technical requirements shall be considered by the Procuring Entity.

**6. Margin of Preference is not applicable**

**7. Post qualification and Contract award (ITT 39), more specifically,**

- a) In case the tender was subject to post-qualification, the contract shall be awarded to the lowest evaluated tenderer, subject to confirmation of pre-qualification data, if so required.
- b) In case the tender was not subject to post-qualification, the tender that has been determined to be the lowest evaluated tenderer shall be considered for contract award, subject to meeting each of the following conditions.
  - i) The Tenderer shall demonstrate that it has access to, or has available, liquid assets, unencumbered real assets, lines of credit, and other financial means (independent of any contractual advance payment) sufficient to meet the construction cash flow of Kenya Shillings \_\_\_\_\_.
  - ii) Minimum average annual construction turnover of Kenya Shillings \_\_\_\_\_ [insert amount], equivalent calculated as total certified payments received for contracts in progress and/or completed within the last \_\_\_\_\_ [insert of year] years.
  - iii) At least \_\_\_\_\_ (insert number) of contract(s) of a similar nature executed within Kenya, or the East African Community or abroad, that have been satisfactorily and substantially completed as a prime contractor, or joint venture member or sub-contractor each of minimum value Kenya shillings \_\_\_\_\_ equivalent.
  - iv) Contractor's Representative and Key Personnel, which are specified as \_\_\_\_\_
  - v) Contractors key equipment listed on the table "Contractor's Equipment" below and more specifically listed as [specify requirements for each lot applicable] \_\_\_\_\_
  - vi) Other conditions depending on their seriousness.
- a) **History of non-performing contracts:**  
Tenderer and each member of JV in case the Tenderer is a JV, shall demonstrate that Non-performance of a contract did not occur because of the default of the Tenderer, or the member of a JV in the last \_\_\_\_\_ (specify years). The required information shall be furnished in the appropriate form.

b) **Pending Litigation**

Financial position and prospective long-term profitability of the Single Tenderer, and in the case the Tenderer is a JV, of each member of the JV, shall remain sound according to criteria established with respect to Financial Capability under Paragraph (i) above if all pending litigation will be resolved against the Tenderer. Tenderer shall provide information on pending litigations in the appropriate form.

c) **Litigation History**

There shall be no consistent history of court/arbitral award decisions against the Tenderer, in the last \_\_\_\_\_ (*specify years*). All parties to the contract shall furnish the information in the appropriate form about any litigation or arbitration resulting from contracts completed or ongoing under its execution over the years specified. A consistent history of awards against the Tenderer or any member of a JV may result in rejection of the tender.

## 8. QUALIFICATION FORMSUMMARY

1	2	3	4	5
Item No.	Qualification Subject	Qualification Requirement	Document To be Completed by Tenderer	For Procuring Entity's Use (Qualification met or Not Met)
1	Nationality	Nationality in accordance with ITT 3.6	Forms ELI – 1.1 and 1.2, with attachments	
2	Tax Obligations for Kenyan Tenderers	Has produced a current tax clearance certificate or tax exemption certificate issued by the the Kenya Revenue Authority in accordance with ITT 3.14.	Form of Tender	
3	Conflict of Interest	No conflicts of interest in accordance with ITT 3.3	Form of Tender	
4	PPRA Eligibility	Not having been declared ineligible by the PPRA as described in ITT 3.8	Form of Tender	
5	State- owned Enterprise	Meets conditions of ITT 3.7	Forms ELI – 1.1 and 1.2, with attachments	
6	Goods, equipment and services to be supplied under the contract	To have their origin in any country that is not determined ineligible under ITT 4.1	Forms ELI – 1.1 and 1.2, with attachments	
7	History of Non-Performing Contracts	Non-performance of a contract did not occur as a result of contractor default since 1 <sup>st</sup> January [.....].	Form CON-2	
8	Suspension Based on Execution of Tender/Proposal Securing Declaration by the Procuring Entity	Not under suspension based on-execution of a Tender/Proposal Securing Declaration pursuant to ITT 19.9	Form of Tender	
9	Pending Litigation	Tender's financial position and prospective long-term profitability still sound according to criteria established in 3.1 and assuming that all pending litigation will NOT be resolved against the Tenderer.	Form CON – 2	
10	Litigation History	No consistent history of court/arbitral award decisions against the Tenderer since 1 <sup>st</sup> January [ <i>insert year</i> ]	Form CON – 2	
11	Financial Capabilities	(i) The Tenderer shall demonstrate that it has access to, or has available, liquid assets, unencumbered real assets, lines of credit, and other financial means (independent of any contractual advance payment) sufficient to meet the construction cash flow requirements estimated as Kenya Shillings [ <i>insert amount</i> ] equivalent for the subject contract(s) net of the Tenderer's other commitments.	Form FIN – 3.1, with attachments	

1	2	3	4	5
Item No.	Qualification Subject	Qualification Requirement	Document To be Completed by Tenderer	For Procuring Entity's Use (Qualification met or Not Met)
		<p>(ii) The Tenderers shall also demonstrate, to the satisfaction of the Procuring Entity, that it has adequate sources of finance to meet the cash flow requirements on works currently in progress and for future contract commitments.</p> <p>(iii) The audited balance sheets or, if not required by the laws of the Tenderer's country, other financial statements acceptable to the Procuring Entity, for the last <i>[insert number of years]</i> years shall be submitted and must demonstrate the current soundness of the Tenderer's financial position and indicate its prospective long-term profitability.</p>		
12	Average Annual Construction Turnover	Minimum average annual construction turnover of Kenya Shillings <i>[insert amount]</i> , equivalent calculated as total certified payments received for contracts in progress and/or completed within the last <i>[insert of year]</i> years, divided by <i>[insert number of years]</i> years	Form FIN – 3.2	
13	General Construction Experience	Experience under construction contracts in the role of prime contractor, JV member, sub-contractor, or management contractor for at least the last <i>[insert number of years]</i> years, starting 1 <sup>st</sup> January <i>[insert year]</i> .	Form EXP – 4.1	
	Specific Construction & Contract Management Experience	<p>A minimum number of <i>[state the number]</i> similar contracts specified below that have been satisfactorily and substantially completed as a prime contractor, joint venture member, management contractor or sub-contractor between 1st January <i>[insert year]</i> and tender submission deadline i.e. .... (number) contracts, each of minimum value Kenya shillings..... equivalent.</p> <p><i>[In case the Works are to be tender as individual contracts under multiple contract procedure, the minimum number of contracts required for purposes of evaluating qualification shall be selected from the options mentioned in ITT 35.4]</i></p> <p>The similarity of the contracts shall be based on the following: <i>[Based on Section VII, Scope of Works, specify</i></p>	Form EXP 4.2(a)	

1 Item No.	2 Qualification Subject	3 Qualification Requirement	4 <i>Document To be Completed by Tenderer</i>	5 <i>For Procuring Entity's Use (Qualification met or Not Met)</i>
		<i>the minimum key requirements in terms of physical size, complexity, construction method, technology and/or other characteristics including part of the requirements that may be met by specialized subcontractors, if permitted in accordance with ITT 34.3]</i>		

## QUALIFICATION FORMS

### 1. FORMEQU: EQUIPMENT

The Tenderer shall provide adequate information to demonstrate clearly that it has the capability to meet the requirements for the key equipment listed in Section III, Evaluation and Qualification Criteria. A separate Form shall be prepared for each item of equipment listed, or for alternative equipment proposed by the Tenderer.

Item of equipment		
Equipment information	Name of manufacturer	Model and power rating
	Capacity	Year of manufacture
Current status	Current location	
	Details of current commitments	
Source	Indicate source of the equipment <input type="checkbox"/> Owned <input type="checkbox"/> Rented <input type="checkbox"/> Leased <input type="checkbox"/> Specially manufactured	

Omit the following information for equipment owned by the Tenderer.

Owner	Name of owner	
	Address of owner	
	Telephone	Contact name and title
	Fax	Telex
Agreements	Details of rental / lease / manufacture agreements specific to the project	



### 3. **FORM PER-2:**

Resume and Declaration - Contractor's Representative and Key Personnel.

Summarize professional experience in reverse chronological order. Indicate particular technical and managerial experience relevant to the project.

<b>Name of Tenderer</b>
-------------------------

Position [#I]: <i>[title of position from Form PER-1]</i>	
Personnel information	Name: <span style="float: right;">Date of birth:</span>
	Address: <span style="float: right;">E-mail:</span>
	Professional qualifications:
	Academic qualifications:
	Language proficiency: <i>[language and levels of speaking, reading and writing skills]</i>
Details	Address of Procuring Entity:
	Telephone: <span style="float: right;">Contact (manager / personnel officer):</span>
	Fax:
	Job title: <span style="float: right;">Years with present Procuring Entity:</span>

Summarize professional experience in reverse chronological order. Indicate particular technical and managerial experience relevant to the project.

<b>Project</b>	<b>Role</b>	<b>Duration of involvement</b>	<b>Relevant experience</b>
<i>[main project details]</i>	<i>[role and responsibilities on the project]</i>	<i>[time in role]</i>	<i>[describe the experience relevant to this position]</i>

## Declaration

I, the undersigned *[insert either "Contractor's Representative" or "Key Personnel" as applicable]*, certify that to the best of my knowledge and belief, the information contained in this Form PER-2 correctly describes myself, my qualifications and my experience.

I confirm that I am available as certified in the following table and throughout the expected time schedule for this position as provided in the Tender:

<b>Commitment</b>	<b>Details</b>
Commitment to duration of contract:	<i>[insert period (start and end dates) for which this Contractor's Representative or Key Personnel is available to work on this contract]</i>
Time commitment:	<i>[insert period (start and end dates) for which this Contractor's Representative or Key Personnel is available to work on this contract]</i>

I understand that any misrepresentation or omission in this Form may:

- a) be taken into consideration during Tender evaluation;
- b) result in my disqualification from participating in the Tender;
- c) result in my dismissal from the contract.

Name of Contractor's Representative or Key Personnel: *[insert name]*

Signature: \_\_\_\_\_

Date:(day month year): \_\_\_\_\_ Countersignature

of authorized representative of the Tenderer:

Signature: \_\_\_\_\_ Date:(daymonth

year): \_\_\_\_\_

#### 4. TENDERER'S QUALIFICATION WITHOUT PRE-QUALIFICATION

To establish its qualifications to perform the contract in accordance with Section III, Evaluation and Qualification Criteria the Tenderer shall provide the information requested in the corresponding Information Sheets included hereunder.

##### 4.1 FORM ELI -1.1

###### Tenderer Information Form

Date: \_\_\_\_\_

ITT No. and title: \_\_\_\_\_

Tenderer's name
In case of Joint Venture (JV), name of each member:
Tenderer's actual or intended country of registration: <i>[indicate country of Constitution]</i>
Tenderer's actual or intended year of incorporation:
Tenderer's legal address [in country of registration]:
Tenderer's authorized representative information Name: _____ Address: _____ Telephone/Fax numbers: _____ E-mail address: _____
1. Attached are copies of original documents of <input type="checkbox"/> Articles of Incorporation (or equivalent documents of constitution or association), and/or documents of registration of the legal entity named above, in accordance with ITT 3.6 <input type="checkbox"/> In case of JV, letter of intent to form JV or JV agreement, in accordance with ITT 3.5 <input type="checkbox"/> In case of state-owned enterprise or institution, in accordance with ITT 3.8, documents establishing: <ul style="list-style-type: none"><li>• Legal and financial autonomy</li><li>• Operation under commercial law</li><li>• Establishing that the Tenderer is not under the supervision of the Procuring Entity</li></ul>
2. Included are the organizational chart and a list of Board of Directors.

## 4.2 **FORMELI-1.2**

### **Tenderer's JV Information Form (to be completed for each member of Tenderer's JV)**

Date: \_\_\_\_\_

ITT No. and title: \_\_\_\_\_

Tenderer's JV name:
JV member's name:
JV member's country of registration:
JV member's year of constitution:
JV member's legal address in country of constitution:
JV member's authorized representative information Name: _____ Address: _____ Telephone/Fax numbers: _____ E-mail address: _____
1. Attached are copies of original documents of <input type="checkbox"/> Articles of Incorporation (or equivalent documents of constitution or association), and/or registration documents of the legal entity named above, in accordance with ITT 3.6. <input type="checkbox"/> In case of a state-owned enterprise or institution, documents establishing legal and financial autonomy, operation in accordance with commercial law, and that they are not under the supervision of the Procuring Entity, in accordance with ITT 3.8.  2. Included are the organizational chart and a list of Board of Directors.

### 4.3 **FORM CON – 2**

#### Historical Contract Non-Performance, Pending Litigation and Litigation History

Tenderer's Name: \_\_\_\_\_

Date: \_\_\_\_\_

JV Member's Name \_\_\_\_\_

ITT No. and title: \_\_\_\_\_

Non-Performed Contracts in accordance with Section III, Evaluation and Qualification Criteria			
<input type="checkbox"/> Contract non-performance did not occur since 1 <sup>st</sup> January <i>[insert year]</i> specified in Section III, Evaluation and Qualification Criteria, Sub-Factor 2.1.			
<input type="checkbox"/> Contract(s) not performed since 1 <sup>st</sup> January <i>[insert year]</i> specified in Section III, Evaluation and Qualification Criteria, requirement 2.1			
Year	Non-performed portion of contract	Contract Identification	Total Contract Amount (current value, currency, exchange rate and Kenya Shilling equivalent)
<i>[insert year]</i>	<i>[insert amount and percentage]</i>	Contract Identification: <i>[indicate complete contract name/ number, and any other identification]</i> Name of Procuring Entity: <i>[insert full name]</i> Address of Procuring Entity: <i>[insert street/city/country]</i> Reason(s) for nonperformance: <i>[indicate main reason(s)]</i>	<i>[insert amount]</i>
Pending Litigation, in accordance with Section III, Evaluation and Qualification Criteria			
<input type="checkbox"/> No pending litigation in accordance with Section III, Evaluation and Qualification Criteria, Sub-Factor 2.3.			
<input type="checkbox"/> Pending litigation in accordance with Section III, Evaluation and Qualification Criteria, Sub-Factor 2.3 as indicated below.			

Year of dispute	Amount in dispute (currency)	Contract Identification	Total Contract Amount (currency), Kenya Shilling Equivalent (exchange rate)
		Contract Identification: _____ Name of Procuring Entity: _____ Address of Procuring Entity: _____ Matter in dispute: _____ Party who initiated the dispute: _____ Status of dispute: _____	
		Contract Identification: _____ Name of Procuring Entity: _____ Address of Procuring Entity: _____ Matter in dispute: _____ Party who initiated the dispute: _____ Status of dispute: _____	
Litigation History in accordance with Section III, Evaluation and Qualification Criteria			
<input type="checkbox"/> No Litigation History in accordance with Section III, Evaluation and Qualification Criteria, Sub-Factor 2.4.			
<input type="checkbox"/> Litigation History in accordance with Section III, Evaluation and Qualification Criteria, Sub-Factor 2.4 as indicated below.			

Year of award	Outcome as percentage of Net Worth	Contract Identification	Total Contract Amount (currency), Kenya Shilling Equivalent (exchange rate)
[insert year]	[insert percentage]	Contract Identification: [indicate complete contract name, number, and any other identification] Name of Procuring Entity: [insert full name] Address of Procuring Entity: [insert street/city/country] Matter in dispute: [indicate main issues in dispute] Party who initiated the dispute: [indicate "Procuring Entity" or "Contractor"] Reason(s) for Litigation and award decision [indicate main reason(s)]	[insert amount]

#### 4.4 **FORM FIN – 3.1:**

##### Financial Situation and Performance

Tenderer's Name: \_\_\_\_\_  
 Date: \_\_\_\_\_  
 JV Member's Name \_\_\_\_\_  
 ITT No. and title: \_\_\_\_\_

##### 4.4.1. Financial Data

Type of Financial information in _____ (currency)	Historic information for previous _____ years, (amount in currency, currency, exchange rate*, USD equivalent)				
	Year 1	Year 2	Year 3	Year 4	Year 5
Statement of Financial Position (Information from Balance Sheet)					
Total Assets (TA)					
Total Liabilities (TL)					
Total Equity/Net Worth (NW)					
Current Assets (CA)					
Current Liabilities (CL)					
Working Capital (WC)					
Information from Income Statement					
Total Revenue (TR)					

Type of Financial information in _____ (currency)	Historic information for previous _____ years,				
	(amount in currency, currency, exchange rate*, USD equivalent)				
	Year 1	Year 2	Year 3	Year 4	Year 5
Profits Before Taxes (PBT)					
Cash Flow Information					
Cash Flow from Operating Activities					

\*Refer to ITT 15 for the exchange rate

#### 4.4.2 Sources of Finance

Specify sources of finance to meet the cash flow requirements on works currently in progress and for future contract commitments.

No.	Source of finance	Amount (Kenya Shilling equivalent)
1		
2		
3		

#### 4.4.3 Financial documents

The Tenderer and its parties shall provide copies of financial statements for \_\_\_\_\_ years pursuant Section III, Evaluation and Qualifications Criteria, Sub-factor 3.1. The financial statements shall:

- (a) reflect the financial situation of the Tenderer or in case of JV member, and not an affiliated entity (such as parent company or group member).
- (b) be independently audited or certified in accordance with local legislation.
- (c) be complete, including all notes to the financial statements.
- (d) correspond to accounting periods already completed and audited.

Attached are copies of financial statements<sup>1</sup> for the \_\_\_\_\_ years required above; and complying with the requirements

<sup>1</sup> If the most recent set of financial statements is for a period earlier than 12 months from the date of Tender, the reason for this should be justified.

#### 4.5 FORM FIN – 3.2:

##### Average Annual Construction Turnover

Tenderer's Name: \_\_\_\_\_

Date: \_\_\_\_\_

JV Member's Name \_\_\_\_\_

ITT No. and title: \_\_\_\_\_

Annual turnover data (construction only)			
Year	Amount Currency	Exchange rate	Kenya Shilling equivalent
<i>[indicate year]</i>	<i>[insert amount and indicate currency]</i>		
Average Annual Construction Turnover *			

\* See Section III, Evaluation and Qualification Criteria, Sub-Factor 3.2.

#### 4.6 FORM FIN – 3.3:

##### Financial Resources

Specify proposed sources of financing, such as liquid assets, unencumbered real assets, lines of credit, and other financial means, net of current commitments, available to meet the total construction cash flow demands of the subject contract or contracts as specified in Section III, Evaluation and Qualification Criteria

Financial Resources		
No.	Source of financing	Amount (Kenya Shilling equivalent)
1		
2		
3		

#### 4.7 FORM EN – 3.4:

### Current Contract Commitments / Works in Progress

Tenderers and each member to a JV should provide information on their current commitments on all contracts that have been awarded, or for which a letter of intent or acceptance has been received, or for contracts approaching completion, but for which an unqualified, full completion certificate has yet to be issued.

<b>Current Contract Commitments</b>					
	<b>Name of Contract</b>	<b>Procuring Entity's Contact Address, Tel,</b>	<b>Value of Outstanding Work [Current Kenya Shilling /month Equivalent]</b>	<b>Estimated Completion Date</b>	<b>Average Monthly Invoicing Over Last Six Months [Kenya Shilling /month]</b>
1					
2					
3					
4					
5					

**4.8 FORM EXP - 4.1**

**General Construction Experience**

Tenderer's Name: \_\_\_\_\_

Date: \_\_\_\_\_

JV Member's Name \_\_\_\_\_

ITT No. and title: \_\_\_\_\_

Page \_\_\_\_\_ of \_\_\_\_\_ pages

Starting Year	Ending Year	Contract Identification	Role of Tenderer
		Contractname: _____ Brief Description of the Works performed by the Tenderer: _____ Amount of contract: _____ Name of Procuring Entity: _____ Address: _____	
		Contract name: _____ Brief Description of the Works performed by the Tenderer: _____ Amount of contract: _____ Name of Procuring Entity: _____ Address: _____	
		Contractname: _____ Brief Description of the Works performed by the Tenderer: _____ Amount of contract: _____ Name of Procuring Entity: _____ Address: _____	

#### 4.9 FORM EXP - 4.2(a)

##### Specific Construction and Contract Management Experience

Tenderer's Name: \_\_\_\_\_

Date: \_\_\_\_\_

JV Member's Name \_\_\_\_\_

ITT No. and title: \_\_\_\_\_

Similar Contract No.	Information			
Contract Identification				
Award date				
Completion date				
Role in Contract	Prime Contractor <input type="checkbox"/>	Member in JV <input type="checkbox"/>	Management Contractor <input type="checkbox"/>	Sub-contractor <input type="checkbox"/>
Total Contract Amount				<b>Kenya Shilling</b>
If member in a JV or sub-contractor, specify participation in total Contract amount				
Procuring Entity's Name:				
Address:				
Telephone/fax number				
E-mail:				

#### 4.10 FORM EXP - 4.2 (a) (cont.)

##### Specific Construction and Contract Management Experience (cont.)

Similar Contract No.	Information
Description of the similarity in accordance with Sub-Factor 4.2(a) of Section III:	
1. Amount	
2. Physical size of required works items	
3. Complexity	
4. Methods/Technology	
5. Construction rate for key activities	
6. Other Characteristics	

#### 4.11 FORM EXP - 4.2(b)

### Construction Experience in Key Activities

Tenderer's Name: \_\_\_\_\_

Date: \_\_\_\_\_

Tenderer's JV Member Name: \_\_\_\_\_

Sub-contractor's Name<sup>2</sup> (as per ITT 34): \_\_\_\_\_

ITT No. and title: \_\_\_\_\_

All Sub-contractors for key activities must complete the information in this form as per ITT 34 and Section III, Evaluation and Qualification Criteria, Sub-Factor 4.2.

1. Key Activity No One: \_

Information				
Contract Identification				
Award date				
Completion date				
Role in Contract	Prime Contractor <input type="checkbox"/>	Member in JV <input type="checkbox"/>	Management Contractor <input type="checkbox"/>	Sub-contractor <input type="checkbox"/>
Total Contract Amount			Kenya Shilling	
Quantity (Volume, number or rate of production, as applicable) performed under the contract per year or part of the year	Total quantity in the contract (i)	Percentage participation (ii)		Actual Quantity Performed (i) x (ii)
Year 1				
Year 2				
Year 3				
Year 4				
Procuring Entity's Name:				
Address: Telephone/fax number E-mail:				

<sup>2</sup> If applicable

	<b>Information</b>
Description of the key activities in accordance with Sub-Factor 4.2(b) of Section III:	

2. Activity No. Two

3. ....

## **OTHER FORMS**

### **5. FORM OF TENDER**

**(Amended and issued pursuant to PPRA CIRCULAR No. 02/2022)**

#### ***INSTRUCTIONS TO TENDERERS***

- i) All italicized text is to help the Tenderer in preparing this form.*
- ii) The Tenderer must prepare this Form of Tender on stationery with its letterhead clearly showing the Tenderer's complete name and business address. Tenderers are reminded that this is a mandatory requirement.*
- iii) Tenderer must complete and sign CERTIFICATE OF INDEPENDENT TENDER DETERMINATION and the SELF DECLARATION FORMS OF THE TENDERER as listed under (s) below.*

**Date of this Tender submission:**.....[insert date (as day, month and year) of Tender submission] **Tender**

**Name**                      **and**                      **Identification:**.....[insert                      *identification*] **Alternative**

**No.:**.....[insert identification No if this is a Tender for an alternative]

To.....[Insert complete name of Procuring Entity]

Dear Sirs,

1. In accordance with the Conditions of Contract, Specifications, Drawings and Bills of Quantities for the execution of the above named Works, we, the undersigned offer to construct and complete the Works and remedy any defects therein for the sum of Kenya Shillings [[Amount in figures]\_\_\_\_\_ Kenya Shillings [amount in words]\_\_\_\_\_.

The above amount includes foreign currency amount (s) of [state figure or a percentage and currency] [figures]\_\_\_\_\_ [words]\_\_\_\_\_.

The percentage or amount quoted above does not include provisional sums, and only allows not more than two foreign currencies.

2. We undertake, if our tender is accepted, to commence the Works as soon as is reasonably possible after the receipt of the Project Manager's notice to commence, and to complete the whole of the Works comprised in the Contract within the time stated in the Special Conditions of Contract.
3. We agree to adhere by this tender until \_\_\_\_\_ [Insert date], and it shall remain binding upon us and may be accepted at any time before that date.
4. Unless and until a formal Agreement is prepared and executed this tender together with your written acceptance thereof, shall constitute a binding Contract between us. We further understand that you are not bound to accept the lowest or any tender you may receive.
5. We, the undersigned, further declare that:
  - i) No reservations: We have examined and have no reservations to the tender document, including Addenda issued in accordance with ITT 28;
  - ii) Eligibility: We meet the eligibility requirements and have no conflict of interest in accordance with ITT 3 and 4;
  - iii) Tender-Securing Declaration: We have not been suspended nor declared ineligible by the Procuring Entity based on execution of a Tender-Securing or Proposal-Securing Declaration in the Procuring Entity's Country in accordance with ITT 19.8;
  - iv) Conformity: We offer to execute in conformity with the tendering documents and in accordance with the implementation and completion specified in the construction schedule, the following Works: [insert a brief description of the Works];

- v) Tender Price: The total price of our Tender, excluding any discounts offered in item 1 above is: *[Insert one of the options below as appropriate]*
- vi) Option 1, in case of one lot: Total price is: *[insert the total price of the Tender in words and figures, indicating the various amounts and the respective currencies]*; Or
- Option 2, in case of multiple lots:
- a) Total price of each lot *[insert the total price of each lot in words and figures, indicating the various amounts and the respective currencies]*; and
- b) Total price of all lots (sum of all lots) *[insert the total price of all lots in words and figures, indicating the various amounts and the respective currencies]*;
- vii) Discounts: The discounts offered and the methodology for their application are:
- viii) The discounts offered are: *[Specify in detail each discount offered.]*
- ix) The exact method of calculations to determine the net price after application of discounts is shown below: *[Specify in detail the method that shall be used to apply the discounts]*;
- x) Tender Validity Period: Our Tender shall be valid for the period specified in TDS 18.1 (as amended, if applicable) from the date fixed for the Tender submission deadline specified in TDS 22.1 (as amended, if applicable), and it shall remain binding upon us and may be accepted at any time before the expiration of that period;
- xi) Performance Security: If our Tender is accepted, we commit to obtain a Performance Security in accordance with the Tendering document;
- xii) One Tender Per Tender: We are not submitting any other Tender(s) as an individual Tender, and we are not participating in any other Tender(s) as a Joint Venture member or as a subcontractor, and meet the requirements of ITT 3.4, other than alternative Tenders submitted in accordance with ITT 13.3;
- xiii) Suspension and Debarment: We, along with any of our subcontractors, suppliers, Project Manager, manufacturers, or service providers for any part of the contract, are not subject to, and not controlled by any entity or individual that is subject to, a temporary suspension or a debarment imposed by the Public Procurement Regulatory Authority or any other entity of the Government of Kenya, or any international organization.
- xiv) State-owned enterprise or institution: *[select the appropriate option and delete the other]* *[We are not a state-owned enterprise or institution]* / *[We are a state-owned enterprise or institution but meet the requirements of ITT 3.8]*;
- xv) Commissions, gratuities, fees: We have paid, or will pay the following commissions, gratuities, or fees with respect to the tender process or execution of the Contract: *[insert complete name of each Recipient, its full address, the reason for which each commission or gratuity was paid and the amount and currency of each such commission or gratuity]*.

Name of Recipient	Address	Reason	Amount

*(If none has been paid or is to be paid, indicate "none.")*

- xvi) Binding Contract: We understand that this Tender, together with your written acceptance thereof included in your Letter of Acceptance, shall constitute a binding contract between us, until a formal contract is prepared and executed;
- xvii) Not Bound to Accept: We understand that you are not bound to accept the lowest evaluated cost Tender, the Most Advantageous Tender or any other Tender that you may receive;
- xviii) Fraud and Corruption: We hereby certify that we have taken steps to ensure that no person acting for us or on our behalf engages in any type of Fraud and Corruption;

- xix) **Collusive practices:** We hereby certify and confirm that the tender is genuine, non-collusive and made with the intention of accepting the contract if awarded. To this effect we have signed the “Certificate of Independent Tender Determination” attached below.
- xx) We undertake to adhere by the Code of Ethics for Persons Participating in Public Procurement and Asset Disposal, copy available from \_\_\_\_\_ (*specify website*) during the procurement process and the execution of any resulting contract.
- xxi) **Beneficial Ownership Information:** We commit to provide to the procuring entity the Beneficial Ownership Information in conformity with the Beneficial Ownership Disclosure Form upon receipt of notification of intention to enter into a contract in the event we are the successful tenderer in this subject procurement proceeding.
- xxii) We, the Tenderer, have duly completed, signed and stamped the following Forms as part of our Tender:
- a) Tenderer's Eligibility; Confidential Business Questionnaire – to establish we are not in any conflict to interest.
  - b) Certificate of Independent Tender Determination – to declare that we completed the tender without colluding with other tenderers.
  - c) Self-Declaration of the Tenderer – to declare that we will, if awarded a contract, not engage in any form of fraud and corruption.
  - d) Declaration and commitment to the Code of Ethics for Persons Participating in Public Procurement and Asset Disposal

Further, we confirm that we have read and understood the full content and scope of fraud and corruption as informed in “**Appendix 1- Fraud and Corruption**” attached to the Form of Tender.

**Name of the Tenderer:** \*[insert complete name of person signing the Tender]

**Name of the person duly authorized to sign the Tender on behalf of the Tenderer:** \*\*[insert complete name of person duly authorized to sign the Tender]

**Title of the person signing the Tender:**[insert complete title of the person signing the Tender]

**Signature of the person named above:** [insert signature of person whose name and capacity are shown above] **Date signed** [insert date of signing] day of [insert month], [insert year]

Date signed \_\_\_\_\_ day of \_\_\_\_\_, \_\_\_\_\_

**Notes**

\* In the case of the Tender submitted by joint venture specify the name of the Joint Venture as Tenderer

\*\* Person signing the Tender shall have the power of attorney given by the Tenderer to be attached with the Tender.

## A. TENDERER'S ELIGIBILITY- CONFIDENTIAL BUSINESS QUESTIONNAIRE

### Instruction to Tenderer

Tender is instructed to complete the particulars required in this Form, *one form for each entity if Tender is a JV*. Tenderer is further reminded that it is an offence to give false information on this Form.

#### (a) Tenderer's details

	ITEM	DESCRIPTION
1	Name of the Procuring Entity	
2	Reference Number of the Tender	
3	Date and Time of Tender Opening	
4	Name of the Tenderer	
5	Full Address and Contact Details of the Tenderer.	<ol style="list-style-type: none"> <li>1. Country</li> <li>2. City</li> <li>3. Location</li> <li>4. Building</li> <li>5. Floor</li> <li>6. Postal Address</li> <li>7. Name and email of contact person.</li> </ol>
6	Current Trade License Registration Number and Expiring date	
7	Name, country and full address ( <i>postal and physical addresses, email, and telephone number</i> ) of Registering Body/Agency	
8	Description of Nature of Business	
9	Maximum value of business which the Tenderer handles.	
10	State if Tenders Company is listed in stock exchange, give name and full address ( <i>postal and physical addresses, email, and telephone number</i> ) of state which stock exchange	

**General and Specific Details**

b) **Sole Proprietor**, provide the following details.

Name in full \_\_\_\_\_ Age \_\_\_\_\_ Nationality \_\_\_\_\_  
 \_\_\_\_\_ Country of Origin \_\_\_\_\_ Citizenship \_\_\_\_\_  
 \_\_\_\_\_

c) **Partnership**, provide the following details.

	Names of Partners	Nationality	Citizenship	% Shares owned
1				
2				
3				

d) **Registered Company**, provide the following details.

i) Private or public Company \_\_\_\_\_

ii) State the nominal and issued capital of the Company \_\_\_\_\_

Nominal Kenya Shillings (Equivalent)..... Issued

Kenya Shillings (Equivalent).....

iii) Give details of Directors as follows.

	Names of Director	Nationality	Citizenship	% Shares owned
1				
2				
3				

(e) **DISCLOSURE OF INTEREST- Interest of the Firm in the Procuring Entity.**

i) Are there any person/persons in..... (*Name of Procuring Entity*) who has/have an interest or relationship in this firm? Yes/No.....

If yes, provide details as follows.

	Names of Person	Designation in the Procuring Entity	Interest or Relationship with Tenderer
1			
2			
3			

ii) **Conflict of interest disclosure**

	Type of Conflict	Disclosure YES OR NO	If YES provide details of the relationship with Tenderer
1	Tenderer is directly or indirectly controls, is controlled by or is under common control with another tenderer.		
2	Tenderer receives or has received any direct or indirect subsidy from another tenderer.		
3	Tenderer has the same legal representative as another tenderer		
4	Tender has a relationship with another tenderer, directly or through common third parties, that puts it in a position to influence the tender of another tenderer, or influence the decisions of the Procuring Entity regarding this tendering process.		

	Type of Conflict	Disclosure YES OR NO	If YES provide details of the relationship with Tenderer
5	Any of the Tenderer's affiliates participated as a consultant in the preparation of the design or technical specifications of the works that are the subject of the tender.		
6	Tenderer would be providing goods, works, non-consulting services or consulting services during implementation of the contract specified in this Tender Document.		
7	Tenderer has a close business or family relationship with a professional staff of the Procuring Entity who are directly or indirectly involved in the preparation of the Tender document or specifications of the Contract, and/or the Tender evaluation process of such contract.		
8	Tenderer has a close business or family relationship with a professional staff of the Procuring Entity who would be involved in the implementation or supervision of the such Contract.		
9	Has the conflict stemming from such relationship stated in item 7 and 8 above been resolved in a manner acceptable to the Procuring Entity throughout the tendering process and execution of the Contract.		

**f) Certification**

On behalf of the Tenderer, I certify that the information given above is complete, current and accurate as at the date of submission.

Full Name \_\_\_\_\_ Title or

Designation \_\_\_\_\_

\_\_\_\_\_  
(Signature)

\_\_\_\_\_  
(Date)

## B. CERTIFICATE OF INDEPENDENT TENDER DETERMINATION

I, the undersigned, in submitting the accompanying Letter of Tender to the \_\_\_\_\_ [Name of Procuring Entity] for: \_\_\_\_\_ [Name and number of tender] in response to the request for tenders made by: \_\_\_\_\_ [Name of Tenderer] do hereby make the following statements that I certify to be true and complete in every respect:

I certify, on behalf of \_\_\_\_\_ [Name of Tenderer] that:

1. I have read and understand the contents of this Certificate;
2. I understand that the Tender will be disqualified if this Certificate is found not to be true and complete in every respect;
3. I am the authorized representative of the Tenderer with authority to sign this Certificate, and to submit the Tender on behalf of the Tenderer;
4. For the purposes of this Certificate and the Tender, I understand that the word "competitor" shall include any individual or organization, other than the Tenderer, whether or not affiliated with the Tenderer, who:
  - a) has been requested to submit a Tender in response to this request for tenders;
  - b) could potentially submit a tender in response to this request for tenders, based on their qualifications, abilities or experience;
5. The Tenderer discloses that [check one of the following, as applicable]:
  - a) The Tenderer has arrived at the Tender independently from, and without consultation, communication, agreement or arrangement with, any competitor;
  - b) the Tenderer has entered into consultations, communications, agreements or arrangements with one or more competitors regarding this request for tenders, and the Tenderer discloses, in the attached document(s), complete details thereof, including the names of the competitors and the nature of, and reasons for, such consultations, communications, agreements or arrangements;
6. In particular, without limiting the generality of paragraphs (5)(a) or (5)(b) above, there has been no consultation, communication, agreement or arrangement with any competitor regarding:
  - a) prices;
  - b) methods, factors or formulas used to calculate prices;
  - c) the intention or decision to submit, or not to submit, a tender; or
  - d) the submission of a tender which does not meet the specifications of the request for Tenders; except as specifically disclosed pursuant to paragraph (5)(b) above;
7. In addition, there has been no consultation, communication, agreement or arrangement with any competitor regarding the quality, quantity, specifications or delivery particulars of the works or services to which this request for tenders relates, except as specifically authorized by the procuring authority or as specifically disclosed pursuant to paragraph (5)(b) above;
8. the terms of the Tender have not been, and will not be, knowingly disclosed by the Tenderer, directly or indirectly, to any competitor, prior to the date and time of the official tender opening, or of the awarding of the Contract, whichever comes first, unless otherwise required by law or as specifically disclosed pursuant to paragraph (5)(b) above.

Name \_\_\_\_\_ Title \_\_\_\_\_ Date \_\_\_\_\_

*[Name, title and signature of authorized agent of Tenderer and Date].*



**FORM SD2**

**SELF DECLARATION THAT THE PERSON/TENDERER WILL NOT ENGAGE IN ANY CORRUPT OR FRAUDULENT PRACTICE**

I, ..... of P. O. Box..... being a resident of ..... in the Republic of..... do hereby make a statement as follows: -

1. THAT I am the Chief Executive/Managing Director/Principal Officer/Director of..... (*insert name of the Company*) who is a Bidder in respect of Tender No..... for ..... (*insert tender title/description*) for..... (*insert name of the Procuring entity*) and duly authorized and competent to make this statement.
2. THAT the aforesaid Bidder, its servants and/or agents /subcontractors will not engage in any corrupt or fraudulent practice and has not been requested to pay any inducement to any member of the Board, Management, Staff and/or employees and/or agents of..... (*insert name of the Procuring entity*) which is the procuring entity.
3. THAT the aforesaid Bidder, its servants and/or agents /subcontractors have not offered any inducement to any member of the Board, Management, Staff and/or employees and/or agents of.....(name of the procuring entity)
4. THAT the aforesaid Bidder will not engage /has not engaged in any corrosive practice with other bidders participating in the subject tender
5. THAT what is deponed to herein above is true to the best of my knowledge information and belief.

.....  
(Title)

.....  
(Signature)

.....  
(Date)

Bidder's Official Stamp

**DECLARATION AND COMMITMENT TO THE CODE OF ETHICS**

I ..... (person) on behalf of (*Name of the Business/ Company/Firm*)..... declare that I have read and fully understood the contents of the Public Procurement & Asset Disposal Act, 2015, Regulations and the Code of Ethics for persons participating in Public Procurement and Asset Disposal and my responsibilities under the Code.

Ido hereby commit to abide by the provisions of the Code of Ethicsfor persons participating in Public Procurement and Asset Disposal.

Name of Authorized signatory..... Sign.....

Position.....

Office address..... Telephone.....

E-mail.....

Name of the Firm/Company.....

Date..... (Company Seal/ Rubber

Stamp where applicable)

Witness

Name ..... Sign.....

Date.....

## D. APPENDIX 1- FRAUD AND CORRUPTION

*(Appendix 1 shall not be modified)*

### 1. Purpose

2. The Government of Kenya's Anti-Corruption and Economic Crime laws and their sanctions policies and procedures, Public Procurement and Asset Disposal Act (*no. 33 of 2015*) and its Regulation, and any other Kenya's Acts or Regulations related to Fraud and Corruption, and similar offences, shall apply with respect to Public Procurement Processes and Contracts that are governed by the laws of Kenya.

### 3. Requirements

The Government of Kenya requires that all parties including Procuring Entities, Tenderers, (applicants/proposers), Consultants, Contractors and Suppliers; any Sub-contractors, Sub-consultants, Service providers or Suppliers; any Agents (whether declared or not); and any of their Personnel, involved and engaged in procurement under Kenya's Laws and Regulation, observe the highest standard of ethics during the procurement process, selection and contract execution of all contracts, and refrain from Fraud and Corruption and fully comply with Kenya's laws and Regulations as per paragraphs 1.1 above.

Kenya's public procurement and asset disposal act (*no. 33 of 2015*) under Section 66 describes rules to be followed and actions to be taken in dealing with Corrupt, Coercive, Obstructive, Collusive or Fraudulent practices, and Conflicts of Interest in procurement including consequences for offences committed. A few of the provisions noted below highlight Kenya's policy of no tolerance for such practices and behavior: -

- 1) a person to whom this Act applies shall not be involved in any corrupt, coercive, obstructive, collusive or fraudulent practice; or conflicts of interest in any procurement or asset disposal proceeding;
- 2) A person referred to under subsection (1) who contravenes the provisions of that sub-section commits an offence;
- 3) Without limiting the generality of the subsection (1) and (2), the persons shall be: -
  - a) disqualified from entering into a contract for a procurement or asset disposal proceeding; or
  - b) if a contract has already been entered into with the person, the contract shall be voidable;
- 4) The voiding of a contract by the procuring entity under subsection (7) does not limit any legal remedy the procuring entity may have;
- 5) An employee or agent of the procuring entity or a member of the Board or committee of the procuring entity who has a conflict of interest with respect to a procurement: -
  - a) shall not take part in the procurement proceedings;
  - b) shall not, after a procurement contract has been entered into, take part in any decision relating to the procurement or contract; and
- c) shall not be a subcontractor for the bidder to whom was awarded contract, or a member of the group of bidders to whom the contract was awarded, but the subcontractor appointed shall meet all the requirements of this Act.
- 6) An employee, agent or member described in subsection (1) who refrains from doing anything prohibited under that subsection, but for that subsection, would have been within his or her duties shall disclose the conflict of interest to the procuring entity;
- 7) If a person contravenes subsection (1) with respect to a conflict of interest described in subsection (5)(a) and the contract is awarded to the person or his relative or to another person in whom one of them had a direct or indirect pecuniary interest, the contract shall be terminated and all costs incurred by the public entity shall be made good by the awarding officer. Etc.

In compliance with Kenya's laws, regulations and policies mentioned above, the Procuring Entity:

- a) Defines broadly, for the purposes of the above provisions, the terms set forth below as follows:
  - i) "corrupt practice" is the offering, giving, receiving, or soliciting, directly or indirectly, of anything of value to influence improperly the actions of another party;
  - ii) "fraudulent practice" is any act or omission, including misrepresentation, that knowingly or recklessly misleads, or attempts to mislead, a party to obtain financial or other benefit or to avoid an obligation;

- iii) “collusive practice” is an arrangement between two or more parties designed to achieve an improper purpose, including to influence improperly the actions of another party;
  - iv) “coercive practice” is impairing or harming, or threatening to impair or harm, directly or indirectly, any party or the property of the party to influence improperly the actions of a party;
  - v) “obstructive practice” is:
    - deliberately destroying, falsifying, altering, or concealing of evidence material to the investigation or making false statements to investigators in order to materially impede investigation by Public Procurement Regulatory Authority (PPRA) or any other appropriate authority appointed by Government of Kenya into allegations of a corrupt, fraudulent, coercive, or collusive practice; and/or threatening, harassing, or intimidating any party to prevent it from disclosing its knowledge of matters relevant to the investigation or from pursuing the investigation; or
    - acts intended to materially impede the exercise of the PPRA's or the appointed authority's inspection and audit rights provided for under paragraph 2.3 e. below.
- b) Defines more specifically, in accordance with the above procurement Act provisions set forth for fraudulent and collusive practices as follows:
- "fraudulent practice" includes a misrepresentation of fact in order to influence a procurement or disposal process or the exercise of a contract to the detriment of the procuring entity or the tenderer or the contractor, and includes collusive practices amongst tenderers prior to or after tender submission designed to establish tender prices at artificial non-competitive levels and to deprive the procuring entity of the benefits of free and open competition.
- c) Rejects a proposal for award<sup>1</sup> of a contract if PPRA determines that the firm or individual recommended for award, any of its personnel, or its agents, or its sub-consultants, sub-contractors, service providers, suppliers and/ or their employees, has, directly or indirectly, engaged in corrupt, fraudulent, collusive, coercive, or obstructive practices in competing for the contract in question;
  - d) Pursuant to the Kenya's above stated Acts and Regulations, may sanction or recommend to appropriate authority (ies) for sanctioning and debarment of a firm or individual, as applicable under the Acts and Regulations;
  - e) Requires that a clause be included in Tender documents and Request for Proposal documents requiring (i) Tenderers (applicants/proposers), Consultants, Contractors, and Suppliers, and their Sub-contractors, Sub-consultants, Service providers, Suppliers, Agents personnel, permit the PPRA or any other appropriate authority appointed by Government of Kenya to inspect<sup>2</sup> all accounts, records and other documents relating to the procurement process, selection and/or contract execution, and to have them audited by auditors appointed by the PPRA or any other appropriate authority appointed by Government of Kenya; and
  - f) Pursuant to Section 62 of the above Act, requires Applicants/Tenderers to submit along with their Applications/Tenders/Proposals a “Self-Declaration Form” as included in the procurement document declaring that they and all parties involved in the procurement process and contract execution have not engaged/will not engage in any corrupt or fraudulent practices.

---

<sup>1</sup>For the avoidance of doubt, a party's ineligibility to be awarded a contract shall include, without limitation, (i) applying for pre-qualification, expressing interest in a consultancy, and tendering, either directly or as a nominated sub-contractor, nominated consultant, nominated manufacturer or supplier, or nominated service provider, in respect of such contract, and (ii) entering into an addendum or amendment introducing a material modification to any existing contract.

<sup>2</sup> Inspections in this context usually are investigative (i.e., forensic) in nature. They involve fact-finding activities undertaken by the Investigating Authority or persons appointed by the Procuring Entity to address specific matters related to investigations/audits, such as evaluating the veracity of an allegation of possible Fraud and Corruption, through the appropriate mechanisms. Such activity includes but is not limited to: accessing and examining a firm's or individual's financial records and information, and making copies thereof as relevant; accessing and examining any other documents, data and information (whether in hard copy or electronic format) deemed relevant for the investigation/audit, and making copies thereof as relevant; interviewing staff and other relevant individuals; performing physical inspections and site visits; and obtaining third party verification of information.

**FORM OF TENDER SECURITY-[Option 1–Demand Bank Guarantee]**

**Beneficiary:** \_\_\_\_\_

**Request for Tenders No:**  
\_\_\_\_\_

**Date:** \_\_\_\_\_

**TENDER GUARANTEE No.:** \_\_\_\_\_

**Guarantor:** \_\_\_\_\_

1. We have been informed that \_\_\_\_\_ (here inafter called "the Applicant") has submitted or will submit to the Beneficiary its Tender (here inafter called" the Tender") for the execution of \_\_\_\_\_ under Request for Tenders No. \_\_\_\_\_ ("the ITT").
2. Furthermore, we understand that, according to the Beneficiary's conditions, Tenders must be supported by a Tender guarantee.
3. At the request of the Applicant, we, as Guarantor, hereby irrevocably undertake to pay the Beneficiary any sum or sums not exceeding in total an amount of \_\_\_\_\_ (\_\_\_\_\_) upon receipt by us of the Beneficiary's complying demand, supported by the Beneficiary's statement, whether in the demand itself or a separate signed document accompanying or identifying the demand, stating that either the Applicant:
  - (a) has withdrawn its Tender during the period of Tender validity set forth in the Applicant's Letter of Tender ("the Tender Validity Period"), or any extension thereto provided by the Applicant; or
  - b) having been notified of the acceptance of its Tender by the Beneficiary during the Tender Validity Period or any extension there to provided by the Applicant, (i) has failed to execute the contract agreement, or (ii) has failed to furnish the Performance.
4. This guarantee will expire: (a) if the Applicant is the successful Tenderer, upon our receipt of copies of the contract agreement signed by the Applicant and the Performance Security and, or (b) if the Applicant is not the successful Tenderer, upon the earlier of (i) our receipt of a copy of the Beneficiary's notification to the Applicant of the results of the Tendering process; or (ii) thirty days after the end of the Tender Validity Period.
5. Consequently, any demand for payment under this guarantee must be received by us at the office indicated above on or before that date.

\_\_\_\_\_  
*[signature(s)]*

***Note: All italicized text is for use in preparing this form and shall be deleted from the final product.***

**FORMAT OF TENDER SECURITY [Option 2–Insurance Guarantee]**

**TENDER GUARANTEE No.:** \_\_\_\_\_

1. Whereas ..... [*Name of the tenderer*] (hereinafter called “the tenderer”) has submitted its tender dated ..... [*Date of submission of tender*] for the.....[*Name and/or description of the tender*] (hereinafter called “the Tender”) for the execution of \_\_\_\_\_ under Request for Tenders No. \_\_\_\_\_ (“the ITT”).
2. KNOW ALL PEOPLE by these presents that WE ..... of.....[**Name of Insurance Company**] having our registered office at ..... (hereinafter called “the Guarantor”), are bound unto ..... [*Name of Procuring Entity*] (hereinafter called “the Procuring Entity”) in the sum of ..... (Currency and guarantee amount) for which payment well and truly to be made to the said Procuring Entity, the Guarantor binds itself, its successors and assigns, jointly and severally, firmly by these presents.

Sealed with the Common Seal of the said Guarantor this \_\_\_day of \_\_\_\_\_20 \_\_.

3. NOW, THEREFORE, THE CONDITION OF THIS OBLIGATION is such that if the Applicant:
  - a) has withdrawn its Tender during the period of Tender validity set forth in the Principal's Letter of Tender (“the Tender Validity Period”), or any extension thereto provided by the Principal; or
  - b) having been notified of the acceptance of its Tender by the Procuring Entity during the Tender Validity Period or any extension thereto provided by the Principal; (i) failed to execute the Contract agreement; or (ii) has failed to furnish the Performance Security, in accordance with the Instructions to tenderers (“ITT”) of the Procuring Entity's Tendering document.

then the guarantee undertakes to immediately pay to the Procuring Entity up to the above amount upon receipt of the Procuring Entity's first written demand, without the Procuring Entity having to substantiate its demand, provided that in its demand the Procuring Entity shall state that the demand arises from the occurrence of any of the above events, specifying which event(s) has occurred.

4. This guarantee will expire: (a) if the Applicant is the successful Tenderer, upon our receipt of copies of the contract agreement signed by the Applicant and the Performance Security and, or (b) if the Applicant is not the successful Tenderer, upon the earlier of (i) our receipt of a copy of the Beneficiary's notification to the Applicant of the results of the Tendering process; or (ii) twenty-eight days after the end of the Tender Validity Period.
5. Consequently, any demand for payment under this guarantee must be received by us at the office indicated above on or before that date.

\_\_\_\_\_  
[Date]  
\_\_\_\_\_  
[Witness]

\_\_\_\_\_  
[Signature of the Guarantor]  
\_\_\_\_\_  
[Seal]

**Note: All italicized text is for use in preparing this form and shall be deleted from the final product.**

**TENDER-SECURING DECLARATION FORM**

*[The Bidder shall complete this Form in accordance with the instructions indicated]*

Date.....*[insert date (as day, month and year) of Tender Submission]*

Tender No..... *[insert number of tendering process]*

To:..... *[insert complete name of Purchaser]* I/We, the undersigned, declare that:

- 1. I/We understand that, according to your conditions, bids must be supported by a Tender-Securing Declaration.
- 2. I/We accept that I/we will automatically be suspended from being eligible for tendering in any contract with the Purchaser for the period of time of *[insert number of months or years]* starting on *[insert date]*, if we are in breach of our obligation(s) under the bid conditions, because we – (a) have withdrawn our tender during the period of tender validity specified by us in the Tendering Data Sheet; or (b) having been notified of the acceptance of our Bid by the Purchaser during the period of bid validity, (i) fail or refuse to execute the Contract, if required, or (ii) fail or refuse to furnish the Performance Security, in accordance with the instructions to tenders.
- 3. I/We understand that this Tender Securing Declaration shall expire if we are not the successful Tenderer(s), upon the earlier of:
  - a) our receipt of a copy of your notification of the name of the successful Tenderer; or
  - b) thirty days after the expiration of our Tender.
- 4. I/We understand that if I am/we are/in a Joint Venture, the Tender Securing Declaration must be in the name of the Joint Venture that submits the bid, and the Joint Venture has not been legally constituted at the time of bidding, the Tender Securing Declaration shall be in the names of all future partners as named in the letter of intent.

Signed.....Capacity / title (director

or partner or sole proprietor, etc.) ..... Name:

..... Duly authorized to sign the bid

for and on behalf of: *[insert complete name of Tenderer]*

Dated on ..... day of.....*[Insert date of signing]* Seal or stamp

## Appendix to Tender

### Schedule of Currency requirements

Summary of currencies of the Tender for \_\_\_\_\_ *[insert name of Section of the Works]*

<i>Name of currency</i>	<i>Amounts payable</i>
Local currency: _____	
Foreign currency #1: _____	
Foreign currency #2: _____	
Foreign currency #3: _____	
Provisional sums expressed in local currency	[To be entered by the Procuring Entity]

---

## **PART II - WORK REQUIREMENTS**

---



## SECTION V - DRAWINGS

A list of drawings should be inserted here. The actual drawings including Site plans should be annexed in a separate booklet.

## SECTION VI - SPECIFICATIONS

Notes for preparing Specifications

1. Specifications must be drafted to present a clear and precise statement of the required standards of materials, and workmanship for tenderers to respond realistically and competitively to the requirements of the Procuring Entity and ensure responsiveness of tenders. The Specifications should require that all materials, plant, and other supplies to be permanently incorporated in the Works be new, unused, of the most recent or current models, and incorporating all recent improvements in design and materials unless provided otherwise in the Contract. Where the Contractor is responsible for the design of any part of the permanent Works, the extent of his obligations must be stated.
  2. Specifications from previous similar projects are useful and may not be necessary to re-write specifications for every Works Contract.
  3. There are considerable advantages in standardizing **General Specifications** for repetitive Works in recognized public sectors, such as highways, urban housing, irrigation and water supply. The General Specifications should cover all classes of workmanship, materials and equipment commonly involved in constructions, although not necessarily to be used in a particular works contract. Deletions or addenda should then adapt the General Specifications to the particular Works.
  4. Care must be taken in drafting Specifications to ensure they are not restrictive. In the Specifications of standards for materials, plant and workmanship, existing Kenya Standards should be used as much as possible, otherwise recognized international standards may also be used.
  5. The Procuring Entity should decide whether technical solutions to specified parts of the Works are to be permitted. Alternatives are appropriate in cases where obvious (and potentially less costly) alternatives are possible to the technical solutions indicated in tender documents for certain elements of the Works, taking into consideration the comparative specialized advantage of potential tenderers.
  6. The Procuring Entity should provide a description of the selected parts of the Works with appropriate reference to Drawings, Specifications, Bills of Quantities, and Design or Performance criteria, stating that the alternative solutions shall be at least structurally and functionally equivalent to the basic design parameters and Specifications.
1. Such alternative solutions shall be accompanied by all information necessary for a complete evaluation by the Procuring Entity, including drawings, design calculations, technical specifications, breakdown of prices, proposed construction methodology, and other relevant details. Technical alternatives permitted in this manner shall be considered by the Procuring Entity each on its own merits and independently of whether the tenderer has priced the item as described in the Procuring Entity's design included with the tender documents.



## **SECTION VII- BILLS OF QUANTITIES**

### **1. Objectives**

The objectives of the Bill of Quantities are:

- a) to provide sufficient information on the quantities of Works to be performed to enable tenders to be prepared efficiently and accurately; and
- b) when a Contract has been entered into, to provide a priced Bill of Quantities for use in the periodic valuation of Works executed.

In order to attain these objectives, Works should be itemized in the Bill of Quantities in sufficient detail to distinguish between the different classes of Works, or between Works of the same nature carried out in different locations or in other circumstances which may give rise to different considerations of cost. Consistent with these requirements, the layout and contents of the Bill of Quantities should be as simple and brief as possible.

### **2. Day work Schedule**

A Day work Schedule should be included only if the probability of unforeseen work, outside the items included in the Bill of Quantities, is high. To facilitate checking by the Procuring Entity of the realism of rates quoted by the Tenderers, the Day work Schedule should normally comprise the following:

- a) A list of the various classes of labor, materials, and Constructional Plant for which basic day work rates or prices are to be inserted by the Tenderer, together with a statement of the conditions under which the Contractor shall be paid for work executed on a day work basis.
- b) Nominal quantities for each item of day work, to be priced by each Tenderer at day work rates as Tender. The rate to be entered by the Tenderer against each basic day work item should include the Contractor's profit, overheads, supervision, and other charges.

### **3. Provisional Sums**

A general provision for physical contingencies (quantity overruns) may be made by including a provisional sum in the Summary Bill of Quantities. Similarly, a contingency allowance for possible price increases should be provided as a provisional sum in the Summary priced Bill of Quantities. The inclusion of such provisional sums often facilitates budgetary approval by avoiding the need to request periodic supplementary approvals as the future need arises. Where such provisional sums or contingency allowances are used, the Special Conditions of Contract should state the manner in which they shall be used, and under whose authority (usually the Project Manager's).

The estimated cost of specialized work to be carried out, or of special goods to be supplied, by other contractors should be indicated in the relevant part of the Bill of Quantities as a particular provisional sum with an appropriate brief description. A separate procurement procedure is normally carried out by the Procuring Entity to select such specialized contractors. To provide an element of competition among the Tenderers in respect of any facilities, amenities, attendance, etc., to be provided by the successful Tenderer as prime Contractor for the use and convenience of the specialist contractors, each related provisional sum should be followed by an item in the Bill of Quantities inviting the Tenderer to quote a sum for such amenities, facilities, attendance, etc.

These Notes for Preparing a Bill of Quantities are intended only as information for the Procuring Entity or the person drafting the tendering document. They should not be included in the final tendering document.

### **4. The Bills of Quantities**

The Bills of Quantities should be divided generally into the following sections:

- a) Preambles
- b) Preliminary items
- c) Work Items
- c) Daywork Schedule; and
- d) Provisional items
- e) Summary.

5. The Summary to the Bills of Quantities will take this form or some other form but including these items.

<b>SUMMARY ITEMS</b>	<i>Page</i>	<i>Amount</i>
Bill No. 1: Preliminary Items		
Bill No. 2: Work Items		
Bill No 3: Daywork Summary		
Bill No 4: Provisional Sums		
Subtotal of Bills No 1-4		
Allow for any Discounts <sup>i</sup>		
<b>TOTAL TENDER PRICE Carried forward to Form of Tender</b>		

---

**PART III - CONDITIONS OF CONTRACT  
AND CONTRACT FORMS**

---

## SECTION VIII - GENERAL CONDITIONS OF CONTRACT

These General Conditions of Contract (GCC), read in conjunction with the Special Conditions of Contract (SCC) and other documents listed therein, should be a complete document expressing fairly the rights and obligations of both parties.

These General Conditions of Contract have been developed on the basis of considerable international experience in the drafting and management of contracts, bearing in mind a trend in the construction industry towards simpler, more straightforward language.

The GCC can be used for both smaller admeasurement contracts and lump sum contracts.

### General Conditions of Contract

#### A. General

##### 1. Definitions

1.1 Bold face type is used to identify defined terms.

- a) **The Accepted Contract Amount** means the amount accepted in the Letter of Acceptance for the execution and completion of the Works and the remedying of any defects.
- b) **The Activity Schedule** is a schedule of the activities comprising the construction, installation, testing, and commissioning of the Works in a lump sum contract. It includes a lump sum price for each activity, which is used for valuations and for assessing the effects of Variations and Compensation Events.
- c) **The Adjudicator** is the person appointed jointly by the Procuring Entity and the Contractor to resolve disputes in the first instance, as provided for in GCC 23.
- d) **Bill of Quantities** means the priced and completed Bill of Quantities forming part of the Bid.
- e) **Compensation Events** are those defined in GCC Clause 42 hereunder.
- f) **The Completion Date** is the date of completion of the Works as certified by the Project Manager, in accordance with GCC Sub-Clause 53.1.
- g) **The Contract** is the Contract between the Procuring Entity and the Contractor to execute, complete, and maintain the Works. It consists of the documents listed in GCC Sub-Clause 2.3 below.
- h) **The Contractor** is the party whose Bid to carry out the Works has been accepted by the Procuring Entity.
- i) **The Contractor's Bid** is the completed bidding document submitted by the Contractor to the Procuring Entity.
- j) **The Contract Price** is the Accepted Contract Amount stated in the Letter of Acceptance and thereafter as adjusted in accordance with the Contract.
- k) **Days** are calendar days; months are calendar months.
- l) **Day works** are varied work inputs subject to payment on a time basis for the Contractor's employees and Equipment, in addition to payments for associated Materials and Plant.
- m) **A Defect** is any part of the Works not completed in accordance with the Contract.
- n) **The Defects Liability Certificate** is the certificate issued by Project Manager upon correction of defects by the Contractor.
- o) **The Defects Liability Period** is the period **named in the SCC** pursuant to Sub-Clause 34.1 and calculated from the Completion Date.
- p) **Drawings** means the drawings of the Works, as included in the Contract, and any additional and modified drawings issued by (or on behalf of) the Procuring Entity in accordance with the Contract, include calculations and other information provided or approved by the Project Manager for the execution of the Contract.
- q) **The Procuring Entity** is the party who employs the Contractor to carry out the Works, **as specified in the SCC**, who is also the Procuring Entity.
- r) **Equipment** is the Contractor's machinery and vehicles brought temporarily to the Site to construct the Works.

- s) **“In writing” or “written”** means hand-written, type-written, printed or electronically made, and resulting in a permanent record;
- t) The Initial Contract Price is the Contract Price listed in the Procuring Entity's Letter of Acceptance.
- u) **The Intended Completion Date** is the date on which it is intended that the Contractor shall complete the Works. The Intended Completion Date is **specified in the SCC**. The Intended Completion Date may be revised only by the Project Manager by issuing an extension of time or an acceleration order.
- v) **Materials** are all supplies, including consumables, used by the Contractor for incorporation in the Works.
- w) **Plant** is any integral part of the Works that shall have a mechanical, electrical, chemical, or biological function.
- x) **The Project Manager** is the person **named in the SCC** (or any other competent person appointed by the Procuring Entity and notified to the Contractor, to act in replacement of the Project Manager) who is responsible for supervising the execution of the Works and administering the Contract.
- y) **SCC** means Special Conditions of Contract.
- z) **The Site** is the area of the works as **defined as such in the SCC**.
- aa) **Site Investigation Reports** are those that were included in the bidding document and are factual and interpretative reports about the surface and subsurface conditions at the Site.
- ab) **Specification** means the Specification of the Works included in the Contract and any modification or addition made or approved by the Project Manager.
- ac) **The Start Date** is **given in the SCC**. It is the latest date when the Contractor shall commence execution of the Works. It does not necessarily coincide with any of the Site Possession Dates.
- ad) **A Subcontractor** is a person or corporate body who has a Contract with the Contractor to carry out a part of the work in the Contract, which includes work on the Site.
- ae) **Temporary Works** are works designed, constructed, installed, and removed by the Contractor that are needed for construction or installation of the Works.
- af) **A Variation** is an instruction given by the Project Manager which varies the Works.
- ag) **The Works** are what the Contract requires the Contractor to construct, install, and turn over to the Procuring Entity, **as defined in the SCC**.

## 2. Interpretation

- 21 In interpreting these GCC, words indicating one gender include all genders. Words indicating the singular also include the plural and words indicating the plural also include the singular. Headings have no significance. Words have their normal meaning under the language of the Contract unless specifically defined. The Project Manager shall provide instructions clarifying queries about these GCC.
- 22 If sectional completion is specified in the SCC, references in the GCC to the Works, the Completion Date, and the Intended Completion Date apply to any Section of the Works (other than references to the Completion Date and Intended Completion Date for the whole of the Works).
- 23 The documents forming the Contract shall be interpreted in the following order of priority:
  - a) Agreement,
  - b) Letter of Acceptance,
  - c) Contractor's Bid,
  - d) Special Conditions of Contract,
  - e) General Conditions of Contract, including Appendices,
  - f) Specifications,
  - g) Drawings,
  - h) Bill of Quantities<sup>6</sup>, and
  - i) any other document **listed in the SCC** as forming part of the Contract.

<sup>6</sup>In lump sum contracts, delete “Bill of Quantities” and replace with “Activity Schedule.”

### 3. Language and Law

- 31 The language of the Contract is English Language and the law governing the Contract are the Laws of Kenya.
- 32 Throughout the execution of the Contract, the Contractor shall comply with the import of goods and services prohibitions in the Procuring Entity's Country when
  - a) as a matter of law or official regulations, Kenya prohibits commercial relations with that country; or
  - b) by an act of compliance with a decision of the United Nations Security Council taken under Chapter VII of the Charter of the United Nations, Kenya prohibits any import of goods from that country or any payments to any country, person, or entity in that country.

### 4. Project Manager's Decisions

- 41 Except where otherwise specifically stated, the Project Manager shall decide contractual matters between the Procuring Entity and the Contractor in the role representing the Procuring Entity.

### 5. Delegation

- 51 Otherwise **specified in the SCC**, the Project Manager may delegate any of his duties and responsibilities to other people, except to the Adjudicator, after notifying the Contractor, and may revoke any delegation after notifying the Contractor.

### 6. Communications

- 61 Communications between parties that are referred to in the Conditions shall be effective only when in writing. A notice shall be effective only when it is delivered.

### 7. Subcontracting

- 71 The Contractor may subcontract with the approval of the Project Manager, but may not assign the Contract without the approval of the Procuring Entity in writing. Subcontracting shall not alter the Contractor's obligations.

### 8. Other Contractors

- 81 The Contractor shall cooperate and share the Site with other contractors, public authorities, utilities, and the Procuring Entity between the dates given in the Schedule of Other Contractors, as **referred to in the SCC**. The Contractor shall also provide facilities and services for them as described in the Schedule. The Procuring Entity may modify the Schedule of Other Contractors, and shall notify the Contractor of any such modification.

### 9. Personnel and Equipment

- 91 The Contractor shall employ the key personnel and use the equipment identified in its Bid, to carry out the Works or other personnel and equipment approved by the Project Manager. The Project Manager shall approve any proposed replacement of key personnel and equipment only if their relevant qualifications or characteristics are substantially equal to or better than those proposed in the Bid.
- 92 If the Project Manager asks the Contractor to remove a person who is a member of the Contractor's staff or work force, stating the reasons, the Contractor shall ensure that the person leaves the Site within seven days and has no further connection with the work in the Contract.
- 93 If the Procuring Entity, Project Manager or Contractor determines, that any employee of the Contractor be determined to have engaged in Fraud and Corruption during the execution of the Works, then that employee shall be removed in accordance with Clause 9.2 above.

### 10. Procuring Entity's and Contractor's Risks

- 101 The Procuring Entity carries the risks which this Contract states are Procuring Entity's risks, and the Contractor carries the risks which this Contract states are Contractor's risks.

## 11. Procuring Entity's Risks

- 11.1 From the Start Date until the Defects Liability Certificate has been issued, the following are Procuring Entity's risks:
- a) The risk of personal injury, death, or loss of or damage to property (excluding the Works, Plant, Materials, and Equipment), which are due to
    - i) use or occupation of the Site by the Works or for the purpose of the Works, which is the unavoidable result of the Works
    - ii) negligence, breach of statutory duty, or interference with any legal right by the Procuring Entity or by any person employed by or contracted to him except the Contractor.
  - b) The risk of damage to the Works, Plant, Materials, and Equipment to the extent that it is due to a fault of the Procuring Entity or in the Procuring Entity's design, or due to war or radioactive contamination directly affecting the country where the Works are to be executed.
- 11.2 From the Completion Date until the Defects Liability Certificate has been issued, the risk of loss of or damage to the Works, Plant, and Materials is a Procuring Entity's risk except loss or damage due to
- aa) a Defect which existed on the Completion Date,
  - ab) an event occurring before the Completion Date, which was not itself a Procuring Entity's risk, or
  - ac) the activities of the Contractor on the Site after the Completion Date.

## 12. Contractor's Risks

- 12.1 From the Starting Date until the Defects Liability Certificate has been issued, the risks of personal injury, death, and loss of or damage to property (including, without limitation, the Works, Plant, Materials, and Equipment) which are not Procuring Entity's risks are Contractor's risks.

## 13. Insurance

- 13.1 The Contractor shall provide, in the joint names of the Procuring Entity and the Contractor, insurance cover from the Start Date to the end of the Defects Liability Period, in the amounts and deductibles **stated in the SCC** for the following events which are due to the Contractor's risks:
- a) loss of or damage to the Works, Plant, and Materials;
  - b) loss of or damage to Equipment;
  - c) loss of or damage to property (except the Works, Plant, Materials, and Equipment) in connection with the Contract; and
  - d) personal injury or death.
- 13.2 Policies and certificates for insurance shall be delivered by the Contractor to the Project Manager for the Project Manager's approval before the Start Date. All such insurance shall provide for compensation to be payable in the types and proportions of currencies required to rectify the loss or damage incurred.
- 13.3 If the Contractor does not provide any of the policies and certificates required, the Procuring Entity may effect the insurance which the Contractor should have provided and recover the premiums the Procuring Entity has paid from payments otherwise due to the Contractor or, if no payment is due, the payment of the premiums shall be a debt due.
- 13.4 Alterations to the terms of an insurance shall not be made without the approval of the Project Manager.
- 13.5 Both parties shall comply with any conditions of the insurance policies.

## 14. Site Data

- 14.1 The Contractor shall be deemed to have examined any Site Data **referred to in the SCC**, supplemented by any information available to the Contractor.

## 15. Contractor to Construct the Works

- 15.1 The Contractor shall construct and install the Works in accordance with the Specifications and Drawings.

## **16. The Works to Be Completed by the Intended Completion Date**

161 The Contractor may commence execution of the Works on the Start Date and shall carry out the Works in accordance with the Program submitted by the Contractor, as updated with the approval of the Project Manager, and complete them by the Intended Completion Date.

## **17. Approval by the Project Manager**

171 The Contractor shall submit Specifications and Drawings showing the proposed Temporary Works to the Project Manager, for his approval.

172 The Contractor shall be responsible for design of Temporary Works.

173 The Project Manager's approval shall not alter the Contractor's responsibility for design of the Temporary Works.

174 The Contractor shall obtain approval of third parties to the design of the Temporary Works, where required.

175 All Drawings prepared by the Contractor for the execution of the temporary or permanent Works, are subject to prior approval by the Project Manager before this use.

## **18. Safety**

181 The Contractor shall be responsible for the safety of all activities on the Site.

## **19. Discoveries**

191 Anything of historical or other interest or of significant value unexpectedly discovered on the Site shall be the property of the Procuring Entity. The Contractor shall notify the Project Manager of such discoveries and carry out the Project Manager's instructions for dealing with them.

## **20. Possession of the Site**

201 The Procuring Entity shall give possession of all parts of the Site to the Contractor. If possession of a part is not given by the date **stated in the SCC**, the Procuring Entity shall be deemed to have delayed the start of the relevant activities, and this shall be a Compensation Event.

## **21. Access to the Site**

211 The Contractor shall allow the Project Manager and any person authorized by the Project Manager access to the Site and to any place where work in connection with the Contract is being carried out or is intended to be carried out.

## **22. Instructions, Inspections and Audits**

221 The Contractor shall carry out all instructions of the Project Manager which comply with the applicable laws where the Site is located.

222 The Contractor shall keep, and shall make all reasonable efforts to cause its Subcontractors and sub-consultants to keep, accurate and systematic accounts and records in respect of the Works in such form and details as will clearly identify relevant time changes and costs.

223 The Contractor shall permit and shall cause its subcontractors and sub-consultants to permit, the Procuring Entity and/or persons appointed by the Public Procurement Regulatory Authority to inspect the Site and/or the accounts and records relating to the procurement process, selection and/or contract execution, and to have such accounts and records audited by auditors appointed by the Public Procurement Regulatory Authority. The Contractor's and its Subcontractors' and sub-consultants' attention is drawn to Sub-Clause 25.1 (Fraud and Corruption) which provides, inter alia, that acts intended to materially impede the exercise of the Public Procurement Regulatory Authority's inspection and audit rights constitute a prohibited practice subject to contract termination (as well as to a determination of ineligibility pursuant to the Public Procurement Regulatory Authority's prevailing sanctions procedures).

## 23. Appointment of the Adjudicator

- 23.1 The Adjudicator shall be appointed jointly by the Procuring Entity and the Contractor, at the time of the Procuring Entity's issuance of the Letter of Acceptance. If, in the Letter of Acceptance, the Procuring Entity does not agree on the appointment of the Adjudicator, the Procuring Entity will request the Appointing Authority designated in the SCC, to appoint the Adjudicator within 14 days of receipt of such request.
- 23.2 Should the Adjudicator resign or die, or should the Procuring Entity and the Contractor agree that the Adjudicator is not functioning in accordance with the provisions of the Contract, a new Adjudicator shall be jointly appointed by the Procuring Entity and the Contractor. In case of disagreement between the Procuring Entity and the Contractor, within 30 days, the Adjudicator shall be designated by the Appointing Authority designated in the SCC at the request of either party, within 14 days of receipt of such request.

## 24. Settlement of Claims and Disputes

### 24.1 Contractor's Claims

- 24.1.1 If the Contractor considers itself to be entitled to any extension of the Time for Completion and/or any additional payment, under any Clause of these Conditions or otherwise in connection with the Contract, the Contractor shall give Notice to the Project Manager, describing the event or circumstance giving rise to the claim. The notice shall be given as soon as practicable, and not later than 30 days after the Contractor became aware, or should have become aware, of the event or circumstance.
- 24.1.2 If the Contractor fails to give notice of a claim within such period of 30 days, the Time for Completion shall not be extended, the Contractor shall not be entitled to additional payment, and the Procuring Entity shall be discharged from all liability in connection with the claim. Otherwise, the following provisions of this Sub- Clause shall apply.
- 24.1.3 The Contractor shall also submit any other notices which are required by the Contract, and supporting particulars for the claim, all as relevant to such event or circumstance.
- 24.1.4 The Contractor shall keep such contemporary records as may be necessary to substantiate any claim, either on the Site or at another location acceptable to the Project Manager. Without admitting the Procuring Entity's liability, the Project Manager may, after receiving any notice under this Sub-Clause, monitor the record- keeping and/or instruct the Contractor to keep further contemporary records. The Contractor shall permit the Project Manager to inspect all these records, and shall (if instructed) submit copies to the Project Manager.
- 24.1.5 Within 42 days after the Contractor became aware (or should have become aware) of the event or circumstance giving rise to the claim, or within such other period as may be proposed by the Contractor and approved by the Project Manager, the Contractor shall send to the Project Manager a fully detailed claim which includes full supporting particulars of the basis of the claim and of the extension of time and/or additional payment claimed. If the event or circumstance giving rise to the claim has a continuing effect:
- a) this fully detailed claim shall be considered as interim;
  - b) the Contractor shall send further interim claims at monthly intervals, giving the accumulated delay and/or amount claimed, and such further particulars as the Project Manager may reasonably require; and
  - c) the Contractor shall send a final claim within 30 days after the end of the effects resulting from the event or circumstance, or within such other period as may be proposed by the Contractor and approved by the Project Manager.
- 24.1.6 Within 42 days after receiving a Notice of a claim or any further particulars supporting a previous claim, or within such other period as may be proposed by the Project Manager and approved by the Contractor, the Project Manager shall respond with approval, or with disapproval and detailed comments. He may also request any necessary further particulars, but shall nevertheless give his response on the principles of the claim within the above defined time period.
- 24.1.7 Within the above defined period of 42 days, the Project Manager shall proceed in accordance with Sub-Clause
- 24.1.8 [Determinations] to agree or determine (i) the extension (if any) of the Time for Completion (before or after its expiry) in accordance with Sub-Clause 8.4 [Extension of Time for Completion], and/or (ii) the

additional payment (if any) to which the Contractor is entitled under the Contract.

24.1.9 Each Payment Certificate shall include such additional payment for any claim as has been reasonably substantiated as due under the relevant provision of the Contract. Unless and until the particulars supplied are sufficient to substantiate the whole of the claim, the Contractor shall only be entitled to payment for such part of the claim as he has been able to substantiate.

24.1.10 If the Project Manager does not respond within the timeframe defined in this Clause, either Party may consider that the claim is rejected by the Project Manager and any of the Parties may refer to Arbitration in accordance with Sub-Clause 24.4 [Arbitration].

24.1.11 The requirements of this Sub-Clause are in addition to those of any other Sub-Clause which may apply to a claim. If the Contractor fails to comply with this or another Sub-Clause in relation to any claim, any extension of time and/or additional payment shall take account of the extent (if any) to which the failure has prevented or prejudiced proper investigation of the claim, unless the claim is excluded under the second paragraph of this Sub-Clause 24.3.

## **242 Amicable Settlement**

24.2.1 Where a notice of a claim has been given, both Parties shall attempt to settle the dispute amicably before the commencement of arbitration. However, unless both Parties agree otherwise, the Party giving a notice of a claim in accordance with Sub-Clause 24.1 above should move to commence arbitration after the fifty-sixth day from the day on which a notice of a claim was given, even if no attempt at an amicable settlement has been made.

## **243 Matters that may be referred to arbitration**

24.3.1 Notwithstanding anything stated herein the following matters may be referred to arbitration before the practical completion of the Works or abandonment of the Works or termination of the Contract by either party:

- a) The appointment of a replacement Project Manager upon the said person ceasing to act.
- b) Whether or not the issue of an instruction by the Project Manager is empowered by these Conditions.
- c) Whether or not a certificate has been improperly withheld or is not in accordance with these Conditions.
- e) Any dispute arising in respect of war risks or war damage.
- f) All other matters shall only be referred to arbitration after the completion or alleged completion of the Works or termination or alleged termination of the Contract, unless the Procuring Entity and the Contractor agree otherwise in writing.

## **244 Arbitration**

24.4.1 Any claim or dispute between the Parties arising out of or in connection with the Contract not settled amicably in accordance with Sub-Clause 24.3 shall be finally settled by arbitration.

24.4.2 No arbitration proceedings shall be commenced on any claim or dispute where notice of a claim or dispute has not been given by the applying party within ninety days of the occurrence or discovery of the matter or issue giving rise to the dispute.

24.4.3 Notwithstanding the issue of a notice as stated above, the arbitration of such a claim or dispute shall not commence unless an attempt has in the first instance been made by the parties to settle such claim or dispute amicably with or without the assistance of third parties. Proof of such attempt shall be required.

24.4.4 The Arbitrator shall, without prejudice to the generality of his powers, have powers to direct such measurements, computations, tests or valuations as may in his opinion be desirable in order to determine the rights of the parties and assess and award any sums which ought to have been the subject of or included in any certificate.

24.4.5 The Arbitrator shall, without prejudice to the generality of his powers, have powers to open up, review and revise any certificate, opinion, decision, requirement or notice and to determine all matters in dispute which shall be submitted to him in the same manner as if no such certificate, opinion, decision requirement or notice had been given.

24.4.6 The arbitrators shall have full power to open up, review and revise any certificate, determination, instruction, opinion or valuation of the Project Manager, relevant to the dispute. Nothing shall disqualify representatives of the Parties and the Project Manager from being called as a witness and giving evidence before the arbitrators on any matter whatsoever relevant to the dispute.

24.4.7 Neither Party shall be limited in the proceedings before the arbitrators to the evidence, or to the reasons for dissatisfaction given in its Notice of Dissatisfaction.

24.4.8 Arbitration may be commenced prior to or after completion of the Works. The obligations of the Parties, and the Project Manager shall not be altered by reason of any arbitration being conducted during the progress of the Works.

24.4.9 The terms of the remuneration of each or all the members of Arbitration shall be mutually agreed upon by the

Parties when agreeing the terms of appointment. Each Party shall be responsible for paying one-half of this remuneration.

#### **245 Arbitration with National Contractors**

24.5.1 If the Contract is with national contractors, arbitration proceedings will be conducted in accordance with the Arbitration Laws of Kenya. In case of any claim or dispute, such claim or dispute shall be notified in writing by either party to the other with a request to submit it to arbitration and to concur in the appointment of an Arbitrator within thirty days of the notice. The dispute shall be referred to the arbitration and final decision of a person to be agreed between the parties. Failing agreement to concur in the appointment of an Arbitrator, the Arbitrator shall be appointed, on the request of the applying party, by the Chairman or Vice Chairman of any of the following professional institutions;

- i) Architectural Association of Kenya
- ii) Institute of Quantity Surveyors of Kenya
- iii) Association of Consulting Engineers of Kenya
- iv) Chartered Institute of Arbitrators (Kenya Branch)
- v) Institution of Engineers of Kenya

24.5.2 The institution written to first by the aggrieved party shall take precedence over all other institutions.

#### **246 Alternative Arbitration Proceedings**

24.6.1 Alternatively, the Parties may refer the matter to the Nairobi Centre for International Arbitration (NCIA) which offers a neutral venue for the conduct of national and international arbitration with commitment to providing institutional support to the arbitral process.

#### **247 Failure to Comply with Arbitrator's Decision**

24.7.1 The award of such Arbitrator shall be final and binding upon the parties.

24.7.2 In the event that a Party fails to comply with a final and binding Arbitrator's decision, then the other Party may, without prejudice to any other rights it may have, refer the matter to a competent court of law.

#### **248 Contract operations to continue**

24.8.1 Notwithstanding any reference to arbitration herein,

- a) the parties shall continue to perform their respective obligations under the Contract unless they otherwise agree; and
- b) the Procuring Entity shall pay the Contractor any monies due the Contractor.

### **25. Fraud and Corruption**

25.1 The Government requires compliance with the country's Anti-Corruption laws and its prevailing sanctions policies and procedures as set forth in the Constitution of Kenya and its Statutes.

25.2 The Procuring Entity requires the Contractor to disclose any commissions or fees that may have been paid or are to be paid to agents or any other party with respect to the bidding process or execution of the Contract. The information disclosed must include at least the name and address of the agent or other party, the amount and currency, and the purpose of the commission, gratuity or fee.

## **B. Time Control**

### **26. Program**

26.1 Within the time stated in the SCC, after the date of the Letter of Acceptance, the Contractor shall submit to the Project Manager for approval a Program showing the general methods, arrangements, order, and timing for all the activities in the Works. In the case of a lump sum contract, the activities in the Program shall be consistent with those in the Activity Schedule.

26.2 An update of the Program shall be a program showing the actual progress achieved on each activity and the effect of the progress achieved on the timing of the remaining work, including any changes to the sequence of the activities.

26.3 The Contractor shall submit to the Project Manager for approval an updated Program at intervals no longer than the period stated in the SCC. If the Contractor does not submit an updated Program within this period, the Project Manager may withhold the amount stated in the SCC from the next payment certificate and

continue to withhold this amount until the next payment after the date on which the overdue Program has been submitted. In the case of a lump sum contract, the Contractor shall provide an updated Activity Schedule within 14 days of being instructed to by the Project Manager.

264 The Project Manager's approval of the Program shall not alter the Contractor's obligations. The Contractor may revise the Program and submit it to the Project Manager again at any time. A revised Program shall show the effect of Variations and Compensation Events.

## **27. Extension of the Intended Completion Date**

271 The Project Manager shall extend the Intended Completion Date if a Compensation Event occurs or a Variation is issued which makes it impossible for Completion to be achieved by the Intended Completion Date without the Contractor taking steps to accelerate the remaining work, which would cause the Contractor to incur additional cost.

272 The Project Manager shall decide whether and by how much to extend the Intended Completion Date within 21 days of the Contractor asking the Project Manager for a decision upon the effect of a Compensation Event or Variation and submitting full supporting information. If the Contractor has failed to give early warning of a delay or has failed to cooperate in dealing with a delay, the delay by this failure shall not be considered in assessing the new Intended Completion Date.

## **28. Acceleration**

281 When the Procuring Entity wants the Contractor to finish before the Intended Completion Date, the Project Manager shall obtain priced proposals for achieving the necessary acceleration from the Contractor. If the Procuring Entity accepts these proposals, the Intended Completion Date shall be adjusted accordingly and confirmed by both the Procuring Entity and the Contractor.

282 If the Contractor's priced proposals for an acceleration are accepted by the Procuring Entity, they are incorporated in the Contract Price and treated as a Variation.

## **29. Delays Ordered by the Project Manager**

291 The Project Manager may instruct the Contractor to delay the start or progress of any activity within the Works.

## **30. Management Meetings**

301 Either the Project Manager or the Contractor may require the other to attend a management meeting. The business of a management meeting shall be to review the plans for remaining work and to deal with matters raised in accordance with the early warning procedure.

302 The Project Manager shall record the business of management meetings and provide copies of the record to those attending the meeting and to the Procuring Entity. The responsibility of the parties for actions to be taken shall be decided by the Project Manager either at the management meeting or after the management meeting and stated in writing to all who attended the meeting.

## **31. Early Warning**

311 The Contractor shall warn the Project Manager at the earliest opportunity of specific likely future events or circumstances that may adversely affect the quality of the work, increase the Contract Price, or delay the execution of the Works. The Project Manager may require the Contractor to provide an estimate of the expected effect of the future event or circumstance on the Contract Price and Completion Date. The estimate shall be provided by the Contractor as soon as reasonably possible.

312 The Contractor shall cooperate with the Project Manager in making and considering proposals for how the effect of such an event or circumstance can be avoided or reduced by anyone involved in the work and in carrying out any resulting instruction of the Project Manager.

## **C. Quality Control**

### **32. Identifying Defects**

321 The Project Manager shall check the Contractor's work and notify the Contractor of any Defects that are found. Such checking shall not affect the Contractor's responsibilities. The Project Manager may instruct the Contractor to search for a Defect and to uncover and test any work that the Project Manager considers may have a Defect.

### 33. Tests

- 33.1 If the Project Manager instructs the Contractor to carry out a test not specified in the Specification to check whether any work has a Defect and the test shows that it does, the Contractor shall pay for the test and any samples. If there is no Defect, the test shall be a Compensation Event.

### 34. Correction of Defects

- 34.1 The Project Manager shall give notice to the Contractor of any Defects before the end of the Defects Liability Period, which begins at Completion, and is defined in the SCC. The Defects Liability Period shall be extended for as long as Defects remain to be corrected.
- 34.2 Every time notice of a Defect is given, the Contractor shall correct the notified Defect within the length of time specified by the Project Manager's notice.

### 35. Uncorrected Defects

- 35.1 If the Contractor has not corrected a Defect within the time specified in the Project Manager's notice, the Project Manager shall assess the cost of having the Defect corrected, and the Contractor shall pay this amount.

## D. Cost Control

### 36. Contract Price<sup>7</sup>

- 36.1 The Bill of Quantities shall contain priced items for the Works to be performed by the Contractor. The Bill of Quantities is used to calculate the Contract Price. The Contractor will be paid for the quantity of the work accomplished at the rate in the Bill of Quantities for each item.

### 37. Changes in the Contract Price<sup>8</sup>

- 37.1 If the final quantity of the work done differs from the quantity in the Bill of Quantities for the particular item by more than 25 percent, provided the change exceeds 1 percent of the Initial Contract Price, the Project Manager shall adjust the rate to allow for the change. The Project Manager shall not adjust rates from changes in quantities if thereby the Initial Contract Price is exceeded by more than 15 percent, except with the prior approval of the Procuring Entity.
- 37.2 If requested by the Project Manager, the Contractor shall provide the Project Manager with a detailed cost breakdown of any rate in the Bill of Quantities.

### 38. Variations

- 38.1 All Variations shall be included in updated Programs<sup>9</sup> produced by the Contractor.
- 38.2 The Contractor shall provide the Project Manager with a quotation for carrying out the Variation when requested to do so by the Project Manager. The Project Manager shall assess the quotation, which shall be given within seven (7) days of the request or within any longer period stated by the Project Manager and before the Variation is ordered.
- 38.3 If the Contractor's quotation is unreasonable, the Project Manager may order the Variation and make a change to the Contract Price, which shall be based on the Project Manager's own forecast of the effects of the Variation on the Contractor's costs.
- 38.4 If the Project Manager decides that the urgency of varying the work would prevent a quotation being given and considered without delaying the work, no quotation shall be given and the Variation shall be treated as a Compensation Event.

---

<sup>7</sup>In lump sum contracts, replace GCC Sub-Clauses 36.1 as follows:

36.1 The Contractor shall provide updated Activity Schedules within 14 days of being instructed to by the Project Manager. The Activity Schedule shall contain the priced activities for the Works to be performed by the Contractor. The Activity Schedule is used to monitor and control the performance of activities on which basis the Contractor will be paid. If payment for materials on site shall be made separately, the Contractor shall show delivery of Materials to the Site separately on the Activity Schedule.

<sup>8</sup>In lump sum contracts, replace entire GCC Clause 37 with new GCC Sub-Clause 37.1, as follows:

The Activity Schedule shall be amended by the Contractor to accommodate changes of Program or method of working made at the Contractor's own discretion. Prices in the Activity Schedules shall not be altered when the Contractor makes such changes to the Activity Schedule.

<sup>9</sup>In lump sum contracts, add "and Activity Schedules" after "Programs." <sup>10</sup>In lump sum contracts, delete this paragraph.

- 385 The Contractor shall not be entitled to additional payment for costs that could have been avoided by giving early warning
- 386 If the work in the Variation corresponds to an item description in the Bill of Quantities and if, in the opinion of the Project Manager, the quantity of work above the limit stated in Sub-Clause 39.1 or the timing of its execution do not cause the cost per unit of quantity to change, the rate in the Bill of Quantities shall be used to calculate the value of the Variation. If the cost per unit of quantity changes, or if the nature or timing of the work in the Variation does not correspond with items in the Bill of Quantities, the quotation by the Contractor shall be in the form of new rates for the relevant items of work
- 387 Value Engineering: The Contractor may prepare, at its own cost, a value engineering proposal at any time during the performance of the contract. The value engineering proposal shall, at a minimum, include the following;
- a) the proposed change(s), and a description of the difference to the existing contract requirements;
  - b) a full cost/benefit analysis of the proposed change(s) including a description and estimate of costs (including life cycle costs) the Procuring Entity may incur in implementing the value engineering proposal; and
  - c) a description of any effect(s) of the change on performance/functionality.
- 388 The Procuring Entity may accept the value engineering proposal if the proposal demonstrates benefits that:
- a) accelerate the contract completion period; or
  - b) reduce the Contract Price or the life cycle costs to the Procuring Entity; or
  - c) improve the quality, efficiency, safety or sustainability of the Facilities; or
  - d) yield any other benefits to the Procuring Entity, without compromising the functionality of the Works.
- 389 If the value engineering proposal is approved by the Procuring Entity and results in:
- a) a reduction of the Contract Price; the amount to be paid to the Contractor shall be the **percentage specified in the SCC** of the reduction in the Contract Price; or
  - b) an increase in the Contract Price; but results in a reduction in life cycle costs due to any benefit described in (a) to (d) above, the amount to be paid to the Contractor shall be the full increase in the Contract Price.

### 39. Cash Flow Forecasts

- 391 When the Program<sup>11</sup>, is updated, the Contractor shall provide the Project Manager with an updated cash flow forecast. The cash flow forecast shall include different currencies, as defined in the Contract, converted as necessary using the Contract exchange rates.

### 40. Payment Certificates

- 401 The Contractor shall submit to the Project Manager monthly statements of the estimated value of the work executed less the cumulative amount certified previously.
- 402 The Project Manager shall check the Contractor's monthly statement and certify the amount to be paid to the Contractor.
- 403 The value of work executed shall be determined by the Project Manager.
- 404 The value of work executed shall comprise the value of the quantities of work in the Bill of Quantities that have been completed<sup>12</sup>.
- 405 The value of work executed shall include the valuation of Variations and Compensation Events.
- 406 The Project Manager may exclude any item certified in a previous certificate or reduce the proportion of any item previously certified in any certificate in the light of later information.
- 407 Where the contract price is different from the corrected tender price, in order to ensure the contractor is not paid less or more relative to the contract price (which would be the tender price), payment valuation certificates and variation orders on omissions and additions valued based on rates in the Bill of Quantities or schedule of rates in the Tender, will be adjusted by a plus or minus percentage. The percentage already worked out during tender evaluation is worked out as follows:  $(\text{corrected tender price} - \text{tender price}) / \text{tender price} \times 100$ .

## 41. Payments

- 41.1 Payments shall be adjusted for deductions for advance payments and retention. The Procuring Entity shall pay the Contractor the amounts certified by the Project Manager within 30 days of the date of each certificate. If the Procuring Entity makes a late payment, the Contractor shall be paid interest on the late payment in the next payment. Interest shall be calculated from the date by which the payment should have been made up to the date when the late payment is made at the prevailing rate of interest for commercial borrowing for each of the currencies in which payments are made.
- 41.2 If an amount certified is increased in a later certificate or as a result of an award by the Adjudicator or an Arbitrator, the Contractor shall be paid interest upon the delayed payment as set out in this clause. Interest shall be calculated from the date upon which the increased amount would have been certified in the absence of dispute.
- 41.3 Unless otherwise stated, all payments and deductions shall be paid or charged in the proportions of currencies comprising the Contract Price.
- 41.4 Items of the Works for which no rate or price has been entered in shall not be paid for by the Procuring Entity and shall be deemed covered by other rates and prices in the Contract.

## 42. Compensation Events

42.1 The following shall be Compensation Events:

- d) The Procuring Entity does not give access to a part of the Site by the Site Possession Date pursuant to GCC Sub-Clause 20.1.
- e) The Procuring Entity modifies the Schedule of Other Contractors in a way that affects the work of the Contractor under the Contract.
- f) The Project Manager orders a delay or does not issue Drawings, Specifications, or instructions required for execution of the Works on time.
- g) The Project Manager instructs the Contractor to uncover or to carry out additional tests upon work, which is then found to have no Defects.
- h) The Project Manager unreasonably does not approve a subcontract to be let.
- i) Ground conditions are substantially more adverse than could reasonably have been assumed before issuance of the Letter of Acceptance from the information issued to bidders (including the Site Investigation Reports), from information available publicly and from a visual inspection of the Site.
- j) The Project Manager gives an instruction for dealing with an unforeseen condition, caused by the Procuring Entity, or additional work required for safety or other reasons.
- k) Other contractors, public authorities, utilities, or the Procuring Entity does not work within the dates and other constraints stated in the Contract, and they cause delay or extra cost to the Contractor.
- l) The advance payment is delayed.
- m) The effects on the Contractor of any of the Procuring Entity's Risks.
- n) The Project Manager unreasonably delays issuing a Certificate of Completion.

42.2 If a Compensation Event would cause additional cost or would prevent the work being completed before the Intended Completion Date, the Contract Price shall be increased and/or the Intended Completion Date shall be extended. The Project Manager shall decide whether and by how much the Contract Price shall be increased and whether and by how much the Intended Completion Date shall be extended.

42.3 As soon as information demonstrating the effect of each Compensation Event upon the Contractor's forecast cost has been provided by the Contractor, it shall be assessed by the Project Manager, and the Contract Price shall be adjusted accordingly. If the Contractor's forecast is deemed unreasonable, the Project Manager shall adjust the Contract Price based on the Project Manager's own forecast. The Project Manager shall assume that the Contractor shall react competently and promptly to the event.

---

<sup>11</sup>In lump sum contracts, add "or Activity Schedule" after "Program."

<sup>12</sup>In lump sum contracts, replace this paragraph with the following: "The value of work executed shall comprise the value of completed activities in the Activity Schedule."

424 The Contractor shall not be entitled to compensation to the extent that the Procuring Entity's interests are adversely affected by the Contractor's not having given early warning or not having cooperated with the Project Manager.

#### 43. Tax

431 The Project Manager shall adjust the Contract Price if taxes, duties, and other levies are changed between the date 30 days before the submission of bids for the Contract and the date of the last Completion certificate. The adjustment shall be the change in the amount of tax payable by the Contractor, provided such changes are not already reflected in the Contract Price or are a result of GCC Clause 44.

#### 44. Currency of Payment

441 All payments under the contract shall be made in Kenya Shillings

#### 45. Price Adjustment

451 Prices shall be adjusted for fluctuations in the cost of inputs only if **provided for in the SCC**. If so provided, the amounts certified in each payment certificate, before deducting for Advance Payment, shall be adjusted by applying the respective price adjustment factor to the payment amounts due in each currency. A separate formula of the type specified below applies:

$$P = A + B \frac{I_m}{I_o}$$

where:

the Contract Price payable.

P is the adjustment factor for the portion of

A and B are coefficients<sup>13</sup> **specified in the SCC**, representing the non-adjustable and adjustable portions, respectively, of the Contract Price payable and  $I_m$  is the index prevailing at the end of the month being invoiced and  $I_o$  is the index prevailing 30 days before Bid opening for inputs payable.

452 If the value of the index is changed after it has been used in a calculation, the calculation shall be corrected and an adjustment made in the next payment certificate. The index value shall be deemed to take account of all changes in cost due to fluctuations in costs.

#### 46. Retention

461 The Procuring Entity shall retain from each payment due to the Contractor the proportion stated in the **SCC** until Completion of the whole of the Works.

462 Upon the issue of a Certificate of Completion of the Works by the Project Manager, in accordance with GCC 53.1, half the total amount retained shall be repaid to the Contractor and half when the Defects Liability Period has passed and the Project Manager has certified that all Defects notified by the Project Manager to the Contractor before the end of this period have been corrected. The Contractor may substitute retention money with an "on demand" Bank guarantee.

#### 47. Liquidated Damages

471 The Contractor shall pay liquidated damages to the Procuring Entity at the rate per day stated in the **SCC** for each day that the Completion Date is later than the Intended Completion Date. The total amount of liquidated damages shall not exceed the amount defined in the SCC. The Procuring Entity may deduct liquidated damages from payments due to the Contractor. Payment of liquidated damages shall not affect the Contractor's liabilities.

472 If the Intended Completion Date is extended after liquidated damages have been paid, the Project Manager shall correct any overpayment of liquidated damages by the Contractor by adjusting the next payment certificate. The Contractor shall be paid interest on the overpayment, calculated from the date of payment to the date of repayment, at the rates specified in GCC Sub-Clause 41.1.

#### 48. Bonus

481 The Contractor shall be paid a Bonus calculated at the rate per calendar day **stated in the SCC** for each day (less any days for which the Contractor is paid for acceleration) that the Completion is earlier than the Intended Completion Date. The Project Manager shall certify that the Works are complete, although they may not be due to be complete.

#### **49. Advance Payment**

- 49.1 The Procuring Entity shall make advance payment to the Contractor of the amounts stated in the SCC by the date stated in the SCC, against provision by the Contractor of an Unconditional Bank Guarantee in a form and by a bank acceptable to the Procuring Entity in amounts and currencies equal to the advance payment. The Guarantee shall remain effective until the advance payment has been repaid, but the amount of the Guarantee shall be progressively reduced by the amounts repaid by the Contractor. Interest shall not be charged on the advance payment.
- 49.2 The Contractor is to use the advance payment only to pay for Equipment, Plant, Materials, and mobilization expenses required specifically for execution of the Contract. The Contractor shall demonstrate that advance payment has been used in this way by supplying copies of invoices or other documents to the Project Manager.
- 49.3 The advance payment shall be repaid by deducting proportionate amounts from payments otherwise due to the Contractor, following the schedule of completed percentages of the Works on a payment basis. No account shall be taken of the advance payment or its repayment in assessing valuations of work done, Variations, price adjustments, Compensation Events, Bonuses, or Liquidated Damages.

#### **50. Securities**

- 50.1 The Performance Security shall be provided to the Procuring Entity no later than the date specified in the Letter of Acceptance and shall be issued in an amount **specified in the SCC**, by a bank or surety acceptable to the Procuring Entity, and denominated in the types and proportions of the currencies in which the Contract Price is payable. The Performance Security shall be valid until a date 28 day from the date of issue of the Certificate of Completion in the case of a Bank Guarantee, and until one year from the date of issue of the Completion Certificate in the case of a Performance Bond.

#### **51. Dayworks**

- 51.1 If applicable, the Dayworks rates in the Contractor's Bid shall be used only when the Project Manager has given written instructions in advance for additional work to be paid for in that way.
- 51.2 All work to be paid for as Dayworks shall be recorded by the Contractor on forms approved by the Project Manager. Each completed form shall be verified and signed by the Project Manager within two days of the work being done.
- 51.3 The Contractor shall be paid for Dayworks subject to obtaining signed Dayworks forms.

#### **52. Cost of Repairs**

- 52.1 Loss or damage to the Works or Materials to be incorporated in the Works between the Start Date and the end of the Defects Correction periods shall be remedied by the Contractor at the Contractor's cost if the loss or damage arises from the Contractor's acts or omissions.

### **E. Finishing the Contract**

#### **53. Completion**

- 53.1 The Contractor shall request the Project Manager to issue a Certificate of Completion of the Works, and the Project Manager shall do so upon deciding that the whole of the Works is completed.

#### **54. Taking Over**

- 54.1 The Procuring Entity shall take over the Site and the Works within seven days of the Project Manager's issuing a certificate of Completion.

#### **55. Final Account**

- 55.1 The Contractor shall supply the Project Manager with a detailed account of the total amount that the Contractor considers payable under the Contract before the end of the Defects Liability Period. The Project Manager shall issue a Defects Liability Certificate and certify any final payment that is due to the Contractor within 56 days of receiving the Contractor's account if it is correct and complete. If it is not, the Project Manager shall issue within 56 days a schedule that states the scope of the corrections or additions that are necessary. If the Final Account is still unsatisfactory after it has been resubmitted, the Project Manager shall decide on the amount payable to the Contractor and issue a payment certificate.

---

<sup>13</sup>The sum of the two coefficients A and B should be 1 (one) in the formula for each currency. Normally, both coefficients shall be the same in the formulae for all currencies, since coefficient A, for the non-adjustable portion of the payments, is a very approximate figure (usually 0.15) to take account of fixed cost elements or other non-adjustable components. The sum of the adjustments for each currency are added to the Contract Price.

## 56. Operating and Maintenance Manuals

- 56.1 If “as built” Drawings and/or operating and maintenance manuals are required, the Contractor shall supply them by the dates stated in the SCC.
- 56.2 If the Contractor does not supply the Drawings and/or manuals by the dates stated in the SCC pursuant to GCC Sub-Clause 56.1, or they do not receive the Project Manager's approval, the Project Manager shall withhold the amount **stated in the SCC** from payments due to the Contractor.

## 57. Termination

- 57.1 The Procuring Entity or the Contractor may terminate the Contract if the other party causes a fundamental breach of the Contract.
- 57.2 Fundamental breaches of Contract shall include, but shall not be limited to, the following:
- a) the Contractor stops work for 30 days when no stoppage of work is shown on the current Program and the stoppage has not been authorized by the Project Manager;
  - b) the Project Manager instructs the Contractor to delay the progress of the Works, and the instruction is not withdrawn within 30 days;
  - c) the Procuring Entity or the Contractor is made bankrupt or goes into liquidation other than for a reconstruction or amalgamation;
  - d) a payment certified by the Project Manager is not paid by the Procuring Entity to the Contractor within 84 days of the date of the Project Manager's certificate;
  - e) the Project Manager gives Notice that failure to correct a particular Defect is a fundamental breach of Contract and the Contractor fails to correct it within a reasonable period of time determined by the Project Manager;
  - f) the Contractor does not maintain a Security, which is required;
  - g) the Contractor has delayed the completion of the Works by the number of days for which the maximum amount of liquidated damages can be paid, as **defined in the SCC**; or
  - h) if the Contractor, in the judgment of the Procuring Entity has engaged in Fraud and Corruption, as defined in paragraph 2.2 a of the Appendix A to the GCC, in competing for or in executing the Contract, then the Procuring Entity may, after giving fourteen (14) days written notice to the Contractor, terminate the Contract and expel him from the Site.
- 57.3 Notwithstanding the above, the Procuring Entity may terminate the Contract for convenience.
- 57.4 If the Contract is terminated, the Contractor shall stop work immediately, make the Site safe and secure, and leave the Site as soon as reasonably possible.
- 57.5 When either party to the Contract gives notice of a breach of Contract to the Project Manager for a cause other than those listed under GCC Sub-Clause 56.2 above, the Project Manager shall decide whether the breach is fundamental or not.

## 58. Payment upon Termination

- 58.1 If the Contract is terminated because of a fundamental breach of Contract by the Contractor, the Project Manager shall issue a certificate for the value of the work done and Materials ordered less advance payments received up to the date of the issue of the certificate and less the percentage to apply to the value of the work not completed, as specified in the SCC. Additional Liquidated Damages shall not apply. If the total amount due to the Procuring Entity exceeds any payment due to the Contractor, the difference shall be a debt payable to the Procuring Entity.
- 58.2 If the Contract is terminated for the Procuring Entity's convenience or because of a fundamental breach of Contract by the Procuring Entity, the Project Manager shall issue a certificate for the value of the work done, Materials ordered, the reasonable cost of removal of Equipment, repatriation of the Contractor's personnel employed solely on the Works, and the Contractor's costs of protecting and securing the Works, and less advance payments received up to the date of the certificate.

## 59. Property

- 59.1 All Materials on the Site, Plant, Equipment, Temporary Works, and Works shall be deemed to be the property of the Procuring Entity if the Contract is terminated because of the Contractor's default.

## 60. Release from Performance

- 60.1 If the Contract is frustrated by the outbreak of war or by any other event entirely outside the control of either the Procuring Entity or the Contractor, the Project Manager shall certify that the Contract has been frustrated. The Contractor shall make the Site safe and stop work as quickly as possible after receiving this certificate and shall be paid for all work carried out before receiving it and for any work carried out afterwards to which a commitment was made.

## SECTION IX - SPECIAL CONDITIONS OF CONTRACT

Except where otherwise specified, all Special Conditions of Contract should be filled in by the Procuring Entity prior to issuance of the bidding document. Schedules and reports to be provided by the Procuring Entity should be annexed.

Number of GC Clause	Amendments of, and Supplements to, Clauses in the General Conditions of Contract
<b>A. General</b>	
<b>GCC 1.1 (q)</b>	The Procuring Entity is <i>[insert name, address, and name of authorized representative]</i> .
<b>GCC 1.1 (u)</b>	The Intended Completion Date for the whole of the Works shall be Four Months FROM COMMENCEMENT DATE <i>[If different dates are specified for completion of the Works by section (“sectional completion” or milestones), these dates should be listed here]</i>
<b>GCC 1.1 (z)</b>	The Site is located at Chesiumei DCCs Office <b>in Chesiumei Constituency</b>
<b>GCC 1.1 (cc)</b>	The Start Date shall be as agreed with the <b>Project manager (PM)</b>
<b>GCC 1.1 (gg)</b>	The Works consist of AS PER DWGS, BQS,
<b>GCC 2.2</b>	Sectional Completions are: <b>N/A</b> <i>[insert nature and dates, if appropriate]</i>
<b>GCC 5.1</b>	The Project manager <b>MAY DELEGATE</b> any of his duties and responsibilities.
<b>GCC 8.1</b>	Schedule of other contractors: <i>[insert Schedule of Other Contractors, if appropriate]</i>
<b>GCC 9.1</b>	<b>Key Personnel -N/A</b> GCC 9.1 is replaced with the following: 9.1 Key Personnel are the Contractor’s personnel named in this GCC 9.1 of the Special Conditions of Contract. The Contractor shall employ the Key Personnel and use the equipment identified in its Bid, to carry out the Works or other personnel and equipment approved by the Project Manager. The Project Manager shall approve any proposed replacement of Key Personnel and equipment only if their relevant qualifications or characteristics are substantially equal to or better than those proposed in the Bid. <i>[insert the name/s of each Key Personnel agreed by the Procuring Entity prior to Contract signature.]</i>
<b>GCC 13.1</b>	The minimum insurance amounts and deductibles shall be: for loss or damage to the Works, Plant and Materials: 2.5% <i>[insert amounts]</i> . For loss or damage to Equipment: 2.5% <i>[insert amounts]</i> . for loss or damage to property (except the Works, Plant, Materials, and Equipment) in connection with Contract 2.5% <i>[insert amounts]</i> . (d) for personal injury or death: (i) of the Contractor’s employees: 2% <i>[amount]</i> . (ii) of other people: 2% <i>[ amount]</i> .
<b>GCC 14.1</b>	Site Data are: <i>[list Site Data]</i>
<b>GCC 20.1</b>	The Site Possession Date(s) shall be: <b>TO BE COMMUNICATED BY PM</b>
<b>GCC 23.1 &amp;</b>	Appointing Authority for the Adjudicator: <b>ACCOUNTING OFFICER</b>
<b>Number of GC Clause</b>	<b>Amendments of, and Supplements to, Clauses in the General Conditions of Contract</b>
<b>GCC 23.2</b>	

	Hourly rate and types of reimbursable expenses to be paid to the Adjudicator: TO BE DETERMINED <i>[insert hourly fees and reimbursable expenses]</i> .
<b>B. Time Control</b>	
<b>GCC 26.1</b>	<b>The Contractor shall submit for approval a Program for the Works within 7 DAYS from the date of the Letter of Acceptance.</b>
<b>GCC 26.3</b>	The period between Program updates is 7 DAYS. The amount to be withheld for late submission of an updated Program is WHOLE.
<b>C. Quality Control</b>	
<b>GCC 34.1</b> <i>[The Defects</i>	The Defects Liability Period is: SIX MONTHS FROM PRACTICAL COMPLETION DATE. <i>Liability Period is usually limited to 12 months, but could be less in very simple cases]</i>
<b>D. Cost Control</b>	
<b>GCC 38.9</b>	If the value engineering proposal is approved by the Procuring Entity the amount to be paid to the Contractor shall be_% <i>(insert appropriate percentage. The percentage is normally up to 50%)</i> of the reduction in the Contract Price. N/A
<b>GCC 44.1</b>	The currency of the Procuring Entity's Country is: <i>[insert name of currency of the Procuring Entity's Country]</i> . <b>KES</b>
<b>GCC 45.1</b>	The Contract " <i>is not</i> " subject to price adjustment in accordance with GCC Clause 45, and the following information regarding coefficients <i>[specify "does" or "does not"]</i> apply. <i>[Price adjustment is mandatory for contracts which provide for time of completion exceeding 18 months]</i> The coefficients for adjustment of prices are: (a) <i>[insert percentage]</i> percent nonadjustable element (coefficient A). (b) <i>[insert percentage]</i> percent adjustable element (coefficient B). (c) The Index I for shall be <i>[insert index]</i> .
<b>GCC 46.1</b>	The proportion of payments retained is: 10% <i>[insert percentage]</i>
<b>GCC 47.1</b>	The liquidated damages for the whole of the Works are 5% per day. The maximum amount of liquidated damages for the whole of the Works is 10% of the final Contract Price.
<b>GCC 48.1</b>	The Bonus for the whole of the Works is <i>[insert percentage of final Contract Price]</i> per day. The maximum amount of Bonus for the whole of the Works is <i>[insert percentage]</i> of the final Contract Price. N/A
<b>Number of GC Clause</b>	<b>Amendments of, and Supplements to, Clauses in the General Conditions of Contract</b>
<b>GCC 49.1</b>	The Advance Payments shall be: <i>[insert amount(s)]</i> and shall be paid to the Contractor not later than <i>[insert date(s)]</i> . SHALL NOT BE APPLICABLE

<b>GCC 50.1</b>	<p>The Performance Security amount is 5% OF CONTRACT SUM <i>[insert amount(s) denominated in the types and proportions of the currencies in which the Contract Price is payable, or in a freely convertible currency acceptable to the Procuring Entity]</i></p> <p>(a) Performance Security – Bank Guarantee: in the amount(s) of <i>[insert related figure(s)]</i> percent of the Accepted Contract Amount and in the same currency(ies) of the Accepted Contract Amount.-NA</p> <p>(b) Performance Security – N/A Performance Bond: in the amount(s) of <i>[insert related figure(s)]</i> percent of the Accepted Contract Amount and in the same currency(ies) of the Accepted Contract Amount.</p>
<b>E. Finishing the Contract</b>	
<b>GCC 56.1</b>	<p>The date by which operating and maintenance manuals are required is <i>[insert date]</i>. The date by which “as built” drawings are required is N/A<i>[insert date]</i>.</p>
<b>GCC 56.2</b>	<p>The amount to be withheld for failing to produce “as built” drawings and/or operating and maintenance manuals by the date required in GCC 58.1 is 0.05% <i>[insert amount in local currency]</i>.</p>
<b>GCC 57.2 (g)</b>	<p>The maximum number of days is: <i>[insert number; consistent with Clause 47.1 on liquidated damages]</i>.</p>
<b>GCC 58.1</b>	<p>The percentage to apply to the value of the work not completed, representing the Procuring Entity’s additional cost for completing the Works, is 20%.</p>

## **FORM No 1: NOTIFICATION OF INTENTION TO AWARD**

This Notification of Intention to Award shall be sent to each Tenderer that submitted a Tender. Send this Notification to the Tenderer's Authorized Representative named in the Tender Information Form on the format below.

-----

### **FORMAT**

1. For the attention of Tenderer's Authorized Representative

- i) Name: *[insert Authorized Representative's name]*
- ii) Address: *[insert Authorized Representative's Address]*
- iii) Telephone: *[insert Authorized Representative's telephone/fax numbers]*
- iv) Email Address: *[insert Authorized Representative's email address]*

*[IMPORTANT: insert the date that this Notification is transmitted to Tenderers. The Notification must be sent to all Tenderers simultaneously. This means on the same date and as close to the same time as possible.]*

2. Date of transmission: *[email]* on *[date]* (local time)

This Notification is sent by *(Name and designation)* \_\_\_\_\_

3. Notification of Intention to Award

- i) Procuring Entity: *[insert the name of the Procuring Entity]*
- ii) Project: *[insert name of project]*
- iii) Contract title: *[insert the name of the contract]*
- iv) Country: *[insert country where ITT is issued]*
- v) ITT No: *[insert ITT reference number from Procurement Plan]*

This Notification of Intention to Award (Notification) notifies you of our decision to award the above contract. The transmission of this Notification begins the Standstill Period. During the Standstill Period, you may:

4. Request a debriefing in relation to the evaluation of your tender

Submit a Procurement-related Complaint in relation to the decision to award the contract.

a) The successful tenderer

- i) Name of successful Tender \_\_\_\_\_
- ii) Address of the successful Tender \_\_\_\_\_
- iii) Contract price of the successful Tender Kenya Shillings \_\_\_\_\_ (in words \_\_\_\_\_)

b) Other Tenderers

Names of all Tenderers that submitted a Tender. If the Tender's price was evaluated include the evaluated price as well as the Tender price as read out. For Tenders not evaluated, give one main reason the Tender was unsuccessful.

SNo	Name of Tender	Tender Price as read out	Tender's evaluated price (Note a)	One Reason Why not Evaluated
1				
2				
3				
4				
5				

(Note a) State NE if not evaluated

5. How to request a debriefing

- a) DEADLINE: The deadline to request a debriefing expires at midnight on *[insert date]* (local time).
- b) You may request a debriefing in relation to the results of the evaluation of your Tender. If you decide to request a debriefing your written request must be made within three (5) Business Days of receipt of this Notification of Intention to Award.
- c) Provide the contract name, reference number, name of the Tenderer, contact details; and address the request for debriefing as follows:
  - i) Attention: *[insert full name of person, if applicable]*
  - ii) Title/position: *[insert title/position]*
  - ii) Agency: *[insert name of Procuring Entity]*
  - iii) Email address: *[insert email address]*
- d) If your request for a debriefing is received within the 3 Days deadline, we will provide the debriefing within five (3) Business Days of receipt of your request. If we are unable to provide the debriefing within this

period, the Standstill Period shall be extended by five (3) Days after the date that the debriefing is provided. If this happens, we will notify you and confirm the date that the extended Standstill Period will end.

- e) The debriefing may be in writing, by phone, video conference call or in person. We shall promptly advise you in writing how the debriefing will take place and confirm the date and time.
- f) If the deadline to request a debriefing has expired, you may still request a debriefing. In this case, we will provide the debriefing as soon as practicable, and normally no later than fifteen (15) Days from the date of publication of the Contract Award Notice.

**6. How to make a complaint**

- a) Period: Procurement-related Complaint challenging the decision to award shall be submitted by midnight, [insert date] (local time).
- b) Provide the contract name, reference number, name of the Tenderer, contact details; and address the Procurement-related Complaint as follows:
  - i) Attention: [insert full name of person, if applicable]
  - ii) Title/position: [insert title/position]
  - iii) Agency: [insert name of Procuring Entity]
  - iv) Email address: [insert email address]
- c) At this point in the procurement process, you may submit a Procurement-related Complaint challenging the decision to award the contract. You do not need to have requested, or received, a debriefing before making this complaint. Your complaint must be submitted within the Standstill Period and received by us before the Standstill Period ends.
- d) Further information: For more information refer to the Public Procurement and Disposals Act 2015 and its Regulations available from the Website [info@ppra.go.ke](mailto:info@ppra.go.ke) or [complaints@ppra.go.ke](mailto:complaints@ppra.go.ke).  
You should read these documents before preparing and submitting your complaint.
- e) There are four essential requirements:
  - i) You must be an 'interested party'. In this case, that means a Tenderer who submitted a Tender in this tendering process, and is the recipient of a Notification of Intention to Award.
  - ii) The complaint can only challenge the decision to award the contract.
  - iii) You must submit the complaint within the period stated above.
  - iv) You must include, in your complaint, all of the information required to support your complaint.

**7. Standstill Period**

- i) DEADLINE: The Standstill Period is due to end at midnight on [insert date] (local time).
- ii) The Standstill Period lasts ten (14) Days after the date of transmission of this Notification of Intention to Award.
- iii) The Standstill Period may be extended as stated in paragraph Section 5 (d) above.

If you have any questions regarding this Notification please do not hesitate to contact us. On behalf of the Procuring Entity:

**Signature:** \_\_\_\_\_ **Name:** \_\_\_\_\_

**Title/position:** \_\_\_\_\_ **Telephone:** \_\_\_\_\_ **Email:** \_\_\_\_\_

**FORM NO. 2 - REQUEST FOR REVIEW**

**FORM FOR REVIEW(r.203(1))**

**PUBLIC PROCUREMENT ADMINISTRATIVE REVIEW BOARD**

**APPLICATION NO.....OF.....20.....**

**BETWEEN**

.....**APPLICANT**

**AND**

.....**RESPONDENT (Procuring Entity)**

Request for review of the decision of the..... (Name of the Procuring Entity of .....dated the...day of .....20.....in the matter of Tender No.....of .....20..... for.....(Tender description).

**REQUEST FOR REVIEW**

I/We.....,the above named Applicant(s), of address: Physical address.....P. O. Box No..... Tel. No.....Email....., hereby request the Public Procurement Administrative Review Board to review the whole/part of the above mentioned decision on the following grounds , namely:

- 1.
- 2.

By this memorandum, the Applicant requests the Board for an order/orders that:

- 1.
- 2.

SIGNED .....(Applicant) Dated on.....day of ...../...20.....

---

FOR OFFICIAL USE ONLY Lodged with the Secretary Public Procurement Administrative Review Board on..... day of .....20.....

**SIGNED**

**Board Secretary**

**FORM NO 3: LETTER OF AWARD**

*[letterhead paper of the Procuring Entity] [date]*

To: *[name and address of the Contractor]*

This is to notify you that your Tender dated *[date]* for execution of the *[name of the Contract and identification number, as given in the Contract Data]* for the Accepted Contract Amount *[amount in numbers and words] [name of currency]*, as corrected and modified in accordance with the Instructions to Tenderers, is hereby accepted by.....(*name of Procuring Entity*).

You are requested to furnish the Performance Security within 30 days in accordance with the Conditions of Contract, using, for that purpose, one of the Performance Security Forms included in Section VIII, Contract Forms, of the Tender Document.

Authorized Signature:.....

Name and Title of Signatory:.....

Name of Procuring Entity.....

Attachment: *Contract Agreement*.....

## FORM NO 4: CONTRACT AGREEMENT

THIS AGREEMENT made the \_\_\_\_\_ day of \_\_\_\_\_, 20\_\_\_\_, between \_\_\_\_\_ of \_\_\_\_\_ (hereinafter “the Procuring Entity”), of the one part, and \_\_\_\_\_ of \_\_\_\_\_ (hereinafter “the Contractor”), of the other part:

WHEREAS the Procuring Entity desires that the Works known as \_\_\_\_\_ should be executed by the Contractor, and has accepted a Tender by the Contractor for the execution and completion of these Works and the remedying of any defects therein,

The Procuring Entity and the Contractor agree as follows:

1. In this Agreement words and expressions shall have the same meanings as are respectively assigned to them in the Contract documents referred to.
2. The following documents shall be deemed to form and be read and construed as part of this Agreement. This Agreement shall prevail over all other Contract documents.
  - a) the Letter of Acceptance
  - b) the Letter of Tender
  - c) the addenda Nos \_\_\_\_\_ (if any)
  - d) the Special Conditions of Contract
  - e) the General Conditions of Contract;
  - f) the Specifications
  - g) the Drawings; and
  - h) the completed Schedules and any other documents forming part of the contract.
3. In consideration of the payments to be made by the Procuring Entity to the Contractor as specified in this Agreement, the Contractor hereby covenants with the Procuring Entity to execute the Works and to remedy defects therein in conformity in all respects with the provisions of the Contract.
4. The Procuring Entity hereby covenants to pay the Contractor in consideration of the execution and completion of the Works and the remedying of defects therein, the Contract Price or such other sum as may become payable under the provisions of the Contract at the times and in the manner prescribed by the Contract.

IN WITNESS whereof the parties hereto have caused this Agreement to be executed in accordance with the Laws of Kenya on the day, month and year specified above.

Signed and sealed by \_\_\_\_\_ (for the Procuring Entity)

Signed and sealed by \_\_\_\_\_ (for the Contractor).

**FORM NO. 5 - PERFORMANCE SECURITY**

**[Option 1 - Unconditional Demand Bank Guarantee]**

*[Guarantor letterhead]*

**Beneficiary:** \_\_\_\_\_ *[insert name and Address of Procuring Entity]* **Date:** \_\_\_\_\_

\_\_\_\_\_ *[Insert date of issue]*

**Guarantor:** *[Insert name and address of place of issue, unless indicated in the letterhead]*

1. We have been informed that \_\_\_\_\_ (hereinafter called "the Contractor") has entered into Contract No. \_\_\_\_\_ dated \_\_\_\_\_ with (name of Procuring Entity) \_\_\_\_\_ (the Procuring Entity as the Beneficiary), for the execution of \_\_\_\_\_ (hereinafter called "the Contract").
2. Furthermore, we understand that, according to the conditions of the Contract, a performance guarantee is required.
3. At the request of the Contractor, we as Guarantor, hereby irrevocably undertake to pay the Beneficiary any sum or sums not exceeding in total an amount of \_\_\_\_\_ (in words),<sup>1</sup> such sum being payable in the types and proportions of currencies in which the Contract Price is payable, upon receipt by us of the Beneficiary's complying demand supported by the Beneficiary's statement, whether in the demand itself or in a separate signed document accompanying or identifying the demand, stating that the Applicant is in breach of its obligation(s) under the Contract, without the Beneficiary needing to prove or to show grounds for your demand or the sum specified therein.
4. This guarantee shall expire, no later than the .... Day of ....., 2.....<sup>2</sup>, and any demand for payment under it must be received by us at the office indicated above on or before that date.
5. The Guarantor agrees to a one-time extension of this guarantee for a period notto exceed *[six months]* *[oneyear]*, in response to the Beneficiary's written request for such extension, such request to be presented to the Guarantor before the expiry of the guarantee.”

*[Name of Authorized Official, signature(s) and seals/stamps].*

**Note:** *All italicized text (including footnotes) is for use in preparing this form and shall be deleted from the final product.*

<sup>1</sup>The Guarantor shall insert an amount representing the percentage of the Accepted Contract Amount specified in the Letter of Acceptance, less provisional sums, if any, and denominated either in the currency of the Contract or a freely convertible currency acceptable to the Beneficiary.

<sup>2</sup>Insert the date twenty-eight days after the expected completion date as described in GC Clause 11.9. The Procuring Entity should note that in the event of an extension of this date for completion of the Contract, the Procuring Entity would need to request an extension of this guarantee from the Guarantor. Such request must be in writing and must be made prior to the expiration date established in the guarantee.

**FORM No. 6 - PERFORMANCE SECURITY**

**[Option 2– Performance Bond]**

*[Note: Procuring Entities are advised to use Performance Security – Unconditional Demand Bank Guarantee instead of Performance Bond due to difficulties involved in calling Bondholder to action]*

*[Guarantor letterhead or SWIFT identifier code]*

**Beneficiary:** \_\_\_\_\_ *[insert name and Address of Procuring Entity]* **Date:** \_\_\_\_\_  
\_\_\_\_\_ *[Insert date of issue]*.

**PERFORMANCE BOND No.:** \_\_\_\_\_

**Guarantor:** *[Insert name and address of place of issue, unless indicated in the letterhead]*

1. By this Bond \_\_\_\_\_ as Principal (hereinafter called “the Contractor”) and \_\_\_\_\_] as Surety (hereinafter called “the Surety”), are held and firmly bound unto \_\_\_\_\_] as Obligee (hereinafter called “the Procuring Entity”) in the amount of \_\_\_\_\_ for the payment of which sum well and truly to be made in the types and proportions of currencies in which the Contract Price is payable, the Contractor and the Surety bind themselves, their heirs, executors, administrators, successors and assigns, jointly and severally, firmly by these presents.
2. WHEREAS the Contractor has entered into a written Agreement with the Procuring Entity dated the \_\_\_\_\_ day of \_\_\_\_\_, 20, for \_\_\_\_\_ in accordance with the documents, plans, specifications, and amendments thereto, which to the extent herein provided for, are by reference made part hereof and are hereinafter referred to as the Contract.
3. NOW, THEREFORE, the Condition of this Obligation is such that, if the Contractor shall promptly and faithfully perform the said Contract (including any amendments thereto), then this obligation shall be null and void; otherwise, it shall remain in full force and effect. Whenever the Contractor shall be, and declared by the Procuring Entity to be, in default under the Contract, the Procuring Entity having performed the Procuring Entity's obligations thereunder, the Surety may promptly remedy the default, or shall promptly:
  - 1) complete the Contract in accordance with its terms and conditions; or
  - 2) obtain a tender or tenders from qualified tenderers for submission to the Procuring Entity for completing the Contract in accordance with its terms and conditions, and upon determination by the Procuring Entity and the Surety of the lowest responsive Tenderers, arrange for a Contract between such Tenderer, and Procuring Entity and make available as work progresses (even though there should be a default or a succession of defaults under the Contract or Contracts of completion arranged under this paragraph) sufficient funds to pay the cost of completion less the Balance of the Contract Price; but not exceeding, including other costs and damages for which the Surety may be liable hereunder, the amount set forth in the first paragraph hereof. The term “Balance of the Contract Price,” as used in this paragraph, shall mean the total amount payable by Procuring Entity to Contractor under the Contract, less the amount properly paid by Procuring Entity to Contractor; or
  - 3) pay the Procuring Entity the amount required by Procuring Entity to complete the Contract in accordance with its terms and conditions up to a total not exceeding the amount of this Bond.
4. The Surety shall not be liable for a greater sum than the specified penalty of this Bond.
5. Any suit under this Bond must be instituted before the expiration of one year from the date of the issuing of the Taking-Over Certificate. No right of action shall accrue on this Bond to or for the use of any person or corporation other than the Procuring Entity named herein or the heirs, executors, administrators, successors, and assigns of the Procuring Entity.
6. In testimony whereof, the Contractor has hereunto set his hand and affixed his seal, and the Surety has caused these presents to be sealed with his corporate seal duly attested by the signature of his legal representative, this day \_\_\_\_\_ of \_\_\_\_\_ 20\_\_\_\_\_.

SIGNED ON \_\_\_\_\_ on behalf of By \_\_\_ in the capacity of In the  
presence of

SIGNED ON \_\_\_\_\_ on behalf of By \_\_\_ in the capacity of In the  
presence of

**FORM NO. 7 - ADVANCE PAYMENT SECURITY**

**[Demand Bank Guarantee]**

*[Guarantor letterhead]*

**Beneficiary:** \_\_\_\_\_ *[Insert name and Address of Procuring Entity]*

**Date:** \_\_\_\_\_ *[Insert date of issue]*

**ADVANCE PAYMENT GUARANTEE No.:** \_\_\_\_\_ *[Insert guarantee reference number]* **Guarantor:** \_\_\_\_\_  
\_\_\_\_\_ *[Insert name and address of place of issue, unless indicated in the letterhead]*

1. We have been informed that \_\_\_\_\_ (hereinafter called "the Contractor") has entered into Contract No. \_\_\_\_\_ dated \_\_\_\_\_ with the Beneficiary, for the execution of \_\_\_\_\_ (hereinafter called "the Contract").
2. Furthermore, we understand that, according to the conditions of the Contract, an advance payment in the sum \_\_\_\_\_ (in words) is to be made against an advance payment guarantee.
3. At the request of the Contractor, we as Guarantor, hereby irrevocably undertake to pay the Beneficiary any sum or sums not exceeding in total an amount of \_\_\_\_\_ (in words \_\_\_\_\_)<sup>1</sup> upon receipt by us of the Beneficiary's complying demand supported by the Beneficiary's statement, whether in the demand itself or in a separate signed document accompanying or identifying the demand, stating either that the Applicant:
  - a) has used the advance payment for purposes other than the costs of mobilization in respect of the Works; or
  - b) has failed to repay the advance payment in accordance with the Contract conditions, specifying the amount which the Applicant has failed to repay.
4. A demand under this guarantee may be presented as from the presentation to the Guarantor of a certificate from the Beneficiary's bank stating that the advance payment referred to above has been credited to the Contractor on its account number \_\_\_\_\_ at \_\_\_\_\_.
5. The maximum amount of this guarantee shall be progressively reduced by the amount of the advance payment repaid by the Contractor as specified in copies of interim statements or payment certificates which shall be presented to us. This guarantee shall expire, at the latest, upon our receipt of a copy of the interim payment certificate indicating that ninety (90) percent of the Accepted Contract Amount, less provisional sums, has been certified for payment, or on the \_\_\_ day of \_\_\_\_\_, 2<sup>2</sup>, whichever is earlier. Consequently, no demand for payment under this guarantee must be received by us at this office on or before that date.
6. The Guarantor agrees to a one-time extension of this guarantee for a period not to exceed *[six months]* *[one year]*, in response to the Beneficiary's written request for extension, such request to be presented to the Guarantor before the expiry of the guarantee.

*[Name of Authorized Official, signature(s) and seals/stamps]*

***Note: All italicized text (including footnotes) is for use in preparing this form and shall be deleted from the final product.***

<sup>1</sup>The Guarantor shall insert an amount representing the amount of the advance payment and denominated either in the currency of the advance payment as specified in the Contract.

<sup>2</sup>Insert the expected expiration date of the Time for Completion. The Procuring Entity should note that in the event of an extension of the time for completion of the Contract, the Procuring Entity would need to request an extension of this guarantee from the Guarantor. Such request must be in writing and must be made prior to the expiration date established in the guarantee.

**FORM NO. 8 - RETENTION MONEY SECURITY**

**[Demand Bank Guarantee]**

*[Guarantor letterhead]*

**Beneficiary:** \_\_\_\_\_ *[Insert name and Address of Procuring Entity]*

**Date:** \_\_\_\_\_ *[Insert date of issue]*

**Advance payment guarantee no.** *[Insert guarantee reference number]*

**Guarantor:** *[Insert name and address of place of issue, unless indicated in the letterhead]*

1. We have been informed that \_\_\_\_\_ *[insert name of Contractor, which in the case of a joint venture shall be the name of the joint venture]* (hereinafter called "the Contractor") has entered into Contract No. \_\_\_\_\_ *[insert reference number of the contract]* dated \_\_\_\_\_ with the Beneficiary, for the execution of \_\_\_\_\_ *[insert name of contract and brief description of Works]* (hereinafter called "the Contract").
2. Furthermore, we understand that, according to the conditions of the Contract, the Beneficiary retains moneys up to the limit set forth in the Contract ("the Retention Money"), and that when the Taking-Over Certificate has been issued under the Contract and the first half of the Retention Money has been certified for payment, and payment of *[insert the second half of the Retention Money]* is to be made against a Retention Money guarantee.
3. At the request of the Contractor, we, as Guarantor, hereby irrevocably undertake to pay the Beneficiary any sum or sums not exceeding in total an amount of *[insert amount in figures]* \_\_\_\_\_ *([insert amount in words \_\_\_\_\_])*<sup>1</sup> upon receipt by us of the Beneficiary's complying demand supported by the Beneficiary's statement, whether in the demand itself or in a separate signed document accompanying or identifying the demand, stating that the Contractor is in breach of its obligation(s) under the Contract, without your needing to prove or show grounds for your demand or the sum specified therein.
4. A demand under this guarantee may be presented as from the presentation to the Guarantor of a certificate from the Beneficiary's bank stating that the second half of the Retention Money as referred to above has been credited to the Contractor on its account number \_\_\_\_\_ at \_\_\_\_\_ *[insert name and address of Applicant's bank]*.
5. This guarantee shall expire no later than the ..... Day of ....., 2.....<sup>2</sup>, and any demand for payment under it must be received by us at the office indicated above on or before that date.
6. The Guarantor agrees to a one-time extension of this guarantee for a period not to exceed *[six months]* *[one year]*, in response to the Beneficiary's written request for such extension, such request to be presented to the Guarantor before the expiry of the guarantee.

*[Name of Authorized Official, signature(s) and seals/stamps]*

***Note: All italicized text (including footnotes) is for use in preparing this form and shall be deleted from the final product.***

<sup>1</sup>The Guarantor shall insert an amount representing the amount of the second half of the Retention Money.

<sup>2</sup>Insert a date that is twenty-eight days after the expiry of retention period after the actual completion date of the contract. The Procuring Entity should note that in the event of an extension of this date for completion of the Contract, the Procuring Entity would need to request an extension of this guarantee from the Guarantor. Such request must be in writing and must be made prior to the expiration date established in the guarantee.

**FORM NO. 9 BENEFICIAL OWNERSHIP DISCLOSURE FORM**

**(Amended and issued pursuant to PPRA CIRCULAR No. 02/2022)**

**INSTRUCTIONS TO TENDERERS: DELETE THIS BOX ONCE YOU HAVE COMPLETED THE FORM**

*This Beneficial Ownership Disclosure Form (“Form”) is to be completed by the successful tenderer pursuant to Regulation 13 (2A) and 13 (6) of the Companies (Beneficial Ownership Information) Regulations, 2020. In case of joint venture, the tenderer must submit a separate Form for each member. The beneficial ownership information to be submitted in this Form shall be current as of the date of its submission.*

*For the purposes of this Form, a Beneficial Owner of a Tenderer is any natural person who ultimately owns or controls the legal person (tenderer) or arrangements or a natural person on whose behalf a transaction is conducted, and includes those persons who exercise ultimate effective control over a legal person (Tenderer) or arrangement.*

Tender Reference No.: \_\_\_\_\_ [insert identification no]

Name of the Tender Title/Description: \_\_\_\_\_ [insert name of the assignment] to:  
 \_\_\_\_\_ [insert complete name of Procuring Entity]

In response to the requirement in your notification of award dated \_\_\_\_\_ [insert date of notification of award] to furnish additional information on beneficial ownership: \_\_\_\_\_ [select one option as applicable and delete the options that are not applicable]

I) We here by provide the following beneficial ownership information.

**Details of beneficial ownership**

	Details of all Beneficial Owners		% of shares a person holds in the company Directly or indirectly	% of voting rights a person holds in the company	Whether a person directly or indirectly holds a right to appoint or remove a member of the board of directors of the company or an equivalent governing body of the Tenderer (Yes / No)	Whether a person directly or indirectly exercises significant influence or control over the Company (tenderer) (Yes / No)
1.	Full Name		Directly----- ----- % of shares	Directly..... .....% of voting rights	1. Having the right to appoint a majority of the board of the directors or an equivalent governing body of the Tenderer: Yes ----No---- 2. Is this right held directly or indirectly?:  Direct..... ...  Indirect..... .....	1. Exercises significant influence or control over the Company body of the Company (tenderer)  Yes ----No----  2. Is this influence or control exercised directly or indirectly?  Direct.....  Indirect.....
	National identity card number or Passport number					
	Personal Identification Number (where applicable)		Indirectly--- -----% of shares	Indirectly----- % of voting rights		
	Nationality					
	Date of birth [dd/mm/yyyy]					
	Postal address					
	Residential address					
	Telephone number					
	Email address					
Occupation or profession						
2.	Full Name		Directly-----	Directly.....		

Details of all Beneficial Owners		% of shares a person holds in the company Directly or indirectly	% of voting rights a person holds in the company	Whether a person directly or indirectly holds a right to appoint or remove a member of the board of directors of the company or an equivalent governing body of the Tenderer (Yes / No)	Whether a person directly or indirectly exercises significant influence or control over the Company (tenderer) (Yes / No)
National identity card number or Passport number		---- % of shares	.....% of voting rights	1. Having the right to appoint a majority of the board of the directors or an equivalent governing body of the Tenderer: Yes ----No---- 2. Is this right held directly or indirectly?:  Direct..... ...  Indirect..... .....	1. Exercises significant influence or control over the Company body of the Company (tenderer) Yes ----No----  2. Is this influence or control exercised directly or indirectly?  Direct.....  Indirect.....
Personal Identification Number (where applicable)		Indirectly---- % of shares	Indirectly----- % of voting rights		
Nationality(ies)					
Date of birth [dd/mm/yyyy]					
Postal address					
Residential address					
Telephone number					
Email address					
Occupation or profession					
<b>3.</b>					
<b>e.t</b>					
<b>.c</b>					

II) Am fully aware that beneficial ownership information above shall be reported to the Public Procurement Regulatory Authority together with other details in relation to contract awards and shall be maintained in the Government Portal, published and made publicly available pursuant to Regulation 13(5) of the Companies (Beneficial Ownership Information) Regulations, 2020. (Notwithstanding this paragraph Personally Identifiable Information in line with the Data Protection Act shall not be published or made public). *Note that Personally Identifiable Information (PII) is defined as any information that can be used to distinguish one person from another and can be used to deanonymize previously anonymous data. This information includes National identity card number or Passport number, Personal Identification Number, Date of birth, Residential address, email address and Telephone number.*

III) In determining who meets the threshold of who a beneficial owner is, the Tenderer must consider a natural person who in relation to the company:

- (a) holds at least ten percent of the issued shares in the company either directly or indirectly;
- (b) exercises at least ten percent of the voting rights in the company either directly or indirectly;
- (c) holds a right, directly or indirectly, to appoint or remove a director of the company; or
- (d) exercises significant influence or control, directly or indirectly, over the company.

IV) What is stated to herein above is true to the best of my knowledge, information and belief.

Name of the Tenderer.....\*[insert complete name of the Tenderer]\_\_\_\_\_

Name of the person duly authorized to sign the Tender on behalf of the Tenderer: \*\* [insert complete name of person duly authorized to sign the Tender]

Designation of the person signing the Tender..... [insert complete title of the person signing the Tender]

Signature of the person named above.....[insert signature of person whose name and capacity are shown above]

Date this ..... [insert date of signing] day of.....[Insert month], [insert year]

Bidder Official Stamp

# **BILL OF QUANTITIES**



## REPUBLIC OF KENYA

### NATIONAL GOVERNMENT CONSTITUENCIES DEVELOPMENT FUND BOARD (NG-CDF) CHESUMEI CONSTITUENCY

#### PROPOSED DIGITAL HUB AT DEPUTY COUNTY COMMISSIONER OFFICE-CHESUMEI SUB-COUNTY

#### BILLS OF QUANTITIES

**Procuring Entity:** **NG-CDF CHESUMEI CONSTITUENCY**  
P.O. BOX 40 - 30300  
**KAPSABET**  
Telephone:  
Website:  
E-mail:

**Prepared By:** **Public Works Office**  
State Department for Public Works  
P.O. Box

**JUNE 2026**

<i>Item</i>	<i>Description</i>	<i>Amount KSh</i>
	<p><b><u>BILL NO. 1</u></b></p> <p><b><u>PARTICULAR PRELIMINARIES</u></b></p> <p><b>1.1 PRICING ITEMS OF PRELIMINARIES</b></p> <p>Prices <b>SHALL BE INSERTED</b> against items of “preliminaries” in the tenderer’s priced Bills of Quantities. The contractor is advised to read and understand all preliminary items</p> <p><b>1.2 DESCRIPTION OF THE WORKS</b></p> <p>The works to be carried out comprises PROPOSED ADIGITAL HUB AT DEPUTY COUNTY COMMISSIONER-CHESUMEI SUB COUNTY</p> <p><b>1.3 MEASUREMENTS</b></p> <p>In the event of any discrepancies arising between the Bills of Quantities and the actual works, the site measurements shall generally take precedence. However, such discrepancies between any contract documents shall immediately be referred to the PROJECT MANAGER in accordance with Clause 3 of the Conditions of Contract. The discrepancies shall then be treated as a variation and be dealt with in accordance with Clause 3 of the said Conditions.</p> <p><b>1.4 LOCATION OF SITE</b></p> <p>The site of the proposed works is at DEPUTY COUNTY COMMISSIONER OFFICE - CHESUMEI. The Contractor is advised to visit the site, to familiarize with the nature and position of the site. No claims arising from the Contractor’s failure to do so will be entertained.</p> <p><b>1.5 SIGNING OF THE TENDER DOCUMENTS</b></p> <p>The bidder shall append his / her signature and / or company ,,s rubberstamp on each and every page of tender document.</p> <p><b>1.6 DEMOLITIONS AND ALTERATIONS</b></p> <p>The Contractor is to allow for all temporary protection required during the works including ordinary and special dust screens, hoardings, barriers, warning signs, etc as directed by the Project Manager and as necessary for the adequate propping and protection of existing property, finishes, workmen employed on the site, employer's agents and the public. Any damage or loss incurred due to the insufficiency of such protection must be made good by the Contractor. All protective devices are to be removed on completion of the works and any necessary making good consequent upon this is to be executed to the satisfaction of the Project Manager</p>	
	<b>Carried to collection</b>	

<b>Item</b>	<b>Description</b>	<b>Amount KSh</b>
	<p>The works shall be propped, strutted and supported as necessary before any alteration or demolition work commences. Prices shall include for all cleaning and preparatory work to structure and finishes and for making good to all finishes on completion whether or not specifically described.</p> <p>Unless described as set aside for re-use all arising debris and surplus materials shall be carefully removed from building and carted away from site.</p> <p>The Contractor shall be entirely responsible for any breakage or damage which may occur to materials required for re-use during their removal unless it is certified by the Project Manager that such damage or breakage was inevitable as a result of the condition of the item concerned</p>	
1.7	<b>CLEARING AWAY</b>	
	<p>The Contractor shall remove all temporary works, rubbish, debris and surplus materials from the site as they accumulate and upon completion of the works, remove and clear away all plant, equipment, rubbish, unused materials and stains and leave in a clean and tidy state to the reasonable satisfaction of the Project Manager.</p> <p>The whole of the works shall be delivered up clean, complete and in perfect condition in every respect to the satisfaction of the Project Manager.</p>	
1.8	<b>CLAIMS</b>	
	<p>It shall be a condition of this contract that upon it becoming reasonably apparent to the Contractor that he has incurred losses and / or expenses due to any of the contract conditions, or by any other reason whatsoever, he shall present such a claim or intent to claim notice to the PROJECT MANAGER within the contract period. No claim shall be entertained upon the expiry of the said contract period.</p>	
1.9	<b>PAYMENTS</b>	
	<p>The tenderer's attention is drawn to the fact that the GOVERNMENT DOES NOT MAKE ADVANCE PAYMENTS but pays for work done and materials delivered to site: all in accordance with Clause 14 of the Conditions of Contract Agreement. In order to facilitate this, a list of the general component elements for the works is given at the summary page of these specifications and the tenderer is requested to break down his tender sum commensurate to the said elements</p>	
1.10	<b>PREVENTION OF ACCIDENT, DAMAGE OR LOSS</b>	
	<p>The Contractor is notified that these works are to be carried out on a restricted site where the client is going on with other normal activities. The Contractor is thus instructed to take reasonable care in the execution of the works as to prevent accidents, damage or loss and disruption of activities being carried out by the Client. The Contractor shall allow in his rates any expense he deemed necessary by taking such care within the site.</p>	
	<b>Carried to collection</b>	

<b>Item</b>	<b>Description</b>	<b>Amount KSh</b>
1.11	<p><b>WORKING CONDITIONS</b></p> <p>The Contractor shall allow in his rates for any interference that he may encounter in the course of the works for the Client may in some cases ask the Contractor not to proceed with the works until some activities within the site are completed, as the facility will be operating as usual during the course of the contract.</p>	
1.12	<p><b>SIGNBOARD</b></p> <p>Allow for providing, erecting, maintaining throughout the course of the Contract and afterwards clearing away a signboard as designed, specified and approved by the Project Manager.</p>	
1.13	<p><b>LABOUR CAMPS</b></p> <p>The Contractor shall not be allowed to house labour on site. Allow for transporting workers to and from the site during the tenure of the contract.</p>	
1.14	<p><b>MATERIALS FROM DEMOLITIONS</b></p> <p>Any materials arising from demolitions and not re-used shall become the property of the Client</p>	
1.15	<p><b>PRICING RATES</b></p> <p>The tenderer shall include for all costs in executing the whole of the works, including transport, replacing damaged items, fixing, all to comply with the said Conditions of Contract.</p>	
1.16	<p><b>URGENCY OF THE WORKS</b></p> <p>The Contractor is notified that these “ works are urgent” and should be completed within the period stated in these Particular Preliminaries.</p> <p>The Contractor shall allow in his rates for any costs he/ she deems that he/she may incur by having to complete these works within the stipulated contract period.</p>	
1.17	<p><b>PAYMENT FOR MATERIALS ON SITE</b></p> <p>All materials for incorporation in the works must be stored on site before payment is effected, unless specifically exempted by the Project Manager. This is to include materials of the Contractor, nominated sub-Contractors and nominated suppliers.</p>	
1.18	<p><b>EXISTING SERVICES</b></p> <p>Prior to the commencement of any work, the Contractor is to ascertain from the relevant authority the exact position, depth and level of all existing services in the area and he/she shall make whatever provisions may be required by the authorities concerned for the support, maintenance and protection of such services.</p>	
	<b>Carried to collection</b>	

<b>Item</b>	<b>Description</b>	<b>Amount KSh</b>
1.19	<p><b>CONTRACT COMPLETION PERIOD</b></p> <p>The „PROJECT MANAGER“ shall strictly monitor the Contractors progress in relation to the progress chart and should it be found necessary the „PROJECT MANAGER“ shall inform the Contractor in writing that his actual performance on site is not satisfactory .In all such cases the Contractor shall accelerate his rate of performance production and progress by all means such as additional labour,plant, e.t.c and working overtime all at his cost.</p>	
1.20	<p><b>BID SECURITY</b></p> <p>The tenderer shall provide a Bid Security not exceeding 2% in accordance with clause 19 of the Instructions to Tenderers.</p>	
1.21	<p><b>TENDER DOCUMENTS</b></p> <p>Tender documents are as listed in Clause 6.1 of the Instruction to Tenderers</p>	
1.22	<p><b>DELIVERY OF TENDER</b></p> <p>Tenders and all documents in connection therewith, as specified above must be delivered in the addressed envelope which should be properly sealed and deposited at the offices as specified in the letter accompanying these documents or as indicated in the advertisement.</p> <p>Tenders will be opened at the time specified in the letter accompanying these Tender Documents or as indicated in the advertisement. Tenders delivered/received later than the above time will not be opened.</p>	
1.23	<p><b>VALUE ADDED TAX</b></p> <p>The Contractor’s attention is drawn to the Legal Notice in the Finance Act part 3 Section 21(b) operative from 1st September, 1993 which requires payment of VAT on all contracts.</p> <p>The Contractor should therefore include allowance in his rates and prices for prices for VAT and any other Government taxes currently in force.</p> <p>The tenderer is advised that in accordance with Government public notice No. 35 &amp; 36 Dated 11th September 2003 operational from 1st October 2003, VAT will be deducted against the contract sum at the prevailing rate by the Employer and remitted directly to the Commissioner of VAT through all interim certificates. It should however be noted that this is not additional tax but a new mode of payment for VAT, any excess payment will be refundable once the Contractor has submitted monthly returns to the Commissioner of VAT who will do the refunds when satisfied that the VAT regulations have been complied with.</p>	
	<p><b>NB: The Rates Quoted Should be Inclusive of VAT and not added at the Grand Summary Page</b></p>	
	<p><b>Carried to collection</b></p>	

Item	Description	Amount KSh
	<b><u>PROJECT MANAGERS EXPENSES</u></b>	
1.24	Provide Kenya Shillings , Two Hundred Thousand (KSh. 200,000.00) for Project Management expenses for Ministry of Lands, Public Works, Housing and Urban Development (State Department for Public Works - Nandi county) Officers.	
1.25	Allow for Contractor's profit and overheads (----- %)	
1.26	<b><u>PARTICULARS OF INSERTIONS TO BE MADE IN APPENDIX TO CONTRACT AGREEMENT</u></b>	
	The following are the insertions to be made in the appendix to the Contract Agreement: -	
	<b>Period of Final Measurement</b> 3 Months From Practical completion	
	<b>Defects Liability Period</b> 6 Months from Practical completion	
	<b>Date for Possession</b> To be agreed with the Project Manager	
	<b>Date for Completion</b> 24weeks from date of Possession	
	<b>Liquidated and Ascertained</b> At the rate of <b>KSh 0.005%</b> per day or part thereof	
	<b>Prime cost</b> sums for which The Contractor desires to tender .....	
	<b>Period of Interim Certificates</b> Monthly	
	<b>Period of Honouring Certificates</b> 30 days	
	<b>Percentage of Certified Value Retained</b> 10%	
	<b>Limit of Retention Fund</b> 10%	
	<b>Carried to collection</b>	<b>0.00</b>

<i>Item</i>	<i>Description</i>	<i>Amount KSh</i>
	<b><u>COLLECTION</u></b>	
	Brought forward from page 1/1	0.00
	Brought forward from page 1/2	0.00
	Brought forward from page 1/3	0.00
	Brought forward from page 1/4	0.00
	Brought forward from page 1/5	0.00
	<b>TOTAL FOR PARTICULAR PRELIMINARIES CARRIED TO GRAND SUMMARY</b>	<b>0.00</b>

<i>Item</i>	<i>Description</i>	<i>Amount KSh</i>
	<b>BILL NO. 2</b>	
	<b>GENERAL PRELIMINARIES</b>	
2.1	<b>PRICING ITEMS OF PRELIMINARIES AND PREAMBLES</b>	
	Prices will be inserted against items of Preliminaries in the Contractor's priced Bills of Quantities and Specification.	
	The Contractor shall be deemed to have included in his prices or rates for the various items in the Bills of Quantities or Specification for all costs involved in complying with all the requirements for the proper execution of the whole of the works in the Contract.	
2.2	<b>ABBREVIATIONS</b>	
	Throughout these Bills, units of measurement and terms are abbreviated and shall be all the requirements for the proper execution of the whole of the works in the Contract.	
	C.M.                      Shall mean cubic metre	
	S.M.                      Shall mean square metre	
	L.M.                      Shall mean linear metre	
	MM                        Shall mean Millimetre	
	Kg.                        Shall mean Kilogramme	
	No.                        Shall mean Number	
	Prs.                        Shall mean Pairs	
	B.S. - Shall mean the British Standard Specification Published by the British Standards Institution, 2 Park Street, London W.I., England.	
	Ditto - Shall mean the whole of the preceding description except as qualified in the description in which it occurs.	
	m.s.                        Shall mean measured separately.	
	a.b.d                        Shall mean as before described.	
	<b>Carried to collection</b>	

<i>Item</i>	<i>Description</i>	<i>Amount KSh</i>
2.3	<p><b>EXCEPTION TO THE STANDARD METHOD OF MEASUREMENT</b></p> <p>Attendance ; Clause B19(a) of the Standard Method of Measurement is deleted and the following clause is substituted:-</p> <p>Attendance on nominated Sub-Contractors shall be given as an item in each case shall be deemed to include: allowing use of standing scaffolding, mess rooms, sanitary accommodation and welfare facilities; provision of special scaffolding where necessary; providing space for office accommodation and for storage of plant and materials; providing light and water for their work: clearing away rubbish; unloading checking and hoisting; providing electric power and removing and replacing duct covers, pipe casings and the like necessary for the execution and testing of Sub- Contractors' work and being responsible for the accuracy of the same.</p> <p>Fix Only:-</p> <p>"Fix Only" shall mean take delivery at nearest railway station (Unless otherwise stated),pay all demurrage charges, load and transport to site where necessary, unload, store,unpack, assemble as necessary, distribute to position, hoist and fix only.</p>	
2.4	<p><b>EMPLOYER</b></p> <p>The Employer is NG-CDF CHESUMEI CONSTITUENCY</p> <p>The term "Employer","Procuring Entity","Government" and "NG-CDF CHESUMEI CONSTITUENCY" wherever used in the contract document shall be synonymous.</p>	
2.5	<p><b>PROJECT MANAGER</b></p> <p>The term "P.M." wherever used in these Bills of Quantities shall be deemed to imply the Project Manager as defined in Condition 1 of the Conditions of Contract. In this contract the project manager is the <b>Works Officer, State Department for Public Works, Nandi County</b></p>	
2.6	<p><b>ARCHITECT</b></p> <p>The term "Architect" shall be deemed to mean "The P.M." as defined above whose address unless otherwise notified is Works officer</p>	
2.7	<p><b>QUANTITY SURVEYOR</b></p> <p>The term "Quantity Surveyor" shall be deemed to mean "The P.M." as defined above whose address unless otherwise notified is Works officer</p>	
2.8	<p><b>ELECTRICAL ENGINEER</b></p> <p>The term "Electrical Engineer" shall be deemed to mean "The P.M." as defined above whose address unless otherwise notified is Works officer</p>	
	<p><b>Carried to collection</b></p>	

<b>Item</b>	<b>Description</b>	<b>Amount KSh</b>
2.9	<p><b>MECHANICAL ENGINEER</b></p> <p>The term "Mechanical Engineer" shall be deemed to mean "The P.M." as defined above whose address unless otherwise notified is Works officer</p>	
2.10	<p><b>STRUCTURAL ENGINEER</b></p> <p>The term "Structural Engineer" shall be deemed to mean "The P.M." as defined above whose address unless otherwise notified is Works officer, P.O. Box</p>	
2.11	<p><b>FORM OF CONTRACT</b></p> <p>The Form of Contract shall be as stipulated in the Republic of Kenya's Standard Tender Document for Building and Associated Civil Engineering Works (April 2022 Edition) included herein.</p> <p>The Conditions of Contract are also included herein</p> <p>Particulars of insertions to be made in the Appendix to the Contract Agreement will be found in the Particular Preliminaries part of these Bills of Quantities</p>	
2.12	<p><b>PERFORMANCE BOND.</b></p> <p>The Contractor shall find and submit on the Form of Tender an approved bank who will be willing to be bound to the Government in an amount equal to five per cent (5) of the Contract amount for the due performances of the Contract up to the date of completion as certified by the PROJECT MANAGER and who will, when and if called upon, sign a Bond to that effect on the relevant standard form included herein. (without the addition of any limitations) on the same day as the Contract Agreement is signed, by the Government, the Contractor shall furnish within seven days another Surety to the approval of the Government.</p>	
2.13	<p><b>PLANT, TOOLS AND VEHICLES</b></p> <p>Allow for providing all scaffolding, plant, tools and vehicles required for the works except in so far as may be stated otherwise herein and except for such items specifically and only required for the use of nominated Sub-Contractors as described herein. No timber used for scaffolding, formwork or temporary works of any kind shall be used afterwards in the permanent work.</p>	
2.14	<p><b>TRANSPORT.</b></p> <p>Allow for transport of workmen, materials, etc., to and from the site at such hours and by such routes as may be permitted by the competent authorities.</p>	
	<b>Carried to collection</b>	

<i>Item</i>	<i>Description</i>	<i>Amount KSh</i>
2.15	<p><b>MATERIALS AND WORKMANSHIP.</b></p> <p>All materials and workmanship used in the execution of the work shall be of the best quality and description unless otherwise stated. The Contractor shall order all materials to be obtained from overseas immediately after the Contract is signed and shall also ensure they are onsite when required for use in the works. The Bills of Quantities shall not be used for the purpose of ordering materials.</p>	
2.16	<p><b>SIGN FOR MATERIALS SUPPLIED.</b></p> <p>The Contractor will be required to sign a receipt for all articles and materials supplied by the PROJECT MANAGER at the time of taking deliver thereof, as having received them in good order and condition, and will thereafter be responsible for any loss or damage and for replacements of any such loss or damage with articles and/or materials which will be supplied by the PROJECT MANAGER at the current market prices including Customs Duty and V.A.T., all at the Contractor's own cost and expense, to the satisfaction of the PROJECT MANAGER</p>	
2.17	<p><b>STORAGE OF MATERIALS</b></p> <p>The Contractor shall provide at his own risk and cost where directed on the site weather proof lock-up sheds and make good damaged or disturbed surfaces upon completion to the satisfaction of the PROJECT MANAGER Nominated Sub-Contractors are to be made liable for the cost of any storage accommodation provided especially for their use.</p>	
2.18	<p><b>SAMPLES</b></p> <p>The Contractor shall furnish at his own cost any samples of materials or workmanship including concrete test cubes required for the works that may be called for by the PROJECT MANAGER for his approval until such samples are approved by the PROJECT MANAGER and the PROJECT MANAGER, may reject any materials or workmanship not in his opinion to be up to approved samples. The PROJECT MANAGER shall arrange for the testing of such materials as he may at his discretion deem desirable, but the testing shall be made at the expense of the Contractor and not at the expense of the PROJECT MANAGER. The Contractor shall pay for the testing in accordance with the current scale of testing charges laid down by the Ministry of Land, Housing and Urban</p> <p>The procedure for submitting samples of materials for testing and the method of marking for identification shall be as laid down by the PROJECT MANAGER The Contractor shall allow in his tender for such samples and tests except those in connection with nominated sub-contractors' work.</p>	
	<p><b>Carried to collection</b></p>	

<i>Item</i>	<i>Description</i>	<i>Amount KSh</i>
2.19	<p><b>GOVERNMENT ACTS REGARDING WORKPEOPLE ETC.</b></p> <p>Allow for complying with all Government Acts, Orders and Regulations in connection with the employment of Labour and other matters related to the execution of the works. In particular the Contractor's attention is drawn to the provisions of the Factory Act 1950 and his tender must include for all costs arising or resulting from compliance with any Act, Order or Regulation relating to Insurances, pensions and holidays for workpeople or so the safety, health and welfare of the workpeople.</p> <p>The Contractor must make himself fully acquainted with current Acts and Regulations, including Police Regulations regarding the movement, housing, security and control of labour, labour camps , passes for transport, etc. It is most important that the Contractor, before tendering, shall obtain from the relevant Authority the fullest information regarding all such regulations and/or restrictions which may affect the organisation of the works, supply and control of labour, etc., and allow accordingly in his tender. No claim in respect of want of knowledge in this connection will be entertained.</p>	
2.20	<p><b>SECURITY OF WORKS ETC.</b></p> <p>The Contractor shall be entirely responsible for the security of all the works stores, materials, plant, personnel, etc., both his own and sub-contractors' and must provide all necessary watching, lighting and other precautions as necessary to ensure security against theft, loss or damage and the protection of the public.</p>	
2.21	<p><b>PUBLIC AND PRIVATE ROADS.</b></p> <p>Maintain as required throughout the execution of the works and make good any damage to public or private roads arising from or consequent upon the execution of the works to the satisfaction of the local and other competent authority and the PROJECT MANAGER</p>	
2.22	<p><b>EXISTING PROPERTY.</b></p> <p>The Contractor shall take every precaution to avoid damage to all existing property including roads, cables, drains and other services and he will be held responsible for and shall make good all such damage arising from the execution of this contract at his own expense to the satisfaction of the PROJECT MANAGER</p>	
2.23	<p><b>VISIT SITE AND EXAMINE DRAWINGS.</b></p> <p>The Contractor is recommended to examine the drawings and visit the site the location of which is described in the Particular Preliminaries hereof. He shall be deemed to have acquainted himself therewith as to its nature, position, means of access or any other matter which, may affect his tender. No claim arising from his failure to comply with this recommendation will be considered.</p>	
	<p><b>Carried to collection</b></p>	

<i>Item</i>	<i>Description</i>	<i>Amount KSh</i>
2.24	<p><b>ACCESS TO SITE AND TEMPORARY ROADS.</b></p> <p>Means of access to the Site shall be agreed with the PROJECT MANAGER prior to commencement of the work and Contractor must allow for building any necessary temporary access roads for the transport of the materials, plant and workmen as may be required for the complete execution of the works including the provision of temporary culverts, crossings, bridges, or any other means of gaining access to the Site. Upon completion of the works, the Contractor shall remove such temporary access roads; temporary culverts, bridges, etc., and make good and reinstate all works and surfaces disturbed to the satisfaction of the PROJECT MANAGER The Contractor should also allow for relocating existing fence (approx. 30 metres long).</p>	
2.25	<p><b>AREA TO BE OCCUPIED BY THE CONTRACTOR</b></p> <p>The area of the site which may be occupied by the Contractor for use of storage and for the purpose of erecting workshops, etc., shall be defined on site by the PROJECT</p>	
2.26	<p><b>OFFICE ETC. FOR THE PROJECT MANAGER</b></p> <p>The Contractor shall provide, erect and maintain where directed on site and afterwards dismantle the site office of the standard type, complete with furniture. He shall also provide a strong metal trunk complete with strong hasp and staple fastening and two keys. He shall provide, erect and maintain a lock-up type water or bucket closet for the sole use of the PROJECT MANAGER including making temporary connections to the drain where applicable to the satisfaction of Government and Medical Officer of Health and shall provide services of cleaner and pay all conservancy charges and keep both office and closet in a clean and sanitary condition from commencement to the completion of the works and dismantle and make good disturbed surfaces. The office and closet shall be completed before the Contractor is permitted to commence the works. The Contractor shall make available on the Site as and when required by the "PROJECT MANAGER" a modern and accurate level together with levelling staff, ranging rods and 50 metre metallic or linen tape.</p>	
2.27	<p><b>WATER AND ELECTRICITY SUPPLY FOR THE WORKS</b></p> <p>The Contractor shall provide at his own risk and cost all necessary water, electric light and power required for use in the works. The Contractor must make his own arrangements for connection to the nearest suitable water main and for metering the water used. He must also provide temporary tanks and meters as required at his own cost and clear away when no longer required and make good on completion to the entire satisfaction of the PROJECT MANAGER . The Contractor shall pay all charges in connection herewith. No guarantee is given or implied that sufficient water will be available from mains and the Contractor must make his own arrangements for augmenting this supply at his own cost. Nominated Sub--contractors are to be made liable for the cost of any water or electric current used and for any installation provided especially for their own use.</p>	
	<p><b>Carried to collection</b></p>	

<i>Item</i>	<i>Description</i>	<i>Amount KSh</i>
2.28	<p><b>SANITATION OF THE WORKS</b></p> <p>The Sanitation of the works shall be arranged and maintained by the Contractor to the satisfaction of the Government and/or Local Authorities, Labour Department and the PROJECT MANAGER</p>	
2.29	<p><b>SUPERVISION AND WORKING HOURS</b></p> <p>The works shall be executed under the direction and to the entire satisfaction in all respects of the PROJECT MANAGER who shall at all times during normal working hours have access to the works and to the yards and workshops of the Contractor and sub-Contractors or other places where work is being prepared for the contract.</p>	
2.30	<p><b>PROVISIONAL SUMS.</b></p> <p>The term "Provisional Sum" wherever used in these Bills of Quantities shall have the meaning stated in Section A item A7(i) of the Standard Method of Measurement. Such sums are net and no addition shall be made to them for profit.</p>	
2.31	<p><b>PRIME COST (OR P.C.) SUMS.</b></p> <p>The term "Prime Cost Sum" or "P.C. Sum" wherever used in these Bills of Quantities shall have the meaning stated in Section A item A7 (ii) of the Standard Method of Measurement. Persons or firms nominated by the PROJECT MANAGER to execute work or to provide and fix materials or goods are described herein as Nominated Sub-Contractors. Persons or firms so nominated to supply goods or materials are described herein as Nominated Suppliers.</p>	
2.32	<p><b>PROGRESS CHART.</b></p> <p>The Contractor shall provide within two weeks of Possession of Site and in agreement with the PROJECT MANAGER a Progress Chart for the whole of the works including the works of Nominated Sub-Contractors ; one copy to be handed to the PROJECT MANAGER and a further copy to be retained on Site. Progress to be recorded and chart to be amended as necessary as the work proceeds.</p>	
2.33	<p><b>ADJUSTMENT OF P.C. SUMS.</b></p> <p>In the final account all P.C. Sums shall be deducted and the amount properly expended upon the PROJECT MANAGER'S order in respect of each of them added to the Contract sum. The Contractor shall produce to the PROJECT MANAGER such quotations, invoices or bills, properly receipted, as may be necessary to show the actual details of the sums paid by the Contractor. Items of profit upon P.C. Sums shall be adjusted in the final account pro-rata to the amount paid. Items of "attendance"</p> <p>Should the Contractor be permitted to tender and his tender be accepted of any work for which a P.C. Sum is included in these Bill of Quantities profit and attendance will be allowed at the same rate as it would be if the work were executed by a Nominated Sub-Contractor.</p>	
	<p><b>Carried to collection</b></p>	

<i>Item</i>	<i>Description</i>	<i>Amount KSh</i>
2.34	<p><b>ADJUSTMENT OF PROVISIONAL SUMS.</b></p> <p>In the final account all Provisional Sums shall be deducted and the value of the work properly executed in respect of them upon the PROJECT MANAGER's order added to the Contract Sum. Such work shall be valued as described for Variations, but should any part of the work be executed by a Nominated Sub-Contractor, the value of such work or articles for the work to be supplied by a Nominated Supplier, the value of such work or articles shall be treated as a P.C. Sum and profit and attendance comparable to that contained in the priced Bills of Quantities for similar items added.</p>	
2.35	<p><b>NOMINATED SUB-CONTRACTORS</b></p> <p>When any work is ordered by the PROJECT MANAGER to be executed by nominated sub-contractors, the Contractor shall enter into sub-contracts and shall thereafter be responsible for such sub-contractors in every respect. Unless otherwise described the Contractor is to provide for such Sub-Contractors any or all of the facilities described in these Preliminaries. The Contractor should price for these with the nominated Sub-contract Contractor's work concerned in the P.C. Sums under the description "add for Attendance".</p>	
2.36	<p><b>DIRECT CONTRACTS</b></p> <p>Notwithstanding the foregoing conditions, the Government reserves the right to place a "Direct Contract" for any goods or services required in the works which are covered by a P.C. Sum in the Bills of Quantities and to pay for the same direct. In any such instances, profit relative to the P.C. Sum the priced Bills of Quantities will be adjusted as described for P.C. Sums and allowed.</p>	
2.37	<p><b>ATTENDANCE UPON OTHER TRADESMEN, ETC.</b></p> <p>The Contractor shall allow for the attendance of trade upon trade and shall afford any tradesmen or other persons employed for the execution of any work not included in this Contract every facility for carrying out their work and also for use of his ordinary scaffolding. The Contractor, however, shall not be required to erect any special scaffolding for them. The Contractor shall perform such cutting away for and making good after the work of such tradesmen or persons as may be ordered by the PROJECT MANAGER and the work will be measured and paid for to the extent executed at rates provided in these Bills.</p>	
2.38	<p><b>INSURANCE</b></p> <p>The Contractor shall insure as required in Clause 18 of the Conditions of Contract. No payment on account of the work executed will be made to the Contractor until he has satisfied the PROJECT MANAGER either by production of an Insurance Policy or and Insurance Certificate that the provision of the foregoing Insurance Clauses have been complied with in all respects. Thereafter the PROJECT MANAGER shall from time to time ascertain that premiums are duly paid up by the Contractor who shall if called upon to do so, produce the receipted premium renewals for the PROJECT MANAGER's inspection.</p>	
	<p><b>Carried to collection</b></p>	

<i>Item</i>	<i>Description</i>	<i>Amount KSh</i>
2.39	<p><b>PROVISIONAL WORK</b></p> <p>All work described as "Provisional" in these Bills of Quantities is subject to remeasurement in order to ascertain the actual quantity executed for which payment will be made. All "Provisional" and other work liable to adjustment under this Contract shall left uncovered for a reasonable time to allow all measurements needed for such adjustment to be taken by the PROJECT MANAGER Immediately the work is ready for measuring, the Contractor shall give notice to the PROJECT MANAGER. If the Contractor makes default in these respects he shall if the PROJECT MANAGER so directs uncover the work to enable all measurements to be taken and afterwards reinstate at his own expense.</p>	
2.40	<p><b>ALTERATIONS TO BILLS, PRICING, ETC.</b></p> <p>Any unauthorised alteration or qualification made to the text of the Bills of Quantities may cause the Tender to be disqualified and will in any case be ignored. The Contractor shall be deemed to have made allowance in his prices generally to cover any items against which no price has been inserted in the priced Bills of Quantities. All items of measured work shall be priced in detail and the Tenders containing Lump Sums to cover trades or groups of work must be broken down to show the price of each item before they will be accepted.</p>	
2.41	<p><b>BLASTING OPERATIONS</b></p> <p>Blasting will only be allowed with the express permission of the PROJECT MANAGER in writing. All blasting operations shall be carried out at the Contractor's sole risk and cost in accordance with any Government regulations in force for the time being, and any special regulations laid down by the PROJECT MANAGER governing the use and storage of explosives.</p>	
2.42	<p><b>MATERIALS ARISING FROM EXCAVATIONS</b></p> <p>Materials of any kind obtained from the excavations shall be the property of the Government. Unless the PROJECT MANAGER directs otherwise such materials shall be dealt with as provided in the Contract. Such materials shall only be used in the works, in substitution of materials which the Contractor would otherwise have had to supply with the written permission of the PROJECT MANAGER Should such permission be given, the Contractor shall make due allowance for the value of the materials so used at a price to be agreed.</p>	
2.43	<p><b>PROTECTION OF THE WORKS.</b></p> <p>Provide protection of the whole of the works contained in the Bills of Quantities, including casing , casing up, covering or such other means as may be necessary to avoid damage to the satisfaction of the PROJECT MANAGER and remove such protection when no longer required and make good any damage which may nevertheless have been done at completion free of cost to the Government.</p>	
	<p><b>Carried to collection</b></p>	

<i>Item</i>	<i>Description</i>	<i>Amount KSh</i>
2.44	<p><b>REMOVAL OF RUBBISH ETC.</b></p> <p>Removal of rubbish and debris from the Buildings and site as it accumulates and at the completion of the works and remove all plant, scaffolding and unused materials at completion.</p>	
2.45	<p><b>WORKS TO BE DELIVERED UP CLEAN</b></p> <p>Clean and flush all gutters, rainwater and waste pipes, manholes and drains, wash (except where such treatment might cause damage) and clean all floors, sanitary fittings, glass inside and outside and any other parts of the works and remove all marks, blemishes, stains and defects from joinery, fittings and decorated surfaces generally, polish door furniture and bright parts of metalwork and leave the whole of the buildings watertight, clean, perfect and fit for occupation to the approval of the PROJECT MANAGER</p>	
2.46	<p><b>GENERAL SPECIFICATION.</b></p> <p>For the full description of materials and workmanship, method of execution of the work and notes for pricing, the Contractor is referred to the Ministry of Roads, Public Works and Housing General Specification dated 1976 or any subsequent revision thereof which is issued as a separate document, and which shall be allowed in all respects unless it conflicts with the General Preliminaries, Trade Preambles or other items in these Bills of Quantities.</p>	
2.47	<p><b>TRAINING LEVY</b></p> <p>The Contractor's attention is drawn to legal notice No. 237 of October, 1971, which requires payment by the Contractor of a Training Levy at the rate of 1/4 % of the Contract sum on all contracts of more than Kshs. 50,000.00 in value.</p>	
2.48	<p><b>MATERIALS ON SITE</b></p> <p>All materials for incorporation in the works must be stored on or adjacent to the site before payment is effected unless specifically exempted by the PROJECT MANAGER. This includes the materials of the Main Contractor, Nominated Sub-Contractors and Nominated Suppliers.</p>	
2.49	<p><b>HOARDING</b></p> <p>The Contractor shall enclose all the areas under construction with approved material to the satisfaction of the PROJECT MANAGER</p>	
	<p><b>Carried to collection</b></p>	

<i>Item</i>	<i>Description</i>	<i>Amount KSh</i>
2.50	<p><b>CONTRACTOR'S SUPERINTENDENCE/SITE AGENT</b></p> <p>The Contractor shall constantly keep on the works a literate English speaking Agent or Representative, competent and experienced in the kind of work involved who shall give his whole experience in the kind of work involved and shall give his whole time to the superintendence of the works. Such Agent or Representative shall receive on behalf of the Contractor all directions and instructions from the Project Manager and such directions shall be deemed to have been given to the Contractor in accordance with the Conditions of Contract.</p>	
	<b>Carried to collection</b>	
	<p style="text-align: center;"><b><u>COLLECTION</u></b></p> <p>Brought Forward From Page 2/1</p> <p>Brought Forward From Page 2/2</p> <p>Brought Forward From Page 2/3</p> <p>Brought Forward From Page 2/4</p> <p>Brought Forward From Page 2/5</p> <p>Brought Forward From Page 2/6</p> <p>Brought Forward From Page 2/7</p> <p>Brought Forward From Page 2/8</p> <p>Brought Forward From Page 2/9</p> <p>Brought Forward From Page 2/10</p> <p>Brought Forward From Above</p>	
	<p><b>TOTAL FOR GENERAL PRELIMINARIES CARRIED TO GRAND SUMMARY</b></p>	

<i>Item</i>	<i>Description</i>	<i>Q'ty</i>	<i>Unit</i>	<i>Rate</i>	<i>Amount KSh</i>
	<b>BILL NO. 3 - DIGITAL HUB</b>				
	<b><u>ELEMENT NO. 1</u></b>				
	<b><u>SUBSTRUCTURES (PROVISIONAL)</u></b>				
	<b><u>Site Preparation</u></b>				
1.1	Clear site of all bushes, shrubs, small trees, grub up roots and remove from site	237	Sm		
1.2	Cut down trees 600-900mm girth, ditto	1	No		
	<b><u>Excavations and Earthworks</u></b>				
	<i><u>Excavations including maintaining and supporting sides and keeping free from water, mud and fallen material</u></i>				
1.3	Oversite excavation 200 mm (average) depth to remove vegetable top soil; load and cart away spoil from site	237	Sm		
1.4	Excavation to reduce levels not exceeding 1.5 metres deep, starting from stripped levels; load and cart away spoil from site	237	Sm		
1.5	Excavate for trench foundations not exceeding 1.50 metres deep, starting from reduced levels	70	Cm		
1.6	Excavate pits for column bases not exceeding 1.50 metres deep, starting from reduced levels	14	Cm		
1.7	Extra over for excavation in rock of all classes	2	Cm		
	<i><u>Disposal</u></i>				
1.8	Return, fill and ram selected excavated material around foundations.	40	Cm		
1.10	Load, wheel and deposit surplus excavated material away from site	44	Cm		
	<i><u>Hardcore or other approved filling, as described</u></i>				
1.11	Imported fill material in filling to make up levels, compacted in layers not exceeding 150 mm thick with a vibratory roller to the satisfaction and approval of the Structural Engineer (S.E)	62	Cm		
1.12	300mm thick handpacked h/core material in filling to make up levels, and well compacted in 150mm thick layers to structural Engineer's approval.	208	Sm		
	<b>Carried to Collection</b>				

<b>Item</b>	<b>Description</b>	<b>Q'ty</b>	<b>Unit</b>	<b>Rate</b>	<b>Amount KSh</b>
1.13	50 mm thick quarry dust or approved murrum blinding layer to surfaces of hardcore m.s	208	Sm		
	<b><u>Anti - termite treatment</u></b>				
1.14	Chemical anti-termite treatment as <i>Termidor 96 SC</i> or approved equivalent, executed complete by an approved specialist under a ten-year guarantee, to surfaces of hardcore (m/s)	208	Sm		
	<b><u>Damp-proof membrane</u></b>				
1.15	1000 gauge polythene or other equal and approved damp-proof membrane, laid over blinded hardcore (m/s) with 300mm side and end laps (measured net - allow for laps).	208	Sm		
	<b><u>Concrete works</u></b>				
	<i><u>Plain concrete class 15: in</u></i>				
1.16	50 mm thick blinding under strip foundations	59	Sm		
1.17	50 mm thick blinding under column bases	12	Sm		
	<i><u>Vibrated Reinforced Concrete class 25/20: as described in</u></i>				
1.18	Strip footings	12	Cm		
1.19	Column bases	3	Cm		
1.20	Columns	1	Cm		
1.21	150 mm Thick Surface beds	206	Sm		
1.22	Ditto; to sloping ramp slabs	2	Sm		
1.23	Steps	1	Cm		
	<b><u>Reinforcement (Provisional)</u></b>				
	<i><u>High yield steel ribbed reinforcement bars to K.S 573:2005; including all binding wires and spacer blocks; cutting, bending and laying to Structural Engineer's approval: as described to:-</u></i>				
1.24	Assorted bars	348	Kg		
	<i><u>Steel mesh fabric reinforcement to BS 4483 and setting in concrete with 300mm side and end laps (measured net - allow for laps):</u></i>				
1.25	Reference A142 mesh 200mm x 200mm, weight 2.22kgs per square meter [measured net – no allowance made for laps [including bends, tying wire and distance blocks	208	Sm		
	<b>Carried to Collection</b>				

<b>Item</b>	<b>Description</b>	<b>Q'ty</b>	<b>Unit</b>	<b>Rate</b>	<b>Amount KSh</b>
	<b><u>Formwork</u></b>				
	<i>Sawn formwork: including erection and making good all exposed faces of concrete after stripping off formwork; as described to:-</i>				
1.26	Vertical sides of strip footings	39	Sm		
1.27	Vertical sides of column bases	12	Sm		
1.28	Vertical sides of columns	13	Sm		
1.29	Edges; over 75 mm but not exceeding 150 mm high, to slab	59	Lm		
1.30	Ditto: but sloping, to ramps	7	Lm		
1.31	Ditto: to edges of steps	9	Lm		
	<b><u>Foundation walling</u></b>				
	<i>Natural hard chisel dressed quarry stone with a crushing strength of 7.5 N/mm<sup>2</sup>; walling bedded and jointed in cement and sand (1:4) mortar, reinforcement with and including 25mm wide x 20 gauge hoop iron at every alternate course: as described to</i>				
1.32	200 mm thick foundation walling	117	Sm		
	<b><u>Plinth finishes</u></b>				
	<i>Render/backings: 15 mm thick coat of cement/sand (1:3) mortar: wood floated: on masonry or concrete surfaces: as described to</i>				
1.33	Concrete and masonry surfaces externally; finished smooth	35	Sm		
	<i>Prepare surfaces and apply three coats of first quality Black Bituminous paint as supplied by "Crown Paints" or approved equivalent: as described on</i>				
1.34	Rendered surfaces, externally	35	Sm		
	<b>Carried to Collection</b>				





Item	Description	Q'ty	Unit	Rate	Amount KSh
	<b><u>ELEMENT NO. 3</u></b>				
	<b><u>WALLING</u></b>				
	<b><u>External Walling</u></b>				
	<i>Natural hard machine cut stone, bedded and jointed in cement and sand (1:4) mortar, reinforcement with and including 25mm wide x 20 gauge hoop iron at every alternate course: as described to</i>				
3.1	200 mm thick walling	210	Sm		
	<i>Hessian based bituminous felt 3-ply membrane damp proof course or other equal approved damp-proof course; laid on and including cement and sand (1:4) mortar; as described to</i>				
3.2	200 mm wide; levelled and bedded under wall	87	Lm		
	<i>Precast concrete grade 20(12mm aggregate) including formwork, finishing fair on all exposed surfaces and hoisting and placing in position, bedding, jointing and pointing in cement and sand (1:3) mortar</i>				
3.3	250 x 75mm weathered and throated precast concrete coping bedded in c/s mortar 1:3		Lm		
	<b><u>Internal Walling</u></b>				
	<i>Natural hard machine cut stone, bedded and jointed in cement and sand (1:4) mortar, reinforcement with and including 25mm wide x 20 gauge hoop iron at every alternate course as described in:</i>				
3.4	200 mm thick walling	69	Sm		
3.5	150 mm thick walling	9	Sm		
3.6	100 mm thick walling	19	Sm		
	<i>Hessian based bituminous felt 3-ply membrane damp proof course or other equal approved damp-proof course; laid on and including cement and sand (1:4) mortar; as described to</i>				
3.7	200 mm wide; levelled and bedded under wall	17	Lm		
3.8	Ditto: 150 mm wide	3	Lm		
3.9	Ditto: 100 mm wide	9	Lm		
	<b><u>ELEMENT NO. 3</u></b>				
	<b><u>WALLING</u></b>				
	<b>Carried to Main Summary</b>				

<i>Item</i>	<i>Description</i>	<i>Q'ty</i>	<i>Unit</i>	<i>Rate</i>	<i>Amount KSh</i>
	<b><u>ELEMENT NO. 4</u></b>				
	<b><u>ROOFING AND RAINWATER DISPOSAL</u></b>				
	<b><u>Roof Structure (Provisional)</u></b>				
	<b><u>Structural timbers: sawn cypress: celcure treated</u></b>				
	<i><u>The following in pressure impregnated first grade cypress timber trusses, nailed connections, hoisting 3.5m above ground</u></i>				
4.1	150 x 50 mm Rafters	233	Lm		
4.2	150 x 50 mm Ceiling joists	158	Lm		
4.3	150 x 50 mm king post	0	Lm		
4.4	100 x 50 mm Struts and ties	242	Lm		
4.5	150 x 25 mm Ridge board	23	Lm		
	<i><u>The following in pressure impregnated first grade cypress timber</u></i>				
4.6	100 x 50mm wall plate rag-bolted at 1200mm centres with hoop iron	62	Lm		
4.7	75 x 50 mm Purlins	318	Lm		
4.8	150 x 50 mm Valley Rafters	47	Lm		
	<b><u>Eaves Finishes</u></b>				
	<i><u>General joinery: wrot cypress or equal and approved: selected and kept clean</u></i>				
4.9	25mm thick tounge & groove ceiling secret nailed complete with and including 50 x 50mm frames		Sm		
4.10	100 x 25 mm cornice, in two labors; plugged		Lm		
4.11	Size 225 x 27mm Thick fascia board fixed to ends of trusses; horizontal	67	Lm		
	<b>Carried to Collection</b>				



<b>Item</b>	<b>Description</b>	<b>Q'ty</b>	<b>Unit</b>	<b>Rate</b>	<b>Amount KSh</b>
	<b><u>ELEMENT NO.5</u></b>				
	<b><u>DOORS</u></b>				
	<b><u>Frames and Linings</u></b>				
	<i>Frames in wrot hardwood: prime grade</i>				
5.1	150 x 50mm frame with two labours plugged	60	Lm		
5.2	Ditto: to transome	7	Lm		
5.3	50 x 25mm architrave with two labours, plugged	60	Lm		
5.4	25mm dia. quadrant beading	60	Lm		
5.5	20 x 15mm glazing beading	16	Lm		
	<i>45mm thick Solid core <b>flush door</b> to B.S 459: Part 2 ; faced both sides with 6mm embossed mahogany veneered plywood and lipped on all edges in hardwood, including all planted moulding</i>				
5.6	Door size 900 x 2100 mm high	4	No		
5.7	Door size 1800 x 2100 mm high	2	No		
5.8	Door size 800 x 2100 mm high; semi-solid to washroom WC doors	3	No		
	<b><u>Metal Doors</u></b>				
	<i>Purpose made Mild steel door: comprising 75mm x 50mm x 3 mm thick SHS frame fishtail grouted into concrete or masonry walling with 100mm mild steel anchors; 50mm x 25mm x 3 mm SHS frames and rails at 300mm centres door leaf covered with 3mm thick mild steel sheets on both sides;all welding ground to smooth finish and including priming metal surfaces with zinc chromate primer before delivery to site and three coats gloss oil automotive spray paint finish;; supplying and fixing 3no. heavy duty hinges per door leaf, brass finish to back handle and 5 lever "union" mortise lock; a all to architect's approval and detail drawings</i>				
5.9	Door: Overall Size 1800 x 2400 mm high, in two equal leaves each size 600 x 2100 mm high; including 1200 x 300 mm high fixed fanlight; complete with purpose made heavy duty steel hinges, hasp locks, tower bolts, etc all as necessary; door completed to Architectural design and details; externally	1	No		
	<b>Carried to Collection</b>				

<i>Item</i>	<i>Description</i>	<i>Q'ty</i>	<i>Unit</i>	<i>Rate</i>	<i>Amount KSh</i>
	<b><u>Ironmongery</u></b>				
	<i>Supply and fix the following ironmongery to 'Union' catalogue supplied by 'Assa Abloy' or other equal and approved complete with matching screws: as described to</i>				
5.10	Pair 150 mm brass butt hinges	17	Prs.		
5.11	5-lever security door lock, rebated fore end complete with handles	0	No		
5.12	Steel door lock complete with handles	2	No		
5.13	Three lever mortice lock complete with Martin aluminium handles	7	No		
5.14	Two lever mortice bathroom door lock complete with Martin aluminium handles	0	No		
5.15	Disabled lockset	0	No		
5.16	Indicator bolt vacant/engaged	4	No		
5.17	150 mm tower bolt, stainless steel	4	No		
5.18	Male, female and PWD signs, brass	2	No		
5.19	Coat and hat hook with rubber tip, aluminium	11	No		
5.20	Rubber door stop; fixed to floor or wall in rawl bolt	15	No		
	<b><u>Glazing</u></b>				
	<i>Skylight panes in 4 mm thick clear sheet glass: to</i>				
5.21	Panes not exceeding 0.1 square metres; fixed and held to position in h/w beading (m/s); to fanlight	1	Sm		
5.22	Panes not exceeding 0.1 square metres; fixed to m.s door casement members in metal putty	2	Sm		
	<b>Carried to Collection</b>				

<i>Item</i>	<i>Description</i>	<i>Q'ty</i>	<i>Unit</i>	<i>Rate</i>	<i>Amount KSh</i>
	<b><u>Painting and decoration</u></b>				
	<i><u>Knot, prime, stop and apply two coats of prime grade quality polyurethane clear varnish paint as "Crown Paints" or approved equivalent: to wood surfaces: as described to</u></i>				
5.23	General surfaces of wooden doors ( <i>measured on both sides</i> )	47	Sm		
5.24	Surfaces over 200 mm but not exceeding 300 mm girth	67	Lm		
5.25	Surfaces over 100 mm but not exceeding 200 mm girth	137	Lm		
	<i><u>Prepare and apply two finishing coats of super gloss finished paint as "Crown Paints" or other equal and approved paint to:</u></i>				
5.26	General surfaces of metal doors ( <i>measured on both sides</i> )	17	Sm		
	<b>Carried to Collection below</b>				
	<b><u>Collection Page</u></b>				
	From Page 3/10				
	From Page 3/11				
	From Page Above				
	<b><u>ELEMENT NO. 5</u></b>				
	<b>DOORS</b>				
	<b>Main Summary</b>				

<b>Item</b>	<b>Description</b>	<b>Q'ty</b>	<b>Unit</b>	<b>Rate</b>	<b>Amount KSh</b>
	<b><u>ELEMENT NO. 6</u></b>				
	<b><u>WINDOWS</u></b>				
	<b><u>Window Cill</u></b>				
	<i><u>Precast concrete class 20 fair faced all exposed surfaces bedded and jointed cement and sand (1:3) mortar</u></i>				
6.1	Size 175 x 75 mm thick window cill once rebated and throated; laid and jointed in cement and sand (1:3) mortar	35	Lm		
	<b><u>Curtain rods</u></b>				
6.2	Mild steel curtain rods: complete and comprising 2No. rods of 32 mm diameter and 25 mm diameter complete with fixing brackets, rings and decorative ends; finished in automotive spray paint	20	Lm		
	<b><u>Steel Casement Windows</u></b>				
	<i><u>Supply and fix the following purpose made heavy duty steel casement windows in standard Z sections: incorporating hooded mosquito proofed permanent vent along the top edge: pin type hinges: including all necessary cutting, welding and grinding: ironmongery as 'Kensmetal': hinges, fasteners and window stays: one coat aluminium grey primer before fixing: all to Architect's schedule; as described to</u></i>				
	<i><u>Note: Window divided by „T" sections to form small grids average size 300 x 300mm or as specified including 25mm wide x 3mm thick burglar proofing flats welds to window running along grids of small pane divisions; all welding ground smooth to Architect's detail</u></i>				
6.3	Window overall size: 1200 x 1900mm high	22	No		
6.4	Window overall size: 900 x 600mm high	5	No		
	<b><u>Glazing</u></b>				
	<i><u>Window panes in 4 mm thick clear sheet glass: to</u></i>				
6.5	Panes not exceeding 0.1 square metres; fixed to m.s window members in approved metal putty	54	Sm		
6.6	Ditto: but to obscure sheet glass: to washroom windows	2	Sm		
	<b>Carried to Collection</b>				

<i>Item</i>	<i>Description</i>	<i>Q'ty</i>	<i>Unit</i>	<i>Rate</i>	<i>Amount KSh</i>
	<b><u>Painting &amp; Decoration</u></b>				
	<i>Prepare and apply two finishing coats of super gloss finished paint as "Crown Paints" or other equal and approved paint to:</i>				
6.7	General surfaces of metal windows ( <i>measured on both sides</i> )	111	Sm		
	<b><u>Burglar-proof Grilles:</u></b>				
6.8	Burglar-proofing grilles consisting of 25 x 25 x 2 mm thick SHS frame and grille at 150mm centres all round infilled . All connections welded and ground smooth including fixing the whole unit 50 mm away from glazing face; to <i>all external windows</i>		Sm		
	<b>Carried to Collection below</b>				
	<b><u>Collection Page</u></b>				
	From Page 3/13				
	From Page Above				
	<b><u>ELEMENT NO. 6</u></b>				
	<b><u>WINDOWS</u></b>				
	<b>Carried to Main Summary</b>				

<b>Item</b>	<b>Description</b>	<b>Q'ty</b>	<b>Unit</b>	<b>Rate</b>	<b>Amount KSh</b>
	<b><u>ELEMENT NO. 7</u></b>				
	<b><u>EXTERNAL FINISHES</u></b>				
	<b><u>External wall finishes</u></b>				
	<i>Render/backings: 15 mm coat of cement/sand (1:3) mortar: wood floated: on exposed masonry or concrete surfaces: to</i>				
7.1	Concrete or masonry surfaces externally; finished smooth	118	Sm		
7.2	Moulded concrete columns surfaces externally; finished smooth	2	Sm		
	<i>Key pointing to horizontal joints and flushing to vertical joints; in cement and sand (1:3) mortar: painted in approved exterior paint as described to</i>				
7.3	Masonry surfaces externally; finished smooth	531	Sm		
	<b><u>Painting and decorating</u></b>				
	<i>Prepare surfaces, skim and apply three coats of Permacote Ultra Guard (with Silicone) exterior paint as supplied by "Crown Paints" or approved equivalent: as described on</i>				
7.4	Rendered concrete surfaces, externally approved colours	119	Sm		
	<b><u>Floor Finishes</u></b>				
	<i>Cement and sand (1:3) mortar: to screeds, backings, beds etc: in</i>				
7.5	25 mm thick screeds to receive terrazzo floor (m/s); including plastic dividing strips cast in screeds	18	Sm		
	<i>15 mm thick polished terrazzo paving in approved coloured aggregates: mixed with white cement and laid in between plastic dividing strips placed to recommended spacings: on screed backings (m.s); ground and polished to approval: as described: to</i>				
7.6	General surfaces of floors	18	Sm		
7.7	Skirting, 150 mm high	19	Lm		
	<b>Carried to Collection</b>				



<b>Item</b>	<b>Description</b>	<b>Q'ty</b>	<b>Unit</b>	<b>Rate</b>	<b>Amount KSh</b>
	<b><u>ELEMENT NO. 8</u></b>				
	<b><u>INTERNAL FINISHES</u></b>				
	<b><u>Wall Finishes</u></b>				
	<i><u>12mm thick plaster: 9 mm first coat of cement/sand (1:6): 3mm second coat of cement/lime/putty (1:6): steel trowelled: as described to</u></i>				
8.1	Concrete and masonry surfaces, internally	419	Sm		
8.2	Jambs and reveals: 100 - 200 mm girth	204	Lm		
	<i><u>Cement and sand (1:3) mortar: to screeds, backings, beds etc</u></i>				
8.3	15mm Thick backings to receive ceramic wall tiles (m/s)	88	Sm		
	<i><u>Supply and fix coloured glazed ceramic wall tiles as supplied by SAJ CERAMICS or approved equivalent: bedding and jointing in approved tile adhesive: joints in 2mm spacers and pointed in matching colour grout: as described to:-</u></i>				
8.4	300 x 600 x 6mm Thick tiles: on screed backings (m/s)	13	Sm		
	<b><u>Painting and decoration</u></b>				
	<i><u>Prepare surfaces, skim and apply one undercoat and two final coats of first quality <b> matt emulsion </b> paint as "Crown Paints" or approved equivalent: as described on</u></i>				
8.5	Plastered surfaces, internally	419	Sm		
8.6	Jambs and reveals: 100 - 200 mm girth	204	Lm		
	<b><u>Floor Finishes</u></b>				
	<i><u>Cement and sand (1:3) mortar: to screeds, backings, beds etc: in</u></i>				
8.7	32 mm Thick bed screed to receive ceramic floor tiles (m/s)	17	Sm		
8.8	25 mm thick screeds to receive terrazzo floor (m/s)	171	Sm		
8.9	Provide 15mm thick terrazzo layer	171	Sm		
	32 x 3 mm thick plastic dividing strips	300	Lm		
	Skirting; 100mm wide with rounded junction with wall finish and straight junction with floor finish	80	Sm		
	<i><u>Supply and fix the following coloured non-slip ceramic floor tiles: as supplied by "SAJ Ceramics" or other equal and approved: laid on prepared screed (m/s) in approved adhesive : joints pointed in matching cement grout: as described to:-</u></i>				
8.10	8mm thick tiles: on screed (m.s)	17	Sm		
8.11	Ditto: Skirting, 100 mm high; finished fair at top edge	21	Lm		
	<b>Carried to Collection</b>				

<b>Item</b>	<b>Description</b>	<b>Q'ty</b>	<b>Unit</b>	<b>Rate</b>	<b>Amount KSh</b>
	<b><u>Ceiling Finishes</u></b>				
	<i>Chipboard ceiling nailed to 50 x 50mm timber branderling fixed horizontally at 600mm centres both ways; with neat finishing to V-joints: as described to</i>				
8.12	12 mm thick boards, laid horizontally:	206	Sm		
8.13	Extra over ceiling for trap door size 600x450mm wide with and including 50x50mm timber framing all round	1	No		
	<i>Wrot cypress timber: prime grade</i>				
8.14	100 x 25 mm cornice, in two labors; plugged	171	Lm		
	<b><u>Painting and decoration</u></b>				
	<i>Prepare surfaces, skim and apply one undercoat and two final coats of brilliant white plastic emulsion paint as "Crown Paints" or approved equivalent: as described on</i>				
8.15	Ceiling surfaces, internally	206	Sm		
8.16	Wooden surfaces of cornice; 100 - 200 mm girth	171	Lm		
8.17	Plastered surfaces, internally	419	Sm		
	<b>Carried to Collection</b>				
	<b><u>Collection Page</u></b>				
	From Page 3/17				
	From Page Above				
	<b><u>ELEMENT NO. 8</u></b>				
	<b>FINISHES</b>				
	<b>Carried to Main Summary</b>				

<i>Item</i>	<i>Description</i>	<i>Q'ty</i>	<i>Unit</i>	<i>Rate</i>	<i>Amount KSh</i>
	<b><u>ELEMENT NO. 9</u></b>				
	<b><u>FITTINGS &amp; FIXTURES (PROVISIONAL)</u></b>				
	<b><u>Reception desk</u></b>				
	<i>Supply and fix the following worktops; consisting of 75mm thick reinforced concrete worktop finished in 18mm thick marble top and reinforced in BRC Mesh A98; 100mm thick vertical masonry wall supports, complete in cement/sand plaster; 100mm thick mass concrete plinth complete in cement/sand plaster; 20mm thick plain blockboards in horizontal and vertical divisions; doors and drawer faces finished fair and in approved pattern, complete with all necessary ironmongery to include mapler hinges, cabinet cylinder locks, handles, etc; cut worktop for cooker, sinks, taps, etc as necessary: spray painted in eggshel oil paint: all to Architectural details and approval: as described to</i>				
9.1	Worktop: overall size 2000 x 700 x 900 mm high; to Reception areas	1	No		
	<b><u>Pin boards</u></b>				
9.2	Pinboard, wall-hung: Overall size 2400 x 1200 mm high; in 12 mm thick softboard, white; 75 x 25 mm h/w framing; prime, sand and finish frame in gloss oil paint to approval	1	Item		
	<b><u>Signage</u></b>				
9.3	Allow a provisional sum of KSh. 25,000.00 for signage				
	<b><u>ELEMENT NO. 9</u></b>				
	<b><u>FITTINGS AND FIXTURES</u></b>				
					<b>Carried to Main Summary</b>

<i>Item</i>	<i>Description</i>	<i>Q'ty</i>	<i>Unit</i>	<i>Rate</i>	<i>Amount KSh</i>
	<b><u>SUMMARY</u></b>				
1	Substructure (Provisional)	3/4			
2	R.C. Superstructure	3/5			
3	Walling	3/6			
4	Roofing and Rainwater Disposal	3/9			
5	Doors	3/12			
6	Windows	3/14			
7	External Finishes	3/16			
8	Internal Finishes	3/18			
9	Joinery Fittings And Fixtures	3/19			
	<b><u>BILL NO. 3 - ICT HUB</u></b>				
	<b><u>CARRIED TO THE GRAND SUMMARY</u></b>				

<b>Item</b>	<b>Description</b>	<b>Q'ty</b>	<b>Unit</b>	<b>Rate</b>	<b>Amount KSh</b>
	<b><u>BILL NO. 4 ELECTRICAL INSTALLATIONS</u></b>				
	<i>Supply, install, test and commission the following items:</i>				
1.0	<b>LIGHTING</b>				
1.1	Lighting points wired in 3 x 1.5mm <sup>2</sup> PVC/SC CU cables drawn in 20mm-Ø concealed HG PVC conduits complete with all necessary accessories but excluding switches for: -				
	a) One way switching.	27	NO		
	b) Two way switching.	0	NO		
2.0	<b>LIGHTING SWITCHES</b>				
2.1	10A, moulded ivory white switch plates as MK Range or approved equivalent as follows;				
	a) 1 gang 2 way.	4	NO		
	b) 2 gang 2 way.	0	NO		
3.0	<b>AUTOMATIC SWITCHING</b>				
3.1	a) 240V, 63A DP-Pole MCB complete with mounting plastic box, mounting rail and all other accessories as Telemecanique or approved equivalent: -	1	NO		
3.2	b) 5A photocell as Thorn QPK or approved equivalent.	1	NO		
4.0	<b>LIGHTING FITTINGS</b>				
4.1	Lighting fittings complete with lamps of appropriate wattage and colour rendering and fixing materials as follows: -				
	a) Type - EXIT	2	NO		
	b) 600mm, ceiling louver fitting complete with 4x18W, T8 LED daylight Tube as Osram or approved equivalent.	3	NO		
	c) 1200mm, bare batten complete with 1x16W, T8 LED day light Tube light as Osram or approved equivalent.	19	NO		
	d) 1200mm, lighting fitting complete with 1x18W, T8 LED Tube lamp, day light as Thom Aqua proof or approved equivalent.	1	NO		
	e) Surface mounted bulkhead with die cast aluminium body and opal polycarbonate diffuser, IP65, oval shape with visor complete with 8W, LED lamps as Thom Roller or approved equivalent	3	NO		
5.0	<b>POWER POINTS</b>				
5.1	Raw power socket outlet power points wired in Ring Mains using 3 x 2.5 mm <sup>2</sup> PVC/SC CU cables drawn in 25mmØ HGPVC conduits including all conduit accessories but excluding plates: -				
	a) Single outlet	0	NO		
	b) Twin outlet	12	NO		
5.2	13A, moulded ivory white switched socket outlet plates as MK Range or approved equivalent as follows:				
	i) Single switched	0	NO		
	ii) Twin switched	12	NO		
	Sub-total carried forward to summary page				

<b>Item</b>	<b>Description</b>	<b>Q'ty</b>	<b>Unit</b>	<b>Rate</b>	<b>Amount KSh</b>
6.0	<b>ELECTRICAL SERVICES</b>				
6.1	Lay HG/PVC conduits for electrical services concealed in the building fabric:				
	a) 20mmØ.	50	M		
	b) 25mmØ.	25	M		
	c) 32mmØ.	20	M		
7.0	<b>TRUNKING</b>				
7.1	<b>WALL TRUNKING:</b> - Lay 100X50mmHG/PVC twin trunking to be powder coated and white in colour complete with all necessary accessories around all external walls.		M		
8.0	<b>INTERNAL POWER DISTRIBUTION</b>				
8.1	Supply, install, test and commission consumer units/power distribution boards as that manufactured by Merlin GERIN or equal and approved equivalent as described below: -				
	a) 63A, 6-Way SPN+E Consumer Unit.	1	NO		
	b) SP/DP MCB's for DB above as follows: -				
	i) 10A SP MCB	3	NO		
	ii) 20A SP MCB	6	NO		
	iii) 30A SP MCB		NO		
	iv) Blanking plate	1	NO		
9.0	<b>SUB-MAIN CABLES &amp; ELECTRICAL SERVICES DUCT;</b>				
9.1	Lay 10.0 mm <sup>2</sup> 2-CPVC/SWA/PVC copper cable c/w appropriate cable lugs and glands from the meter box to the CLB box complete with concrete cable route markers Marked "P" to engineers' approval.	25	LM		
9.2	<b>Submains Cable:</b> 2x6.0 mm <sup>2</sup> SC/PVC CU cable (red and black) drawn in 32mm-Ø concealed HG PVC conduits complete with all necessary accessories from CLB to Consumer Unit.	25	LM		
9.3	<b>METER BOX;</b> - 500x400x300mm meter box complete with; -	1	NO		
	a) 80A cut-out fitting as per or approved.	1	NO		
9.4	<b>Cable Loop-in Boxes (CLB):</b> Standard cable loop-in box complete with the following to engineers' approval: -	1	NO		
	a) 240V, 63A DP-Pole MCB as Schneider or approved equivalent complete with mounting rail and all other accessories.	1	NO		
9.5	<b>Trenching:</b> - Trenching at an average depth of 750mm, duct & cable laying, laying and backfilling for the above cable to engineers' approval.	25	LM		
	Sub-total carried forward to summary page				

<b>Item</b>	<b>Description</b>	<b>Q'ty</b>	<b>Unit</b>	<b>Rate</b>	<b>Amount KSh</b>
10.0	<b>LIGHTENING PROTECTION</b> Lightening protection system comprising of; - a) 25mmx3mm copper tape. b) Copper saddles c) 600mm aerial copper rod complete with spikes and base. d) Circular 4-way clamps. e) Precast inspection chamber complete with cover.	15 4 1 4 1	M NO NO NO NO		
11.0	<b>EARTHING</b> a) 300 x 300 x 300mm concrete earthing chamber complete with concrete cover. b) Earth rod (16mm Ø 1500mm long) with Earth-rod- cable clamp and Driving Head for Earth rod. c) 6.0mm <sup>2</sup> SC/PVC CU cable (yellowgreen) earth lead drawn in 20mm-Ø HG/PVC conduit from the meterboards to the earth pit.	1 1 10	NO NO LM		
12.0	Allow for testing and commissioning the works to the Project Manager approval.		SUM		
	Sub-total carried forward to summary page				
	<b><u>SUMMARY PAGE</u></b>  From page 4/1  From page 4/2  From page ABOVE				
	<b>TOTAL FOR ELECTRICAL INSTALLATIONS CARRIED TO GRAND SUMMARY</b>				

<b>BILL NO.5 MECHANICAL INSTALLATIONS</b>					
<b>SUBCONTRACT PRELIMINARIES</b>					
<i>Item</i>	<i>Description</i>	<i>Q'ty</i>	<i>Unit</i>	<i>Rate</i>	<i>Amount (Kshs)</i>
	<b>PRELIMINARIES</b>				
	<b>Scope of Contract Works</b>				
A	The contractor shall supply, deliver, unload, hoist, fix, test, commission and hand-over in satisfactory working order the complete installations specified hereinafter and/or as shown on the Contract Drawings attached hereto, including the provision of labour, transport and plant for unloading material and storage, and handling into position and fixing, also the supply of ladders, scaffolding the other mechanical devices to plant, installation, painting, testing, setting to work, the removal from site from time to time of all superfluous material and rubbish caused by the works.		Item		0.00
	<b>Firm price contract</b>				
B	This is a firm-price Contract and the contractor must allow in his tender for the increase in the cost of labour and/or materials during the duration of the contract. No claims will be allowed for increased costs arising from the fluctuations in duties and/or day to day currency fluctuations. The Sub-contractor will be deemed to have allowed in his tender for any increase in the cost of materials, which may arise as a result of currency fluctuation during the contract period.		Item		0.00
	<b>Bond</b>				
C	The tenderer must submit with his tender the name of one Surety who must be an established Bank only who will be willing to be bound to the Government for an amount equal to 5 % of the Contract amount		Item		0.00
	<b>Government Legislation and Regulations</b>				
D	The Contractor's attention is called to the provision of the Factory Act 1972 and subsequent amendments and revisions, and allowance must be made in his tender for compliance therewith, in so far as they are applicable.  The Contractor must also make himself acquainted with current legislation and any Government regulations regarding the movement, housing, security and control of labour, labour camps, passes for transport, etc.		Item	0	0.00
	<b>Import Duty and Value Added Tax</b>				
E	The contractor will be required to pay full Import Duty and Value Added Tax on all items of equipment, fittings and plant, whether imported or locally manufactured. The tenderer shall make full allowance in his tender for all such taxes.		Item	0	0.00
	<b>Total cost carried forward to collection page</b>				<b>0.00</b>

<i>Item</i>	<i>Description</i>	<i>Q'ty</i>	<i>Unit</i>	<i>Rate</i>	<i>Amount (Kshs)</i>
A	<p><b>Insurance Company Fees</b></p> <p>Attention is drawn to the tenderers to allow for all necessary fees, where known, that may be payable in respect of any fees imposed by Insurance Companies or statutory authorities for testing or inspection.</p>		Item	0	0.00
B	<p><b>Samples and Materials Generally</b></p> <p>The Contractor shall, when required, provide for approval at no extra cost, samples of all materials to be incorporated in the works. Such samples, when approved, shall be retained by the Engineer and shall form the standard for all such materials incorporated.</p>		Item		0.00
C	<p><b>Builder's Work</b></p> <p>All chasing, cutting away and making good will be done by the Contractor. The Contractor shall mark out in advance and shall be responsible for accuracy of the size and position of all holes and chases required.</p> <p>The Contractor shall drill and plug holes in floors, walls, ceiling and roof for securing services and equipment requiring screw or bolt fixings.</p> <p>Any purpose made fixing brackets shall be provided and installed by the Contractor</p>		Item	0	0.00
D	<p><b>Position of Services, Plant, Equipment, Fittings and Apparatus</b></p> <p>The Contract Drawings give a general indication of the intended layout. The position of the equipment and apparatus, and also the exact routes of the ducts, main and distribution pipework shall be confirmed before installation is commenced. The exact sitting of appliances, pipework, etc., may vary from that indicated.</p> <p>The contractor shall be deemed to have allowed in his Contract Sum for locating terminal points of services (e.g. lighting, switches, socket outlets, lighting points, control switches, thermostats and other initiating devices, taps, stop cocks) in positions plus or minus 1.2m horizontally and vertically from the locations shown on Contract Drawings.</p>		Item		0.00
<b>Total cost carried forward to collection page</b>					<b>0.00</b>

<i>Item</i>	<i>Description</i>	<i>Q'ty</i>	<i>Unit</i>	<i>Rate</i>	<i>Amount (Kshs)</i>
A	<p><b>Setting to Work and Regulating System</b></p> <p>The Contractor shall carry out such tests of the Contract Works as required by British Standard Specifications, or equal and approved codes as specified hereinafter and as customary.</p> <p>No testing or commissioning shall be undertaken except in the presence of and to the satisfaction of the Engineer unless otherwise stated by him (Contractor's own preliminary and proving tests excepted).</p> <p>It will be deemed that the Contractor has included in the Contract Sum for the costs of all fuel, power, water and the like, for testing and commissioning as required as part of the Contract Works. He shall submit for approval to the Engineer a suitable programme for testing and commissioning. The Engineer and Employer shall be given ample warning in writing, as to the date on which testing and commissioning will take place.</p>		Item	0	0.00
B	<p><b>Working Drawings</b></p> <p>The Contractor shall allow for Working Drawings as may be necessary. The Working Drawings shall be complete in such detail not only that the Contract Works can be executed on site but also that the Engineer can approve the Contractor's proposals, detailed designs and intentions in the execution of the Contract Works.</p> <p>Two copies of all Working Drawings shall be submitted to the Engineer for approval. One copy of the Working Drawings submitted to the Engineer for approval shall be returned to the Contractor indicating approval or amendment therein.</p>		Item		0.00
C	<p><b>Record Drawings (As Installed) and Instructions</b></p> <p>The Contractor shall allow for Record Drawings of the installed Contract Works.</p> <p>Three copies of all Record Drawing shall be submitted to the Engineer for approval.</p>		Item		0.00
D	<p><b>Maintenance Manual</b></p> <p>The Contractor shall allow for furnishing the Engineer four copies of a Maintenance Manual relating to the installation forming part of all of the Contract Works.</p> <p>The manual shall be loose-leaf type, International A4 size with stiff covers and cloth bound. It may be in several volumes and shall be subdivided into sections, each section covering one Engineering service system. It shall have a ready means of reference and a detailed index.</p>		Item		0.00
<b>Total cost carried forward to collection page</b>					<b>0.00</b>

<i>Item</i>	<i>Description</i>	<i>Q'ty</i>	<i>Unit</i>	<i>Rate</i>	<i>Amount (Kshs)</i>
	<b>Mobilization and Demobilization</b>				
A	The Contractor shall allow for mobilization of labour plant and equipment to site according to his programme and schedule of work. He shall ensure optimum presence and utilization of labour, plant and equipment. He should not pay and maintain unnecessary labour force or maintain and service idle plant and equipment. Where necessary he shall demobilize and mobilize the labour, plant and equipment, as he deems fit to ensure optimum progress of the works and this shall be considered to be a continuous process as works progress. He shall make provision for this item in his tender. No claim will be entertained where the contractor has not made any provision for mobilization and demobilization of labour, plant and equipment in the preliminary bills of quantities or elsewhere in this tender.		Item	0	0.00
	<b>Contractor Obligation</b>				
B	The contractor will finance all activities as part of his obligation to this contract. The employer shall pay interim payment for materials and work completed on site as his obligation in this contract, as the works progresses. No claims will be entertained for pre- financing of the project by the sub-contractor, or for loss of profit (expectation loss) in case of premature termination, reduction or increase of works as the sub-contractor shall be deemed to have taken adequate measures in programming his works and expenditure and taken necessary financial precaution while executing the works.		Item		0.00
	<b>Validation</b>				
C	Allow for engineers cost in approval of sample sanitary fittings and pumps and casings which cannot be availed on site office.0		Item		0.00
	Allow for profits and attendance for the above %		Item		0.00
	<b>Any other Preliminaries</b>				
D	The contractor to allow for any other preliminaries necessary for hime to complte all the works		Item		
	<b>Total cost carried forward to collection page</b>				<b>0.00</b>
	<b>COLLECTION PAGE</b>				
1	Total cost carried forward				0.00
2	Total cost brought forward from page 5/1				0.00
3	Total cost brought forward from page 5/2				0.00
4	Total cost brought forward from page 5/3				0.00
5	Total cost brought forward from page 5/4				0.00
	<b>Total Cost Carried to Summary Page</b>				<b>0.00</b>

<i>Item</i>	<i>Description</i>	<i>Q'ty</i>	<i>Unit</i>	<i>Rate</i>	<i>Amount (Kshs)</i>
	<p><b>BILL NO.2 (NEW BUILDING)</b></p> <p><b><u>SANITARY FITTINGS</u></b></p> <p><b>(i) ALL ITEMS SHALL BE SUPPLY,DELIVER,INSTALL,TEST AND COMMISSION</b></p> <p><b>(ii) ALL ITEMS SHALL BE COMPLETE WITH ALL ACCESSORIES INCLUDING CONNECTIONS TO THE SERVICES,JOINTING TO WATER SUPPLY OVERFLOWS AND SUPPORTS</b></p> <p><b>(iii) ALL ITEMS SHALL BE COMPLETE WITH ALLPLUGGING AND SCREWING TO WALLS AND FLOORS</b></p> <p><b>(iv) ALL ITEMS SHALL BE AS PER PARTICULAR SPECIFICATIONS</b></p> <p><b>(v) ALL ITEMS SHALL BE SUBJECT TO CLIENT APPROVAL</b></p> <p><b><u>WATER CLOSET AREA</u></b></p> <p><b>Water closet</b></p> <p>A Water Closet A Close-coupled WC suite ('S' or 'P'-trap) in approved colour complete with horizontal outlet to BS 3402 with 7.5 litre valveless low level ceramic cistern and fittings including siphon, 15mm diameter side inlet ball valve, 20mm diameter side overflow, plastic flush bend, dual flush system, inlet connection, chrome-plated lever and heavy plastic seat and cover with metal top fixed (chrome plated) hinges. All to be as IDEAL STANDARD "PLAN"-wc pan model 109.003.34 water closet or equal and</p> <p><b>Toilet Roll Holder</b></p> <p>B Fully recessed toilet roll holder in vitreous china of size 165 x 165mm in approved colour as Ideal Standard Model Cassara Cat No. 109.000.10 or equal and approved.</p> <p><b>Robe Hook</b></p> <p>C Double-ended bathroom robe hook, made of AISI 304 stainless steel black finish <b>AS DALI OR APPROVED EQUIVALENT</b></p>				
	<b>Total carried to collection page</b>				

<i>Item</i>	<i>Description</i>	<i>Q'ty</i>	<i>Unit</i>	<i>Rate</i>	<i>Amount (Kshs)</i>
	<b>WASH HAND AREAS</b>				
	<b>Wash hand basin</b>				
A	Ceramic Rectangular shape Counter top wash hand basin Size: 480x850mm complete with Push waste and bottle trap AS miran OR APPROVED EQUIVALENT	2	No		
	<b>Wash hand basin tap</b>				
B	Self-closing pillar tap DN 15 with Self-closing cartridge, hydraulically controlled, piston-free design, self-closing, stepless adjustment of flow duration AS europlus OR APPROVED EQUIVALENT	2	No		
	<b>Mirror</b>				
C	6mm thick polished plate glass silver backed mirror with bevelled edges, size 610 x 610mm, Plugged and screwed to wall with 4No. chrome plated dome capped screws. The mirror shall rest against a layer of 5mm thick foam AS IMPALA GLASS OR APPROVED EQUIVALENT	2	No		
	<b>Total carried to collection page</b>				
	<b>COLLECTION PAGE</b>				
1	Total cost brought forward from page 5/5				
2	Total cost brought forward from page 5/6				
	<b>Total Cost for Sanitary Fittings</b>				

<i>Item</i>	<i>Description</i>	<i>Q'ty</i>	<i>Unit</i>	<i>Rate</i>	<i>Amount (Kshs)</i>
	<b>BILL NO.3</b>				
	<b>INTERNAL PLUMBING PIPEWORK</b>				
	<b>CPVC Pipework</b>				
A	20mm diameter pipework	2	Lm		
B	25mm diameter pipework	25	Lm		
C	32mm diameter pipework		Lm		
D	40mm diameter pipework		Lm		
E	50mm diameter pipework		Lm		
F	63mm diameter pipework		Lm		
	<b>Bends</b>				
G	20mm diameter bend	2	No.		
H	25mm diameter bend	5	No.		
J	32mm diameter bend		No.		
K	40mm diameter bend		No.		
L	50mm diameter bend		No.		
M	63mm diameter bend		No.		
	<b>Tees</b>				
N	25mm equal tee	8	No.		
P	32mm equal tee	2	No.		
Q	40mm equal tee		No.		
R	50mm equal tee		No.		
S	63mm equal tee		No.		
	<b>Reducing Bushes</b>				
T	25 x 20mm diameter reducer	2	No.		
U	32 x 20mm diameter reducer		No.		
V	32 x 25mm diameter reducer		No.		
W	40 x 25mm diameter reducer		No.		
X	40 x 32mm diameter reducer		No.		
Y	50 x 25mm diameter reducer		No.		
Z	50 x 40mm diameter reducer		No.		
AA	63 x 50mm diameter reducer		No.		
AB	75 x 50mm diameter reducer		No.		
AC	75 x 63mm diameter reducer		No.		
	<b>Male/Female Adapters (CPVC threaded)</b>				
AD	20mm threaded adapter	2	No.		
AE	25mm threaded adapter	8	No.		
AF	32mm threaded adapter		No.		
AG	40mm threaded adapter		No.		
AH	50mm threaded adapter		No.		
	<b>Total Carried to Collection Page</b>				

<b>Item</b>	<b>Description</b>	<b>Q'ty</b>	<b>Unit</b>	<b>Rate</b>	<b>Amount (Kshs)</b>
	<b>Male/Female Bend (CPVC threaded)</b>				
A	20mm threaded bend	3	No.		
B	25mm threaded bend	1	No.		
C	32mm threaded bend		No.		
D	40mm threaded bend		No.		
E	50mm threaded bend		No.		
	<b>Threaded Brass Coupling (CPVC threaded)</b>				
F	25mm threaded coupling	1	No.		
G	32mm threaded coupling	1	No.		
H	40mm threaded coupling		No.		
J	50mm threaded coupling		No.		
K	63mm threaded coupling		No.		
L	75mm threaded coupling		No.		
	<b>Valves</b>				
M	25mm diameter gate valve	2	No.		
N	32mm diameter gate valve	1	No.		
P	40mm diameter gate valve		No.		
Q	50mm diameter gate valve		No.		
R	63mm diameter gate valve		No.		
	<b>Unions</b>				
S	25mm diameter pipe union	2	No.		
T	32mm diameter pipe union	1	No.		
U	40mm diameter pipe union		No.		
V	50mm diameter pipe union		No.		
W	63mm diameter pipe union		No.		
	<b>Pipe Sleeves</b>				
X	100mm diameter heavy duty PVC pipe sleeves for crossing over columns and beams.	2	Lm		
	<b>Pressure Testing</b>				
Y	Allow for all costs for pressure testing for plumbing piping and issuance of pressure testing certificates	1	No.		
	<b>Total Carried Forward</b>				
	<b>COLLECTION PAGE FOR PLUMBING WORKS</b>				
1	Total cost brought forward from page 5/7				
2	Total cost brought forward from page 5/8				
	<b>Total cost for Internal Plumbing Piping</b>				

<i>Item</i>	<i>Description</i>	<i>Q'ty</i>	<i>Unit</i>	<i>Rate</i>	<i>Amount (Kshs)</i>
	<b>BILL NO.4</b>				
	<b>INTERNAL DRAINAGE PIPEWORK</b>				
	<b>FOUL WATER INTERNAL DRAINAGE</b>				
	<b>MuPVC and uPVC Waste and Soil pipework</b>				
A	100mm diameter heavy gauge golden brown UPVC pipe	25	Lm		
B	100mm diameter heavy gauge grey mUPVC pipe	25	Lm		
C	50mm diameter waste pipe	25	Lm		
D	40mm diameter waste pipe	10	Lm		
E	32mm diameter waste pipe	23	Lm		
	<b>Bends</b>				
F	100mm diameter long radius bend	2	No.		
G	100mm diameter short radius bend	2	No.		
H	100mm diameter bend with access	1	No.		
I	100mm diameter sweep bend	1	No.		
J	50mm diameter sweep bend	2	No.		
K	40mm diameter sweep bend	1	No.		
L	32mm diameter sweep bend	2	No.		
	<b>Tees</b>				
M	100mm diameter sweep tee	4	No.		
N	50mm diameter sweep tee	4	No.		
O	40mm diameter sweep tee	1	No.		
P	32mm diameter sweep tee	4	No.		
	<b>Access Caps</b>				
Q	100mm diameter access cap	4	No.		
R	50mm diameter access cap	3	No.		
S	40mm diameter access cap	1	No.		
T	32mm diameter access cap	3	No.		
	<b>Boss Connectors</b>				
U	100 x 50mm diameter boss connector	2	No.		
V	100 x 40mm diameter boss connector	1	No.		
	<b>Single Branches</b>				
W	100mm diameter single branch	1	No.		
	<b>WC Connectors</b>				
X	100mm diameter WC connector	4	No.		
	<b>Total Carried to Collection Page</b>				

<i>Item</i>	<i>Description</i>	<i>Q'ty</i>	<i>Unit</i>	<i>Rate</i>	<i>Amount (Kshs)</i>
	<b>Traps</b>				
A	100 x 50mm diameter floor trap and grating	5	No.		
B	300 x 300mm Gulley trap and heavy duty gulley trap cover	3	No.		
C	600 x 450mm manhole with heavy duty cover. Manual depth to be determined on site but to a minimum of 600mm	2	No.		
D	100mm diameter heavy gauge golden brown UPVC pipe for interconnecting the inspection chambers	25	Lm		
E	Allow for all costs for level testing for drainage piping and issuance of level testing certificates	1	No.		
	<b>Total Carried to Collection Page</b>				
	<b>COLLECTION PAGE FOR FOUL DRAINAGE</b>				
1	Total cost brought forward from page 5/9				
2	Total cost brought forward from page 5/10				
	<b>Total cost for Drainage Pipework</b>				

<i>Item</i>	<i>Description</i>	<i>Q'ty</i>	<i>Unit</i>	<i>Rate</i>	<i>Amount (Kshs)</i>
	<p><b>BILL NO.6</b></p> <p><b>FIRE FIGHTING</b>  <i>Supply, deliver and install the following fire fighting equipment in positions indicated on the contract drawings or as shall be instructed by the Engineer.</i></p> <p><b>Portable Fire Extinguishers</b>  <i>Supply, deliver, install, test and commission the following portable fire extinguishers and conforming to BS EN 3 / BS 1449.</i></p> <p><b>Water/Carbon Dioxide Gas Fire Extinguisher</b></p> <p>A 9 litres water/carbon dioxide gas portable fire extinguisher complete with pressure gauge, initial charge and mounting brackets.</p> <p><b>Carbon Dioxide Gas Fire Extinguisher</b></p> <p>B 5 Kg carbon dioxide gas portable fire extinguisher complete with pressure gauge, initial charge and mounting brackets.</p> <p><b>Dry Chemical Powder Fire Extinguisher</b></p> <p>C 6kg dry chemical powder portable fire extinguisher complete with pressure gauge, initial charge and mounting brackets.</p>				
			No		
			No		
			No		

<i>Item</i>	<i>Description</i>	<i>Q'ty</i>	<i>Unit</i>	<i>Rate</i>	<i>Amount (Kshs)</i>
	<b>Valves</b>				
A	50mm diameter approved medium pressure screw down full way non-rising stem wedge gate valve to BS 5154 PN 20 for series B rating, with wheel and head joints to steel tubing and complete with round male threaded transition fittings. The gate valve to be as PEGLER or approved equivalent.	2	No.		
	<b>Unions</b>				
B	50mm diameter pipe union	2	No.		
	<b>Stand Pipe</b>				
C	15mm diameter bib tap suitable for connecting hose pipe complete with threaded adaptors. The tap to be complete with 5meter long 20mm diameter pipe, bends etc. The chrome plated bib tap to be as Cobra ref.107EC taps or equal and approved.	1	No		
	<b>Pipe Sleeves</b>				
I	75mm diameter heavy duty PVC Class 41 pipe sleeves for crossing over pathways and driveways. The sleeves will be encased in 75mm concrete surround.	6	Lm		
	<b>Sterilization</b>				
D	Allow for flushing out and sterilizing the whole system with chlorine to the satisfaction of the Project Engineer.	1	Item		
	<b>Testing and Commissioning</b>				
E	Allow for pressure testing and commissioning of the plumbing installation to the satisfaction of the Engineer with provision of pressure testing certificates of minimum 5 Bar	1	Item		
	<b>Total carried to collection page</b>				
	<b>COLLECTION PAGE</b>				
1	Total cost brought forward from page 5/13				
	<b>Total Carried Forward to summary Page</b>				

<i>Item</i>	<i>Description</i>	<i>Q'ty</i>	<i>Unit</i>	<i>Rate</i>	<i>Amount (Kshs)</i>
	<b><u>SUMMARY PAGE</u></b>		Page		
1	Total carried forward for sanitary fittings		5/5		
3	Total carried forward for internal plumbing piping		5/6		
4	Total carried forward for drainage piping		5/10		
7	Total carried forward for water reticulation and tanks		5/13		
	<b>Total for Plumbing and Drainage Installation Works carried to final summary page</b>				
	<b><u>FINAL SUMMARY PAGE</u></b>				
<i>Item</i>	<i>Description</i>		<i>Page</i>		<i>Amount (Kshs)</i>
1	Preliminaries		5/4		
2	Total cost for plumbing and drainage installation works		ABOVE		
	<b>Total for Plumbing and Drainage Installation Works carried to grand summary page</b>				

<i>Item</i>	<i>Description</i>	<i>Unit</i>	<i>Amount KSh</i>
	<p><b><u>BILL NO.6 PROVISIONAL SUMS</u></b></p> <p><b><u>LIST OF PROVISIONAL SUMS</u></b></p> <p><i>The following provisional sums are to be measured on completion and priced in accordance with the rates contained in these bills of quantities or prorata thereto or deducted in whole if not required</i></p>		
6.2	Allow a Provisional sum of Kenya Shillings one Hundred and fifty Thousand Only (Ksh. 150,000.00) for documentation, stationery and Supervision expenses for Project Technical Team from State Department for Public Works-Nandi county		
6.3	Allow a Provisional sum of Kenya Shillings fifty Thousand Only (Ksh. 50,000.00) for Supervision expenses for project Management Committee(PMC).		
6.4	Provide a Provisional sum of Kshs Twenty Thousand (20,000.00) for erection of a Signboard, commissioning plaque and branding		
	<p><b>BILL NO. 6</b></p> <p><b>TOTAL PROVISIONAL SUMS CARRIED TO GRAND SUMMARY PAGE</b></p>		

**PROPOSED DIGITAL HUB AT DEPUTY COUNTY COMMISSIONER  
OFFICE-CHESUMEI SUB-COUNTY**

**GRAND SUMMARY**

BILL NO.	DESCRIPTION	PAGE NO.	AMOUNT KSH
1	PARTICULAR PRELIMINARIES	1/6	
2	GENERAL PRELIMINARIES	2/11	
3	ICT HUB	3/20	
4	ELECTRICAL INSTALLATIONS	4/3	
5	MECHANICAL INSTALLATIONS	5/14	
6	PROVISIONAL SUMS	6/1	
	<b>Subtotal</b>		
	Allow for any Discounts		
	<b><u>COST ESTIMATE (VAT Inclusive)</u></b>		

**GS/1**



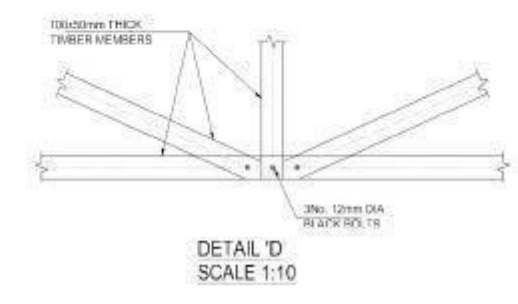
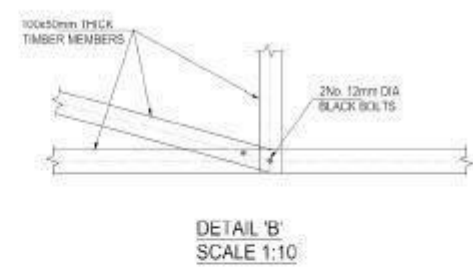
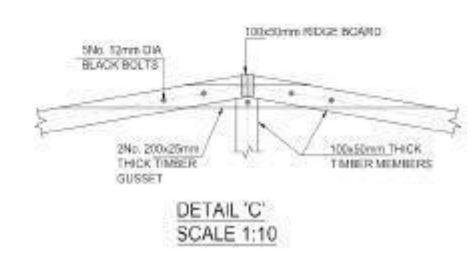
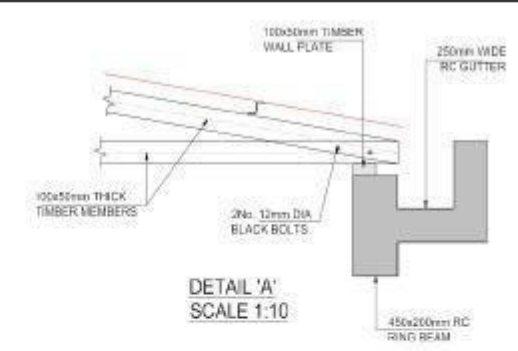
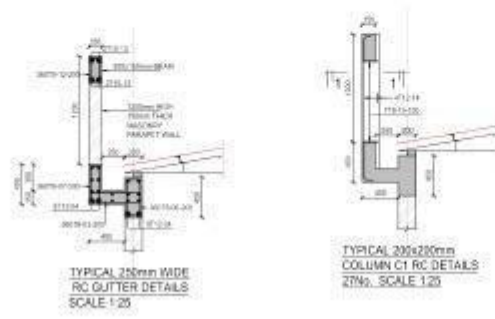
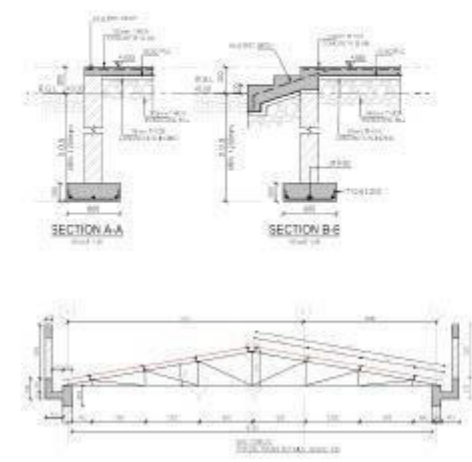
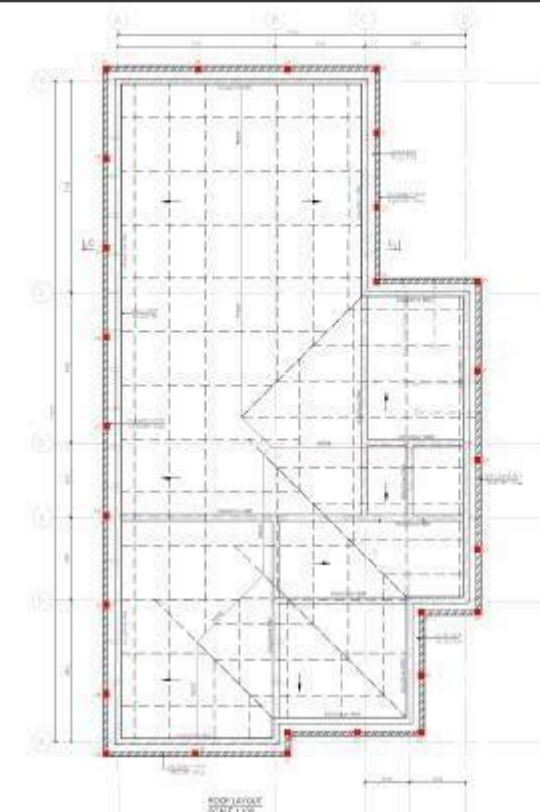
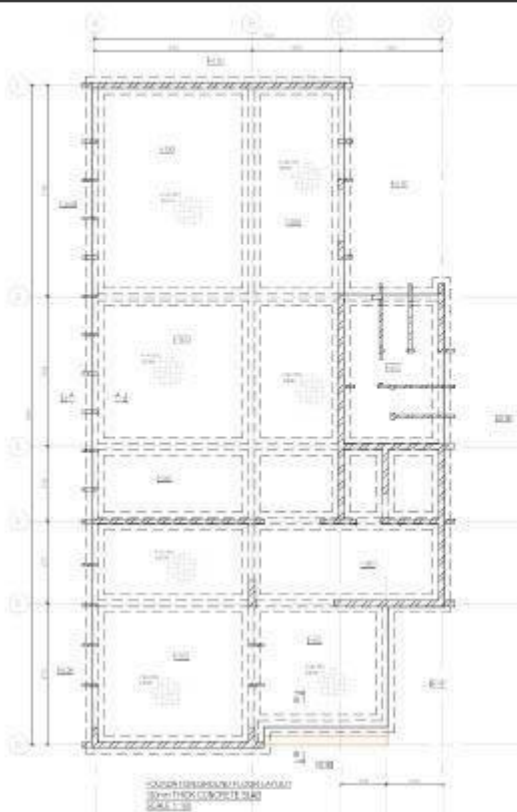

- NOTES**
- All dimensions are to centres unless otherwise stated.
  - All openings to be fixed in compliance with Structural Design and in any instances to be noted to the Engineer.
  - All foundations shall be located as approved plans.
  - The concrete used shall be of grade C30 in accordance with the specifications.
  - All load bearing walls to be 200mm thick masonry/Concrete blocks. Min crushing strength 10 N per 50 kPa.
  - All reinforced concrete walls shall be quality checked and independently checked to the structural engineer's satisfaction.
  - Detail call out for main reinforcement shall be as follows:
    - Foundation - 50mm x
    - Column - 50mm x
    - Beam - 25mm x
    - Slab - 10mm x
  - The reinforcement for structural concrete shall be of Ribbed bars and shall conform to AS/NZS 4673:2001.
  - Structural steel sections shall be as BS 5950.
  - Concrete to fully "Encapsulated Finish" (E.F.) and Painted (see Part 7), before installation of cladding tiles.
  - All structural steel members and connections including welding and bolting, including flow bending and surface to the relevant and latest AS/NZS standards. Bolts shall meet or exceed AS/NZS 1546.
  - Steel drawings must be submitted in good time for approval by the Engineer before assembly of any structure.
  - Using any structure shall be done in accordance with the manufacturer's design and shall be to the Engineer's satisfaction.
  - Unless noted otherwise shall be replaced with approved fix.
  - REDD - Determined On (D)M/1 - "Optimal" basis.
  - IFAD walls to be reinforced with 20mm bars for a minimum distance of every alternate course to engineer's approval.

REVISIONS			
Rev No.	Date	Revised by	Approved by
1	10/01/2024	10/01/2024	10/01/2024

**Proposed**

**PROPOSED JITUME DIGITAL HUB 01**

**Client**

**MINISTRY OF INFORMATION COMMUNICATION AND TECHNOLOGY**

**Project Author**

**Project Structural Engineer**

**STATE DEPARTMENT OF PUBLIC WORKS CHIEF STRUCTURAL ENGINEER**

**By/To**

**JITUME HUB 01 STRUCTURAL DETAILS**

Designed by: J.G.B.	Drawn by: A.B.T.
Checked by: J.G.B.	Approved by: J.G.B.
Issue: 1.00 (1.0)	Date: 10/01/2024
Project No.: JH-01	Page No.: 1