

COUNTY GOVERNMENT OF KILIFI



COUNTY DIVISION OF ENVIRONMENT, FORESTRY, CLIMATE CHANGE AND SOLID WASTE MANAGEMENT

OPEN TENDER ADVERTISEMENT

TENDER NAME;

PROPOSED CONSTRUCTION OF CLIMATE CHANGE INFORMATION
CENTRE DEVELOPMENT OFFICES IN SOKONI WARD – KILIFI
MUNICIPALITY.

INVITATION TO TENDER (ITT) NO:

TENDER NO: KCG/ENVRM/OT/FLOCCA/2225736/2025/2026

CLOSING DATE: 3RD JULY, 2026

COUNTY GOVERNMENT OF KILIFI

PO BOX 519-80108 KILIFI

WEBSITE: www.kilifi.go.ke

TABLE OF CONTENTS

INVITATION TO TENDER	V
APPENDIX TO THE PREFACE.....	vii
GUIDELINES FOR PREPARATION OF TENDER DOCUMENTS	vii
2. PART 1 - TENDERING PROCEDURES	vii
3. PART 2 - PROCUREMENT ENTITY'S REQUIREMENTS	vii
4. PART 3 - CONDITIONS OF CONTRACT AND CONTRACT FORMS	viii
INVITATION TO TENDER.....	X
SECTION I - INSTRUCTIONS TO TENDERERS	1
A. General Provisions	1
1. Scope of Tender	1
2. Fraud and Corruption	1
3. Eligible Tenderers	1
4. Eligible Goods, Equipment, and Services	3
5. Tenderer's Responsibilities	3
B. Contents of Tender Documents	3
6. Sections of Tender Document	3
7. Site visit	4
8. Pre-Tender Meeting.....	4
9. Clarification and amendment of Tender Documents	5
10. Amendment of Tender Documents	5
C. Preparation of Tenders	5
11. Cost of Tendering	5
12. Language of Tender.....	5
13. Documents Comprising the Tender	5
14. Form of Tender and Schedules	6
15. Alternative Tenders	6
16. Tender Prices and Discounts	6
17. Currencies of Tender and Payment	7
18. Documents Comprising the Technical Proposal.....	7
19. Documents Establishing the Eligibility and Qualifications of the Tenderer	
20. Period of Validity of Tenders.....	8
21. Tender Security	8
22. Format and Signing of Tender.....	9
D. Sealing and Marking of Tenders	9
23. Sealing and Marking of Tenders	9
24. Deadline for Submission of Tenders.....	10
25. Late Tenders	10
26. Withdrawal, Substitution, and Modification of Tenders.....	10
27. Tender Opening.....	10
E. Evaluation and Comparison of Tenders	11
28. Confidentiality	11
29. Clarification of Tenders	11
30. Deviations, Reservations, and Omissions.....	12
31. Determination of Responsiveness	12
32. Non-material Non-conformities.....	12
33. Arithmetical Errors.....	12
34. Conversion to Single Currency	13
35. Margin of Preference and Reservations	13
36. Subcontractors	13
37. Evaluation of Tenders.....	13
38. Comparison of Tenders.....	14
39. Abnormally Low Tenders	14

40.	Abnormally High Tenders.....	14
41.	Unbalanced and/or Front-Loaded Tenders	14
42.	Qualifications of the Tenderer	15
43.	Best Evaluated Tender	15
44.	Procuring Entity's Right to Accept Any Tender, and to Reject Any or All Tenders	15
F.	Award of Contract	15
45.	Award Criteria.....	15
46.	Notice of Intention to enter into a Contract	15
47.	Standstill Period	16
48.	Debriefing by the Procuring Entity	16
49.	Letter of Award.....	16
50.	Signing of Contract	16
51.	Appointment of Adjudicator.....	16
52.	Performance Security.....	16
53.	Publication of Procurement Contract.....	17
53.	Procurement Related Complaints	17
	SECTION II-TENDER DATASHEET(TDS)	18
	SECTION III - EVALUATION AND QUALIFY ON CRITERIA.....	23
1.	General Provisions	23
2.	Preliminary examination for Determination of Responsiveness.....	23
3.	Tender Evaluation (ITT 35).....	23
4.	Multiple Contracts.....	23
5.	Alternative Tenders (ITT 13.1).....	24
6.	Margin of Preference is not applicable	24
7.	Post qualification and Contract award (ITT 39), more specifically	24
	SECTION IV – TENDERING FORMS	25
	QUALIFICATION FORMS	28
1.	Form Equ. Equipment.....	28
2.	Form per-1	29
4.	FORM PER-2:.....	30
5.	TENDERERS QUALIFICATION WITHOUT PRE-QUALIFICATION	32
	FORM ELI -1.1.....	32
	FORM ELI -1.2.....	33
	FORM CON – 2.....	34
5.4	FORM FIN – 3.1.....	36
5.5	FORM FIN – 3.2.....	37
5.6	FORM FIN – 3.3.....	38
5.7	FORM FIN – 3.4.....	38
5.8	FORM EXP - 4.1.....	39
5.9	FORM EXP - 4.2(a)	40
5.11	FORM EXP - 4.2(b).....	41
	OTHER FORMS.....	42
6.	FORM OF TENDER.....	42
a)	TENDERER'S ELIGIBILITY- CONFIDENTIAL BUSINESS QUESTIONNAIRE.....	45
b)	CERTIFICATE OF INDEPENDENT TENDER DETERMINATION	48
c)	SELF-DECLARATION FORM - SELF DECLARATION OF THE TENDERER	49
d)	APPENDIX 1- FRAUD AND CORRUPTION	52
7.	FORM OF TENDER SECURITY - DEMAND BANK GUARANTEE.....	54
8.	FORM OF TENDER SECURITY (INSURANCE GUARANTEE)	55

9.	FORM OF TENDER-SECURING DECLARATION	56
10.	APPENDIX TO TENDER	57
	PART II - WORK REQUIREMENTS	58
	SECTION V - DRAWINGS	58
	SECTION VI - SPECIFICATIONS	58
	SECTION VII - BILLS OF QUANTITIES	59
1.	Objectives	59
2.	Day work Schedule	59
3.	Provisional Sums	59
4.	The Bills of Quantities	59
	PART III-CONDITIONS OF CONTRACT AND CONTRACT FORMS	60
	SECTION VIII - GENERAL CONDITIONS OF CONTRACT.....	60
	A. General	
1.	Definitions.....	61
2.	Interpretation	61
3.	Language and Law	62
4.	Project Manager's Decisions.....	63
5.	Delegation	63
6.	Communications.....	63
7.	Subcontracting.....	63
8.	Other Contractors.....	63
9.	Personnel and Equipment	63
10.	Procuring Entity's and Contractor's Risks	63
11.	Procuring Entity's Risks.....	63
12.	Contractor's Risks	64
13.	Insurance.....	64
14.	Site Data.....	64
15.	Contractor to Construct the Works.....	64
16.	The Works to Be Completed by the Intended Completion Date	64
17.	Approval by the Project Manager	64
18.	Safety.....	65
19.	Discoveries	65
20.	Possession of the Site	65
21.	Access to the Site	65
22.	Instructions, Inspections and Audits.....	65
23.	Appointment of the Adjudicator	65
24.	Settlement of Claims and Disputes.....	66
	B. Fraud and Corruption	68
	C. Time Control.....	68
1.	Program.....	68
2.	Extension of the Intended Completion Date	69
3.	Acceleration	69
4.	Delays Ordered by the Project Manager	69
5.	Management Meetings	69
6.	Early Warning	70
	D. Quality Control	69
1.	Identifying Defects	69
2.	Tests.....	69
3.	Correction of Defects.....	69
4.	Uncorrected Defects	69
	E. Cost Control.....	70
1.	Contract Price	70
2.	Changes in the Contract Price	70
3.	Variations	71
4.	Cash Flow Forecasts.....	72

5.	Payment Certificates	72
6.	Payments	72
7.	Compensation Events	73
8.	Tax	73
9.	Currency of Payment	73
10.	Price Adjustment	73
11.	Retention	74
12.	Liquidated Damages	74
13.	Bonus	74
14.	Advance Payment	74
15.	Securities	75
16.	Dayworks	75
17.	Cost of Repairs	75
F.	Finishing the Contract	75
1.	Completion	75
2.	Taking Over	75
3.	Final Account	75
4.	Operating and Maintenance Manuals	75
5.	Termination	76
6.	Payment upon Termination	76
7.	Property	76
8.	Release from Performance	76
SECTION IX - SPECIAL CONDITIONS OF CONTRACT		77
SECTION X - CONTRACT FORMS		88
FORM No. 1 - NOTIFICATION OF INTENTION TO AWARD		80
FORM No. 2 – REQUEST FOR REVIEW		83
FORM No. 3 - LETTER OF AWARD		83
FORM No. 4 - CONTRACT AGREEMENT		84
FORM No. 5 - PERFORMANCE SECURITY [Option 1 - Unconditional Demand Bank Guarantee]		85
FORM No. 6- PERFORMANCE SECURITY [Option 2– Performance Bond]		86
FORM No. 7- ADVANCE PAYMENT SECURITY		88
FORM No. 8- RETENTION MONEY SECURITY		87
FORM No. 9- BENEFICIAL OWNERSHIP DISCLOSURE FORM		87

INVITATION TO TENDER

PROCURING ENTITY– COUNTY DIVISION OF ENVIRONMENT, FORESTRY, CLIMATE CHANGE AND SOLID WASTE MANAGEMENT

TENDER NO. KCG/ENVRM/OT/FLCCA/2225736/2025/2026

CONTRACT DESCRIPTION: PROPOSED CONSTRUCTION OF CLIMATE CHANGE INFORMATION CENTRE DEVELOPMENT OFFICES IN SOKONI WARD – KILIFI MUNICIPALITY.

The County Government of Kilifi invites sealed tenders for the **PROPOSED CONSTRUCTION OF CLIMATE CHANGE INFORMATION CENTRE DEVELOPMENT CENTRE IN SOKONI WARD – KILIFI MUNICIPALITY**

Tendering will be conducted under open competitive method National using a standardized tender document. Tendering is open to all qualified and interested Tenderers.

1. Qualified and interested tenderers may obtain further information and inspect the Tender Documents during office hours *i.e. 0800 to 1700 hours* at the address given below.
2. A complete set of tender documents may be purchased or obtained by interested tenders upon payment of a non-refundable fees of **Ksh 1,000** in cash or Banker's Cheque and payable to the address given below. Tender documents may be obtained electronically from the Website(s) www.kilifi.go.ke or Public Procurement Information Portal. Tender documents obtained electronically will be free of charge.
3. Tender documents may be viewed and downloaded for free from the website www.kilifi.go.ke. Tenderers who download the tender document must forward their particulars immediately to supplychain@kilifi.go.ke to facilitate any further clarification or addendum.
4. Tenders shall be quoted in Kenya Shillings and shall include all taxes. Tenders shall remain valid for **147** days from the date of opening of tenders.
5. All Tenders must be accompanied by a *tender Security of KSH 650,000/= Six hundred and fifty thousand shillings only.*)
6. The Tenderer shall chronologically serialize all pages of the tender documents submitted.
7. Completed tenders must be delivered to the address below on or before **3RD JULY, 2026 at 11:30 Hrs.** Electronic Tenders will *not* be permitted.
8. Tenders will be opened immediately after the deadline date and time specified above or any dead line date and time specified later. Tenders will be publicly opened in the presence of the Tenderers' designated representatives who choose to attend at the address below.
9. Late tenders will be rejected.
10. The addresses referred to above are:
 - A. **Address for obtaining further information and for purchasing tender documents**

County Government of Kilifi
Po. Box 519-80108
Kilifi
supplychain@kilifi.go.ke

11. B. Address for Submission of Tenders.

Ifmis

A. Address for Opening of Tenders.

Electronic

CPA JACINTA TRESA ISMAIL

ACCOUNTING OFFICER- COUNTY DIVISION OF ENVIRONMENT, FORESTRY, CLIMATE CHANGE AND SOLID
WASTE MANAGEMENT

PART 1 - TENDERING PROCEDURES

SECTION I: INSTRUCTIONS TO TENDERERS

A General Provisions

1. Scope of Tender

- 1.1 The Procuring Entity as defined in the Appendix to Conditions of Contract invites tenders for Works Contract as described in the tender documents. The name, identification, and number of lots (contracts) of this Tender Document are **specified in the TDS**.

2. Fraud and Corruption

- 2.1 The Procuring Entity requires compliance with the provisions of the Public Procurement and Asset Disposal Act, 2015, Section 62 “Declaration not to engage in corruption”. The tender submitted by a person shall include a declaration that the person shall not engage in any corrupt or fraudulent practice and a declaration that the person or his or her sub-contractors are not debarred from participating in public procurement proceedings.
- 2.2 The Procuring Entity requires compliance with the provisions of the Competition Act 2010, regarding collusive practices in contracting. Any tenderer found to have engaged in collusive conduct shall be disqualified and criminal and/or civil sanctions may be imposed. To this effect, Tenders shall be required to complete and sign the “Certificate of Independent Tender Determination” annexed to the Form of Tender.
- 2.3 Unfair Competitive Advantage - Fairness and transparency in the tender process require that the firms or their Affiliates competing for a specific assignment do not derive a competitive advantage from having provided consulting services related to this tender. To that end, the Procuring Entity shall indicate in the **Data Sheet** and make available to all the firms together with this tender document all information that would in that respect give such firm any unfair competitive advantage over competing firms.
- 2.4 Unfair Competitive Advantage - Fairness and transparency in the tender process require that the Firms or their Affiliates competing for a specific assignment do not derive a competitive advantage from having provided consulting services related to this tender being tendered for. The Procuring Entity shall indicate in the **TDS** firms (if any) that provided consulting services for the contract being tendered for. The Procuring Entity shall check whether the owners or controllers of the Tenderer are same as those that provided consulting services. The Procuring Entity shall, upon request, make available to any tenderer information that would give such firm unfair competitive advantage over competing firms.

3. Eligible Tenderers

- 3.1 A Tenderer may be a firm that is a private entity, a state-owned enterprise or institution subject to ITT 3.7 or any combination of such entities in the form of a joint venture (JV) under an existing agreement or with the intent to enter into such an agreement supported by a letter of intent. Public employees and their close relatives (*spouses, children, brothers, sisters and uncles and aunts*) are not eligible to participate in the tender. In the case of a joint venture, all members shall be jointly and severally liable for the execution of the entire Contract in accordance with the Contract terms. The JV shall nominate a Representative who shall have the authority to conduct all business for and on behalf of any and all the members of the JV during the tendering process and, in the event the JV is awarded the Contract, during contract execution. The maximum number of JV members shall be specified in the **TDS**.
- 3.2 Public Officers of the Procuring Entity, their Spouses, Child, Parent, Brothers or Sister. Child, Parent, Brother or Sister of a Spouse, their business associates or agents and firms/organizations in which they have a substantial or controlling interest shall not be eligible to tender or be awarded a contract. Public Officers are also not allowed to participate in any procurement proceedings.
- 3.3 A Tenderer shall not have a conflict of interest. Any tenderer found to have a conflict of interest shall be disqualified. A tenderer may be considered to have a conflict of interest for the purpose of this tendering process, if the tenderer:
 - a) Directly or indirectly controls, is controlled by or is under common control with another tenderer; or
 - b) Receives or has received any direct or indirect subsidy from another tenderer; or
 - c) Has the same legal representative as another tenderer; or
 - d) Has a relationship with another tenderer, directly or through common third parties, that puts it in a position to influence the tender of another tenderer, or influence the decisions of the Procuring Entity regarding this

tendering process; or

- e) Any of its affiliates participated as a consultant in the preparation of the design or technical specifications of the works that are the subject of the tender; or
- f) any of its affiliates has been hired (or is proposed to be hired) by the Procuring Entity as Engineer for the Contract implementation; or
- g) Would be providing goods, works, or non-consulting services resulting from or directly related to consulting services for the preparation or implementation of the contract specified in this Tender Document or
- h) Has a close business or family relationship with a professional staff of the Procuring Entity who:
 - i) are directly or indirectly involved in the preparation of the Tender document or specifications of the Contract, and/or the Tender evaluation process of such contract; or
 - ii) would be involved in the implementation or supervision of such Contract unless the conflict stemming from such relationship has been resolved in a manner acceptable to the Procuring Entity throughout the tendering process and execution of the Contract.

3.4 A tenderer shall not be involved in corrupt, coercive, obstructive, collusive or fraudulent practice. A tenderer that is proven to have been involved any of these practices shall be automatically disqualified.

3.5 A Tenderer (either individually or as a JV member) shall not participate in more than one Tender, except for permitted alternative tenders. This includes participation as a subcontractor in other Tenders. Such participation shall result in the disqualification of all Tenders in which the firm is involved. A firm that is not a tenderer or a JV member may participate as a subcontractor in more than one tender. Members of a joint venture may not also make an individual tender, be a subcontractor in a separate tender or be part of another joint venture for the purposes of the same Tender.

3.6 A Tenderer may have the nationality of any country, subject to the restrictions pursuant to ITT 4.8.A Tenderer shall be deemed to have the nationality of a country if the Tenderer is constituted, incorporated or registered in and operates in conformity with the provisions of the laws of that country, as evidenced by its articles of incorporation (or equivalent documents of constitution or association) and its registration documents, as the case may be. This criterion also shall apply to the determination of the nationality of proposed subcontractors or sub-consultants for any part of the Contract including related Services.

3.7 Tenderer that has been debarred from participating in public procurement shall be ineligible to tender or be awarded a contract. The list of debarred firms and individuals is available from the website of PPRA www.ppra.go.ke.

3.8 Tenderers that are state-owned enterprises or institutions may be eligible to compete and be awarded a Contract(s) only if they are accredited by PPRA to be (i) a legal public entity of the state Government and/or public administration, (ii) financially autonomous and not receiving any significant subsidies or budget support from any public entity or Government, and (iii) operating under commercial law and vested with legal rights and liabilities similar to any commercial enterprise to enable it compete with firms in the private sector on an equal basis.

3.9 A Firms and individuals may be ineligible if their countries of origin (a) as a matter of law or official regulations, Kenya prohibits commercial relations with that country, or (b) by an act of compliance with a decision of the United Nations Security Council taken under Chapter VII of the Charter of the United Nations, Kenya prohibits any import of goods or contracting of works or services from that country, or any payments to any country, person, or entity in that country. A tenderer shall provide such documentary evidence of eligibility satisfactory to the Procuring Entity, as the Procuring Entity shall reasonably request.

3.10 Foreign tenderers are required to source at least forty (40%) percent of their contract inputs (in supplies, subcontracts and labor) from national suppliers and contractors. To this end, a foreign tenderer shall provide in its tender documentary evidence that this requirement is met. Foreign tenderers not meeting this criterion will be automatically disqualified. Information required to enable the Procuring Entity determine if this condition is met shall be provided in for this purpose is be provided in “*SECTION III - EVALUATION AND QUALIFICATION CRITERIA, Item 9*”.

3.11 Pursuant to the eligibility requirements of ITT 4.10, a tender is considered a foreign tenderer, if the tenderer is not registered in Kenya or if the tenderer is registered in Kenya and has less than 51 percent ownership by Kenyan

Citizens. JVs are considered as foreign tenderers if the individual member firms are not registered in Kenya or if

are registered in Kenya and have less than 51 percent ownership by Kenyan citizens. The JV shall not subcontract to foreign firms more than 10 percent of the contract price, excluding provisional sums.

3.12 The National Construction Authority Act of Kenya requires that all local and foreign contractors be registered with the National Construction Authority and be issued with a Registration Certificate before they can undertake any construction works in Kenya. Registration shall not be a condition for tender, but it shall be a condition of contract award and signature. A selected tenderer shall be given opportunity to register before such award and signature of contract. Application for registration with National Construction Authority may be accessed from the website www.nca.go.ke.

3.13 The Competition Act of Kenya requires that firms wishing to tender as Joint Venture undertakings which may prevent, distort or lessen competition in provision of services are prohibited unless they are exempt in accordance with the provisions of Section 25 of the Competition Act, 2010. JVs will be required to seek for exemption from the Competition Authority. Exemption shall not be a condition for tender, but it shall be a condition of contract award and signature. A JV tenderer shall be given opportunity to seek such exemption as a condition of award and signature of contract. Application for exemption from the Competition Authority of Kenya may be accessed from the website www.cak.go.ke

3.14 A Kenyan tenderer shall provide evidence of having fulfilled his/her tax obligations by producing a valid tax clearance certificate or tax exemption certificate issued by the Kenya Revenue Authority.

4. Eligible Goods, Equipment, and Services

4.1 Goods, equipment and services to be supplied under the Contract may have their origin in any country that is not eligible under ITT 3.9. At the Procuring Entity's request, Tenderers may be required to provide evidence of the origin of Goods, equipment and services.

4.2 Any goods, works and production processes with characteristics that have been declared by the relevant national environmental protection agency or by other competent authority as harmful to human beings and to the environment shall not be eligible for procurement.

5. Tenderer's Responsibilities

5.1 The tenderer shall bear all costs associated with the preparation and submission of his/her tender, and the Procuring Entity will in no case be responsible or liable for those costs.

5.2 The tenderer, at the tenderer's own responsibility and risk, is encouraged to visit and examine the Site of the Works and its surroundings, and obtain all information that may be necessary for preparing the tender and entering into a contract for construction of the Works. The costs of visiting the Site shall be at the tenderer's own expense.

5.3 The Tenderer and any of its personnel or agents will be granted permission by the Procuring Entity to enter upon its premises and lands for the purpose of such visit. The Tenderer shall indemnify the Procuring Entity against all liability arising from death or personal injury, loss of or damage to property, and any other losses and expenses incurred as a result of the inspection.

5.4 The tenderer shall provide in the Form of Tender and Qualification Information, a preliminary description of the proposed work method and schedule, including charts, as necessary or required.

B. Contents of Tender Documents

6. Sections of Tender Document

6.1 The tender document consists of Parts 1, 2, and 3, which includes all the sections specified below, and which should be read in conjunction with any Addenda issued in accordance with ITT 8.

PART 1 Tendering Procedures

- i) Section I - Instructions to Tenderers (ITT)
- ii) Section II - Tender Data Sheet (TDS)
- iii) Section III - Evaluation and Qualification Criteria
- iv) Section IV - Tendering Forms

PART 2 Works Requirements

- i) Section V - Drawings
- ii) Section VI - Specifications
- iii) Section VII - Bills of Quantities

PART 3 Conditions of Contract and Contract Forms

- i) Section VIII - General Conditions of Contract (GCC)
- ii) Section IX - Special Conditions of Contract (SC)
- iii) Section X - Contract Forms

6.2 The Invitation to Tender Document (ITT) issued by the Procuring Entity is not part of the Contract documents.

6.3 Unless obtained directly from the Procuring Entity, the Procuring Entity is not responsible for the completeness of the Tender document, responses to requests for clarification, the minutes of the pre-Tender meeting (if any), or Addenda to the Tender document in accordance with ITT 8. In case of any contradiction, documents obtained directly from the Procuring Entity shall prevail.

The Tenderer is expected to examine all instructions, forms, terms, and specifications in the Tender Document and to furnish with its Tender all information and documentation as is required by the Tender document.

7. Site Visit

7.1 The Tenderer, at the Tenderer's own responsibility and risk, is encouraged to visit and examine and inspect the Site of the Required Services and its surroundings and obtain all information that may be necessary for preparing the Tender and entering into a contract for the Services. The costs of visiting the Site shall be the Tenderer's own expense.

8. Pre-Tender Meeting

8.1 The Procuring Entity shall specify in the **TDS** if a pre-tender meeting will be held, when and where. The Procuring Entity shall also specify in the **TDS** if a pre-arranged pretender site visit will be held and when. The Tenderer's designated representative is invited to attend a pre-arranged pretender visit of the site of the works. The purpose of the meeting will be to clarify issues and to answer questions on any matter that may be raised at that stage.

8.2 The Tenderer is requested to submit any questions in writing, to reach the Procuring Entity not later than the period specified in the **TDS** before the meeting.

8.3 Minutes of the pre-Tender meeting and the pre-arranged pretender site visit of the site of the works, if applicable, including the text of the questions asked by Tenderers and the responses given, together with any responses prepared after the meeting, will be transmitted promptly to all Tenderers who have acquired the Tender Documents in accordance with ITT 6.3. Minutes shall not identify the source of the questions asked.

8.4 The Procuring Entity shall also promptly publish anonymized (*no names*) Minutes of the pre-Tender meeting and the pre-arranged pretender visit of the site of the works at the web page identified in the **TDS**. Any modification to the Tender Documents that may become necessary as a result of the pre-tender meeting and the pre-arranged pretender site visit, shall be made by the Procuring Entity exclusively through the issue of an Addendum pursuant to ITT 8 and not through the minutes of the pre-Tender meeting. Nonattendance at the pre-Tender meeting will not be a cause for disqualification of a Tenderer.

9. Clarification and amendments of Tender Documents

9.1 A Tenderer requiring any clarification of the Tender Document shall contact the Procuring Entity in writing at the Procuring Entity's address specified in the **TDS** or raise its enquiries during the pre-Tender meeting and the pre-

arranged pretender visit of the site of the works if provided for in accordance with ITT 8.4. The Procuring Entity will respond in writing to any request for clarification, provided that such request is received no later than the period specified in the **TDS** prior to the deadline for submission of tenders. The Procuring Entity shall forward copies of its response to all tenderers who have acquired the Tender Documents in accordance with ITT 6.3, including a description of the inquiry but without identifying its source. If specified in the **TDS**, the Procuring Entity shall also promptly publish its response at the web page identified in the **TDS**. Should the clarification result in changes to the essential elements of the Tender Documents, the Procuring Entity shall amend the Tender Documents appropriately following the procedure under ITT 8.4.

10. Amendment of Tendering Document

- 10.1 At any time prior to the deadline for submission of Tenders, the Procuring Entity may amend the Tendering document by issuing addenda.
- 10.2 Any addendum issued shall be part of the tendering document and shall be communicated in writing to all who have obtained the tendering document from the Procuring Entity in accordance with ITT 6.3. The Procuring Entity shall also promptly publish the addendum on the Procuring Entity's web page in accordance with ITT 8.4.
- 10.3 To give prospective Tenderers reasonable time in which to take an addendum into account in preparing their Tenders, the Procuring Entity shall extend, as necessary, the deadline for submission of Tenders, in accordance with ITT 25.2 below.

C. Preparation of Tenders

11. Cost of Tendering

- 11.1 The Tenderer shall bear all costs associated with the preparation and submission of its Tender, and the Procuring Entity shall not be responsible or liable for those costs, regardless of the conduct or outcome of the tendering process.

12. Language of Tender

- 12.1 The Tender, as well as all correspondence and documents relating to the tender exchanged by the tenderer and the Procuring Entity, shall be written in the English Language. Supporting documents and printed literature that are part of the Tender may be in another language provided they are accompanied by an accurate and notarized translation of the relevant passages into the English Language, in which case, for purposes of interpretation of the Tender, such translation shall govern.

13. Documents Comprising the Tender

- 13.1 The Tender shall comprise the following:
- a) Form of Tender prepared in accordance with ITT 14;
 - b) Schedules including priced Bill of Quantities, completed in accordance with ITT 14 and ITT 16;
 - c) Tender Security or Tender-Securing Declaration, in accordance with ITT 21.1;
 - d) Alternative Tender, if permissible, in accordance with ITT 15;
 - e) Authorization: written confirmation authorizing the signatory of the Tender to commit the Tenderer, in accordance with ITT 22.3;
 - f) Qualifications: documentary evidence in accordance with ITT 19 establishing the Tenderer's qualifications to perform the Contract if its Tender is accepted;
 - g) Conformity: a technical proposal in accordance with ITT 18;
 - h) Any other document required in the **TDS**.
- 13.2 In addition to the requirements under ITT 11.1, Tenders submitted by a JV shall include a copy of the Joint Venture Agreement entered into by all members. Alternatively, a letter of intent to execute a Joint Venture Agreement in the event of a successful Tender shall be signed by all members and submitted with the Tender,

together with a copy of the proposed Agreement. The Tenderer shall chronologically serialize pages of all tender documents submitted.

13.3 The Tenderer shall furnish in the Form of Tender information on commissions and gratuities, if any, paid or to be paid to agents or any other party relating to this Tender.

14. Form of Tender and Schedules

14.1 The Form of Tender and Schedules, including the Bill of Quantities, shall be prepared using the relevant forms furnished in Section IV, Tendering Forms. The forms must be completed without any alterations to the text, and no substitutes shall be accepted except as provided under ITT 20.3. All blank spaces shall be filled in with the information requested.

15. Alternative Tenders

15.1 Unless otherwise specified in the **TDS**, alternative Tenders shall not be considered.

15.2 When alternative times for completion are explicitly invited, a statement to that effect will be included in the **TDS**, and the method of evaluating different alternative times for completion will be described in Section III, Evaluation and Qualification Criteria.

15.3 Except as provided under ITT 13.4 below, Tenderers wishing to offer technical alternatives to the requirements of the Tender Documents must first price the Procuring Entity's design as described in the Tender Documents and shall further provide all information necessary for a complete evaluation of the alternative by the Procuring Entity, including drawings, design calculations, technical specifications, breakdown of prices, and proposed construction methodology and other relevant details. Only the technical alternatives, if any, of the Tenderer with the Winning Tender conforming to the basic technical requirements shall be considered by the Procuring Entity. When specified in the **TDS**, Tenderers are permitted to submit alternative technical solutions for specified parts of the Works, and such parts will be identified in the **TDS**, as will the method for their evaluating, and described in Section VII, Works' Requirements.

16. Tender Prices and Discounts

16.1 The prices and discounts (including any price reduction) quoted by the Tenderer in the Form of Tender and in the Bill of Quantities shall conform to the requirements specified below.

16.2 The Tenderer shall fill in rates and prices for all items of the Works described in the Bill of Quantities. Items against which no rate or price is entered by the Tenderer shall be deemed covered by the rates for other items in the Bill of Quantities and will not be paid for separately by the Procuring Entity. An item not listed in the priced Bill of Quantities shall be assumed to be not included in the Tender, and provided that the Tender is determined substantially responsive notwithstanding this omission, the average price of the item quoted by substantially responsive Tenderers will be added to the Tender price and the equivalent total cost of the Tender so determined will be used for price comparison.

16.3 The price to be quoted in the Form of Tender, in accordance with ITT 14.1, shall be the total price of the Tender, including any discounts offered.

16.4 The Tenderer shall quote any discounts and the methodology for their application in the Form of Tender, in accordance with ITT 14.1.

16.5 It will be specified in the **TDS** if the rates and prices quoted by the Tenderer are or are not subject to adjustment during the performance of the Contract in accordance with the provisions of the Conditions of Contract, except in cases where the contract is subject to fluctuations and adjustments, not fixed price. In such a case, the Tenderer shall furnish the indices and weightings for the price adjustment formulae in the Schedule of Adjustment Data and the Procuring Entity may require the Tenderer to justify its proposed indices and weightings.

16.6 Where tenders are being invited for individual lots (contracts) or for any combination of lots (packages), tenderers wishing to offer discounts for the award of more than one Contract shall specify in their Tender the price reductions applicable to each package, or alternatively, to individual Contracts within the package. Discounts shall be submitted in accordance with ITT 16.4, provided the Tenders for all lots (contracts) are opened at the same time.

16.7 All duties, taxes, and other levies payable by the Contractor under the Contract, or for any other cause, as of the date 30 days prior to the deadline for submission of Tenders, shall be included in the rates and prices and the total Tender Price submitted by the Tenderer.

17. Currencies of Tender and Payment

17.1 Tenderers shall quote entirely in Kenya Shillings. The unit rates and the prices shall be quoted by the Tenderer in the Bill of Quantities, entirely in Kenya shillings. A Tenderer expecting to incur expenditures in other currencies for inputs to the Works supplied from outside Kenya shall devise own ways of getting foreign currency to meet those expenditures.

18. Documents Comprising the Technical Proposal

18.1 The Tenderer shall furnish a technical proposal including a statement of work methods, equipment, personnel, schedule and any other information as stipulated in Section IV, Tender Forms, in sufficient detail to demonstrate the adequacy of the Tenderer's proposal to meet the work's requirements and the completion time.

19. Documents Establishing the Eligibility and Qualifications of the Tenderer

19.1 Tenderers shall complete the Form of Tender, included in Section IV, Tender Forms, to establish Tenderer's eligibility in accordance with ITT 4.

19.2 In accordance with Section III, Evaluation and Qualification Criteria, to establish its qualifications to perform the Contract the Tenderer shall provide the information requested in the corresponding information sheets included in Section IV, Tender Forms.

19.3 A margin of preference will not be allowed. Preference and reservations will be allowed, individually or in joint ventures. Applying for eligibility for Preference and reservations shall supply all information required to satisfy the criteria for eligibility specified in accordance with ITT 33.1.

19.4 Tenderers shall be asked to provide, as part of the data for qualification, such information, including details of ownership, as shall be required to determine whether, according to the classification established by the Procuring Entity, a contractor or group of contractors qualifies for a margin of preference. Further the information will enable the Procuring Entity identify any actual or potential conflict of interest in relation to the procurement and/or contract management processes, or a possibility of collusion between tenderers, and thereby help to prevent any corrupt influence in relation to the procurement process or contract management.

19.5 The purpose of the information described in ITT 19.4 above overrides any claims to confidentiality which a tenderer may have. There can be no circumstances in which it would be justified for a tenderer to keep information relating to its ownership and control confidential where it is tendering to undertake public sector work and receive public sector funds. Thus, confidentiality will not be accepted by the Procuring Entity as a justification for a Tenderer's failure to disclose, or failure to provide required information on its ownership and control.

19.6 The Tenderer shall provide further documentary proof, information or authorizations that the Procuring Entity may request in relation to ownership and control which information on any changes to the information which was provided by the tenderer under ITT 6.3. The obligations to require this information shall continue for the duration of the procurement process and contract performance and after completion of the contract, if any change to the information previously provided may reveal a conflict of interest in relation to the award or management of the contract.

19.7 All information provided by the tenderer pursuant to these requirements must be complete, current and accurate as at the date of provision to the Procuring Entity. In submitting the information required pursuant to these requirements, the Tenderer shall warrant that the information submitted is complete, current and accurate as at the date of submission to the Procuring Entity.

19.8 If a tenderer fails to submit the information required by these requirements, its tender will be rejected. Similarly, if the Procuring Entity is unable, after taking reasonable steps, to verify to a reasonable degree the information submitted by a tenderer pursuant to these requirements, then the tender will be rejected.

19.9 If information submitted by a tenderer pursuant to these requirements, or obtained by the Procuring Entity (whether through its own enquiries, through notification by the public or otherwise), shows any conflict of

interest which could materially and improperly benefit the tenderer in relation to the procurement or contract management process, then:

- i) if the procurement process is still ongoing, the tenderer will be disqualified from the procurement process,
- ii) if the contract has been awarded to that tenderer, the contract award will be set aside,
- iii) the tenderer will be referred to the relevant law enforcement authorities for investigation of whether the tenderer or any other persons have committed any criminal offence.

19.10 If a tenderer submits information pursuant to these requirements that is incomplete, inaccurate or out-of-date, or attempts to obstruct the verification process, then the consequences ITT 6.7 will ensue unless the tenderer can show to the reasonable satisfaction of the Procuring Entity that any such act was not material, or was due to genuine error which was not attributable to the intentional act, negligence or recklessness of the tenderer.

20. Period of Validity of Tenders

20.1 Tenders shall remain valid for the Tender Validity period specified in the **TDS**. The Tender Validity period starts from the date fixed for the Tender submission deadline (as prescribed by the Procuring Entity in accordance with ITT 24). A Tender valid for a shorter period shall be rejected by the Procuring Entity as non-responsive.

20.2 In exceptional circumstances, prior to the expiration of the Tender validity period, the Procuring Entity may request Tenderers to extend the period of validity of their Tenders. The request and the responses shall be made in writing. If a Tender Security is requested in accordance with ITT 21.1, it shall also be extended for thirty (30) days beyond the deadline of the extended validity period. A Tenderer may refuse the request without forfeiting its Tender security. A Tenderer granting the request shall not be required or permitted to modify its Tender, except as provided in ITT 20.3.

20.3 If the award is delayed by a period exceeding the number of days to be specified in the **TDS** days beyond the expiry of the initial tender validity period, the Contract price shall be determined as follows:

- a) in the case of **fixed price** contracts, the Contract price shall be the tender price adjusted by the factor specified in the **TDS**;
- b) in the case of **adjustable price** contracts, no adjustment shall be made; or in any case, tender evaluation shall be based on the tender price without taking into consideration the applicable correction from those indicated above.

21. Tender Security

21.1 The Tenderer shall furnish as part of its Tender, either a Tender-Securing Declaration or a Tender Security as specified in the **TDS**, in original form and, in the case of a Tender Security, in the amount and currency specified in the **TDS**. A Tender-Securing Declaration shall use the form included in Section IV, Tender Forms.

21.2 If a Tender Security is specified pursuant to ITT 19.1, the Tender Security shall be a demand guarantee in any of the following forms at the Tenderer's option:

- a) an unconditional Bank Guarantee issued by reputable commercial bank); or
- b) an irrevocable letter of credit;
- c) a Banker's cheque issued by a reputable commercial bank; or
- d) another security specified **in the TDS**,

21.3 If an unconditional bank guarantee is issued by a bank located outside Kenya, the issuing bank shall have a correspondent bank located in Kenya to make it enforceable. The Tender Security shall be valid for thirty (30) days beyond the original validity period of the Tender, or beyond any period of extension if requested under ITT 20.2.

21.4 If a Tender Security or Tender-Securing Declaration is specified pursuant to ITT 19.1, any Tender not accompanied by a substantially responsive Tender Security or Tender-Securing Declaration shall be rejected by the Procuring Entity as non-responsive.

21.5 If a Tender Security is specified pursuant to ITT 21.1, the Tender Security of unsuccessful Tenderers shall be returned as promptly as possible upon the successful Tenderer's signing the Contract and furnishing the Performance Security and any other documents required in the **TDS**. The Procuring Entity shall also promptly return the tender security to the tenderers where the procurement proceedings are terminated, all tenders were determined nonresponsive or a bidder declines to extend tender validity period.

21.6 The Tender Security of the successful Tenderer shall be returned as promptly as possible once the successful Tenderer has signed the Contract and furnished the required Performance Security, and any other documents required in the **TDS**.

21.7 The Tender Security may be forfeited or the Tender-Securing Declaration executed:

- e) if a Tenderer withdraws its Tender during the period of Tender validity specified by the Tenderer on the Form of Tender, or any extension thereto provided by the Tenderer; or
- f) if the successful Tenderer fails to:
 - i) sign the Contract in accordance with ITT 50; or
 - ii) furnish a Performance Security and if required in the **TDS**, and any other documents required in the **TDS**.

21.8 Where tender securing declaration is executed, the Procuring Entity shall recommend to the PPRA that PPRA debars the Tenderer from participating in public procurement as provided in the law.

21.9 The Tender Security or the Tender-Securing Declaration of a JV shall be in the name of the JV that submits the Tender. If the JV has not been legally constituted into a legally enforceable JV at the time of tendering, the Tender Security or the Tender-Securing Declaration shall be in the names of all future members as named in the letter of intent referred to in ITT 4.1 and ITT 11.2.

21.10 A tenderer shall not issue a tender security to guarantee itself.

22. Format and Signing of Tender

22.1 The Tenderer shall prepare one original of the documents comprising the Tender as described in ITT 13 and clearly mark it "ORIGINAL." Alternative Tenders, if permitted in accordance with ITT 15, shall be clearly marked "ALTERNATIVE." In addition, the Tenderer shall submit copies of the Tender, in the number specified in the **TDS** and clearly mark them "COPY." In the event of any discrepancy between the original and the copies, the original shall prevail.

22.2 Tenderers shall mark as "CONFIDENTIAL" all information in their Tenders which is confidential to their business. This may include proprietary information, trade secrets, or commercial or financially sensitive information.

22.3 The original and all copies of the Tender shall be typed or written in indelible ink and shall be signed by a person duly authorized to sign on behalf of the Tenderer. This authorization shall consist of a written confirmation as specified in the **TDS** and shall be attached to the Tender. The name and position held by each person signing the authorization must be typed or printed below the signature. All pages of the Tender where entries or amendments have been made shall be signed or initialed by the person signing the Tender.

22.4 In case the Tenderer is a JV, the Tender shall be signed by an authorized representative of the JV on behalf of the JV, and to be legally binding on all the members as evidenced by a power of attorney signed by their legally authorized representatives.

22.5 Any inter-lineation, erasures, or overwriting shall be valid only if they are signed or initialed by the person signing the Tender.

D. Submission and Opening of Tenders

23. Sealing and Marking of Tenders

23.1 Depending on the sizes or quantities or weight of the tender documents, a tenderer may use an envelope, package or container. The Tenderer shall deliver the Tender in a single sealed envelope, or in a single sealed package, or in a single sealed container bearing the name and Reference number of the Tender, addressed to the Procuring Entity and a warning not to open before the time and date for Tender opening date. Within the single envelope, package or container, the Tenderer shall place the following separate, sealed envelopes:

- a) in an envelope or package or container marked "ORIGINAL", all documents comprising the Tender, as described in ITT 11; and
- b) in an envelope or package or container marked "COPIES", all required copies of the Tender; and
- c) if alternative Tenders are permitted in accordance with ITT 15, and if relevant:

- i) in an envelope or package or container marked “ORIGINAL –ALTERNATIVE TENDER”, the alternative Tender; and
- ii) in the envelope or package or container marked “COPIES- ALTERNATIVE TENDER”, all required copies of the alternative Tender.

The inner envelopes or packages or containers shall:

- a) bear the name and address of the Procuring Entity.
- b) bear the name and address of the Tenderer; and
- c) bear the name and Reference number of the Tender.

23.2 If an envelope or package or container is not sealed and marked as required, the *Procuring Entity* will assume no responsibility for the misplacement or premature opening of the Tender. Tenders that are misplaced or opened prematurely will not be accepted.

24. Deadline for Submission of Tenders

24.1 Tenders must be received by the Procuring Entity at the address specified in the **TDS** and no later than the date and time also specified in the **TDS**. When so specified in the **TDS**, Tenderers shall have the option of submitting their Tenders electronically. Tenderers submitting Tenders electronically shall follow the electronic Tender submission procedures specified in the **TDS**.

24.2 The Procuring Entity may, at its discretion, extend the deadline for the submission of Tenders by amending the Tender Documents in accordance with ITT 8, in which case all rights and obligations of the Procuring Entity and Tenderers previously subject to the deadlines shall thereafter be subject to the deadlines as extended.

25. Late Tenders

25.1 The Procuring Entity shall not consider any Tender that arrives after the deadline for submission of tenders, in accordance with ITT 24. Any Tender received by the Procuring Entity after the deadline for submission of Tenders shall be declared late, rejected, and returned unopened to the Tenderer.

26. Withdrawal, Substitution, and Modification of Tenders

26.1 A Tenderer may withdraw, substitute, or modify its Tender after it has been submitted by sending a written notice, duly signed by an authorized representative, and shall include a copy of the authorization in accordance with ITT 22.3, (except that withdrawal notices do not require copies). The corresponding substitution or modification of the Tender must accompany the respective written notice. All notices must be:

- a) prepared and submitted in accordance with ITT 22 and ITT 23 (except that withdrawal notices do not require copies), and in addition, the respective envelopes shall be clearly marked “WITHDRAWAL,” “SUBSTITUTION,” “MODIFICATION;” and
- b) received by the Procuring Entity prior to the deadline prescribed for submission of Tenders, in accordance with ITT 24.

26.2 Tenders requested to be withdrawn in accordance with ITT 26.1 shall be returned unopened to the Tenderers.

26.3 No Tender may be withdrawn, substituted, or modified in the interval between the deadline for submission of Tenders and the expiration of the period of Tender validity specified by the Tenderer on the Form of Tender or any extension thereof.

27. Tender Opening

27.1 Except in the cases specified in ITT 23 and ITT 26.2, the Procuring Entity shall publicly open and read out all Tenders received by the deadline, at the date, time and place specified in the **TDS**, in the presence of Tenderers' designated representatives who chooses to attend. Any specific electronic Tender opening procedures required if electronic Tendering is permitted in accordance with ITT 24.1, shall be as specified in the **TDS**.

27.2 First, envelopes marked “WITHDRAWAL” shall be opened and read out and the envelopes with the corresponding Tender shall not be opened, but returned to the Tenderer. No Tender withdrawal shall be permitted unless the corresponding withdrawal notice contains a valid authorization to request the withdrawal and is read out at Tender opening.

- 27.3 Next, envelopes marked "SUBSTITUTION" shall be opened and read out and exchanged with the corresponding Tender being substituted, and the substituted Tender shall not be opened, but returned to the Tenderer. No Tender substitution shall be permitted unless the corresponding substitution notice contains a valid authorization to request the substitution and is read out at Tender opening.
- 27.4 Next, envelopes marked "MODIFICATION" shall be opened and read out with the corresponding Tender. No Tender modification shall be permitted unless the corresponding modification notice contains a valid authorization to request the modification and is read out at Tender opening.
- 27.5 Next, all remaining envelopes shall be opened one at a time, reading out: the name of the Tenderer and whether there is a modification; the total Tender Price, per lot (contract) if applicable, including any discounts and alternative Tenders; the presence or absence of a Tender Security or Tender-Securing Declaration, if required; and any other details as the Procuring Entity may consider appropriate.
- 27.6 Only Tenders, alternative Tenders and discounts that are opened and read out at Tender opening shall be considered further for evaluation. The Form of Tender and pages of the Bills of Quantities are to be initialed by the members of the tender opening committee attending the opening. The number of representatives of the Procuring Entity to sign shall be specified in the **TDS**.
- 27.7 At the Tender Opening, the Procuring Entity shall neither discuss the merits of any Tender nor reject any Tender (except for late Tenders, in accordance with ITT 25.1).
- 27.8 The Procuring Entity shall prepare minutes of the Tender Opening that shall include, as a minimum:
- a) the name of the Tenderer and whether there is a withdrawal, substitution, or modification;
 - b) the Tender Price, per lot (contract) if applicable, including any discounts;
 - c) any alternative Tenders;
 - d) the presence or absence of a Tender Security, if one was required.
 - e) number of pages of each tender document submitted.
- 27.9 The Tenderers' representatives who are present shall be requested to sign the minutes. The omission of a Tenderer's signature on the minutes shall not invalidate the contents and effect of the minutes. A copy of the tender opening register shall be distributed to all Tenderers upon request.

E. Evaluation and Comparison of Tenders

28. Confidentiality

- 28.1 Information relating to the evaluation of Tenders and recommendation of contract award shall not be disclosed to Tenderers or any other persons not officially concerned with the Tender process until information on Intention to Award the Contract is transmitted to all Tenderers in accordance with ITT 46.
- 28.2 Any effort by a Tenderer to influence the Procuring Entity in the evaluation of the Tenders or Contract award decisions may result in the rejection of its tender.
- 28.3 Notwithstanding ITT 28.2, from the time of tender opening to the time of contract award, if a tenderer wishes to contact the Procuring Entity on any matter related to the tendering process, it shall do so in writing.

29. Clarification of Tenders

- 29.1 To assist in the examination, evaluation, and comparison of the tenders, and qualification of the tenderers, the Procuring Entity may, at its discretion, ask any tenderer for a clarification of its tender, given a reasonable time for a response. Any clarification submitted by a tenderer that is not in response to a request by the Procuring Entity shall not be considered. The Procuring Entity's request for clarification and the response shall be in writing. No change, including any voluntary increase or decrease, in the prices or substance of the tender shall be sought, offered, or permitted, except to confirm the correction of arithmetic errors discovered by the Procuring Entity in the evaluation of the tenders, in accordance with ITT 33.
- 29.2 If a tenderer does not provide clarifications of its tender by the date and time set in the Procuring Entity's request for clarification, its Tender may be rejected.

30. Deviations, Reservations, and Omissions

30.1 During the evaluation of tenders, the following definitions apply:

- a) "Deviation" is a departure from the requirements specified in the tender document;
- b) "Reservation" is the setting of limiting conditions or withholding from complete acceptance of the requirements specified in the tender document; and
- c) "Omission" is the failure to submit part or all of the information or documentation required in the Tender document.

31. Determination of Responsiveness

31.1 The Procuring Entity's determination of a Tender's responsiveness is to be based on the contents of the tender itself, as defined in ITT 13.

31.2 A substantially responsive Tender is one that meets the requirements of the Tender document without material deviation, reservation, or omission. A material deviation, reservation, or omission is one that, if accepted, would:

- a) affect in any substantial way the scope, quality, or performance of the Works specified in the Contract; or
- b) limit in any substantial way, inconsistent with the tender document, the Procuring Entity's rights or the tenderer's obligations under the proposed contract; or
- c) if rectified, would unfairly affect the competitive position of other tenderers presenting substantially responsive tenders.

31.3 The Procuring Entity shall examine the technical aspects of the tender submitted in accordance with ITT 18, to confirm that all requirements of Section VII, Works' Requirements have been met without any material deviation, reservation or omission.

31.4 If a tender is not substantially responsive to the requirements of the tender document, it shall be rejected by the Procuring Entity and may not subsequently be made responsive by correction of the material deviation, reservation, or omission.

32. Non-material Non-conformities

32.1 Provided that a tender is substantially responsive, the Procuring Entity may waive any non-conformities in the tender.

32.2 Provided that a Tender is substantially responsive, the Procuring Entity may request that the tenderer submit the necessary information or documentation, within a reasonable period, to rectify non-material non-conformities in the tender related to documentation requirements. Requesting information or documentation on such non-conformities shall not be related to any aspect of the price of the tender. Failure of the tenderer to comply with the request may result in the rejection of its tender.

32.3 Provided that a tender is substantially responsive, the Procuring Entity shall rectify quantifiable non-material non-conformities related to the Tender Price. To this effect, the Tender Price shall be adjusted, for comparison purposes only, to reflect the price of a missing or non-conforming item or component in the manner specified in the TDS.

33. Arithmetical Errors

33.1 The tender sum as submitted and read out during the tender opening shall be absolute and final and shall not be the subject of correction, adjustment or amendment in any way by any person or entity.

33.2 Provided that the Tender is substantially responsive, the Procuring Entity shall handle errors on the following basis:

- a) Any error detected if considered a major deviation that affects the substance of the tender, shall lead to disqualification of the tender as non-responsive.
- b) Any errors in the submitted tender arising from a miscalculation of unit price, quantity, and subtotal and total bid price shall be considered as a major deviation that affects the substance of the tender and shall lead to disqualification of the tender as non-responsive. and
- c) if there is a discrepancy between words and figures, the amount in words shall prevail

33.3 Tenderers shall be notified of any error detected in their bid during the notification of a ward.

34. Currency provisions

34.1 Tenders will be priced in Kenya Shillings only. Tenderers quoting in currencies other than in Kenya shillings will be determined non-responsive and rejected.

35. Margin of Preference and Reservations

35.1 No margin of preference shall be allowed on contracts for small works.

35.2 Where it is intended to reserve the contract to specific groups under Small and Medium Enterprises, or enterprise of women, youth and/or persons living with disability, who are appropriately registered as such by the authority to be specified in the **TDS**, a procuring entity shall ensure that the invitation to tender specifically indicates that only businesses/firms belonging to those specified groups are the only ones eligible to tender. Otherwise if no so stated, the invitation will be open to all tenderers.

36. Nominated Subcontractors

36.1 Unless otherwise stated in the **TDS**, the Procuring Entity does not intend to execute any specific elements of the Works by subcontractors selected in advance by the Procuring Entity.

36.2 Tenderers may propose subcontracting up to the percentage of total value of contracts or the volume of works as specified in the **TDS**. Subcontractors proposed by the Tenderer shall be fully qualified for their parts of the Works.

36.3 The subcontractor's qualifications shall not be used by the Tenderer to qualify for the Works unless their specialized parts of the Works were previously designated by the Procuring Entity in the **TDS** as can be met by subcontractors referred to hereafter as 'Specialized Subcontractors', in which case, the qualifications of the Specialized Subcontractors proposed by the Tenderer may be added to the qualifications of the Tenderer.

37. Evaluation of Tenders

37.1 The Procuring Entity shall use the criteria and methodologies listed in this ITT and Section III, Evaluation and Qualification Criteria. No other evaluation criteria or methodologies shall be permitted. By applying the criteria and methodologies the Procuring Entity shall determine the Best Evaluated Tender in accordance with ITT 40.

37.2 To evaluate a Tender, the Procuring Entity shall consider the following:

- a) price adjustment due to discounts offered in accordance with ITT 16;
- b) converting the amount resulting from applying (a) and (b) above, if relevant, to a single currency in accordance with ITT 39;
- c) price adjustment due to quantifiable non-material non-conformities in accordance with ITT 30.3; and
- d) any additional evaluation factors specified in the **TDS** and Section III, Evaluation and Qualification Criteria.

37.3 The estimated effect of the price adjustment provisions of the Conditions of Contract, applied over the period of execution of the Contract, shall not be considered in Tender evaluation.

37.4 In the case of multiple contracts or lots, Tenderers shall be allowed to tender for one or more lots and the methodology to determine the lowest evaluated cost of the lot (contract) combinations, including any discounts offered in the Form of Tender, is specified in Section III, Evaluation and Qualification Criteria.

38. Comparison of Tenders

38.1 The Procuring Entity shall compare the evaluated costs of all substantially responsive Tenders established in accordance with ITT 38.2 to determine the Tender that has the lowest evaluated cost.

39. Abnormally Low Tenders

39.1 An Abnormally Low Tender is one where the Tender price, in combination with other elements of the Tender, appears so low that it raises material concerns as to the capability of the Tenderer in regards to the Tenderer's ability to perform the Contract for the offered Tender Price or that genuine competition between Tenderers is compromised.

39.2 In the event of identification of a potentially Abnormally Low Tender, the Procuring Entity shall seek written clarifications from the Tenderer, including detailed price analyses of its Tender price in relation to the subject matter of the contract, scope, proposed methodology, schedule, allocation of risks and responsibilities and any

other requirements of the Tender document.

39.3 After evaluation of the price analyses, in the event that the Procuring Entity determines that the Tenderer has failed to demonstrate its capability to perform the Contract for the offered Tender Price, the Procuring Entity shall reject the Tender.

40. Abnormally High Tenders

40.1 An abnormally high price is one where the tender price, in combination with other constituent elements of the Tender, appears unreasonably too high to the extent that the Procuring Entity is concerned that it (the Procuring Entity) may not be getting value for money or it may be paying too high a price for the contract compared with market prices or that genuine competition between Tenderers is compromised.

40.2 In case of an abnormally high tender price, the Procuring Entity shall make a survey of the market prices, check if the estimated cost of the contract is correct and review the Tender Documents to check if the specifications, scope of work and conditions of contract are contributory to the abnormally high tenders. The Procuring Entity may also seek written clarification from the tenderer on the reason for the high tender price. The Procuring Entity shall proceed as follows:

- i) If the tender price is abnormally high based on wrong estimated cost of the contract, the Procuring Entity may accept or not accept the tender depending on the Procuring Entity's budget considerations.
- ii) If specifications, scope of work and/or conditions of contract are contributory to the abnormally high tender prices, the Procuring Entity shall reject all tenders and may retender for the contract based on revised estimates, specifications, scope of work and conditions of contract, as the case may be.

40.3 If the Procuring Entity determines that the Tender Price is abnormally too high because genuine competition between tenderers is compromised (*often due to collusion, corruption or other manipulations*), the Procuring Entity shall reject all Tenders and shall institute or cause competent Government Agencies to institute an investigation on the cause of the compromise, before retendering.

41. Unbalanced and/or Front-Loaded Tenders

41.1 If in the Procuring Entity's opinion, the Tender that is evaluated as the lowest evaluated price is seriously unbalanced and/or front loaded, the Procuring Entity may require the Tenderer to provide written clarifications. Clarifications may include detailed price analyses to demonstrate the consistency of the tender prices with the scope of works, proposed methodology, schedule and any other requirements of the Tender document.

41.2 After the evaluation of the information and detailed price analyses presented by the Tenderer, the Procuring Entity may as appropriate:

- a) accept the Tender; or
- b) require that the total amount of the Performance Security be increased at the expense of the Tenderer to a level not exceeding a 30% of the Contract Price; or
- c) agree on a payment mode that eliminates the inherent risk of the Procuring Entity paying too much for undelivered works; or
- d) reject the Tender,

42. Qualifications of the Tenderer

42.1 The Procuring Entity shall determine to its satisfaction whether the eligible Tenderer that is selected as having submitted the lowest evaluated cost and substantially responsive Tender, meets the qualifying criteria specified in Section III, Evaluation and Qualification Criteria.

42.2 The determination shall be based upon an examination of the documentary evidence of the Tenderer's qualifications submitted by the Tenderer, pursuant to ITT 19. The determination shall not take into consideration the qualifications of other firms such as the Tenderer's subsidiaries, parent entities, affiliates, subcontractors (other than Specialized Subcontractors if permitted in the Tender document), or any other firm(s) different from the Tenderer.

42.3 An affirmative determination shall be a prerequisite for award of the Contract to the Tenderer. A negative determination shall result in disqualification of the Tender, in which event the Procuring Entity shall proceed to the Tenderer who offers a substantially responsive Tender with the next lowest evaluated price to make a similar determination of that Tenderer's qualifications to perform satisfactorily.

42.4 An Abnormally Low Tender is one where the Tender price, in combination with other elements of the Tender, appears so low that it raises material concerns as to the capability of the Tenderer in regards to the Tenderer's ability to perform the Contract for the offered Tender Price.

42.5 In the event of identification of a potentially Abnormally Low Tender, the Procuring Entity shall seek written clarifications from the Tenderer, including detailed price analyses of its Tender price in relation to the subject matter of the contract, scope, proposed methodology, schedule, allocation of risks and responsibilities and any other requirements of the Tender document.

42.6 After evaluation of the price analyses, if the Procuring Entity determines that the Tenderer has failed to demonstrate its capability to perform the Contract for the offered Tender Price, the Procuring Entity shall reject the Tender.

43. Best Evaluated Tender

43.1 Having compared the evaluated prices of Tenders, the Procuring Entity shall determine the Best Evaluated Tender. The Best Evaluated Tender is the Tender of the Tenderer that meets the Qualification Criteria and whose Tender has been determined to be:

- a) Most responsive to the Tender document; and
- b) the lowest evaluated price.

44. Procuring Entity's Right to Accept Any Tender, and to Reject Any or All Tenders.

44.1 The Procuring Entity reserves the right to accept or reject any Tender and to annul the Tender process and reject all Tenders at any time prior to Contract Award, without thereby incurring any liability to Tenderers. In case of annulment, all Tenderers shall be notified with reasons and all Tenders submitted and specifically, Tender securities, shall be promptly returned to the Tenderers.

F. Award of Contract

45. Award Criteria

45.1 The Procuring Entity shall award the Contract to the successful tenderer whose tender has been determined to be the Lowest Evaluated Tender.

46. Notice of Intention to enter into a Contract

46.1 Upon award of the contract and Prior to the expiry of the Tender Validity Period the Procuring Entity shall issue a Notification of Intention to Enter into a Contract / Notification of award to all tenderers which shall contain, at a minimum, the following information:

- a) the name and address of the Tenderer submitting the successful tender;
- b) the Contract price of the successful tender;
- c) a statement of the reason(s) the tender of the unsuccessful tenderer to whom the letter is addressed was unsuccessful, unless the price information in (c) above already reveals the reason;
- d) the expiry date of the Standstill Period; and
- e) instructions on how to request a debriefing and/or submit a complaint during the standstill period;

47. Standstill Period

47.1 The Contract shall not be signed earlier than the expiry of a Standstill Period of 14 days to allow any dissatisfied tender to launch a complaint. Where only one Tender is submitted, the Standstill Period shall not apply.

47.2 Where a Standstill Period applies, it shall commence when the Procuring Entity has transmitted to each Tenderer the Notification of Intention to Enter **into a Contract with the successful Tenderer.**

48. Debriefing by the Procuring Entity

48.1 On receipt of the Procuring Entity's Notification of Intention to Enter into a Contract referred to in ITT 46, an unsuccessful tenderer may make a written request to the Procuring Entity for a debriefing on specific issues or

concerns regarding their tender. The Procuring Entity shall provide the debriefing within five days of receipt of the request.

48.2 Debriefings of unsuccessful Tenderers may be done in writing or verbally. The Tenderer shall bear its own costs of attending **such a debriefing meeting**.

49. Letter of Award

49.1 Prior to the expiry of the Tender Validity Period and upon expiry of the Standstill Period specified in ITT 42.1, upon addressing a complaint that has been filed within the Standstill Period, the Procuring Entity shall transmit the Letter of Award to the successful Tenderer. The letter of award shall request the successful tenderer to furnish the Performance Security within 21 days of the date of the letter.

50. Signing of Contract

50.1 Upon the expiry of the fourteen days of the Notification of Intention to enter into contract and upon the parties meeting their respective statutory requirements, the Procuring Entity shall send the successful Tenderer the Contract Agreement.

50.2 Within fourteen (14) days of receipt of the Contract Agreement, the successful Tenderer shall sign, date, and return it to the Procuring Entity.

50.3 The written contract shall be entered into within the period specified in the notification of award and before expiry of the tender validity period

51. Appointment of Adjudicator

51.1 The Procuring Entity proposes the person named in the **TDS** to be appointed as Adjudicator under the Contract, at the hourly fee specified in the **TDS**, plus reimbursable expenses. If the Tenderer disagrees with this proposal, the Tenderer should so state in his Tender. If, in the Letter of Acceptance, the Procuring Entity does not agree on the appointment of the Adjudicator, the Procuring Entity will request the Appointing Authority designated in the Special Conditions of Contract (SCC) pursuant to Clause 23.1 of the General Conditions of Contract (GCC), to appoint the Adjudicator.

52. Performance Security

52.1 Within twenty-one (21) days of the receipt of the Letter of Acceptance from the Procuring Entity, the successful Tenderer shall furnish the Performance Security and, any other documents required in the **TDS**, in accordance with the General Conditions of Contract, subject to ITT 40.2 (b), using the Performance Security and other Forms included in Section X, Contract Forms, or another form acceptable to the Procuring Entity. A foreign institution providing a bank guarantee shall have a correspondent financial institution located in Kenya, unless the Procuring Entity has agreed in writing that a correspondent bank is not required.

52.2 Failure of the successful Tenderer to submit the above-mentioned Performance Security and other documents required in the **TDS**, or sign the Contract shall constitute sufficient grounds for the annulment of the award and forfeiture of the Tender Security. In that event the Procuring Entity may award the Contract to the Tenderer offering the next Best Evaluated Tender.

52.3 Performance security shall not be required for contracts estimated to cost less than Kenya shillings five million shillings.

53. Publication of Procurement Contract

53.1 Within fourteen days after signing the contract, the Procuring Entity shall publish the awarded contract at its notice boards and websites; and on the Website of the Authority. At the minimum, the notice shall contain the following information:

- a) name and address of the Procuring Entity;
- b) name and reference number of the contract being awarded, a summary of its scope and the selection method used;
- c) the name of the successful Tenderer, the final total contract price, the contract duration.

- d) dates of signature, commencement and completion of contract;
- e) names of all Tenderers that submitted Tenders, and their Tender prices as read out at Tender opening.

54. Procurement Related Complaints and Administrative Review

54.1 The procedures for making Procurement-related Complaints are specified in the **TDS**.

54.2 A request for administrative review shall be made in the form provided under contract forms.

Section II - Tender Data Sheet (TDS)

The following specific data shall complement, supplement, or amend the provisions in the Instructions to Tenderers (ITT). Whenever there is a conflict, the provisions herein shall prevail over those in ITT.

ITT Reference	PARTICULARS OF APPENDIX TO INSTRUCTIONS TO TENDERS
	A. General
ITT 1.1	<p>The name of the contract is PROPOSED CONSTRUCTION OF CLIMATE CHANGE INFORMATION CENTRE DEVELOPMENT CENTRE IN SOKONI WARD – KILIFI MUNICIPALITY</p> <p>The reference number of the Contract is KCG/ENVRM/OT/FLOCCA /2225736/2025/2026</p> <p>The number and identification of lots (contracts) comprising this Tender are N/A</p>
ITT 2.3	The Information made available on competing firms is as follows: N/A
ITT 2.4	The firms that provided consulting services for the contract being tendered for are: N/A
ITT 3.1	Maximum number of members in the Joint Venture (JV) shall be: [5] .
	B. Contents of Tender Document
8.1	<p>(A) Pre-Tender conference <i>shall</i> take place</p> <p>(B) A pre-arranged pretender visit of the site of the works <i>shall</i> take place at the following date, time and place: Date: 29th JUNE, 2026 Time: 10.00 a,m Place: Contractors to meet at COUNTY WATER AND ENVIRONMENT HEADQUARTERS OFFICE.</p>
ITT 8.2	The Tenderer will submit any questions in writing, to reach the Procuring Entity not later than 3RD JULY, 2026
ITT 8.4	The Procuring Entity's website where Minutes of the pre-Tender meeting and the pre-arranged pretender site visit will be published is www.kilifi.go.ke
ITT 9.1	<p>For Clarification of Tender purposes, for obtaining further information and for purchasing tender documents, the Procuring Entity's address is:</p> <p>County Government of Kilifi, P.o Box 519-80108, Kilifi. Head of Supply Chain Management Email: supplychain@kilifi.go.ke</p>
	C. Preparation of Tenders
ITP 13.1 (h)	The Tenderer shall submit the following additional documents in its Tender: N/A
ITT 15.1	Alternative Tenders <i>shall not be</i> considered.
ITT 15.2	Alternative times for completion <i>shall not be</i> permitted.
ITT 16.5	The prices quoted by the Tenderer shall be <i>fixed</i>
ITT 20.1	The Tender validity period shall be 147 days.
ITT 20.3 (a)	

ITT Reference	PARTICULARS OF APPENDIX TO INSTRUCTIONS TO TENDERS
	<p>(b) The Tender price shall be adjusted by the following percentages of the tender price:</p> <p>(i) By <u> 0 </u> % of the local currency portion of the Contract price adjusted to reflect local inflation during the period of extension, N/A and</p> <p>(ii) By <u> 0 </u> % the foreign currency portion of the Contract price adjusted to reflect the international inflation during the period of extension. N/A</p>
ITT 21.1	<p>A Tender Security shall be required.</p> <p>A Tender-Securing Declaration shall not be required.</p> <p>If a Tender Security shall be required, the amount and currency of the Tender Security shall be Kshs. 650,000/=</p>
ITT 21.2 (d)	The other Tender Security shall be N/A
ITT 21.5	On the Performance Security, other documents required shall be N/A
ITT 22.1	In addition to the original of the Tender, the number of copies is: N/A
ITT 22.3	The written confirmation of authorization to sign on behalf of the Tenderer shall consist of power of attorney indicating the name of the person to sign the tender document and execute the contract
D. Submission and Opening of Tenders	
ITT 24.1	<p>(A) For <u>Tender submission purposes</u> only, the Procuring Entity's address is:</p> <p>County Government of Kilifi, P.o Box 519-80108 Kilifi. IFMIS PORTAL Date and time for submission of Tenders is 3RD JULY, 2026 at 11:30 am Tenderers shall submit tenders electronically.</p>
ITT 27.1	<p>The Tender opening shall take place at the time and the address for Opening of Tenders provided below:</p> <p>County Government of Kilifi, P.o Box 519-80108 Kilifi. IFMIS PORTAL Date and time of tender opening is 3RD JULY, 2026 at 11:30 am</p>
ITT 27.1	If Tenderers are allowed to submit Tenders electronically, they shall follow the electronic tender submission procedures specified by the national treasury in the
ITT 27.6	The number of representatives of the Procuring Entity to sign is 3.
E. Evaluation, and Comparison of Tenders	
ITT 32.3	The adjustment shall be based on the <i>average</i> price of the item or component as quoted in other substantially responsive Tenders. If the price of the item or component cannot be derived from the price of other substantially responsive Tenders, the Procuring Entity shall use its best estimate.

ITT Reference	PARTICULARS OF APPENDIX TO INSTRUCTIONS TO TENDERS
ITT 35.2	The invitation to tender is extended to the following groups that qualify for Reservations
ITT 36.1	At this time, the Procuring Entity <i>does not intend</i> to execute certain specific parts of the Works by subcontractors selected in advance.
ITT 36.2	Contractor's may propose subcontracting: Maximum percentage of subcontracting permitted is: 40% of the total contract amount . Tenderers planning to subcontract more than 10% of total volume of work shall specify, in the Form of Tender, the activity (ies) or parts of the Works to be subcontracted along with complete details of the subcontractors and their qualification and experience.
ITT 36.3	<p>The parts of the Works for which the Procuring Entity permits Tenderers to propose Specialized Subcontractors are designated as follows: N/A</p> <p>For the above-designated parts of the Works that may require Specialized Subcontractors, the relevant qualifications of the proposed Specialized Subcontractors will be added to the qualifications of the Tenderer for the purpose of evaluation.</p>
ITT 37.2 (d)	Additional requirements apply. These are detailed in the evaluation criteria in Section III, Evaluation and Qualification Criteria.
ITT 51.1	The person named to be appointed as Adjudicator is N/A
ITT 52.2	Other documents required are N/A
ITT 54.1	<p>The procedures for making a Procurement-related Complaints are detailed in the "Regulations" available from the PPRA Website www.ppra.go.ke or email complaints@ppra.go.ke. If a Tenderer wishes to make a Procurement-related Complaint, the Tenderer should submit its complaint following these procedures, in writing (by the quickest means available, that is either by hand delivery or email to:</p> <p>For the attention: JACINTA ISMAIL Title/position:</p> <p>Accounting officer Entity: County Government of Kilifi Email address: supplychain@kilifi.go.ke</p> <p>In summary, a Procurement-related Complaint may challenge any of the following:</p> <ul style="list-style-type: none"> (i) the terms of the Tender Documents; and (ii) the Procuring Entity's decision to award the contract.

SECTION III - EVALUATION AND QUALIFICATION CRITERIA

1. General Provisions

Wherever a Tenderer is required to state a monetary amount, Tenderers should indicate the Kenya Shilling equivalent using the rate of exchange determined as follows:

- a) For construction turnover or financial data required for each year - Exchange rate prevailing on the last day of the respective calendar year (in which the amounts for that year is to be converted) was originally established.
- b) Value of single contract - Exchange rate prevailing on the date of the contract signature.
- c) Exchange rates shall be taken from the publicly available source identified in the ITT 14.3. Any error in determining the exchange rates in the Tender may be corrected by the Procuring Entity.

This section contains the criteria that the Employer shall use to evaluate tender and qualify tenderers. No other factors, methods or criteria shall be used other than specified in this tender document. The Tenderer shall provide all the information requested in the forms included in Section IV, Tendering Forms. The Procuring Entity should use **the Standard Tender Evaluation Document for Goods and Works** for evaluating Tenders.

Evaluation and contract award Criteria

The Procuring Entity shall use the criteria and methodologies listed in this Section to evaluate tenders and arrive at the Lowest Evaluated Tender. The tender that (i) meets the qualification criteria, (ii) has been determined to be substantially responsive to the Tender Documents, and (iii) is determined to have the Lowest Evaluated Tender price shall be selected for award of contract.

2. Preliminary examination for Determination of Responsiveness

The Procuring Entity will start by examining all tenders to ensure they meet in all respects the eligibility criteria and other requirements in the ITT, and that the tender is complete in all aspects in meeting the requirements of "Part 2 – Procuring Entity's Works Requirements", including checking for tenders with unacceptable errors, abnormally low tenders, abnormally high tenders and tenders that are front loaded. The Standard Tender Evaluation Report Document for Goods and Works for evaluating Tenders provides very clear guide on how to deal with review of these requirements. Tenders that do not pass the Preliminary Examination will be considered irresponsible and will not be considered further

PRELIMINARY EXAMINATION

PARTICULARS OF APPENDIX TO INSTRUCTIONS TO TENDERERS	RESPONSIVE/ NON RESPONSIVE
Tenderers are required to submit copies of the following MANDATORY DOCUMENTS which will be used during preliminary examination to determine responsiveness:	
<ol style="list-style-type: none">1. A copy of certificate of Registration/Incorporation2. A valid CR12 of not more than 1 year or copies of ID cards for business names.3. A Copy of Valid Tax Compliance Certificate from Kenya Revenue Authority4. A Copy of KRA PIN Certificate.5. Valid annual practicing license from National Construction Authority for Building works.6. Must Fill the Bills of Quantities and Price Schedule in the format provided without any alterations whatsoever.7. A valid Single Business Permit.8. Bid document must be sequentially paginated/serialized, including all attachments.9. The tenderer must submit a duly filled, signed and stamped Confidential Business Questionnaire.10. Self-declaration in non-engagement in corruption/non PPRA debarment.11. Attach a site visit certificate signed by an authorized officer in charge.12. Attach a bid bond of Kshs 650,000 from a reputable firm.13. Attach an NCA 6 and above certificate for Building works from National Construction Authority.14. Duly filled, signed and stamped form of tender.	

Tenderers that are non-responsive will be eliminated from the entire evaluation process and will not be considered further

3 Tender Evaluation (ITT 35) Price evaluation: in addition to the criteria listed in ITT 35.2 (a)–(c) the following

criteria shall apply:

- i) **Alternative Completion Times**, if permitted under ITT 13.2, will be evaluated as follows: N/A
- ii) **Alternative Technical Solutions** for specified parts of the Works, if permitted under ITT 13.4, will be evaluated as follows: N/A
- iii) **Other Criteria**; if permitted under ITT 35.2(d): N/A

4 Post qualification and Contract award (ITT 39), more specifically,

- a) In case the tender was subject to post-qualification, the contract shall be awarded to the lowest evaluated tenderer, subject to confirmation of pre-qualification data, if so required.
- b) In case the tender was not subject to post-qualification, the tender that has been determined to be the lowest evaluated tenderer shall be considered for contract award, subject to meeting each of the following conditions.
 - i) The Tenderer shall demonstrate that it has access to, or has available, liquid assets, unencumbered real assets, lines of credit, and other financial means (independent of any contractual advance payment) sufficient to meet the construction cash flow of Kenya Shillings
 - ii) Minimum average annual construction turnover of Kenya Shillings 10,000,000.00, equivalent calculated as total certified payments received for contracts in progress and/or completed within the last 5 years.
 - iii) At least 3 contract(s) of a similar nature executed within Kenya, or the East African Community or abroad, that have been satisfactorily and substantially completed as a prime contractor, or joint venture member or sub-contractor each of minimum value Kenya shillings 10,000,000.00 equivalent.
 - iv) Contractor's Representative and Key Personnel, which are specified as below

Designation	Minimum requirement	No. required
Site Agent	Qualification: A degree in relevant field Specific experience in similar works: 7 years	1

- v) Contractors key equipment listed on the table “Contractor's Equipment” below and more specifically listed as below

Item No.	Equipment details	No. required
A	Grader	1
B	Drum rollers	1
C	Excavator	1
D	Water booser	1
E	Bulldozer	1
F	Lorries	3

- vi) Other conditions depending on their seriousness.
 - a) History of non-performing contracts:

Tenderer and each member of JV in case the Tenderer is a JV, shall demonstrate that Non-performance of a contract did not occur because of the default of the Tenderer, or the member of a JV in the last 5 years. The required information shall be furnished in the appropriate form.

- b) **Pending Litigation**
Financial position and prospective long-term profitability of the Single Tenderer, and in the case the Tenderer is a JV, of each member of the JV, shall remain sound according to criteria established with respect to Financial Capability under Paragraph (i) above if all pending litigation will be resolved against the Tenderer. Tenderer shall provide information on pending litigations in the appropriate form.
- c) **Litigation History**
There shall be no consistent history of court/arbitral award decisions against the Tenderer, in the last 5 years. All parties to the contract shall furnish the information in the appropriate form about any litigation or arbitration resulting from contracts completed or ongoing under its execution over the years specified. A consistent history of awards against the Tenderer or any member of a JV may result in rejection of the tender.

5. QUALIFICATION FORM SUMMARY

1	2	3	4	5
Item No.	Qualification Subject	Qualification Requirement	Document To be Completed by Tenderer	For Procuring Entity's Use (Qualification met or Not Met)
1	Nationality	Nationality in accordance with ITT 3.6	Forms ELI – 1.1 and 1.2, with attachments	
2	Tax Obligations for Kenyan Tenderers	Has produced a current tax clearance certificate or tax exemption certificate issued by the the Kenya Revenue Authority in accordance with ITT 3.14.	Form of Tender	
3	Conflict of Interest	No conflicts of interest in accordance with ITT 3.3	Form of Tender	
4	PPRA Eligibility	Not having been declared ineligible by the PPRA as described in ITT 3.8	Form of Tender	
5	State- owned Enterprise	Meets conditions of ITT 3.7	Forms ELI – 1.1 and 1.2, with attachments	
6	Goods, equipment and services to be supplied under the contract	To have their origin in any country that is not determined ineligible under ITT 4.1	Forms ELI – 1.1 and 1.2, with attachments	
7	History of Non-Performing Contracts	Non-performance of a contract did not occur as a result of contractor default since 1 st January 2019	Form CON-2	
8	Suspension Based on Execution of Tender/Proposal Securing Declaration by the Procuring Entity	Not under suspension based on-execution of a Tender/Proposal Securing Declaration pursuant to ITT 19.9	Form of Tender	
9	Pending Litigation	Tender's financial position and prospective long-term profitability still sound according to criteria established in 3.1 and assuming that all pending litigation will NOT be resolved against the Tenderer.	Form CON – 2	
10	Litigation History	No consistent history of court/arbitral award decisions against the Tenderer since 1 st January 2019	Form CON – 2	
11	Financial Capabilities	(i) The Tenderer shall demonstrate that it has access to, or has available, liquid	Form FIN – 3.1, with attachments	

1	2	3	4	5
Item No.	Qualification Subject	Qualification Requirement	Document To be Completed by Tenderer	For Procuring Entity's Use (Qualification met or Not Met)
		<p>assets, unencumbered real assets, lines of credit, and other financial means (independent of any contractual advance payment) sufficient to meet the construction cash flow requirements estimated as Kenya Shillings 1,000,000.00 or (10% of the budget) equivalent for the subject contract(s) net of the Tenderer's other commitments.</p> <p>(ii) The Tenderers shall also demonstrate, to the satisfaction of the Procuring Entity, that it has adequate sources of finance to meet the cash flow requirements on works currently in progress and for future contract commitments.</p> <p>(iii) The audited balance sheets or, if not required by the laws of the Tenderer's country, other financial statements acceptable to the Procuring Entity, for the last 3 years shall be submitted and must demonstrate the current soundness of the Tenderer's financial position and indicate its prospective long-term profitability.</p>		
12	Average Annual Construction Turnover	Minimum average annual construction turnover of Kenya Shillings 10,000,000.00, equivalent calculated as total certified payments received for contracts in progress and/or completed within the last 5 years, divided by 5 years	Form FIN – 3.2	
13	General Construction Experience	Experience under construction contracts in the role of prime contractor, JV member, sub-contractor, or management contractor for at least the last 5 years, starting 1 st January 2019.	Form EXP – 4.1	
14	Specific Construction & Contract Management Experience	A minimum number of 3 similar contracts specified below that have been satisfactorily and substantially completed as a prime contractor, joint venture member, management	Form EXP 4.2(a)	

1	2	3	4	5
Item No.	Qualification Subject	Qualification Requirement	<i>Document To be Completed by Tenderer</i>	<i>For Procuring Entity's Use (Qualification met or Not Met)</i>
		<p>contractor or sub-contractor between 1st January 2019 and tender submission deadline i.e. 3 contracts, each of minimum value Kenya shillings 10,000,000.00 equivalent. <i>[In case the Works are to be tender as individual contracts under multiple contract procedure, the minimum number of contracts required for purposes of evaluating qualification shall be selected from the options mentioned in ITT 35.4]</i></p> <p>The similarity of the contracts shall be based on the following: <i>[Based on Section VII, Scope of Works, specify the minimum key requirements in terms of physical size, complexity, construction method, technology and/or other characteristics including part of the requirements that may be met by specialized subcontractors, if permitted in accordance with ITT 34.3]</i></p>		

SUMMARY OF POST-QUALIFICATION CRITERIA

ITEM	DESCRIPTION	SCORE
1	KEY PERSONNEL	
	<p>Evidence of Qualified and Experienced personnel of at least 4 Key personnel to undertake the specified works .Attach CV’s with copies of academic and professional certificates including letters of appointment and consents to work for the firm of Technical Staff (building engineering), with TWO 2 NO. minimum registered as Professional Engineers by the Engineers Board of Kenya and Valid Practicing Licenses,</p> <p style="text-align: center;">(15 Mrks)</p> <p>A. Degree Holders with 10 years’ experience for Two(2 no) Key Technical staff – 15 mrk</p> <p>i. One (1) No. Technical staff –7.5 mrks ii. No technical staff - 0 mrks</p> <p>B. Degree/Diploma in (building engineering) Two (2no) technical staff – Two technical staff registered with Engineers Board of Kenya with 3 years’ Experience 15Mrks</p> <p>i) Degree/Diploma in (building engineering) One (1no) technical staff – One technical staff registered with Engineers Board of Kenya 7.5Mrks ii) no registration -0mrks</p>	30
2	PLANT AND EQUIPMENTS	
	<p>3 No. Lorry - 3mrks 1 NO. Poker Vibrator - 4mrks 1 No. Concrete Mixer - 4mrk 1 No. Bar Bending Machine - 4mrk</p> <p>Provide evidence of Ownership/possession , lease or hire agreement.</p>	15
3	EXPERIENCE	
	<p>Implementation of Six (6) previous assignments/ contracts, MUST attach LSO/LPO against completion certificates, Contract Agreements, Letters of Awards, certificates of Good defects and Letters of Recommendations for works of at least Six in number projects of the same Nature and Magnitude.</p> <p>i Similar works, same magnitude– 20 mrks. ii Similar works, less magnitude– 10 mrks</p>	20
4	FINANCIAL CAPACITY	
	<p>Tenderer must submit copies of certified Audited Financial Accounts for thelast 3 years (2023, 2024& 2025.)</p> <p>-three years- 10marks -two years-6marks One year-3marks</p>	15
5	DETAILED WORK PLAN/METHODOLOGY	
	<p>Show How You Shall Under Take The Works Highlighting All the Steps and procedures for the entire period of the contract and a detailed work schedule indicating all the timelines to be spent on all the relevant project phases of the</p>	10

	project.	
6	BQ RATES	
	Consistency and reasonability of rates with approved estimates, possible front-loading of bill items will result to zero marks	10
	TOTAL MARKS	100

Tenderers **MUST** have a minimum score of **60** to be subjected to financial evaluation.

The lowest evaluated bidder shall be awarded the tender.

QUALIFICATION FORMS

1. FORMEQU: EQUIPMENT

The Tenderer shall provide adequate information to demonstrate clearly that it has the capability to meet the requirements for the key equipment listed in Section III, Evaluation and Qualification Criteria. A separate Form shall be prepared for each item of equipment listed, or for alternative equipment proposed by the Tenderer.

Item of equipment		
Equipment information	Name of manufacturer	Model and power rating
	Capacity	Year of manufacture
Current status	Current location	
	Details of current commitments	
Source	Indicate source of the equipment <input type="checkbox"/> Owned <input type="checkbox"/> Rented <input type="checkbox"/> Leased <input type="checkbox"/> Specially manufactured	

Omit the following information for equipment owned by the Tenderer.

Owner	Name of owner	
	Address of owner	
	Telephone	Contact name and title
	Fax	Telex
Agreements	Details of rental / lease / manufacture agreements specific to the project	

2. FORM PER -1

Contractor's Representative and Key Personnel Schedule

Tenderers should provide the names and details of the suitably qualified Contractor's Representative and Key Personnel to perform the Contract. The data on their experience should be supplied using the Form PER-2 below for each candidate.

Contractor' Representative and Key Personnel

1.	Title of position: Contractor's Representative	
	Name of candidate:	
	Duration of appointment:	
	Time commitment: for this position:	
	Expected time schedule for this position:	
2.	Title of position: _____	
	Name of candidate:	
	Duration of appointment:	
	Time commitment: for this position:	
	Expected time schedule for this position:	
3.	Title of position: _____	
	Name of candidate:	
	Duration of appointment:	
	Time commitment: for this position:	
	Expected time schedule for this position:	
4.	Title of position: _____	
	Name of candidate:	
	Duration of appointment:	
	Time commitment: for this position:	
	Expected time schedule for this position:	
5.	Title of position:	
	Name of candidate	
	Duration of appointment:	
	Time commitment: for this position:	
	Expected time schedule for this position:	

3. **FORM PER-2:**

Resume and Declaration - Contractor's Representative and Key Personnel.

Summarize professional experience in reverse chronological order. Indicate particular technical and managerial experience relevant to the project.

Name of Tenderer

Position		
Personnel information	Name:	Date of birth:
	Address:	E-mail:
	Professional qualifications:	
	Academic qualifications:	
	Language proficiency:	
Details	Address of Procuring Entity:	
	Telephone:	Contact (manager / personnel officer):
	Fax:	
	Job title:	Years with present Procuring Entity:

Summarize professional experience in reverse chronological order. Indicate particular technical and managerial experience relevant to the project.

Project	Role	Duration of involvement	Relevant experience
<i>[main project details]</i>	<i>[role and responsibilities on the project]</i>	<i>[time in role]</i>	<i>[describe the experience relevant to this position]</i>

Declaration

I, the undersigned *Key Personnel*, certify that to the best of my knowledge and belief, the information contained in this Form PER-2 correctly describes myself, my qualifications and my experience.

I confirm that I am available as certified in the following table and throughout the expected time schedule for this position as provided in the Tender:

Commitment	Details
Commitment to duration of contract:	
Time commitment:	

I understand that any misrepresentation or omission in this Form may:

- a) be taken into consideration during Tender evaluation;
- b) result in my disqualification from participating in the Tender;
- c) result in my dismissal from the contract.

Name of Contractor's Representative or Key Personnel: *[insert name]*

Signature: _____

Date: (day month year): _____ Countersignature

of authorized representative of the Tenderer:

Signature: _____ Date: (day month

year): _____

4 TENDERER'S QUALIFICATION WITHOUT PRE-QUALIFICATION

To establish its qualifications to perform the contract in accordance with Section III, Evaluation and Qualification Criteria the Tenderer shall provide the information requested in the corresponding Information Sheets included hereunder.

4.1 FORM ELI -1.1

Tenderer Information Form

Date: _____

ITT No. and title: _____

Tenderer's name
In case of Joint Venture (JV), name of each member:
Tenderer's actual or intended country of registration: <i>[indicate country of Constitution]</i>
Tenderer's actual or intended year of incorporation:
Tenderer's legal address [in country of registration]:
Tenderer's authorized representative information Name: _____ Address: _____ Telephone/Fax numbers: _____ E-mail address: _____
1. Attached are copies of original documents of <input type="checkbox"/> Articles of Incorporation (or equivalent documents of constitution or association), and/or documents of registration of the legal entity named above, in accordance with ITT 3.6 <input type="checkbox"/> In case of JV, letter of intent to form JV or JV agreement, in accordance with ITT 3.5 <input type="checkbox"/> In case of state-owned enterprise or institution, in accordance with ITT 3.8, documents establishing: <ul style="list-style-type: none">• Legal and financial autonomy• Operation under commercial law• Establishing that the Tenderer is not under the supervision of the Procuring Entity
2. Included are the organizational chart, a list of Board of Directors, and the beneficial ownership.

4.2 FORM ELI -1.2

Tenderer's JV Information Form **(to be completed for each member of Tenderer's JV)**

Date: _____

ITT No. and title: _____

Tenderer's JV name:
JV member's name:
JV member's country of registration:
JV member's year of constitution:
JV member's legal address in country of constitution:
JV member's authorized representative information Name: _____ Address: _____ Telephone/Fax numbers: _____ E-mail address: _____
1. Attached are copies of original documents of <input type="checkbox"/> Articles of Incorporation (or equivalent documents of constitution or association), and/or registration documents of the legal entity named above, in accordance with ITT 3.6. <input type="checkbox"/> In case of a state-owned enterprise or institution, documents establishing legal and financial autonomy, operation in accordance with commercial law, and that they are not under the supervision of the Procuring Entity, in accordance with ITT 3.8. 2. Included are the organizational chart, a list of Board of Directors, and the beneficial ownership.

4.3 FORM CON – 2

Historical Contract Non-Performance, Pending Litigation and Litigation History

Tenderer's Name: _____

Date: _____

JV Member's Name _____

ITT No. and title: _____

Non-Performed Contracts in accordance with Section III, Evaluation and Qualification Criteria			
<input type="checkbox"/> Contract non-performance did not occur since 1 st January [insert year] specified in Section III, Evaluation and Qualification Criteria, Sub-Factor 2.1.			
<input type="checkbox"/> Contract(s) not performed since 1 st January [insert year] specified in Section III, Evaluation and Qualification Criteria, requirement 2.1			
Year	Non-performed portion of contract	Contract Identification	Total Contract Amount (current value, currency, exchange rate and Kenya Shilling equivalent)
[insert year]	[insert amount and percentage]	Contract Identification: [indicate complete contract name/ number, and any other identification] Name of Procuring Entity: [insert full name] Address of Procuring Entity: [insert street/city/country] Reason(s) for nonperformance: [indicate main reason(s)]	[insert amount]
Pending Litigation, in accordance with Section III, Evaluation and Qualification Criteria			
<input type="checkbox"/> No pending litigation in accordance with Section III, Evaluation and Qualification Criteria, Sub-Factor 2.3.			
<input type="checkbox"/> Pending litigation in accordance with Section III, Evaluation and Qualification Criteria, Sub-Factor 2.3 as indicated below.			

Year of dispute	Amount in dispute (currency)	Contract Identification	Total Contract Amount (currency), Kenya Shilling Equivalent (exchange rate)
		Contract Identification: _____ Name of Procuring Entity: _____ Address of Procuring Entity: _____ Matter in dispute: _____ Party who initiated the dispute: Status of dispute: _____	
		Contract Identification: Name of Procuring Entity: Address of Procuring Entity: Matter in dispute: Party who initiated the dispute: Status of dispute:	

Litigation History in accordance with Section III, Evaluation and Qualification Criteria			
<input type="checkbox"/> No Litigation History in accordance with Section III, Evaluation and Qualification Criteria, Sub-Factor 2.4.			
<input type="checkbox"/> Litigation History in accordance with Section III, Evaluation and Qualification Criteria, Sub-Factor 2.4 as indicated below.			

Year of award	Outcome as percentage of Net Worth	Contract Identification	Total Contract Amount (currency), Kenya Shilling Equivalent (exchange rate)
<i>[insert year]</i>	<i>[insert percentage]</i>	Contract Identification: <i>[indicate complete contract name, number, and any other identification]</i> Name of Procuring Entity: <i>[insert full name]</i> Address of Procuring Entity: <i>[insert street/city/country]</i> Matter in dispute: <i>[indicate main issues in dispute]</i> Party who initiated the dispute: <i>[indicate "Procuring Entity" or "Contractor"]</i> Reason(s) for Litigation and award decision <i>[indicate main reason(s)]</i>	<i>[insert amount]</i>

4.4 FORM FIN – 3.1:

Financial Situation and Performance

Tenderer's Name: _____

Date: _____

JV Member's Name _____

ITT No. and title: _____

4.4.1. Financial Data

Type of Financial information in _____ (currency)	Historic information for previous _____ years, (amount in currency, currency, exchange rate*, USD equivalent)				
	Year 1	Year 2	Year 3	Year 4	Year 5
Statement of Financial Position (Information from Balance Sheet)					
Total Assets (TA)					
Total Liabilities (TL)					
Total Equity/Net Worth (NW)					
Current Assets (CA)					
Current Liabilities (CL)					
Working Capital (WC)					
Information from Income Statement					
Total Revenue (TR)					
Profits Before Taxes (PBT)					
Cash Flow Information					
Cash Flow from Operating Activities					

*Refer to ITT 15 for the exchange rate

4.4.2 Sources of Finance

Specify sources of finance to meet the cash flow requirements on works currently in progress and for future contract commitments.

No.	Source of finance	Amount (Kenya Shilling equivalent)
1		
2		
3		

4.4.3 Financial documents

The Tenderer and its parties shall provide copies of financial statements for _____ years pursuant Section III, Evaluation and Qualifications Criteria, Sub-factor 3.1. The financial statements shall:

- (a)..... reflect the financial situation of the Tenderer or in case of JV member, and not an affiliated entity (such as parent company or group member).
- (b) be independently audited or certified in accordance with local legislation.
- (c) be complete, including all notes to the financial statements.
- (d).....correspond to accounting periods already completed and audited.

Attached are copies of financial statements¹ for the _____ years required above; and complying with the requirements

¹ If the most recent set of financial statements is for a period earlier than 12 months from the date of Tender, the reason for this should be justified.

4.5 FORM FIN – 3.2:

Average Annual Construction Turnover

Tenderer's Name: _____

Date: _____

JV Member's Name _____

ITT No. and title: _____

Annual turnover data (construction only)			
Year	Amount Currency	Exchange rate	Kenya Shilling equivalent
<i>[indicate year]</i>	<i>[insert amount and indicate currency]</i>		
Average Annual Construction Turnover *			

* See Section III, Evaluation and Qualification Criteria, Sub-Factor 3.2.

4.6 FORM FIN – 3.3:

Financial Resources

Specify proposed sources of financing, such as liquid assets, unencumbered real assets, lines of credit, and other financial means, net of current commitments, available to meet the total construction cash flow demands of the subject contract or contracts as specified in Section III, Evaluation and Qualification Criteria

Financial Resources		
No.	Source of financing	Amount (Kenya Shilling equivalent)
1		
2		
3		

4.7 FORM FIN – 3.4:

Current Contract Commitments / Works in Progress

Tenderers and each member to a JV should provide information on their current commitments on all contracts that have been awarded, or for which a letter of intent or acceptance has been received, or for contracts approaching completion, but for which an unqualified, full completion certificate has yet to be issued.

Current Contract Commitments					
	Name of Contract	Procuring Entity's Contact Address, Tel,	Value of Outstanding Work [Current Kenya Shilling /month Equivalent]	Estimated Completion Date	Average Monthly Invoicing Over Last Six Months [Kenya Shilling /month]
1					
2					
3					
4					
5					

4.8 FORM EXP - 4.1

General Construction Experience

Tenderer's Name: _____

Date: _____

JV Member's Name _____

ITT No. and title: _____

Page _____ of _____ pages

Starting Year	Ending Year	Contract Identification	Role of Tenderer
		Contract name: _____ Brief Description of the Works performed by the Tenderer: _____ Amount of contract: _____ Name of Procuring Entity: _____ Address: _____	
		Contract name: _____ Brief Description of the Works performed by the Tenderer: _____ Amount of contract: _____ Name of Procuring Entity: _____ Address: _____	
		Contract name: _____ Brief Description of the Works performed by the Tenderer: _____ Amount of contract: _____ Name of Procuring Entity: _____ Address: _____	

4.9 FORM EXP - 4.2(a)**Specific Construction and Contract Management Experience**

Tenderer's Name: _____

Date: _____

JV Member's Name _____

ITT No. and title: _____

Similar Contract No.	Information			
Contract Identification				
Award date				
Completion date				
Role in Contract	Prime Contractor <input type="checkbox"/>	Member in JV <input type="checkbox"/>	Management Contractor <input type="checkbox"/>	Sub-contractor <input type="checkbox"/>
Total Contract Amount				Kenya Shilling
If member in a JV or sub-contractor, specify participation in total Contract amount				
Procuring Entity's Name:				
Address:				
Telephone/fax number				
E-mail:				

4.10 FORM EXP - 4.2 (a) (cont.)**Specific Construction and Contract Management Experience (cont.)**

Similar Contract No.	Information
Description of the similarity in accordance with Sub-Factor 4.2(a) of Section III:	
1. Amount	
2. Physical size of required works items	
3. Complexity	
4. Methods/Technology	
5. Construction rate for key activities	
6. Other Characteristics	

4.11 FORM EXP - 4.2(b)

Construction Experience in Key Activities

Tenderer's Name: _____

Date: _____

Tenderer's JV Member Name: _____

Sub-contractor's Name2 (as per ITT 34): _____

ITT No. and title: _____

All Sub-contractors for key activities must complete the information in this form as per ITT 34 and Section III, Evaluation and Qualification Criteria, Sub-Factor 4.2.

1. Key Activity No One: _

Information				
Contract Identification				
Award date				
Completion date				
Role in Contract	Prime Contractor <input type="checkbox"/>	Member in JV <input type="checkbox"/>	Management Contractor <input type="checkbox"/>	Sub-contractor <input type="checkbox"/>
Total Contract Amount				Kenya Shilling
Quantity (Volume, number or rate of production, as applicable) performed under the contract per year or part of the year	Total quantity in the contract (i)	Percentage participation (ii)		Actual Quantity Performed (i) x (ii)
Year 1				
Year 2				
Year 3				
Year 4				
Procuring Entity's Name:				
Address: Telephone/fax number E-mail:				

2 If applicable

	Information
Description of the key activities in accordance with Sub-Factor 4.2(b) of Section III:	

2. Activity No. Two

3.

OTHER FORMS

5. FORM OF TENDER

INSTRUCTIONS TO TENDERERS

- i) *The Tenderer must prepare this Form of Tender on stationery with its letterhead clearly showing the Tenderer's complete name and business address.*
- ii) *All italicized text is to help Tenderer in preparing this form.*
- iii) *Tenderer must complete and sign CERTIFICATE OF INDEPENDENT TENDER DETERMINATION and the SELF DECLARATION OF THE TENDERER attached to this Form of Tender.*
- iv) *The Form of Tender shall include the following Forms duly completed and signed by the Tenderer.*
 - *Tenderer's Eligibility- Confidential Business Questionnaire*
 - *Certificate of Independent Tender Determination*
 - *Self-Declaration of the Tenderer*

Date of this Tender submission:

Request for Tender No.:

Name and description of Tender.:

Alternative No.:

To:

1. In accordance with the Conditions of Contract, Specifications, Drawings and Bills of Quantities for the execution of the above named Works, we, the undersigned offer to construct and complete the Works and remedy any defects therein for the sum of Kenya Shillings [*Amount in figures*] _____ Kenya Shillings [*amount in words*] _____.

The above amount includes foreign currency amount (s) of [*state figure or a percentage and currency*] [*figures*] _____ [*words*] _____.

The percentage or amount quoted above does not include provisional sums, and only allows not more than two foreign currencies.

2. We undertake, if our tender is accepted, to commence the Works as soon as is reasonably possible after the receipt of the Project Manager's notice to commence, and to complete the whole of the Works comprised in the Contract within the time stated in the Special Conditions of Contract.
3. We agree to adhere by this tender until _____ [*Insert date*], and it shall remain binding upon us and may be accepted at any time before that date.
4. Unless and until a formal Agreement is prepared and executed this tender together with your written acceptance thereof, shall constitute a binding Contract between us. We further understand that you are not bound to accept the lowest or any tender you may receive.
5. We, the undersigned, further declare that:
 - i) No reservations: We have examined and have no reservations to the tender document, including Addenda issued in accordance with ITT 28;
 - ii) Eligibility: We meet the eligibility requirements and have no conflict of interest in accordance with ITT 3 and 4;
 - iii) Tender-Securing Declaration: We have not been suspended nor declared ineligible by the Procuring Entity based on execution of a Tender-Securing or Proposal-Securing Declaration in the Procuring Entity's Country in accordance with ITT 19.8;
 - iv) Conformity: We offer to execute in conformity with the tendering documents and in accordance with the implementation and completion specified in the construction schedule, the following Works: [*insert a brief description of the Works*];

- v) **Tender Price:** The total price of our Tender, excluding any discounts offered in item 1 above is: ___ [Insert one of the options below as appropriate]
- vi) **Option 1**, in case of one lot: Total price is: _____
 [insert the total price of the Tender in words and figures, indicating the various amounts and the respective currencies]; Or

Option 2, in case of multiple lots:

- a) **Total price of each lot** [insert the total price of each lot in words and figures, indicating the various amounts and the respective currencies];
 _____ and
- b) **Total price of all lots** (sum of all lots) [insert the total price of all lots in words and figures, indicating the various amounts and the respective currencies]; _____
- vii) **Discounts:** The discounts offered and the methodology for their application are:
- viii) The discounts offered are: [Specify in detail each discount offered.]
- ix) The exact method of calculations to determine the net price after application of discounts is shown below: [Specify in detail the method that shall be used to apply the discounts];
- x) **Tender Validity Period:** Our Tender shall be valid for the period specified in TDS 18.1 (as amended, if applicable) from the date fixed for the Tender submission deadline specified in TDS 22.1 (as amended, if applicable), and it shall remain binding upon us and may be accepted at any time before the expiration of that period;
- xi) **Performance Security:** If our Tender is accepted, we commit to obtain a Performance Security in accordance with the Tendering document;
- xii) **One Tender Per Tender:** We are not submitting any other Tender(s) as an individual Tender, and we are not participating in any other Tender(s) as a Joint Venture member or as a subcontractor, and meet the requirements of ITT 3.4, other than alternative Tenders submitted in accordance with ITT 13.3;
- xiii) **Suspension and Debarment:** We, along with any of our subcontractors, suppliers, Project Manager, manufacturers, or service providers for any part of the contract, are not subject to, and not controlled by any entity or individual that is subject to, a temporary suspension or a debarment imposed by the Public Procurement Regulatory Authority or any other entity of the Government of Kenya, or any international organization.
- xiv) **State-owned enterprise or institution:** We are not a state-owned enterprise or institution;
- xv) **Commissions, gratuities, fees:** We have paid, or will pay the following commissions, gratuities, or fees with respect to the tender process or execution of the Contract: [insert complete name of each Recipient, its full address, the reason for which each commission or gratuity was paid and the amount and currency of each such commission or gratuity].

Name of Recipient	Address	Reason	Amount

(If none has been paid or is to be paid, indicate "none.")

- xvi) **Binding Contract:** We understand that this Tender, together with your written acceptance thereof included in your Letter of Acceptance, shall constitute a binding contract between us, until a formal contract is prepared and executed;
- xvii) **Not Bound to Accept:** We understand that you are not bound to accept the lowest evaluated cost Tender, the Most Advantageous Tender or any other Tender that you may receive;
- xviii) **Fraud and Corruption:** We hereby certify that we have taken steps to ensure that no person acting for us or on our behalf engages in any type of Fraud and Corruption;

- xix) Collusive practices: We hereby certify and confirm that the tender is genuine, non-collusive and made with the intention of accepting the contract if awarded. To this effect we have signed the “Certificate of Independent Tender Determination” attached below.
- xx) We undertake to adhere by the Code of Ethics for Persons Participating in Public Procurement and Asset Disposal, copy available from _____ (*specify website*) during the procurement process and the execution of any resulting contract.
- xxi) We, the Tenderer, have completed fully and signed the following Forms as part of our Tender:
- a) Tenderer’s Eligibility; Confidential Business Questionnaire – to establish we are not in any conflict of interest.
 - b) Certificate of Independent Tender Determination – to declare that we completed the tender without colluding with other tenderers.
 - c) Self-Declaration of the Tenderer – to declare that we will, if awarded a contract, not engage in any form of fraud and corruption.
 - d) Declaration and commitment to the Code of Ethics for Persons Participating in Public Procurement and Asset Disposal

Further, we confirm that we have read and understood the full content and scope of fraud and corruption as informed in “**Appendix 1- Fraud and Corruption**” attached to the Form of Tender.

Name of the Tenderer: * _____ [*insert complete name of person signing the Tender*]

Name of the person duly authorized to sign the Tender on behalf of the Tenderer:

** _____ [*insert complete name of person duly authorized to sign the Tender*]

Title of the person signing the Tender: _____ [*insert complete title of the person signing the Tender*]

Signature of the person named above: _____ [*insert signature of person whose name and capacity are shown above*] **Date signed** _____ [*insert date of signing*] day of [*insert month*], [*insert year*]

Date signed _____ **day of** _____, _____

Notes

* *In the case of the Tender submitted by joint venture specify the name of the Joint Venture as Tenderer*

** *Person signing the Tender shall have the power of attorney given by the Tenderer to be attached with the Tender.*

A. TENDERER'S ELIGIBILITY- CONFIDENTIALBUSINESS QUESTIONNAIRE

Instruction to Tenderer

Tender is instructed to complete the particulars required in this Form, *one form for each entity if Tender is a JV.* Tenderer is further reminded that it is an offence to give false information on this Form.

(a) Tenderer's details

	ITEM	DESCRIPTION
1	Name of the Procuring Entity	
2	Reference Number of the Tender	
3	Date and Time of Tender Opening	
4	Name of the Tenderer	
5	Full Address and Contact Details of the Tenderer.	1. Country 2. City 3. Location 4. Building 5. Floor 6. Postal Address 7. Name and email of contact person.
6	Current Trade License Registration Number and Expiring date	
7	Name, country and full address (<i>postal and physical addresses, email, and telephone number</i>) of Registering Body/Agency	
8	Description of Nature of Business	
9	Maximum value of business which the Tenderer handles.	
10	State if Tenders Company is listed in stock exchange, give name and full address (<i>postal and physical addresses, email, and telephone number</i>) of state which stock exchange	

General and Specific Details

b) **Sole Proprietor**, provide the following details.

Name in full _____ Age _____ Nationality _____
 _____ Country of Origin _____ Citizenship _____

c) **Partnership**, provide the following details.

	Names of Partners	Nationality	Citizenship	% Shares owned
1				
2				
3				

d) **Registered Company**, provide the following details.

i) Private or public Company _____

ii) State the nominal and issued capital of the Company _____

Nominal Kenya Shillings (Equivalent) Issued

Kenya Shillings (Equivalent).....

iii) Give details of Directors as follows.

	Names of Director	Nationality	Citizenship	% Shares owned
1				
2				
3				

(e) **DISCLOSURE OF INTEREST- Interest of the Firm in the Procuring Entity.**

i) Are there any person/persons in (Name of Procuring Entity) who has/have an interest or relationship in this firm? Yes/No.....

If yes, provide details as follows.

	Names of Person	Designation in the Procuring Entity	Interest or Relationship with Tenderer
1			
2			
3			

ii) **Conflict of interest disclosure**

	Type of Conflict	Disclosure YES OR NO	If YES provide details of the relationship with Tenderer
1	Tenderer is directly or indirectly controls, is controlled by or is under common control with another tenderer.		
2	Tenderer receives or has received any direct or indirect subsidy from another tenderer.		
3	Tenderer has the same legal representative as another tenderer		
4	Tender has a relationship with another tenderer, directly or through common third parties, that puts it in a position to influence the tender of another tenderer, or influence the decisions of the Procuring Entity regarding this tendering process.		
5	Any of the Tenderer's affiliates participated as a consultant in		

	Type of Conflict	Disclosure YES OR NO	If YES provide details of the relationship with Tenderer
	the preparation of the design or technical specifications of the works that are the subject of the tender.		
6	Tenderer would be providing goods, works, non-consulting services or consulting services during implementation of the contract specified in this Tender Document.		
7	Tenderer has a close business or family relationship with a professional staff of the Procuring Entity who are directly or indirectly involved in the preparation of the Tender document or specifications of the Contract, and/or the Tender evaluation process of such contract.		
8	Tenderer has a close business or family relationship with a professional staff of the Procuring Entity who would be involved in the implementation or supervision of the such Contract.		
9	Has the conflict stemming from such relationship stated in item 7 and 8 above been resolved in a manner acceptable to the Procuring Entity throughout the tendering process and execution of the Contract.		

f) Certification

On behalf of the Tenderer, I certify that the information given above is complete, current and accurate as at the date of submission.

Full Name _____ Title or

Designation _____

(Signature)

(Date)

B. CERTIFICATE OF INDEPENDENT TENDER DETERMINATION

I, the undersigned, in submitting the accompanying Letter of Tender to the _____ [Name of Procuring Entity] for: _____ [Name and number of tender] in response to the request for tenders made by: _____ [Name of Tenderer] do hereby make the following statements that I certify to be true and complete in every respect:

I certify, on behalf of _____ [Name of Tenderer] that:

1. I have read and I understand the contents of this Certificate;
2. I understand that the Tender will be disqualified if this Certificate is found not to be true and complete in every respect;
3. I am the authorized representative of the Tenderer with authority to sign this Certificate, and to submit the Tender on behalf of the Tenderer;
4. For the purposes of this Certificate and the Tender, I understand that the word "competitor" shall include any individual or organization, other than the Tenderer, whether or not affiliated with the Tenderer, who:
 - a) has been requested to submit a Tender in response to this request for tenders;
 - b) could potentially submit a tender in response to this request for tenders, based on their qualifications, abilities or experience;
5. The Tenderer discloses that [check one of the following, as applicable]:
 - a) The Tenderer has arrived at the Tender independently from, and without consultation, communication, agreement or arrangement with, any competitor;
 - b) the Tenderer has entered into consultations, communications, agreements or arrangements with one or more competitors regarding this request for tenders, and the Tenderer discloses, in the attached document(s), complete details thereof, including the names of the competitors and the nature of, and reasons for, such consultations, communications, agreements or arrangements;
6. In particular, without limiting the generality of paragraphs (5)(a) or (5)(b) above, there has been no consultation, communication, agreement or arrangement with any competitor regarding:
 - a) prices;
 - b) methods, factors or formulas used to calculate prices;
 - c) the intention or decision to submit, or not to submit, a tender; or
 - d) the submission of a tender which does not meet the specifications of the request for Tenders; except as specifically disclosed pursuant to paragraph (5)(b) above;
7. In addition, there has been no consultation, communication, agreement or arrangement with any competitor regarding the quality, quantity, specifications or delivery particulars of the works or services to which this request for tenders relates, except as specifically authorized by the procuring authority or as specifically disclosed pursuant to paragraph (5)(b) above;
8. the terms of the Tender have not been, and will not be, knowingly disclosed by the Tenderer, directly or indirectly, to any competitor, prior to the date and time of the official tender opening, or of the awarding of the Contract, whichever comes first, unless otherwise required by law or as specifically disclosed pursuant to paragraph (5)(b) above.

Name _____ Title _____ Date _____

[Name, title and signature of authorized agent of Tenderer and Date].

C. SELF - DECLARATION FORMS

FORM SD1

SELF DECLARATION THAT THE PERSON/TENDERER IS NOT DEBARRED IN THE MATTER OF THE PUBLIC PROCUREMENT AND ASSET DISPOSAL ACT 2015.

I,, of Post Office Box being a resident of in the Republic of do hereby make a statement as follows: -

1. THAT I am the Company Secretary/ Chief Executive/Managing Director/Principal Officer/Director of(insert name of the Company) who is a Bidder in respect of Tender No. for (insert tender title/description) for (insert name of the Procuring entity) and duly authorized and competent to make this statement.
2. THAT the aforesaid Bidder, its Directors and subcontractors have not been debarred from participating in procurement proceeding under Part IV of the Act.
3. THAT what is deponed to herein above is true to the best of my knowledge, information and belief.

..... (Title)
(Signature) (Date)

Bidder Official Stamp

FORM SD2

SELF DECLARATION THAT THE PERSON/TENDERER WILL NOT ENGAGE IN ANY CORRUPT OR FRAUDULENT PRACTICE

I, of P. O. Box being a resident of in the Republic of do hereby make a statement as follows: -

1. THAT I am the Chief Executive/Managing Director/Principal Officer/Director of (*insert name of the Company*) who is a Bidder in respect of Tender No for (*insert tender title/description*) for (*insert name of the Procuring entity*) and duly authorized and competent to makethis statement.
2. THAT the aforesaid Bidder, its servants and/or agents /subcontractors will not engage in any corrupt or fraudulent practice and has not been requested to pay any inducement to any member of the Board, Management, Staff and/or employees and/or agents of(*insert name of the Procuring entity*) which is the procuring entity.
3. THAT the aforesaid Bidder, its servants and/or agents /subcontractors have not offered any inducement to any member of the Board, Management, Staff and/or employees and/or agents of(name of the procuring entity)
4. THAT the aforesaid Bidder will not engage /has not engaged in any corrosive practice with other bidders participating in thesubject tender
5. THAT what is deponed to herein above is true to thebest of my knowledge information and belief.

.....
(Title)

.....
(Signature)

.....
(Date)

Bidder's Official Stamp

DECLARATION AND COMMITMENT TO THE CODE OF ETHICS

I (person) on behalf of (*Name of the Business/ Company/Firm*).....declare that I have read and fully understood the contents of the Public Procurement & Asset Disposal Act, 2015, Regulations and the Code of Ethics for persons participating in Public Procurement and Asset Disposal and my responsibilities under the Code.

I do hereby commit to abide by the provisions of the Code of Ethics for persons participating in Public Procurement and Asset Disposal.

Name of Authorized signatory..... Sign.....

Position.....

Office address..... Telephone.....

E-mail.....

Name of the Firm/Company.....

Date.....(Company Seal/ Rubber

Stamp where applicable)

Witness

Name Sign.....

Date.....

D. APPENDIX 1- FRAUD AND CORRUPTION

(Appendix 1 shall not be modified)

1. Purpose

2. The Government of Kenya's Anti-Corruption and Economic Crime laws and their sanction's policies and procedures, Public Procurement and Asset Disposal Act (*no. 33 of 2015*) and its Regulation, and any other Kenya's Acts or Regulations related to Fraud and Corruption, and similar offences, shall apply with respect to Public Procurement Processes and Contracts that are governed by the laws of Kenya.

3. Requirements

The Government of Kenya requires that all parties including Procuring Entities, Tenderers, (applicants/proposers), Consultants, Contractors and Suppliers; any Sub-contractors, Sub-consultants, Service providers or Suppliers; any Agents (whether declared or not); and any of their Personnel, involved and engaged in procurement under Kenya's Laws and Regulation, observe the highest standard of ethics during the procurement process, selection and contract execution of all contracts, and refrain from Fraud and Corruption and fully comply with Kenya's laws and Regulations as per paragraphs 1.1 above.

Kenya's public procurement and asset disposal act (*no. 33 of 2015*) under Section 66 describes rules to be followed and actions to be taken in dealing with Corrupt, Coercive, Obstructive, Collusive or Fraudulent practices, and Conflicts of Interest in procurement including consequences for offences committed. A few of the provisions noted below highlight Kenya's policy of no tolerance for such practices and behavior: -

- 1) a person to whom this Act applies shall not be involved in any corrupt, coercive, obstructive, collusive or fraudulent practice; or conflicts of interest in any procurement or asset disposal proceeding;
- 2) A person referred to under subsection (1) who contravenes the provisions of that sub-section commits an offence;
- 3) Without limiting the generality of the subsection (1) and (2), the person shall be: -
 - a) disqualified from entering into a contract for a procurement or asset disposal proceeding; or
 - b) if a contract has already been entered into with the person, the contract shall be voidable;
- 4) The voiding of a contract by the procuring entity under subsection (7) does not limit any legal remedy the procuring entity may have;
- 5) An employee or agent of the procuring entity or a member of the Board or committee of the procuring entity who has a conflict of interest with respect to a procurement: -
 - a) shall not take part in the procurement proceedings;
 - b) shall not, after a procurement contract has been entered into, take part in any decision relating to the procurement or contract; and
- c) shall not be a subcontractor for the bidder to whom was awarded contract, or a member of the group of bidders to whom the contract was awarded, but the subcontractor appointed shall meet all the requirements of this Act.
- 6) An employee, agent or member described in subsection (1) who refrains from doing anything prohibited under that subsection, but for that subsection, would have been within his or her duties shall disclose the conflict of interest to the procuring entity;
- 7) If a person contravenes subsection (1) with respect to a conflict of interest described in subsection (5)(a) and the contract is awarded to the person or his relative or to another person in whom one of them had a direct or indirect pecuniary interest, the contract shall be terminated and all costs incurred by the public entity shall be made good by the awarding officer. Etc.

In compliance with Kenya's laws, regulations and policies mentioned above, the Procuring Entity:

- a) Defines broadly, for the purposes of the above provisions, the terms set forth below as follows:
 - i) "corrupt practice" is the offering, giving, receiving, or soliciting, directly or indirectly, of anything of value to influence improperly the actions of another party;
 - ii) "fraudulent practice" is any act or omission, including misrepresentation, that knowingly or recklessly misleads, or attempts to mislead, a party to obtain financial or other benefit or to avoid an

obligation;

- iii) “collusive practice” is an arrangement between two or more parties designed to achieve an improper purpose, including to influence improperly the actions of another party;
- iv) “coercive practice” is impairing or harming, or threatening to impair or harm, directly or indirectly, any party or the property of the party to influence improperly the actions of a party;
- v) “obstructive practice” is:
 - deliberately destroying, falsifying, altering, or concealing of evidence material to the investigation or making false statements to investigators in order to materially impede investigation by Public Procurement Regulatory Authority (PPRA) or any other appropriate authority appointed by Government of Kenya into allegations of a corrupt, fraudulent, coercive, or collusive practice; and/or threatening, harassing, or intimidating any party to prevent it from disclosing its knowledge of matters relevant to the investigation or from pursuing the investigation; or
 - acts intended to materially impede the exercise of the PPRA's or the appointed authority's inspection and audit rights provided for under paragraph 2.3 e. below.
- b) Defines more specifically, in accordance with the above procurement Act provisions set forth for fraudulent and collusive practices as follows:

"fraudulent practice" includes a misrepresentation of fact in order to influence a procurement or disposal process or the exercise of a contract to the detriment of the procuring entity or the tenderer or the contractor, and includes collusive practices amongst tenderers prior to or after tender submission designed to establish tender prices at artificial non-competitive levels and to deprive the procuring entity of the benefits of free and open competition.
- c) Rejects a proposal for award¹ of a contract if PPRA determines that the firm or individual recommended for award, any of its personnel, or its agents, or its sub-consultants, sub-contractors, service providers, suppliers and/ or their employees, has, directly or indirectly, engaged in corrupt, fraudulent, collusive, coercive, or obstructive practices in competing for the contract in question;
- d) Pursuant to the Kenya's above stated Acts and Regulations, may sanction or recommend to appropriate authority (ies) for sanctioning and debarment of a firm or individual, as applicable under the Acts and Regulations;
- e) Requires that a clause be included in Tender documents and Request for Proposal documents requiring (i) Tenderers (applicants/proposers), Consultants, Contractors, and Suppliers, and their Sub-contractors, Sub-consultants, Service providers, Suppliers, Agents personnel, permit the PPRA or any other appropriate authority appointed by Government of Kenya to inspect² all accounts, records and other documents relating to the procurement process, selection and/or contract execution, and to have them audited by auditors appointed by the PPRA or any other appropriate authority appointed by Government of Kenya; and
- f) Pursuant to Section 62 of the above Act, requires Applicants/Tenderers to submit along with their Applications/Tenders/Proposals a “Self-Declaration Form” as included in the procurement document declaring that they and all parties involved in the procurement process and contract execution have not engaged/will not engage in any corrupt or fraudulent practices.

¹For the avoidance of doubt, a party's ineligibility to be awarded a contract shall include, without limitation, (i) applying for pre-qualification, expressing interest in a consultancy, and tendering, either directly or as a nominated sub-contractor, nominated consultant, nominated manufacturer or supplier, or nominated service provider, in respect of such contract, and (ii) entering into an addendum or amendment introducing a material modification to any existing contract.

² Inspections in this context usually are investigative (i.e., forensic) in nature. They involve fact-finding activities undertaken by the Investigating Authority or persons appointed by the Procuring Entity to address specific matters related to investigations/audits, such as evaluating the veracity of an allegation of possible Fraud and Corruption, through the appropriate mechanisms. Such activity includes but is not limited to: accessing and examining a firm's or individual's financial records and information, and making copies thereof as relevant; accessing and examining any other documents, data and information (whether in hard copy or electronic format) deemed relevant for the investigation/audit, and making copies thereof as relevant; interviewing staff and other relevant individuals; performing physical inspections and site visits; and obtaining third party verification of information.

FORM OF TENDER SECURITY-[Option 1–Demand Bank Guarantee]

Beneficiary: _____

Request for Tenders No: _____

Date: _____

TENDER GUARANTEE No.: _____

Guarantor: _____

1. We have been informed that _____ (here inafter called "the Applicant") has submitted or will submit to the Beneficiary its Tender (here inafter called" the Tender") for the execution of _____ under Request for Tenders No. _____ ("the ITT").
2. Furthermore, we understand that, according to the Beneficiary's conditions, Tenders must be supported by a Tender guarantee.
3. At the request of the Applicant, we, as Guarantor, hereby irrevocably undertake to pay the Beneficiary any sum or sums not exceeding in total an amount of _____ (_____) upon receipt by us of the Beneficiary's complying demand, supported by the Beneficiary's statement, whether in the demand itself or a separate signed document accompanying or identifying the demand, stating that either the Applicant:
 - (a) has withdrawn its Tender during the period of Tender validity set forth in the Applicant's Letter of Tender ("the Tender Validity Period"), or any extension thereto provided by the Applicant; or
 - b) having been notified of the acceptance of its Tender by the Beneficiary during the Tender Validity Period or any extension there to provided by the Applicant, (i) has failed to execute the contract agreement, or (ii) has failed to furnish the Performance.
4. This guarantee will expire: (a) if the Applicant is the successful Tenderer, upon our receipt of copies of the contract agreement signed by the Applicant and the Performance Security and, or (b) if the Applicant is not the successful Tenderer, upon the earlier of (i) our receipt of a copy of the Beneficiary's notification to the Applicant of the results of the Tendering process; or (ii) thirty days after the end of the Tender Validity Period.
5. Consequently, any demand for payment under this guarantee must be received by us at the office indicated above onor before that date.

[signature(s)]

Note: All italicized text is for use in preparing this form and shall be deleted from the final product.

FORMAT OF TENDER SECURITY [Option 2–Insurance Guarantee]

TENDER GUARANTEE No.: _____

1. Whereas (hereinafter called “the tenderer”) has submitted its tender dated for the (hereinafter called “the Tender”) for the execution of _____ under Request for Tenders No. _____ (“the ITT”).
2. KNOW ALL PEOPLE by these presents that WE of having our registered office at (hereinafter called “the Guarantor”), are bound unto (hereinafter called “the Procuring Entity”) in the sum of (Currency and guarantee amount) for which payment well and truly to be made to the said Procuring Entity, the Guarantor binds itself, its successors and assigns, jointly and severally, firmly by these presents.

Sealed with the Common Seal of the said Guarantor this ____ day of _____ 20 ____.

3. NOW, THEREFORE, THE CONDITION OF THIS OBLIGATION is such that if the Applicant:
 - a) has withdrawn its Tender during the period of Tender validity set forth in the Principal's Letter of Tender (“the Tender Validity Period”), or any extension thereto provided by the Principal; or
 - b) having been notified of the acceptance of its Tender by the Procuring Entity during the Tender Validity Period or any extension thereto provided by the Principal; (i) failed to execute the Contract agreement; or (ii) has failed to furnish the Performance Security, in accordance with the Instructions to tenderers (“ITT”) of the Procuring Entity's Tendering document.

then the guarantee undertakes to immediately pay to the Procuring Entity up to the above amount upon receipt of the Procuring Entity's first written demand, without the Procuring Entity having to substantiate its demand, provided that in its demand the Procuring Entity shall state that the demand arises from the occurrence of any of the above events, specifying which event(s) has occurred.

4. This guarantee will expire: (a) if the Applicant is the successful Tenderer, upon our receipt of copies of the contract agreement signed by the Applicant and the Performance Security and, or (b) if the Applicant is not the successful Tenderer, upon the earlier of (i) our receipt of a copy of the Beneficiary's notification to the Applicant of the results of the Tendering process; or (ii) twenty-eight days after the end of the Tender Validity Period.
5. Consequently, any demand for payment under this guarantee must be received by us at the office indicated above on or before that date.

[Date]

[Signature of the Guarantor]

[Witness]

[Seal]

Note: All italicized text is for use in preparing this form and shall be deleted from the final product.

TENDER-SECURING DECLARATION FORM

Date:.....

Tender

No.:.....

To:..... I/We, theundersigned, declare that:

- 1. I/Weunderstand that, according to your conditions, bids must besupported by a Tender-Securing Declaration.
- 2. I/We accept that I/we will automatically be suspended from being eligible for tendering in any contract with the Purchaser for theperiod of time of [insert number of months or years] starting on [insert date], if we are in breach of our obligation(s) under the bid conditions, because we – (a) have withdrawn our tender during the period of tender validity specified by us in the Tendering Data Sheet; or (b) having been notified of the acceptance of our Bid by the Purchaser during the period of bid validity, (i) fail or refuse to execute the Contract, if required, or (ii) fail or refuse to furnish the Performance Security, in accordance with the instructions to tenders.
- 3. I/We understand that this Tender Securing Declaration shall expire if we are not the successful Tenderer(s), upon the earlier of:
 - a) our receipt of a copy of your notification of the name of the successful Tenderer; or
 - b) thirty days after the expiration of our Tender.
- 4. I/We understand that if I am/we are/in a Joint Venture, the Tender Securing Declaration must be in the name of the Joint Venture that submits the bid, and the Joint Venture has not been legally constituted at the time of bidding, the Tender Securing Declaration shall bein the names of all future partners as named in the letter of intent.

Signed..... Capacity / title (director
or partner or sole proprietor, etc.) Name:

..... Duly authorized to sign the bid
for and on behalf of:

Dated on day ofSeal or stamp

Appendix to Tender

Schedule of Currency requirements

Summary of currencies of the Tender for _____

<i>Name of currency</i>	<i>Amounts payable</i>
Local currency: _____	
Foreign currency #1: _____	
Foreign currency #2: _____	
Foreign currency #3: _____	
Provisional sums expressed in local currency	[To be entered by the Procuring Entity]

PART II - WORK REQUIREMENTS

SECTION VI - SPECIFICATIONS

Notes for preparing Specifications

1. Specifications must be drafted to present a clear and precise statement of the required standards of materials, and workmanship for tenderers to respond realistically and competitively to the requirements of the Procuring Entity and ensure responsiveness of tenders. The Specifications should require that all materials, plant, and other supplies to be permanently incorporated in the Works be new, unused, of the most recent or current models, and incorporating all recent improvements in design and materials unless provided otherwise in the Contract. Where the Contractor is responsible for the design of any part of the permanent Works, the extent of his obligations must be stated.
2. Specifications from previous similar projects are useful and may not be necessary to re-write specifications for every Works Contract.
3. There are considerable advantages in standardizing **General Specifications** for repetitive Works in recognized public sectors, such as highways, urban housing, irrigation and water supply. The General Specifications should cover all classes of workmanship, materials and equipment commonly involved in constructions, although not necessarily to be used in a particular works contract. Deletions or addenda should then adapt the General Specifications to the particular Works.
4. Care must be taken in drafting Specifications to ensure they are not restrictive. In the Specifications of standards for materials, plant and workmanship, existing Kenya Standards should be used as much as possible, otherwise recognized international standards may also be used.
5. The Procuring Entity should decide whether technical solutions to specified parts of the Works are to be permitted. Alternatives are appropriate in cases where obvious (and potentially less costly) alternatives are possible to the technical solutions indicated in tender documents for certain elements of the Works, taking into consideration the comparative specialized advantage of potential tenderers.
6. The Procuring Entity should provide a description of the selected parts of the Works with appropriate reference to Drawings, Specifications, Bills of Quantities, and Design or Performance criteria, stating that the alternative solutions shall be at least structurally and functionally equivalent to the basic design parameters and Specifications.
 1. Such alternative solutions shall be accompanied by all information necessary for a complete evaluation by the Procuring Entity, including drawings, design calculations, technical specifications, breakdown of prices, proposed construction methodology, and other relevant details. Technical alternatives permitted in this manner shall be considered by the Procuring Entity each on its own merits and independently of whether the tenderer has priced the items described in the Procuring Entity's design included with the tender documents.

SECTION VII- BILLS OF QUANTITIES

1. Objectives

The objectives of the Bill of Quantities are:

- a) to provide sufficient information on the quantities of Works to be performed to enable tenders to be prepared efficiently and accurately; and
- b) when a Contract has been entered into, to provide a priced Bill of Quantities for use in the periodic valuation of Works executed.

In order to attain these objectives, Works should be itemized in the Bill of Quantities in sufficient detail to distinguish between the different classes of Works, or between Works of the same nature carried out in different locations or in other circumstances which may give rise to different considerations of cost. Consistent with these requirements, the layout and contents of the Bill of Quantities should be as simple and brief as possible.

2. Day work Schedule

A Day work Schedule should be included only if the probability of unforeseen work, outside the items included in the Bill of Quantities, is high. To facilitate checking by the Procuring Entity of the realism of rates quoted by the Tenderers, the Day work Schedule should normally comprise the following:

- a) A list of the various classes of labor, materials, and Constructional Plant for which basic day work rates or prices are to be inserted by the Tenderer, together with a statement of the conditions under which the Contractor shall be paid for work executed on a day work basis.
- b) Nominal quantities for each item of day work, to be priced by each Tenderer at day work rates as Tender. The rate to be entered by the Tenderer against each basic day work item should include the Contractor's profit, overheads, supervision, and other charges.

3. Provisional Sums

A general provision for physical contingencies (quantity overruns) may be made by including a provisional sum in the Summary Bill of Quantities. Similarly, a contingency allowance for possible price increases should be provided as a provisional sum in the Summary priced Bill of Quantities. The inclusion of such provisional sums often facilitates budgetary approval by avoiding the need to request periodic supplementary approvals as the future need arises. Where such provisional sums or contingency allowances are used, the Special Conditions of Contract should state the manner in which they shall be used, and under whose authority (usually the Project Manager's).

The estimated cost of specialized work to be carried out, or of special goods to be supplied, by other contractors should be indicated in the relevant part of the Bill of Quantities as a particular provisional sum with an appropriate brief description. A separate procurement procedure is normally carried out by the Procuring Entity to select such specialized contractors. To provide an element of competition among the Tenderers in respect of any facilities, amenities, attendance, etc., to be provided by the successful Tenderer as prime Contractor for the use and convenience of the specialist contractors, each related provisional sum should be followed by an item in the Bill of Quantities inviting the Tenderer to quote a sum for such amenities, facilities, attendance, etc.

These Notes for Preparing a Bill of Quantities are intended only as information for the Procuring Entity or the person drafting the tendering document. They should not be included in the final tendering document.

4. The Bills of Quantities

The Bills of Quantities should be divided generally into the following sections:

- a) Preambles
- b) Preliminary items
- c) Work Items
- c) Daywork Schedule; and
- d) Provisional items
- e) Summary.

**PROPOSED CONSTRUCTION OF
CLIMATE CHANGE INFORMATION
CENTRE OFFICE DEVELOPMENT IN
SOKONI WARD - KILIFI
MUNICIPALITY**

PARTICULAR PRELIMINARIES

PROPOSED CONSTRUCTION OF CLIMATE CHANGE INFORMATION CENTRE OFFICE
DEVELOPMENT IN SOKONI WARD - KILIFI MUNICIPALITY

ITEM	DESCRIPTION	AMOUNT
	<u>PARTICULAR PRELIMINARIES</u>	
A	<p>PRICING ITEMS OF PRELIMINARIES Prices SHALL BE INSERTED against items of “preliminaries” in the tenderer’s priced Bills of Quantities. The contractor is advised to read and understand all preliminary items.</p>	
B	<p>DESCRIPTION OF THE WORKS The works to be carried out under this contract involves; Erection and completion of a 2 storey Office Block which involve; substructures, concrete structure, coral stone walling, roof structure and roofing, doors, windows, external and internal finishes, associated mechanical and electrical services and external works (septic tank, and soakpit)</p>	
C	<p>FLOOR AREAS The total gross floor areas are approximately 1300 square metres. The total gross floor area is given without warranty but for guidance only.</p>	
D	<p>MEASUREMENTS In the event of any discrepancies arising between the Bills of Quantities and the actual works, the site measurements shall generally take precedence. However, such discrepancies between any contract documents shall immediately be referred to the PROJECT MANAGER in accordance with Clause 22 of the Conditions of Contract. The discrepancies shall then be treated as a variation and be dealt with in accordance with Clause 22 of the said Conditions.</p>	
E	<p>LOCATION OF SITE The site of the proposed works is located at Sokoni Ward - Kilifi Municipality, Kilifi County. The Contractor is advised to visit the site, to familiarize with the nature and position of the site. No claims arising from the Contractor’s failure to do so will be entertained. The Contractor shall be deemed to have verified for themselves following:- (a) The nature of the site (b) The amount of clearing and cutting and fillings and therefore ready with the right equipment. (c) The nature of existing communication by road or otherwise. (d) The availability of land for the erection and positioning of all temporary structures, plant and materials necessary for the execution of the works. (e) Underground surfacewater conditions</p>	
F	<p>SIGNING OF THE TENDER DOCUMENTS The bidder shall append his / her signature and / or company’s rubberstamp on each and every page of tender document.</p>	
	Carried to collection	

PROPOSED CONSTRUCTION OF CLIMATE CHANGE INFORMATION CENTRE OFFICE
DEVELOPMENT IN SOKONI WARD - KILIFI MUNICIPALITY

ITEM	DESCRIPTION	AMOUNT
A	<p>DEMOLITIONS AND ALTERATIONS</p> <p>The Contractor is to allow for all temporary protection required during the works including ordinary and special dust screens, hoardings, barriers, warning signs, etc as directed by the Project Manager and</p> <p>as necessary for the adequate propping and protection of existing property, finishes, workmen employed on the site, employer's agents and the public. Any damage or loss incurred due to the insufficiency of such protection must be made good by the Contractor. All protective devices are to be removed on completion of the works and any necessary making good consequent upon this is to be executed to the satisfaction of the Project Manager</p> <p>The works shall be propped, strutted and supported as necessary before any alteration or demolition work commences. Prices shall include for all cleaning and preparatory work to structure and finishes and for making good to all finishes on completion whether or not specifically described.</p> <p>Unless described as set aside for re-use all arising debris and surplus materials shall be carefully removed from building and carted away from site.</p> <p>The Contractor shall be entirely responsible for any breakage or damage which may occur to materials required for re-use during their removal unless it is certified by the Project Manager that such damage or breakage was inevitable as a result of the condition of the item concerned</p>	
B	<p>CLEARING AWAY</p> <p>The Contractor shall remove all temporary works, rubbish, debris and surplus materials from the site as they accumulate and upon completion of the works, remove and clear away all plant, equipment, rubbish, unused materials and stains and leave in a clean and tidy state to the reasonable satisfaction of the Project Manager.</p> <p>The whole of the works shall be delivered up clean, complete and in perfect condition in every respect to the satisfaction of the Project Manager.</p>	
C	<p>CLAIMS</p> <p>It shall be a condition of this contract that upon it becoming reasonably apparent to the Contractor that he has incurred losses and / or expenses due to any of the contract conditions, or by any other reason whatsoever, he shall present such a claim or intent to claim notice to the PROJECT MANAGER within the contract period. No claim shall be entertained upon the expiry of the said contact period.</p>	
	Carried to collection	

PROPOSED CONSTRUCTION OF CLIMATE CHANGE INFORMATION CENTRE OFFICE
DEVELOPMENT IN SOKONI WARD - KILIFI MUNICIPALITY

ITEM	DESCRIPTION	AMOUNT
A	<p>PAYMENTS</p> <p>The tenderer's attention is drawn to the fact that the GOVERNMENT DOES NOT MAKE ADVANCE PAYMENTS but pays for work done and materials delivered to sit: all in accordance with Clause 23 of the Conditions of Contract Agreement. In order to facilitate this, a list of the general component elements for the works is given at the summary page of these specifications and the tenderer is requested to break down his tender sum commensurate to the said elements</p>	
B	<p>PREVENTION OF ACCIDENT, DAMAGE OR LOSS</p> <p>The Contractor is notified that these works are to be carried out on a restricted site where the client is going on with other normal activities. The Contractor is thus instructed to take reasonable care in the execution of the works as to prevent accidents, damage or loss and disruption of activities being carried out by the Client. The Contractor shall allow in his rates any expense he deemed necessary by taking such care within the site.</p>	
C	<p>WORKING CONDITIONS</p> <p>The Contractor shall allow in his rates for any interference that he may encounter in the course of the works for the Client may in some cases ask the Contractor not to proceed with the works until some activities within the site are completed, as the facility will be operating as usual during the course of the contract.</p>	
D	<p>SIGNBOARD</p> <p>Allow for providing, erecting, maintaining throughout the course of the Contract and afterwards clearing away a signboard as designed, specified and approved by the Project Manager.</p>	
E	<p>LABOUR CAMPS</p> <p>The Contractor shall not be allowed to house labour on site. Allow for transporting workers to and from the site during the tenure of the contract.</p>	
F	<p>MATERIALS FROM DEMOLITIONS</p> <p>Any materials arising from demolitions and not re-used shall become the property of St. Thomas Girls Secondary School. The Contractor shall allow in his rates the cost of transporting the demolished materials as directed.</p>	
	Carried to collection	

PROPOSED CONSTRUCTION OF CLIMATE CHANGE INFORMATION CENTRE OFFICE
DEVELOPMENT IN SOKONI WARD - KILIFI MUNICIPALITY

ITEM	DESCRIPTION	AMOUNT
A	<p>PRICING RATES</p> <p>The tenderer shall include for all costs in executing the whole of the works, including transport, replacing damaged items, fixing, all to comply with the said Conditions of Contract.</p>	
B	<p>SECURITY</p> <p>The Contractor shall allow for providing adequate security for the works and the workers in the course of execution of this contract. No claim will be entertained from the Contractor for not maintaining adequate security for both the works and workers.</p>	
C	<p>URGENCY OF THE WORKS</p> <p>The Contractor is notified that these “ works are urgent” and should be completed within the period stated in these Particular Preliminaries.</p> <p>The Contractor shall allow in his rates for any costs he/ she deems that he/she may incur by having to complete these works within the stipulated contract period.</p>	
D	<p>PAYMENT FOR MATERIALS ON SITE</p> <p>All materials for incorporation in the works must be stored on site before payment is effected, unless specifically exempted by the Project Manager. This is to include materials of the Contractor, nominated sub-Contractors and nominated suppliers.</p>	
E	<p>EXISTING SERVICES</p> <p>Prior to the commencement of any work, the Contractor is to ascertain from the relevant authority the exact position, depth and level of all existing services in the area and he/she shall make whatever provisions may be required by the authorities concerned for the support, maintenance and protection of such services.</p>	
F	<p>CONTRACT COMPLETION PERIOD</p> <p>The contract completion period in accordance with condition 31 of the Conditions of contract must be adhered to.</p> <p>The ‘PROJECT MANAGER’ shall strictly monitor the Contractors progress in relation to the progress chart and should it be found necessary the ‘PROJECT MANAGER’ shall inform the Contractor in writing that his actual performance on site is not satisfactory .In all such cases the Contractor shall accelerate his rate of performance production and progress by all means such as additional labour,plant, e.t.c and working overtime all at his cost.</p>	
	Carried to collection	

PROPOSED CONSTRUCTION OF CLIMATE CHANGE INFORMATION CENTRE OFFICE
DEVELOPMENT IN SOKONI WARD - KILIFI MUNICIPALITY

ITEM	DESCRIPTION	AMOUNT
A	<p>PERFORMANCE BOND</p> <p>A bond of 5% of the contract sum will be required in accordance with clause 6.00 (as amended) on award of contract of the Instructions to Tenderer's. No payment on account for the works executed will be made to the contractor until he has submitted the Performance Bond to the Project Manager duly signed, sealed and stamped from an approved Bank.</p>	
B	<p>TENDER DOCUMENTS</p> <p>Tender documents are as listed in Clause 2.1 of the Instruction to Tenderer's Page STD/8</p>	
C	<p>DELIVERY OF TENDER</p> <p>Tenders and all documents in connection therewith, as specified above must be delivered in the addressed envelope which should be properly sealed and deposited at the offices as specified in the letter accompanying these documents or as indicated in the advertisement.</p> <p>Tenders will be opened at the time specified in the letter accompanying these Tender Documents or as indicated in the advertisement. Tenders delivered/received later than the above time will not be opened.</p>	
D	<p>VALUE ADDED TAX</p> <p>The Contractor's attention is drawn to the Legal Notice in the Finance Act part 3 Section 21(b) operative from 1st September, 1993 which requires payment of VAT on all contracts. The Contractor should therefore include allowance in his rates and prices for prices for VAT and any other Government taxes currently in force.</p> <p>NB: VAT shall be added at the Grand Summary page</p>	
	Carried to collection	

PROPOSED CONSTRUCTION OF CLIMATE CHANGE INFORMATION CENTRE OFFICE
DEVELOPMENT IN SOKONI WARD - KILIFI MUNICIPALITY

ITEM	DESCRIPTION	AMOUNT
	<u>PROJECT MANAGERS EXPENSES</u>	
A.	Provide field allowance, mobile phone airtime, contract administration expenses and stationery worth Kenya Shillings Two Million Two Hundred Fifty Thousand (Kshs 2,250,000.00) only for the project management/implementation team for the duration of the contract period.	2,250,000.00
B.	Allow for Contractor's profit and overheads (.....%)	
	Carried to collection	

PROPOSED CONSTRUCTION OF CLIMATE CHANGE INFORMATION CENTRE OFFICE
DEVELOPMENT IN SOKONI WARD - KILIFI MUNICIPALITY

ITEM	DESCRIPTION	AMOUNT
A	<p><u>PARTICULARS OF INSERTIONS TO BE MADE IN APPENDIX TO CONTRACT AGREEMENT</u></p> <p>The following are the insertions to be made in the appendix to the Contract Agreement: -</p> <p>Period of Final Measurement 3 Months From Practical completion</p> <p>Defects Liability Period 6 Months from Practical completion</p> <p>Date for Possession To be agreed with the Project Manager</p> <p>Date for Completion ...54.. Weeks from date of Possession</p> <p>Liquidated and Ascertained At the rate of Kshs.. 30,000... per week or part thereof</p> <p>Prime cost sums for which The Contractor desires to tender</p> <p>Period of Interim Certificates Monthly</p> <p>Period of Honouring Certificates 30 days</p> <p>Percentage of Certified Value Retained 10%</p> <p>Limit of Retention Fund 10%</p>	
	Carried to collection	

PROPOSED CONSTRUCTION OF CLIMATE CHANGE INFORMATION CENTRE OFFICE
DEVELOPMENT IN SOKONI WARD - KILIFI MUNICIPALITY

ITEM	DESCRIPTION	AMOUNT
	<u>COLLECTION</u>	
	Brought forward from page PP/1	
	Brought forward from page PP/2	
	Brought forward from page PP/3	
	Brought forward from page PP/4	
	Brought forward from page PP/5	
	Brought forward from page PP/6	
	Brought forward from page PP/7	
	TOTAL FOR PARTICULAR PRELIMINARIES CARRIED TO GRAND SUMMARY	

GENERAL PRELIMINARIES

PROPOSED CONSTRUCTION OF CLIMATE CHANGE INFORMATION CENTRE OFFICE
DEVELOPMENT IN SOKONI WARD - KILIFI MUNICIPALITY

ITEM	DESCRIPTION	AMOUNT
	<u>GENERAL PRELIMINARIES</u>	
A.	<p>METHOD OF MEASUREMENT</p> <p>The Bills of Quantities have been prepared in accordance with the general Principles of the Standard Method of Measurement of Building Works for East Africa, Second Edition (Metric), published by the Architectural Association of Kenya, Chapter of Quantity Surveyors in June 2008.</p>	
B.	<p>PRICING ITEMS OF PRELIMINARIES AND PREAMBLES</p> <p>Prices will be inserted against items of Preliminaries in the Contractor's priced Bills of Quantities and Specification.</p> <p>The Contractor shall be deemed to have included in his prices or rates for the various items in the Bills of Quantities or Specification for all costs involved in complying with all the requirements for the proper execution of the whole of the works in the Contract.</p>	
C.	<p>ABBREVIATIONS</p> <p>Throughout these Bills, units of measurement and terms are abbreviated and shall be all the requirements for the proper execution of the whole of the works in the Contract.</p> <p>C.M. Shall mean cubic metre</p> <p>S.M. Shall mean square metre</p> <p>L.M. Shall mean linear metre</p> <p>MM Shall mean Millimetre</p> <p>Kg. Shall mean Kilogramme</p> <p>No. Shall mean Number</p> <p>Prs. Shall mean Pairs</p> <p>B.S. - Shall mean the British Standard Specification Published by the British Standards Institution, 2 Park Street, London W.I., England.</p> <p>Ditto - Shall mean the whole of the preceding description except as qualified in the description in which it occurs.</p> <p>m.s. Shall mean measured separately.</p> <p>a.b.d Shall mean as before described.</p>	
	Carried to collection	

PROPOSED CONSTRUCTION OF CLIMATE CHANGE INFORMATION CENTRE OFFICE
DEVELOPMENT IN SOKONI WARD - KILIFI MUNICIPALITY

ITEM	DESCRIPTION	AMOUNT
A.	<p>EXCEPTION TO THE STANDARD METHOD OF MEASUREMENT</p> <p>Attendance ; Clause B19(a) of the Standard Method of Measurement is deleted and the following clause is substituted:-</p> <p>Attendance on nominated Sub-Contractors shall be given as an item in each case shall be deemed to include: allowing use of standing scaffolding, mess rooms, sanitary accommodation and welfare facilities; provision of special scaffolding where necessary; providing space for office accommodation and for storage of plant and materials; providing light and water for their work; clearing away rubbish; unloading checking and hoisting: providing electric power and removing and replacing duct covers, pipe casings and the like necessary for the execution and testing of Sub- Contractors' work and being responsible for the accuracy of the same.</p> <p>Fix Only:-</p> <p>"Fix Only" shall mean take delivery at nearest railway station (Unless otherwise stated),pay all demurrage charges, load and transport to site where necessary, unload, store,unpack, assemble as necessary, distribute to position, hoist and fix only.</p>	
B.	<p>EMPLOYER</p> <p>The "Employer" is</p> <p>The term "Employer" and "Government" wherever used in the contract document shall be synonymous</p>	
C.	<p>PROJECT MANAGER</p> <p>The term "P.M." wherever used in these Bills of Quantities shall be deemed to imply the Project Manager as defined in Condition 1 of the Conditions of Contract or such person or persons as may be duly authorised to represent him on behalf of the Government.</p>	
D.	<p>ARCHITECT</p> <p>The term "Architect" shall be deemed to mean "The P.M." as defined above whose address unless otherwise notified is</p> <p>.....</p>	
E	<p>QUANTITY SURVEYOR</p> <p>The term "Quantity Surveyor" shall be deemed to mean "The P.M." as defined above whose address unless otherwise notified is</p> <p>.....</p>	
	Carried to collection	

PROPOSED CONSTRUCTION OF CLIMATE CHANGE INFORMATION CENTRE OFFICE
DEVELOPMENT IN SOKONI WARD - KILIFI MUNICIPALITY

ITEM	DESCRIPTION	AMOUNT
B	<p>ELECTRICAL ENGINEER</p> <p>The term "Electrical Engineer" shall be deemed to mean "The P.M." as defined above whose address unless otherwise notified is</p>	
C	<p>MECHANICAL ENGINEER</p> <p>The term "Mechanical Engineer" shall be deemed to mean "The P.M." as defined above whose address unless otherwise notified is</p>	
D	<p>STRUCTURAL ENGINEER</p> <p>The term "Structural Engineer" shall be deemed to mean "The P.M." as defined above whose address unless otherwise notified is</p>	
E	<p>FORM OF CONTRACT</p> <p>The Form of Contract shall be as stipulated in the Republic of Kenya's Standard Tender Document for Procurement of Building Works(2000 Edition) included herein</p> <p>The Conditions of Contract are also included herein</p> <p>Conditions of Contract</p> <p>These are numbered from 1 to 37 as set out in pages 18 to 38 of these tender documents.</p> <p>Particulars of insertions to be made in the Appendix to the Contract Agreement will be found in the Particular Preliminaries part of these Bills of Quantities</p>	
F	<p>BOND.</p> <p>The Contractor shall find and submit on the Form of Tender an approved bank who will be willing to be bound to the Government in an amount equal to five per cent (5) of the Contract amount for the due performances of the Contract up to the date of completion as certified by the PROJECT MANAGER and who will, when and if called upon, sign a Bond to that effect on the relevant standard form included herein. (without the addition of any limitations) on the same day as the Contract Agreement is signed, by the Government, the Contractor shall furnish within seven days another Surety to the approval of the Government.</p>	
	Carried to collection	

PROPOSED CONSTRUCTION OF CLIMATE CHANGE INFORMATION CENTRE OFFICE
DEVELOPMENT IN SOKONI WARD - KILIFI MUNICIPALITY

ITEM	DESCRIPTION	AMOUNT
A	<p>PLANT, TOOLS AND VEHICLES Allow for providing all scaffolding, plant, tools and vehicles required for the works except in so far as may be stated otherwise herein and except for such items specifically and only required for the use of nominated Sub-Contractors as described herein. No timber used for scaffolding, formwork or temporary works of any kind shall be used afterwards in the permanent work.</p>	
B	<p>TRANSPORT. Allow for transport of workmen, materials, etc., to and from the site at such hours and by such routes as may be permitted by the competent authorities.</p>	
C	<p>MATERIALS AND WORKMANSHIP. All materials and workmanship used in the execution of the work shall be of the best quality and description unless otherwise stated. The Contractor shall order all materials to be obtained from overseas immediately after the Contract is signed and shall also ensure they are onsite when required for use in the works. The Bills of Quantities shall not be used for the purpose of ordering materials.</p>	
D	<p>SIGN FOR MATERIALS SUPPLIED. The Contractor will be required to sign a receipt for all articles and materials supplied by the PROJECT MANAGER at the time of taking deliver thereof, as having received them in good order and condition, and will thereafter be responsible for any loss or damage and for replacements of any such loss or damage with articles and/or materials which will be supplied by the PROJECT MANAGER at the current market prices including Customs Duty and V.A.T., all at the Contractor's own cost and expense, to the satisfaction of the PROJECT MANAGER</p>	
E	<p>STORAGE OF MATERIALS The Contractor shall provide at his own risk and cost where directed on the site weather proof lock-up sheds and make good damaged or disturbed surfaces upon completion to the satisfaction of the PROJECT MANAGER Nominated Sub-Contractors are to be made liable for the cost of any storage accommodation provided especially for their use.</p>	
F	<p>SECURITY OF WORKS ETC. The Contractor shall be entirely responsible for the security of all the works stores, materials, plant, personnel, etc., both his own and sub-contractors' and must provide all necessary watching, lighting and other precautions as necessary to ensure security against theft, loss or damage and the protection of the public.</p>	
	Carried to collection	

PROPOSED CONSTRUCTION OF CLIMATE CHANGE INFORMATION CENTRE OFFICE
DEVELOPMENT IN SOKONI WARD - KILIFI MUNICIPALITY

ITEM	DESCRIPTION	AMOUNT
A	<p>SAMPLES</p> <p>The Contractor shall furnish at his own cost any samples of materials or workmanship including concrete test cubes required for the works that may be called for by the PROJECT MANAGER for his approval until such samples are approved by the PROJECT MANAGER and the PROJECT MANAGER, may reject any materials or workmanship not in his opinion to be up to approved samples. The PROJECT MANAGER shall arrange for the testing of such materials as he may at his discretion deem desirable, but the testing shall be made at the expense of the Contractor and not at the expense of the PROJECT MANAGER. The Contractor shall pay for the testing in accordance with the current scale of testing charges laid down by the Ministry of Roads, Housing and Public Works.</p> <p>The procedure for submitting samples of materials for testing and the method of marking for identification shall be as laid down by the PROJECT MANAGER The Contractor shall allow in his tender for such samples and tests except those in connection with nominated sub-contractors' work.</p>	
B	<p>GOVERNMENT ACTS REGARDING WORKPEOPLE ETC.</p> <p>Allow for complying with all Government Acts, Orders and Regulations in connection with the employment of Labour and other matters related to the execution of the works. In particular the Contractor's attention is drawn to the provisions of the Factory Act 1950 and his tender must include for all costs arising or resulting from compliance with any Act, Order or Regulation relating to Insurances, pensions and holidays for workpeople or so the safety, health and welfare of the workpeople.</p> <p>The Contractor must make himself fully acquainted with current Acts and Regulations, including Police Regulations regarding the movement, housing, security and control of labour, labour camps , passes for transport, etc. It is most important that the Contractor, before tendering, shall obtain from the relevant Authority the fullest information regarding all such regulations and/or restrictions which may affect the organisation of the works, supply and control of labour, etc., and allow accordingly in his tender. No claim in respect of want of knowledge in this connection will be entertained.</p>	
C	<p>PUBLIC AND PRIVATE ROADS.</p> <p>Maintain as required throughout the execution of the works and make good any damage to public or private roads arising from or consequent upon the execution of the works to the satisfaction of the local and other competent authority and the PROJECT MANAGER</p>	
D	<p>AREA TO BE OCCUPIED BY THE CONTRACTOR</p> <p>The area of the site which may be occupied by the Contractor for use of storage and for the purpose of erecting workshops, etc., shall be defined on site by the PROJECT MANAGER</p>	
	Carried to collection	

PROPOSED CONSTRUCTION OF CLIMATE CHANGE INFORMATION CENTRE OFFICE
DEVELOPMENT IN SOKONI WARD - KILIFI MUNICIPALITY

ITEM	DESCRIPTION	AMOUNT
A	<p>EXISTING PROPERTY. The Contractor shall take every precaution to avoid damage to all existing property including roads, cables, drains and other services and he will be held responsible for and shall make good all such damage arising from the execution of this contract at his own expense to the satisfaction of the PROJECT MANAGER</p>	
B	<p>VISIT SITE AND EXAMINE DRAWINGS. The Contractor is recommended to examine the drawings and visit the site the location of which is described in the Particular Preliminaries hereof. He shall be deemed to have acquainted himself therewith as to its nature, position, means of access or any other matter which, may affect his tender. No claim arising from his failure to comply with this recommendation will be considered.</p>	
C	<p>ACCESS TO SITE AND TEMPORARY ROADS. Means of access to the Site shall be agreed with the PROJECT MANAGER prior to commencement of the work and Contractor must allow for building any necessary temporary access roads for the transport of the materials, plant and workmen as may be required for the complete execution of the works including the provision of temporary culverts, crossings, bridges, or any other means of gaining access to the Site. Upon completion of the works, the Contractor shall remove such temporary access roads; temporary culverts, bridges, etc., and make good and reinstate all works and surfaces disturbed to the satisfaction of the PROJECT MANAGER.</p>	
D	<p>OFFICE ETC. FOR THE PROJECT MANAGER The Contractor shall provide, erect and maintain where directed on site and afterwards dismantle the site office of the standard type, complete with furniture. He shall also provide a strong metal trunk complete with strong hasp and staple fastening and two keys. He shall provide, erect and maintain a lock-up type water or bucket closet for the sole use of the PROJECT MANAGER including making temporary connections to the drain where applicable to the satisfaction of Government and Medical Officer of Health and shall provide services of cleaner and pay all conservancy charges and keep both office and closet in a clean and sanitary condition from commencement to the completion of the works and dismantle and make good disturbed surfaces. The office and closet shall be completed before the Contractor is permitted to commence the works. The Contractor shall make available on the Site as and when required by the "PROJECT MANAGER" a modern and accurate level together with levelling staff, ranging rods and 50 metre metallic or linen tape.</p>	
E	<p>SANITATION OF THE WORKS The Sanitation of the works shall be arranged and maintained by the Contractor to the satisfaction of the Government and/or Local Authorities, Labour Department and the PROJECT MANAGER</p>	
	Carried to collection	

PROPOSED CONSTRUCTION OF CLIMATE CHANGE INFORMATION CENTRE OFFICE
DEVELOPMENT IN SOKONI WARD - KILIFI MUNICIPALITY

ITEM	DESCRIPTION	AMOUNT
A	<p>WATER AND ELECTRICITY SUPPLY FOR THE WORKS The Contractor shall provide at his own risk and cost all necessary water, electric light and power required for use in the works. The Contractor must make his own arrangements for connection to the nearest suitable water main and for metering the water used. He must also provide temporary tanks and meters as required at his own cost and clear away when no longer required and make good on completion to the entire satisfaction of the PROJECT MANAGER . The Contractor shall pay all charges in connection herewith. No guarantee is given or implied that sufficient water will be available from mains and the Contractor must make his own arrangements for augmenting this supply at his own cost. Nominated Sub--contractors are to be made liable for the cost of any water or electric current used and for any installation provided especially for their own use.</p>	
B	<p>SUPERVISION AND WORKING HOURS The works shall be executed under the direction and to the entire satisfaction in all respects of the PROJECT MANAGER who shall at all times during normal working hours have access to the works and to the yards and workshops of the Contractor and sub-Contractors or other places where work is being prepared for the contract.</p>	
C	<p>PROVISIONAL SUMS. The term "Provisional Sum" wherever used in these Bills of Quantities shall have the meaning stated in Section A item A7(i) of the Standard Method of Measurement. Such sums are net and no addition shall be made to them for profit.</p>	
D	<p>PRIME COST (OR P.C.) SUMS. The term "Prime Cost Sum" or "P.C. Sum" wherever used in these Bills of Quantities shall have the meaning stated in Section A item A7 (ii) of the Standard Method of Measurement. Persons or firms nominated by the PROJECT MANAGER to execute work or to provide and fix materials or goods are described herein as Nominated Sub-Contractors. Persons or firms so nominated to supply goods or materials are described herein as Nominated Suppliers.</p>	
E	<p>PROGRESS CHART. The Contractor shall provide within two weeks of Possession of Site and in agreement with the PROJECT MANAGER a Progress Chart for the whole of the works including the works of Nominated Sub-Contractors ; one copy to be handed to the PROJECT MANAGER and a further copy to be retained on Site. Progress to be recorded and chart to be amended as necessary as the work proceeds.</p>	
	Carried to collection	

PROPOSED CONSTRUCTION OF CLIMATE CHANGE INFORMATION CENTRE OFFICE
DEVELOPMENT IN SOKONI WARD - KILIFI MUNICIPALITY

ITEM	DESCRIPTION	AMOUNT
A	<p>ADJUSTMENT OF P.C. SUMS. In the final account all P.C. Sums shall be deducted and the amount properly expended upon the PROJECT MANAGER'S order in respect of each of them added to the Contract sum. The Contractor shall produce to the PROJECT MANAGER such quotations, invoices or bills, properly received, as may be necessary to show the actual details of the sums paid by the Contractor. Items of profit upon P.C. Sums shall be adjusted in the final account pro-rata to the amount paid. Items of "attendance"</p> <p>Should the Contractor be permitted to tender and his tender be accepted of any work for which a P.C. Sum is included in these Bill of Quantities profit and attendance will be allowed at the same rate as it would be if the work were executed by a Nominated Sub-Contractor.</p>	
B	<p>ADJUSTMENT OF PROVISIONAL SUMS. In the final account all Provisional Sums shall be deducted and the value of the work properly executed in respect of them upon the PROJECT MANAGER's order added to the Contract Sum. Such work shall be valued as described for Variations, but should any part of the work be executed by a Nominated Sub-Contractor, the value of such work or articles for the work to be supplied by a Nominated Supplier, the value of such work or articles shall be treated as a P.C. Sum and profit and attendance comparable to that contained in the priced Bills of Quantities for similar items added.</p>	
C	<p>NOMINATED SUB-CONTRACTORS When any work is ordered by the PROJECT MANAGER to be executed by nominated sub-contractors, the Contractor shall enter into sub-contracts and shall thereafter be responsible for such sub-contractors in every respect. Unless otherwise described the Contractor is to provide for such Sub-Contractors any or all of the facilities described in these Preliminaries. The Contractor should price for these with the nominated Sub-contract Contractor's work concerned in the P.C. Sums under the description "add for Attendance".</p>	
D	<p>DIRECT CONTRACTS Notwithstanding the foregoing conditions, the Government reserves the right to place a "Direct Contract" for any goods or services required in the works which are covered by a P.C. Sum in the Bills of Quantities and to pay for the same direct. In any such instances, profit relative to the P.C. Sum the priced Bills of Quantities will be adjusted as described for P.C. Sums and allowed.</p>	
	Carried to collection	

PROPOSED CONSTRUCTION OF CLIMATE CHANGE INFORMATION CENTRE OFFICE
DEVELOPMENT IN SOKONI WARD - KILIFI MUNICIPALITY

ITEM	DESCRIPTION	AMOUNT
A	<p>ATTENDANCE UPON OTHER TRADESMEN, ETC. The Contractor shall allow for the attendance of trade upon trade and shall afford any tradesmen or other persons employed for the execution of any work not included in this Contract every facility for carrying out their work and also for use of his ordinary scaffolding. The Contractor, however, shall not be required to erect any special scaffolding for them. The Contractor shall perform such cutting away for and making good after the work of such tradesmen or persons as may be ordered by the PROJECT MANAGER and the work will be measured and paid for to the extent executed at rates provided in these Bills.</p>	
B	<p>INSURANCE The Contractor shall insure as required in Clause 30 of the Conditions of Contract. No payment on account of the work executed will be made to the Contractor until he has satisfied the PROJECT MANAGER either by production of an Insurance Policy or and Insurance Certificate that the provision of the foregoing Insurance Clauses have been complied with in all respects. Thereafter the PROJECT MANAGER shall from time to time ascertain that premiums are duly paid up by the Contractor who shall if called upon to do so, produce the receipted premium renewals for the PROJECT MANAGER's inspection.</p>	
C	<p>PROVISIONAL WORK All work described as "Provisional" in these Bills of Quantities is subject to remeasurement in order to ascertain the actual quantity executed for which payment will be made. All "Provisional" and other work liable to adjustment under this Contract shall left uncovered for a reasonable time to allow all measurements needed for such adjustment to be taken by the PROJECT MANAGER Immediately the work is ready for measuring, the Contractor shall give notice to the PROJECT MANAGER. If the Contractor makes default in these respects he shall if the PROJECT MANAGER so directs uncover the work to enable all measurements to be taken and afterwards reinstate at his own expense.</p>	
D	<p>ALTERATIONS TO BILLS, PRICING, ETC. Any unauthorised alteration or qualification made to the text of the Bills of Quantities may cause the Tender to be disqualified and will in any case be ignored. The Contractor shall be deemed to have made allowance in his prices generally to cover any items against which no price has been inserted in the priced Bills of Quantities. All items of measured work shall be priced in detail and the Tenders containing Lump Sums to cover trades or groups of work must be broken down to show the price of each item before they will be accepted.</p>	
	Carried to collection	

PROPOSED CONSTRUCTION OF CLIMATE CHANGE INFORMATION CENTRE OFFICE
DEVELOPMENT IN SOKONI WARD - KILIFI MUNICIPALITY

ITEM	DESCRIPTION	AMOUNT
A	<p>BLASTING OPERATIONS Blasting will only be allowed with the express permission of the PROJECT MANAGER in writing. All blasting operations shall be carried out at the Contractor's sole risk and cost in accordance with any Government regulations in force for the time being, and any special regulations laid down by the PROJECT MANAGER governing the use and storage of explosives.</p>	
B	<p>MATERIALS ARISING FROM EXCAVATIONS Materials of any kind obtained from the excavations shall be the property of the Government. Unless the PROJECT MANAGER directs otherwise such materials shall be dealt with as provided in the Contract. Such materials shall only be used in the works, in substitution of materials which the Contractor would otherwise have had to supply with the written permission of the PROJECT MANAGER. Should such permission be given, the Contractor shall make due allowance for the value of the materials so used at a price to be agreed.</p>	
C	<p>PROTECTION OF THE WORKS. Provide protection of the whole of the works contained in the Bills of Quantities, including casing , casing up, covering or such other means as may be necessary to avoid damage to the satisfaction of the PROJECT MANAGER and remove such protection when no longer required and make good any damage which may nevertheless have been done at completion free of cost to the Government.</p>	
D	<p>REMOVAL OF RUBBISH ETC. Removal of rubbish and debris from the Buildings and site as it accumulates and at the completion of the works and remove all plant, scaffolding and unused materials at completion.</p>	
E	<p>WORKS TO BE DELIVERED UP CLEAN Clean and flush all gutters, rainwater and waste pipes, manholes and drains, wash (except where such treatment might cause damage) and clean all floors, sanitary fittings, glass inside and outside and any other parts of the works and remove all marks, blemishes, stains and defects from joinery, fittings and decorated surfaces generally, polish door furniture and bright parts of metalwork and leave the whole of the buildings watertight, clean, perfect and fit for occupation to the approval of the PROJECT MANAGER</p>	
	Carried to collection	

PROPOSED CONSTRUCTION OF CLIMATE CHANGE INFORMATION CENTRE OFFICE
DEVELOPMENT IN SOKONI WARD - KILIFI MUNICIPALITY

ITEM	DESCRIPTION	AMOUNT
A.	<p>GENERAL SPECIFICATION. For the full description of materials and workmanship, method of execution of the work and notes for pricing, the Contractor is referred to the Ministry of Roads, Public Works and Housing General Specification dated 1976 or any subsequent revision thereof which is issued as a separate document, and which shall be allowed in all respects unless it conflicts with the General Preliminaries, Trade Preambles or other items in these Bills of Quantities.</p>	
B.	<p>TRAINING LEVY The Contractor's attention is drawn to legal notice No. 237 of October, 1971, which requires payment by the Contractor of a Training Levy at the rate of 1/4 % of the Contract sum on all contracts of more than Kshs. 50,000.00 in value.</p>	
C.	<p>MATERIALS ON SITE All materials for incorporation in the works must be stored on or adjacent to the site before payment is effected unless specifically exempted by the PROJECT MANAGER. This includes the materials of the Main Contractor, Nominated Sub-Contractors and Nominated Suppliers.</p>	
D.	<p>HOARDING The Contractor shall enclose all the site under construction with a hoarding 2400 mm high consisting of iron sheets gauge 30 on 100 x 50 mm 2nd grade treated sawn cypress timber posts firmly secured at 1800 mm centres with two 75 x 50 mm 2nd grade treated sawn cypress timber rails (Approximately 300 linear metres). The Contractor is in addition required to take all precautions necessary for the safe custody of the works, materials, plant, public and Employer's property on the site.</p>	
E.	<p>CONTRACTOR'S SUPERINTENDENCE/SITE AGENT The Contractor shall constantly keep on the works a literate English speaking Agent or Representative, competent and experienced in the kind of work involved who shall give his whole experience in the kind of work involved and shall give his whole time to the superintendence of the works. Such Agent or Representative shall receive on behalf of the Contractor all directions and instructions from the Project Manager and such directions shall be deemed to have been given to the Contractor in accordance with the Conditions of Contract.</p>	
	Carried to collection	

PROPOSED CONSTRUCTION OF CLIMATE CHANGE INFORMATION CENTRE OFFICE
DEVELOPMENT IN SOKONI WARD - KILIFI MUNICIPALITY

ITEM	DESCRIPTION	AMOUNT
	<u>COLLECTION</u>	
	Brought Forward From Page GP/ 1	
	Brought Forward From Page GP/ 2	
	Brought Forward From Page GP/ 3	
	Brought Forward From Page GP/ 4	
	Brought Forward From Page GP/ 5	
	Brought Forward From Page GP/ 6	
	Brought Forward From Page GP/ 7	
	Brought Forward From Page GP/ 8	
	Brought Forward From Page GP/ 9	
	Brought Forward From Page GP/ 10	
	Brought Forward From Page GP/ 11	
	TOTAL FOR GENERAL PRELIMINARIES CARRIED TO GRAND SUMMARY	

BUILDERS WORKS

PROPOSED CONSTRUCTION OF CLIMATE CHANGE INFORMATION CENTRE OFFICE
DEVELOPMENT IN SOKONI WARD - KILIFI MUNICIPALITY

ITEM	DESCRIPTION	QTY	UNIT	RATE	AMOUNT
	<p><u>ELEMENT NO. 1</u></p> <p><u>Please note that ALL substructure works are Measured Provisionally. The contractor must ensure that the actual measurements are taken by the Project Manager before any works are covered. Failure to do so will necessitate works to be open up for verification at your (contractor's) cost.</u></p> <p><u>NOTE: Classes of Rock</u></p> <p><u>(1) Class 1 :</u> Soft rock of the type known locally as "CORAL" which in the opinion of the Engineer cannot be considered as hard rock shall be known as Class 1 rock. Soft Rock shall be rock with compressive strength not exceeding 15N/mm². Murram and Kunker is specifically excluded and will be reckoned as normal/common excavation. Extremely weathered and weak Tuff shall also be considered as normal excavation.</p> <p><u>(2) Class 2 :</u> Class 2 Rock shall be with compressive strength exceeding 15N/mm². This type of rock contains stones and boulders of unweathered or incompletely weathered Tuff, trachyte, black trap or lava with compressive strength exceeding 15N/mm² in a formation which is massive and geologically homogeneous. A boulder or outcrop with such compressive strength will be deemed to be Class 2 rock or Hard Rock</p> <p>The opinion of the Engineer in classifying rock shall be final and binding.</p> <p>Explosives must not be used without the prior approval of the Engineer. Blasting operations are carried out at the Contractor's sole risk, and all blasting must be carried out in accordance with government regulations and approval</p>				
	Carried to collection				

PROPOSED CONSTRUCTION OF CLIMATE CHANGE INFORMATION CENTRE OFFICE
DEVELOPMENT IN SOKONI WARD - KILIFI MUNICIPALITY

ITEM	DESCRIPTION	QTY	UNIT	RATE	AMOUNT
	<u>SUBSTRUCTURES (All provisional)</u>				
	Site Preparation				
A	Clear site to remove all top soil, vegetation, shrubs, undergrowth, small trees and grub up roots and burn all the arising	851	SM		
	Trees				
B	Cut trees, grub up roots and cart away as directed by the Project Manager. Girth 1200 -1500 mm girth	2	NO		
C	Cut trees, grub up roots and cart away as directed by the Project Manager. Girth 1500 -1800 mm girth	2	NO		
	Excavation (Note that all excavations are measured nett and no allowance for working space provided)				
D	Mass excavation to reduce levels not exceeding 1500 mm deep, average 300 mm deep	340	CM		
E	Excavate for foundation trenches from reduced level not exceeding 1.50 metres deep	263	CM		
F	Excavate for column bases from reduced level not exceeding 1.50 metres deep	212	CM		
G	Extra over all descriptions of excavations and removal from site for breaking up rocks: irrespective of class	190	CM		
	Disposal of excavated material				
H	Fillings around sub- walls: backfill and compact in 150 mm layers: selected excavated materials	240	CM		
I	Remove surplus spoil from site and deposit in spoil heaps and later spread on site as directed	575	CM		
	Carried to collection				

PROPOSED CONSTRUCTION OF CLIMATE CHANGE INFORMATION CENTRE OFFICE
DEVELOPMENT IN SOKONI WARD - KILIFI MUNICIPALITY

ITEM	DESCRIPTION	QTY	UNIT	RATE	AMOUNT
	Planking and strutting				
A	Planking and strutting to sides of all excavations: keep excavations free from all fallen materials		ITEM		
	Disposal of Water				
B	Keep excavations free from all water including spring or running water.		ITEM		
	Hardcore Filling				
C	300mm Thick layer of imported hardcore filling including levelling and consolidating in 150mm layers	591	SM		
	Imported Filling				
D	Imported filling in selected and approved murrum including levelling and consolidating in 150mm layers including watering	340	CM		
	Murrum				
E	50mm Thick Quarry dust blinding to the surface of hardcore rolled smooth to receive polythene sheeting	591	SM		
	Insecticide treatment Premise SC or other equal and approved termiticide 0.5% solution to be applied at the rate of 4 litres per square metre on top of hardcore filling over foundation walls				
F	To Quarry dust surface	650	SM		
	<u>CONCRETE WORK</u>				
	Insitu concrete mix (1:4:8) in;				
G	50 mm Blinding to strips	176	SM		
H	50 mm Blinding to column bases	141	SM		
	Carried to collection				

PROPOSED CONSTRUCTION OF CLIMATE CHANGE INFORMATION CENTRE OFFICE
DEVELOPMENT IN SOKONI WARD - KILIFI MUNICIPALITY

ITEM	DESCRIPTION	QTY	UNIT	RATE	AMOUNT
	Insitu reinforced concrete: (mix 1:1¹/₂:3) grade 25 (20 mm aggregate): vibrated in:-				
A	Strip foundation	35	CM		
B	Column bases	42	CM		
C	Columns	4	CM		
D	Ground beam	9	CM		
E	Ramp	1	CM		
F	150mm Thick ground floor slab	650	SM		
	Steel reinforcement as described including cutting to length, bending, hoisting and fixing including all necessary tying wires and spacing blocks.				
	Ribbed bars to KS ISO 6935-2:2007				
G	8mm diameter	1,585	KG		
H	10mm diameter	1,034	KG		
I	12mm diameter	161	KG		
J	16mm diameter	6,677	KG		
	Fabric Mesh Reinforcement				
K	BRC Fabric mesh reinforcement Ref. A142; weighing 2.22kg per square metre(measured net no allowances made for laps) including bends tying wire and spacer blocks.	650	SM		
	Carried to collection				

PROPOSED CONSTRUCTION OF CLIMATE CHANGE INFORMATION CENTRE OFFICE
DEVELOPMENT IN SOKONI WARD - KILIFI MUNICIPALITY

ITEM	DESCRIPTION	QTY	UNIT	RATE	AMOUNT
	Sawn formwork: to				
A	Vertical: sides of foundations in trenches	117	SM		
B	Vertical: sides of column bases	86	SM		
C	Vertical: sides of columns	53	SM		
D	Vertical sides of ground beam	88	SM		
E	Edges: slab over 75 but not exceeding 150 mm wide	117	LM		
F	Edges: ramp over 75 but not exceeding 150 mm wide	12	LM		
	Walling				
	Approved local stone; roughly squared; bedded and jointed in cement sand mortar (1:3)				
G	200 mm thick walls reinforced with hoop iron at every alternate course	527	SM		
	DAMP PROOFING				
	1000 Gauge polythene; 150mm laps; no allowances made for laps				
H	Horizontal; over 300mm wide	650	SM		
	Plinth Finishes				
I	15mm Thick cement sand (1:3) rendering to plinth; wood float finish	53	SM		
J	Prepare and apply three coats of premium quality bituminous paint to rendered walls; externally	53	SM		
	Carried to collection				

PROPOSED CONSTRUCTION OF CLIMATE CHANGE INFORMATION CENTRE OFFICE
DEVELOPMENT IN SOKONI WARD - KILIFI MUNICIPALITY

ITEM	DESCRIPTION	QTY	UNIT	RATE	AMOUNT
	Paving slabs				
A	Excavate trench for edge wall foundation average 600mm deep, part return fill and ram remainder cart away	43	CM		
B	Plain concrete (1:3:6) in strip foundation	11	CM		
C	200mm thick coral block edge walling in cement sand (1:3) mortar	72	SM		
D	300mm thick approved hardcore handpacked and compacted as before described	144	SM		
E	Treat hardcore surface and tops of walls with approved insecticide	144	SM		
F	600x600x50mm pre-cast concrete (1:2:4) paving slabs pointed in cement sand (1:3) mortar and laid on 50mm approved bed of sand	144	SM		
	Carried to collection				
	<u>COLLECTION</u>				
	<u>SUBSTRUCTURE WORK</u>				
	Brought forward from page BL/2				
	Brought forward from page BL/3				
	Brought forward from page BL/4				
	Brought forward from page BL/5				
	Brought down from page BL/6 above				
	TOTAL FOR SUBSTRUCTURE CARRIED TO SUMMARY				

PROPOSED CONSTRUCTION OF CLIMATE CHANGE INFORMATION CENTRE OFFICE
DEVELOPMENT IN SOKONI WARD - KILIFI MUNICIPALITY

ITEM	DESCRIPTION	QTY	UNIT	RATE	AMOUNT
	<u>ELEMENT NO. 2</u>				
	<u>RC SUPERSTRUCTURE</u>				
	In situ reinforced concrete: (mix 1:1¹/₂:3) grade 25 (20 mm aggregate): vibrated in:-				
A	Beams	53	CM		
B	Columns	19	CM		
C	Staircase	5	CM		
D	150mm thick suspended floor slab	613	SM		
E	150mm thick suspended roof slab	650	SM		
F	150mm thick suspended landings	9	SM		
G	150mm thick suspended slab above staircase	23	SM		
	Sawn formwork: to				
H	Sides of Columns	281	SM		
I	Sides and soffits of beams	527	SM		
J	Soffites of suspended floor slab	613	SM		
K	Soffites of suspended roof slab	650	SM		
L	Soffites of landings	9	SM		
M	Soffites of suspended slab above staircase	23	SM		
N	Sloping soffites of staircase	22	SM		
O	Extreme edges of staircase average 300mm wide with profile to treads and risers	15	LM		
P	Edges of suspended slabs 75-150mm	238	LM		
Q	Risers 150mm high	66	LM		
	Carried to collection				

PROPOSED CONSTRUCTION OF CLIMATE CHANGE INFORMATION CENTRE OFFICE
DEVELOPMENT IN SOKONI WARD - KILIFI MUNICIPALITY

ITEM	DESCRIPTION	QTY	UNIT	RATE	AMOUNT
	<p>Steel reinforcement as described including cutting to length, bending, hoisting and fixing including all necessary tying wires and spacing blocks.</p> <p>Ribbed bars to KS ISO 6935-2:2007</p>				
A	16mm Diameter bars	10,957	KG		
B	12mm Diameter bars	112	KG		
C	10mm Diameter bars	16,599	KG		
D	8mm Diameter bars	3,169	KG		
	Carried to collection				
	<p><u>COLLECTION</u></p> <p><u>RC SUPERSTRUCTURE</u></p> <p>Brought forward from page BL/7</p> <p>Brought down from page BL/8 above</p>				
	TOTAL FOR RC SUPERSTRUCTURE CARRIED TO SUMMARY				

PROPOSED CONSTRUCTION OF CLIMATE CHANGE INFORMATION CENTRE OFFICE
DEVELOPMENT IN SOKONI WARD - KILIFI MUNICIPALITY

ITEM	DESCRIPTION	QTY	UNIT	RATE	AMOUNT
	<u>ELEMENT NO. 3</u>				
	<u>WALLING</u>				
	Approved natural stone; fine squared chisel dressed one side; bedded and jointed in cement mortar (1:3)				
A	Walls 200 mm thick reinforced with and including 20swqx25mm wide hoop iron in every alternate course externally	526	SM		
B	Ditto but parapet walling	131	SM		
	Approved natural stone; fine squared chisel dressed one side; bedded and jointed in cement mortar (1:3)				
	Walls 200 mm thick reinforced with and including 20swqx25mm wide hoop iron in every alternate course internally	534	SM		
C	Ditto walls 150 mm thick internally	92	SM		
	Bituminous or other equal approved damp-proof course; 3 ply membrane bedded and jointed in cement sand (1:3) mortar including 150mm end taps				
D	Horizontal; 200mm wide under walls	123	LM		
	TOTAL FOR WALLING CARRIED TO SUMMARY				

PROPOSED CONSTRUCTION OF CLIMATE CHANGE INFORMATION CENTRE OFFICE
DEVELOPMENT IN SOKONI WARD - KILIFI MUNICIPALITY

ITEM	DESCRIPTION	QTY	UNIT	RATE	AMOUNT
	<u>ELEMENT NO. 5</u>				
	<u>FLAT ROOF FINISHES AND RAINWATER DISPOSAL</u>				
	Flat Roof Finishes				
A	75mm thick (average) light weight roof screed consisting of cement, sand and pumice or vermiculite (1:3:7) finished with 12mm thick cement sand (1:4) topping complete with burnt clay tiles laid to falls to flat roof, all to project manager's approval	650	SM		
B	300 x 50 mm high precast concrete coping weathered and throated on both sides and jointed to wall in cement sand mortar 1:3 all to approval	109	LM		
C	Ditto but 500 x 500 mm pier coping	23	NO		
	Rainwater Goods				
	The following in 26 Gauge Galvanised mild steel sheeting				
D	Extra over for forming 160mm diameter hole for down pipe	8	NO		
E	160mm downpipes in concrete columns/ walling to approval	64	LM		
F	Extra over downpipe for 160mm diameter anti splash shoe	8	NO		
G	Extra, 150mm flubora outlets including galvanised expanded metal mesh	8	NO		
H	450 mm girth flashing one end built in mortar in groove in wall, other dressed over roof covering	70	LM		
	TOTAL FOR FLAT ROOF FINISHES AND RAINWATER DISPOSAL CARRIED TO SUMMARY				

PROPOSED CONSTRUCTION OF CLIMATE CHANGE INFORMATION CENTRE OFFICE
DEVELOPMENT IN SOKONI WARD - KILIFI MUNICIPALITY

ITEM	DESCRIPTION	QTY	UNIT	RATE	AMOUNT
	<u>ELEMENT NO. 2</u>				
	<u>DOORS</u>				
	Wrot mahogany/ mvule or equal and approved hardwood				
A	45mm thick (finished) framed panelled Double Leaf fanlight door overall size 1500x2700mm high; comprising 2 No. equal openable leafs each size 750x2400mm high, 300mm high fanlight. comprising 150x45mm rebated top rail, twice rebated middle rail, 200x45mm rebated bottom rail, panel filled with and including 25mm thick hardwood panels including 40x20mm moulded beading all finished for painting (m/s), all to detail and approval	4	No.		
	Solid core flush doors; finished with scratch proof mahogany laminate; hardwood lipped on all edges and to look like framed door; Complete with solid blocking for pressed ironmongery:				
B	Single leaf door, 45mm thick; overall size 900x2400mm high, 300mm high fanlight	27	No.		
C	Single leaf door, 45mm thick; overall size 800x2400mm high, 300mm high fanlight	16	No.		
	The following in wrot Mvule/Mahogany or any equal and approved hardwood				
D	150 x 50mm frame with two labours	28	LM		
E	150 x 50 mm transome	6	LM		
F	100 x 50mm frame with two labours	244	LM		
G	100 x 50 mm transome	37	LM		
H	25 x 12m Quadrant	272	LM		
I	50 x 25mm. Splayed architrave.	272	LM		
J	25 x 12m glazing bead	117	LM		
	Carried to collection				

PROPOSED CONSTRUCTION OF CLIMATE CHANGE INFORMATION CENTRE OFFICE
DEVELOPMENT IN SOKONI WARD - KILIFI MUNICIPALITY

ITEM	DESCRIPTION	QTY	UNIT	RATE	AMOUNT
	Glazing				
A	5mm clear glass pane fixed with glazing bead (measured separately)	15	SM		
	Metal fixing cramps				
B	30 x 3mm. Approved door cramps 250mm. Long once bent one end drilled and screwed to wood	282	NO		
	Ironmongery				
	<u>Supply and fix the following ironmongery from 'UNION' or other equal & approved manufacturer including all necessary matching screws.</u>				
C	3 - Lever mortice lock with aluminium furniture	4	NO		
D	2 - Lever mortice lock with aluminium furniture	28	NO		
E	2 - Lever bathroom mortice lock with aluminium furniture	15	NO		
F	Heavy duty double action hinges to approved sample (1.5 pairs on each leaf)	3	PRS		
G	100mm. Pressed aluminium butt hinges; 24 No.102 (1.5 pairs on each leaf)	66	PRS		
H	38mm. Diameter door stop No.8400	47	NO		
I	150 x 150mm Brass gender/ disabled indicator plate	4	NO		
	<u>Painting and Decoration</u>				
	Prepare and apply one coat aluminium primer before fixing: to backing of wood				
J	Surfaces over 200 but not exceeding 300mm	315	LM		
K	Surfaces not exceeding 100mm	661	LM		
	Carried to collection				

PROPOSED CONSTRUCTION OF CLIMATE CHANGE INFORMATION CENTRE OFFICE
DEVELOPMENT IN SOKONI WARD - KILIFI MUNICIPALITY

ITEM	DESCRIPTION	QTY	UNIT	RATE	AMOUNT
	Prepare and apply three coats of premium quality clear varnish; Matt quality to:-				
A	General surfaces of wood exceeding 200mm but not exceeding 300mm girth	315	LM		
B	Surfaces not exceeding 100mm	661	LM		
C	Doors both internally and externally	191	SM		
	Carried to collection				
	<p><u>COLLECTION</u></p> <p><u>DOORS</u></p> <p>Brought forward from page BL/11</p> <p>Brought forward from page BL/12</p> <p>Brought down from page BL/13 above</p>				
	TOTAL FOR DOORS CARRIED TO SUMMARY				

PROPOSED CONSTRUCTION OF CLIMATE CHANGE INFORMATION CENTRE OFFICE
DEVELOPMENT IN SOKONI WARD - KILIFI MUNICIPALITY

ITEM	DESCRIPTION	QTY	UNIT	RATE	AMOUNT
	<u>ELEMENT NO. 3</u>				
	<u>WINDOWS</u>				
	Heavy Duty Natural Anodised Aluminium windows to B.S. 4813 to be executed by an approved sub contractor				
	The following in Heavy Duty Natural Anodised Aluminium windows from approved manufacturer(s) complete with 80x55x3 mm frames mullions trasomes railing and necessary intermidiate reinforcement elements including all weather strips, rubber glazing strips, couplings, ironmongery icluding hinges, fasteners and stays, sliding rails (where necessary) bars; panes left open for glazing to Architects detail				
A	Window WD-001 Size 1800x1700mm high	35	NO		
B	Window WD-002 Size 800x2700mm high	6	NO		
C	Window WD-002 Size 800x1000mm high	17	NO		
	Window Sills				
D	200x50mm pre-cast concrete window sill bedded and pointed in cement sand(1:3) mortar, weathred and throated all to Architects detail and approval	99	LM		
	<u>Glazing</u>				
	Blue stopsol sheet glass and glazing with aluminium beadings				
E	6mm thick glass in panes (0.50-1.00m ²)	120	SM		
F	Ditto but sunblasted obscure glass panes	14	SM		
	Carried to collection				

PROPOSED CONSTRUCTION OF CLIMATE CHANGE INFORMATION CENTRE OFFICE
DEVELOPMENT IN SOKONI WARD - KILIFI MUNICIPALITY

ITEM	DESCRIPTION	QTY	UNIT	RATE	AMOUNT
	Burglar proofing grilles				
A	Mild steel grille framed with 40 x 40 x 3mm thick RHS sections and 16mm diameter bars welded together at 200 mm centres bothways; including assembly and fixing to opening cutting and pinning lugs to concrete and bedding frame in cement sand mortar (1:4); all to design and pattern as directed.	134	SM		
	Window blinds				
	Supply and fix venetian blinds complete with tracks to the project manager's approval and as described				
B	Overall size 2100x2000mm high	35	No		
	<u>Painting and decorating:</u>				
	Prepare and apply three coats high quality gloss paint to:				
C	Surfaces of window cill 200mm but not exceeding 300mm girth	99	LM		
D	To burglar-proofing grilles; internally/externally	268	SM		
	Carried to collection				
	<u>COLLECTION</u>				
	<u>WINDOWS</u>				
	Brought forward from page BL/14				
	Brought down from page BL/15 above				
	TOTAL FOR WINDOWS CARRIED TO SUMMARY				

PROPOSED CONSTRUCTION OF CLIMATE CHANGE INFORMATION CENTRE OFFICE
DEVELOPMENT IN SOKONI WARD - KILIFI MUNICIPALITY

ITEM	DESCRIPTION	QTY	UNIT	RATE	AMOUNT
	<u>ELEMENT NO. 8</u>				
	<u>BALUSTRADES AND RAILINGS</u>				
	"All Provisional"				
	Handrail - Stainless Steel				
A	50x1.5mm diameter CHS stainless steel butt fixed to 38x1.5mm diameter stainless steel balusters (m.s) complete with and including all necessary accessories	30	LM		
C	Extra over ditto for rounded edges	8	NO		
D	Extra over ditto for mitred angles	8	NO		
	Metal Work				
E	38x1.5mm diameter stainless steel balusters grouted to walling or concrete work complete with and including all necessary accessories	151	LM		
F	19mm x1.5mm thick stainless steel rails fixed to balusters complete with and including all necessary accessories	90	LM		
	TOTAL FOR BALUSTRADES AND RAILINGS CARRIED TO SUMMARY				

PROPOSED CONSTRUCTION OF CLIMATE CHANGE INFORMATION CENTRE OFFICE
DEVELOPMENT IN SOKONI WARD - KILIFI MUNICIPALITY

ITEM	DESCRIPTION	QTY	UNIT	RATE	AMOUNT
	<u>ELEMENT NO. 9</u>				
	<u>FIXTURES AND FITTINGS:</u> "All Provisional"				
	<u>Worktop</u>				
	Concrete Works				
A	Plain concrete (1:3:6) in plinth	11	SM		
B	Reinforced concrete (1:2:4) in 100mm worktops	11	SM		
	Formwork				
C	Sawn softwood formwork to soffites of worktops	11	SM		
D	Edges of worktops 75-150mm high	29	LM		
E	10mm diameter ribbed reinforcement bars	93	KG		
F	200 mm thick coral block walling reinforced with and including 20swqx25mm wide hoop iron in every alternate course	17	SM		
G	15mm thick cement sand (1:3) plaster of worktop	11	SM		
H	Ditto walls	56	SM		
I	20mm thick polished Granite on surfaces of worktop	11	SM		
J	Ditto but to 100 mm wide edges	29	LM		
	<u>Shelving</u>				
K	75x50 mm thick Mahogany members	24	LM		
L	Ditto plugged to walls	18	LM		
M	25mm meru oak veneered both sides block board shelves	36	SM		
	Carried to collection				

PROPOSED CONSTRUCTION OF CLIMATE CHANGE INFORMATION CENTRE OFFICE
DEVELOPMENT IN SOKONI WARD - KILIFI MUNICIPALITY

ITEM	DESCRIPTION	QTY	UNIT	RATE	AMOUNT
	<i>Shelving Cont'd</i>				
A	25mm block board doors including 10 x 20mm Lipping tongued to edge of blockboard including groove to approval	12	SM		
B	40 x 40 x 3 mm mild steel angle lines screwed to wall/ column to approval	40	LM		
C	50 mm heavy duty butt hinges	36	Prs		
D	38mm Diameter dished knob	36	No		
E	50mm Extruded brass double ball catch to approved sample	36	No		
	Carried to collection				
	<p><u>COLLECTION</u></p> <p><u>FIXTURES AND FITTINGS</u></p> <p>Brought forward from page BL/17</p> <p>Brought down from page BL/18 above</p>				
	TOTAL FOR FIXTURES AND FITTINGS CARRIED TO SUMMARY				

PROPOSED CONSTRUCTION OF CLIMATE CHANGE INFORMATION CENTRE OFFICE
DEVELOPMENT IN SOKONI WARD - KILIFI MUNICIPALITY

ITEM	DESCRIPTION	QTY	UNIT	RATE	AMOUNT
	<u>ELEMENT NO.10</u>				
	<u>FINISHES</u>				
	INTERNAL FINISHES				
	Floor finishes				
	Screed; cement and sand 1:4 with approved integral dust proofing additive wood floated.				
A	32 mm thick to receive non-slip ceramic tiles(m.s)	1,263	SM		
B	Ditto suspended landing	9	SM		
C	Ditto 300mm wide treads	66	LM		
D	Ditto 150mm high risers	66	LM		
	Non-slip ceramic tiles				
	Note: Works on tiles shall commence after sample tile is approved.				
E	8mm thick non-slip ceramic tiles fixed with tile adhesive, all to approval	1,272	SM		
F	100mm high ditto skirting	626	LM		
G	Ditto 300mm wide treads	66	LM		
H	Ditto 150mm high risers	66	LM		
	<u>Ceiling Finishes</u>				
	15 mm Thick internal gauged lime plaster as described to:				
I	Soffits of suspended slabs	1,263	SM		
J	Soffits of suspended slab above staircase	23	SM		
K	Ditto to soffits of landing	9	SM		
L	Ditto to soffits of staircase	22	SM		
	Carried to collection				

PROPOSED CONSTRUCTION OF CLIMATE CHANGE INFORMATION CENTRE OFFICE
DEVELOPMENT IN SOKONI WARD - KILIFI MUNICIPALITY

ITEM	DESCRIPTION	QTY	UNIT	RATE	AMOUNT
	Wall Finishes				
	12mm thick cement sand (1:3) plaster steel trowelled smooth to:				
A	Walls and columns internally	1,502	SM		
B	Ditto beams	200	SM		
C	Door and window reveals	276	LM		
	Backing; cement and sand 1:4 with approved integral dust proofing additive wood floated.				
D	15 mm thick to receive ceramic tiles	276	SM		
	Glazed wall tiles, local approved colour; glazed; to regular pattern bedding and jointing in cement mortar (1:4). Grouting joints with matching colour cement				
E	400 x 250 x 6mm coloured ceramic tiles to wall surfaces	276	SM		
F	PVC Edgings	100	LM		
	EXTERNAL FINISHES				
G	15mm thick cement sand (1:3) render to walls and columns externally	988	SM		
H	Ditto beams	300	SM		
I	Door and window reveals	620	LM		
	Carried to collection				

PROPOSED CONSTRUCTION OF CLIMATE CHANGE INFORMATION CENTRE OFFICE
DEVELOPMENT IN SOKONI WARD - KILIFI MUNICIPALITY

ITEM	DESCRIPTION	QTY	UNIT	RATE	AMOUNT
	<p><u>COLLECTION</u></p> <p><u>FINISHES</u></p> <p>Brought forward from page BL/19</p> <p>Brought forward from page BL/20</p>				
	TOTAL FOR FINISHES CARRIED TO SUMMARY				

PROPOSED CONSTRUCTION OF CLIMATE CHANGE INFORMATION CENTRE OFFICE
DEVELOPMENT IN SOKONI WARD - KILIFI MUNICIPALITY

ITEM	DESCRIPTION	QTY	UNIT	RATE	AMOUNT
	<u>ELEMENT NO.11</u>				
	<u>PAINTING AND DECORATION</u>				
	<u>Internal Painting</u>				
	Prepare and apply three coats PVA based premium quality silk vinyl Anti Bacteria emulsion paint or other equal and approved to:-				
A	Plastered wall surfaces	1,502	SM		
B	Ditto beam surfaces	200	SM		
C	Soffits of suspended slabs	1,263	SM		
D	Ditto to soffits of landing	9	SM		
E	Ditto to soffits of staircase	22	SM		
F	Plastered door and window reveals	276	LM		
	<u>External Painting</u>				
	Prepare and apply three coats of Permaplast paint as "Crown Berger Limited" or any equal and approved to:				
G	Rendered wall surfaces	988	SM		
H	Ditto beam surfaces	300	SM		
I	Door and window reveals	620	LM		
	TOTAL FOR PAINTING AND DECORATION CARRIED TO SUMMARY				

PROPOSED CONSTRUCTION OF CLIMATE CHANGE INFORMATION CENTRE OFFICE
DEVELOPMENT IN SOKONI WARD - KILIFI MUNICIPALITY

ITEM	DESCRIPTION	QTY	UNIT	RATE	AMOUNT
	<u>SUMMARY</u>				
1	SUBSTRUCTURES				
2	R.C. SUPERSTRUCTURE				
3	SUPERSTRUCTURE WALLING				
5	ROOFING AND RAINWATER DISPOSAL				
6	DOORS				
7	WINDOWS				
8	BALUSTRADES & RAILINGS				
9	FIXTURES AND FITTINGS				
10	FINISHES				
11	PAINTING AND DECORATION				
	TOTAL FOR BUILDER'S WORKS CARRIED TO GRAND SUMMARY				

ELECTRICAL WORKS

PROPOSED CONSTRUCTION OF CLIMATE CHANGE INFORMATION CENTRE OFFICE DEVELOPMENT
IN SOKONI WARD - KILIFI MUNICIPALITY

ITEM	DESCRIPTION	QTY	UNIT	RATE	AMOUNT
	<u>SCHEDULE 1:</u>				
	<u>Supply Install, Test and Commission Following:-</u>				
	<u>LIGHTING POINTS</u>				
1.01	Lighting points wired in 3x1.5mm ² PVC/SC copper cables drawn in concealed 20mm diameter heavy gauge PVC conduit including all boxes, saddles and accessories for				
	i)One way switching	64	No.		
	ii)Two Way switching	12	No.		
1.02	10A moulded ivory type switch plates as MK range/clipsal or approved equivalent as follows				
	a)One gang one way	64	No.		
	b)One gang Two way	12	No.		
	d)Two gang One way	12	No.		
	e)Three gang One way	6	No.		
	<u>LIGHTING FITTINGS</u>				
1.03	Light fittings complete with all the necessary fixing accessories and rated energy lamps as follows:-				
	i)1200mm 1x36w batten Fluorescent fitting as FITZGERALD, THORN or approved equivalent (Type B1)	56	No.		
	ii)100w tungsten bulk head fitting as approved by the respective Engineer	24	No.		
	ii) Type S1-mirror strip light with ON/OFF pull chord, 240/110V ac socket suitable for wet areas cw 60w strip light as micromark or approved equivalent	8	No.		
	iii)60w spherical screw neck ball fitting as THORN MTC 1060 or as approved equivalent (Type 1)	24	No.		
	ix)1x8w non-maintained emergency lighting type flourescent bulkhead as THORN Cat. No. EFV M3.T/ICEL	6	No.		
	v)Ceiling mounted standard circular luminaire with opal diffuser and white polycarbonate body with HPF control gear for 16w/2D lamp as THORN OYSTER 23 ROUND or approved equivalent	30	No.		
	TOTAL C/F TO COLLECTION				

PROPOSED CONSTRUCTION OF CLIMATE CHANGE INFORMATION CENTRE OFFICE DEVELOPMENT
IN SOKONI WARD - KILIFI MUNICIPALITY

ITEM	DESCRIPTION	QTY	UNIT	RATE	AMOUNT
<u>SOCKET OUTLETS AND POWER POINTS</u>					
1.04	Socket outlet point comprising wiring in 3x2.5 mm ² PVC-SC-Cu cables drawn inside 20mm diameter HG conduits	56	No.		
1.05	13A Twin switched moduled socket outlet plate as crabtree or approved equivalent:-	56	No.		
1.08	3 compartment floor box recessed in floor for twin socket outlets and data points BRITON make as CRABTREE Cat. No. BRS 3G	16	No.		
1.07	13A Twin switched waterproof socket outlet plate as CRABTREE Cat. No/ 9565/LX IP 65 or approved equivalent	2	No.		
<u>ELECTRICAL SWEEP FANS</u>					
1.09	Ceiling fan points wired in 3x1.5mm ² PVC/SC copper cables drawn in concealed 20mm diameter heavy gauge PVC conduit including all boxes, saddles and all accessories	30	No.		
1.10	1400mm 3-arm Ceiling fan as ORIENT DELUXE complete with the regulator or approved equivalent	30	No.		
1.11	Ceiling fan hook (M-10)	30	No.		
<u>SUB-MAINS CABLES</u>					
1.12	5x16.0mm ² SC-PVC copper cables drawn inside 38mm diameter HG conduits	40	No.		
1.13	14 gauge (14 s.w.g.) galvanized mild steel 'T' cable looping box to M.O.W standards	1	No		
1.14	60/80A Twin Lucy cut-out with neutral link	1	No		
1.15	60/80A single Lucy cut-out	2	No		
1.16	Hand drier point comprising wiring in 3x2.5 mm ² PVC-SC-Cu cables drawn in 25mm diameter HG conduits including all boxes, sanddles and accessories	7	No.		
<u>POWER POINT FOR AIR CONDITIONING UNITS</u>					
1.17	Air conditioner points wired using 3x4.0mm ² SC PVC Cu cables drawn in HG PVC conduits/PVC trunking	24	No.		
1.18	15A 3-pin One gang SP switched flush socket outlet as MEM or approved equivalent	24	No.		
TOTAL C/F TO COLLECTION					



PROPOSED CONSTRUCTION OF CLIMATE CHANGE INFORMATION CENTRE OFFICE DEVELOPMENT
IN SOKONI WARD - KILIFI MUNICIPALITY

ITEM	DESCRIPTION	QTY	UNIT	RATE	AMOUNT
	<u>TV POINT</u>				
1.19	TV cord outlet points in 25mm diameter conduits interlinked and connected to a master antenna through a low loss coaxial cable or approved equivalent	12	No.		
1.20	Moulded TV outlet plate as MK or approved equivalent	12	No.		
	<u>DISTRIBUTION BOARDS</u>				
1.21	12-Way SPN Distribution Board flush mounted on the wall complete with 100A SPN integral isolator as CRABTREE or equivalent to approval.	1	No.		
1.22	Ditto but 9 ways	1	No.		
1.23	A standard metal clad looping box to Electrical Engineer's specification	1	No.		
1.24	SP MCB's as CRABTREE				
	i)10A SP	2	No.		
	ii)20A SP	3	No.		
	iii)32A SP	7	No.		
	iv)Blanking Plate	2	No.		
1.25	Sub-main power wired in 3x10.0mm ² PVC/SC copper cables drawn in concealed 25mm diameter heavy gauge PVC conduit complete with all necessary accessories excluding switches.	25	LM		
1.26	14 gauge (14 swg) oven baked galvanized mild steel standard 'T' cable loop-in box to house 2 No. single cut-outs and 1No. Double cut-out	1	No		
	<u>FIRE ALARM</u>				
1.27	Fire alarm panel/Fire alarm bell/Break glass Unit Points/Smoke detector/heat detector points comprising wiring in 3x2.5mm ² fire resistant cables concealed in PVC conduits concealed in ceiling space but excluding bell and break glass unit	4	No		
1.28	Call point as MENVIER or approved equivalent	4	No		
1.29	Sounder as MENVIER or approved equivalent	2	No		
1.30	Smoke/Heat detectors complete with base as MENVIER MPD + MDB 700	4	No		
	TOTAL C/F TO COLLECTION				



MECHANICAL WORKS

PROPOSED CONSTRUCTION OF CLIMATE CHANGE INFORMATION CENTRE OFFICE DEVELOPMENT
IN SOKONI WARD - KILIFI MUNICIPALITY

ITEM	DESCRIPTION	QTY	UNIT	RATE	AMOUNT
	<p><u>SPECIFICATIONS AND BILLS OF QUANTITIES FOR THE PROPOSED INTERNAL PLUMBING, SANITARY FITTINGS, DRAINAGE, WATER RETICULATION, AND PORTABLE FIRE FIGHTING EQUIPMENTS INSTALLATIONS FOR THE PROPOSED CONSTRUCTION OF CLIMATE CHANGE INFORMATION CENTRE OFFICE DEVELOPMENT</u></p> <p>1). Plumbing, Sanitary fittings and Drainage</p> <p>2) Water Tanks installations, Pumping and treatment plants</p> <p>3). Refrigeration, Air Conditioning and Mechanical Ventillation</p> <p>4). Fire Engineering Services</p>				
	TOTAL CARRIED TO COLLECTION				

PROPOSED CONSTRUCTION OF CLIMATE CHANGE INFORMATION CENTRE OFFICE DEVELOPMENT
IN SOKONI WARD - KILIFI MUNICIPALITY

ITEM	DESCRIPTION	QTY	UNIT	RATE	AMOUNT
	<p>Supply, deliver and install pipes, tubing and fittings as described and shown on the drawings. The pipes shall be PN 25PPR pipes where exposed to adverse weather conditions and all conforming to the current European standards for PPR installations and to the Engineers Approval. Pipe jointing shall be by polyfusion or use electric coupling, Rates must allow for all metal/plastic threaded adaptors where required for the connection of sanitary fixtures, valves, sockets, sliding and fixed joints support raceways, isolating sheaths, elastic materials, expansion arms and bends cross overs, couplings, clippings, connectors, joints etc. as required in the running legths of pipe work and also where necessary, for pipe fixing clips, holder bats plugged and screwed for the proper and satisfactory functioning of the system. The pipes will be pressure tested before the plastering of wall commences and as per the manufactures recommended testing pressures</p> <p><u>ELEMENT NO. 1 (INTERNAL PLUMBING):</u></p> <p><u>PPR Pipes</u></p>				
A	20mm diameter (PN-20) PPR pipe in chase	60	LM		
B	25mm Ditto	64	LM		
C	32mm Ditto	32	LM		
D	40mm Ditto	50	LM		
E	50mm Ditto	4	LM		
	TOTAL CARRIED TO COLLECTION				

PROPOSED CONSTRUCTION OF CLIMATE CHANGE INFORMATION CENTRE OFFICE DEVELOPMENT
IN SOKONI WARD - KILIFI MUNICIPALITY

ITEM	DESCRIPTION	QTY	UNIT	RATE	AMOUNT
	<u>ELEMENT NO.1 CONT'D:</u>				
	<u>Sockets</u>				
A	20mm diameter socket	16	No.		
B	25mm ditto	28	No.		
C	32mm ditto	24	No.		
D	40mm ditto	3	No.		
E	50mm ditto	2	No.		
	<u>Bends</u>				
F	20mm diameter bends	16	No.		
G	25mm ditto	28	No.		
H	32mm ditto	29	No.		
I	40mm ditto	2	No.		
J	50mm ditto	1	No.		
	<u>Tees</u>				
K	20mm diameter equal tees	16	No.		
L	25mm ditto	8	No.		
M	32mm ditto	12	No.		
N	40mm ditto	1	No.		
O	50mm ditto	1	No.		
	TOTAL CARRIED TO COLLECTION				

PROPOSED CONSTRUCTION OF CLIMATE CHANGE INFORMATION CENTRE OFFICE DEVELOPMENT
IN SOKONI WARD - KILIFI MUNICIPALITY

ITEM	DESCRIPTION	QTY	UNIT	RATE	AMOUNT
	<u>ELEMENT NO.1 CONT'D:</u>				
	<u>Reducers</u>				
A	25x20mm Reducer	28	No.		
B	32x20mm Reducer	12	No.		
C	32x25mm Ditto	8	No.		
D	40x25mm Ditto	6	No.		
E	40x32mm Ditto	2	No.		
F	50x32mm Ditto	1	No.		
G	50x40mm Ditto	1	No.		
	<u>Threaded Fittings</u>				
H	20mm diameter male/female threaded 90° bend/Elbow	64	No.		
I	25mm diameter PPR-M Adapter	18	No.		
J	32mm ditto	6	No.		
K	40mm ditto	6	No.		
	<u>Nipples</u>				
L	20mm diameter G.I Nipple	24	No.		
M	25mm ditto	6	No.		
N	32mm ditto	6	No.		
	TOTAL CARRIED TO COLLECTION				

PROPOSED CONSTRUCTION OF CLIMATE CHANGE INFORMATION CENTRE OFFICE DEVELOPMENT
IN SOKONI WARD - KILIFI MUNICIPALITY

ITEM	DESCRIPTION	QTY	UNIT	RATE	AMOUNT
	<u>ELEMENT NO.1 CONT'D:</u>				
	<u>Valves</u>				
A	20mm diameter approved medium pressure screw down full way non-rising stem wedge gate valve to BS 5154 PN 20 for series B rating,with wheel and head jopints to steel tubing and complete with round male threaded transtion fittings.The gate valve to be as PEGLER or approved equivalent.	4	No.		
B	25mm Ditto	2	No.		
C	32mm Ditto	2	No.		
TOTAL CARRIED TO COLLECTION					
	<u>Summary of Collection:</u>				
	<u>Internal Plumbing</u>				
	Totals Brought Down From Above				
	Totals Brought Forward From Mech/2				
	Totals Brought Forward From Mech/3				
	Totals Brought Forward From Mech/4				
TOTAL INTERNAL PLUMBING CARRIED FORWARD TO MECHANICAL WORKS SUMMARY PAGE					

PROPOSED CONSTRUCTION OF CLIMATE CHANGE INFORMATION CENTRE OFFICE DEVELOPMENT
IN SOKONI WARD - KILIFI MUNICIPALITY

ITEM	DESCRIPTION	QTY	UNIT	RATE	AMOUNT
	<p><u>ELEMENT NO. 2:</u></p> <p><u>SANITARY FITTINGS:</u> Supply,deliver,install,test and commission the following sanitary appliances complete with all the accessories including all connections to the services,waste,jointing to water supply,overflows,supports and all plugging and screwing to walls and floors.</p> <p><u>Note.</u> (i). All sanitary fittings shall be in approved colour. (ii). The model and Ref. No. Indicated is only a guide to the type and quality of fittings. (iii). Equivalent and Approved models may be acceptable</p> <p><u>Close Couple Water Closet</u></p>				
A	Close Couple water closet suite in approved colour comprising of W.C. bowl,'p'or's' trap connector,heavy duty matching plastic seat and cover with metal top fixed to (crome plated) hinges and secured to floor or wall and complete with horizontal outlet to BS 3402 with 9 litre valveless Top Quality Ceramic Cistern and fittings including siphon,15mm diameter side inlet ball valves,20mm diameter side overflow,plastic flush bend,inlet connection,and chrome-plated lever..The water closet suite to be as 'Model Twyford's'-England or other approved equivalent.	16	No		
B	<p><u>Toilet Roll Holder</u></p> <p>Semi recessed toilet roll holder in Vitreous China of size 165 x 165mm in approved colour as Twyford's 9806WH or equal and approved.</p>	16	No.		
C	<p><u>Bib Tap</u></p> <p>15mm diameter heavy duty 'Peglar' bib tap or other equal and to approved catalogue</p>	7	No		
	TOTAL CARRIED TO COLLECTION				

PROPOSED CONSTRUCTION OF CLIMATE CHANGE INFORMATION CENTRE OFFICE DEVELOPMENT
IN SOKONI WARD - KILIFI MUNICIPALITY

ITEM	DESCRIPTION	QTY	UNIT	RATE	AMOUNT
	<u>ELEMENT NO.2 CONT'D:</u>				
	<u>Hand Drier</u>				
A	Automatic Hand Drier in approved colour operating on infra-red automatic sensing system with heating element,safety cut-out complete with a 30-seconds safety timer,plastic rawl plugs and fixing screws.The hand drier to have a heating capacity of 3.1Kw and performance flow rate of 3.82 Litres/Min and to be of size 270x264x143mm deep.It shall have a noise level of below72.5dBA at 1.5m.It shall be as 'Model Mediclinics' or other approved equivalent	7	No		
	<u>Mirrors</u>				
B	610 X 610mm X 6mm thick polished plate silver backed with beveled edges mirror fixed with clear silicon to 100 x 25mm thick wrot mahogany molded framing in 4 labors plugged to wall using 4No. Wall plugs with 75mm long stainless steel screws, painted in three coats polyurethane varnish all to approval	12	No		
	<u>Flexible Tubing</u>				
C	15mm diameter x 300mm longg flexible connectors complete with Integral chrome plated angle valve for connecting the Sanitary fitting to water supply.To be as Cobra or equal and approved.	30	No.		
	<u>Counter Top Wash Hand Basin</u>				
D	Wash Hand Basin suitable for mounting on counter size 510x420mm with one tap holes and chain stay hole,32 mm diameter chrome-plated pop up chain waste,first quality plastic bottle bottle trap(32mm 'P' trap) with 75mm seal.The wash hand basin to be as 'Model Twyfords' Sola 510'or equal and approved.The basin to be supplied and installed complete with 15mm diameter heavy duty chrome plated single lever basin mixer ' COBRA' elbow action Pillar Tap or other equal and approved	12	No		
	TOTAL CARRIED TO COLLECTION				

PROPOSED CONSTRUCTION OF CLIMATE CHANGE INFORMATION CENTRE OFFICE DEVELOPMENT
IN SOKONI WARD - KILIFI MUNICIPALITY

ITEM	DESCRIPTION	QTY	UNIT	RATE	AMOUNT
	<u>ELEMENT NO.2 CONT'D:</u>				
	<u>Semi Pedestal Wash Hand Basin</u>				
A	Wash Hand Basin with semi - pedestal, size 510x420mm with one tap hole and chain stay hole,32 mm diameter chrome-plated pop up chain waste and fittings,approved first quality plastic bottle trap(32mm bottle trap) with 75mm seal.The wash hand basin to be as 'Model Twyfords 'Sola 510'or equal and approved.The basin to be supplied and installed complete with 15mm diameter heavy duty chrome plated single lever basin mixer ' COBRA ' elbow action Pillar Tap or other equal and approved	4	No		
	<u>Shower Fittings</u>				
B	Concealed shower fitting consisting of 25mm diameter x 2500mm long PPR riser pipe for showers,25mm diameter chrome plated cold water swivel/adjustable shower rose, Carina handle and 2No. 'Cobra' Stop Cocks	2	No.		
	<u>Urinal Set</u>				
C	Urinal system comprising of 1No. Ceramic ' DURAVIT ' urinal bowl and division or equal and approved complete with doomed waste fitting all to approval, Exposed push button-Type Urinal Flush Valve for 3/4" top spud urinals as 'COBRA' or other approved equivalent including fixing to wall with steel screws brackets and accessories for proper functioning of the set	4	SET		
	<u>Soap Dispenser</u>				
D	Wall mounted soap dispenser with a capacity of about 1.5 Litre and having a press action soap release mechanism complete with fixing screws.including allowing for initial soap supply as 'Starmix or other approved equivalent.The soap dispenser shall be size125x100x290mm high and shall be as ' Model Mediclinics ' or other approved equivalent	8	No		
	TOTAL CARRIED TO COLLECTION				

PROPOSED CONSTRUCTION OF CLIMATE CHANGE INFORMATION CENTRE OFFICE DEVELOPMENT
IN SOKONI WARD - KILIFI MUNICIPALITY

ITEM	DESCRIPTION	QTY	UNIT	RATE	AMOUNT
	<p><u>ELEMENT NO.2 CONT'D:</u> <u>Disabled persons Water Closet and Wash Hand Basin Facility</u> Wheel chair accessible W.C facility Comprising of the following:-</p>				
A	<p>(i)Close coupled W.C with 7.5 litre cistern with bottom inlet and overflow.The bowl shall e of size 375 x 560 x 420mm high.The bowl and cistern shall be manufactured from vitreous china complying with B.S 3402.The unit shall be complete with valveless cistern fitting including syphon,15mm side inlet ball valve,20mm diameter side overflow,plastic flush bend,inlet connector and reversible metallic chrome plated cistern lever.There shall also be a heavy duty seat(25mm high) and cover with chrome plated metal hinges,toilet roll holder,900 x 450 x 6mm thick mirror and Robe hook(ii)Semi-recessed wall mounted W.H.B of size 600 x 500 x 545mm high with flexible connectors to water taps.The basin shall be manufactured from vitreous china complying with B.S 3402.It shall have one L/H tap hole with 15mm chrome plated lever action pillar tap,chrome plated waste,first quality bottle trap,pedestal and wall fixing bolts.</p> <p>(iii)Hinged support rail with toilet roll holder 770mm long manufactured in nylon coated aluminium and mounted on a wall fixing plate size 230x100mm,4No. 600mm grab rails with covered wall plates.The Disabled set shall be as Twyforde-England-DOC.M wheelchair accessible W.C facility or approved equivalent.</p>	2	SET		
B	<p><u>Soap dish</u> Semi recessed built in soap dish in vitreous china of size 150x150mm in approved colour as Twyforde or equal and approved .</p>	2	No.		
TOTAL CARRIED TO COLLECTION					

PROPOSED CONSTRUCTION OF CLIMATE CHANGE INFORMATION CENTRE OFFICE DEVELOPMENT
IN SOKONI WARD - KILIFI MUNICIPALITY

ITEM	DESCRIPTION	QTY	UNIT	RATE	AMOUNT
	<u>ELEMENT NO.2 CONT'D:</u>				
A	<u>Towel Rail</u> Chrome plated 20mm diameter x 800mm long approved towel rail and brackets as one piece, plugged and screwed into the wall. The fitting ball shall be as Twyfords or equal and approved.	2	No		
	TOTAL CARRIED TO COLLECTION				
	<u>Summary of collection</u> <u>Sanitary Fittings</u> Totals Brought Forward From Mech/6 Totals Brought Forward From Mech/7 Totals Brought Forward From Mech/8 Totals Brought Forward From Mech/9 Totals Brought Forward From Mech/10				
	TOTAL SANITARY FITTINGS CARRIED FORWARD TO MECHANICAL WORKS SUMMARY PAGE				

PROPOSED CONSTRUCTION OF CLIMATE CHANGE INFORMATION CENTRE OFFICE DEVELOPMENT
IN SOKONI WARD - KILIFI MUNICIPALITY

ITEM	DESCRIPTION	QTY	UNIT	RATE	AMOUNT
	<p><u>ELEMENT NO.3:</u></p> <p><u>FOUL DRAINAGE:</u></p> <p>Supply,deliver and install the following UpVC,MUpVC,soil and waste systems,respectively to B.S 5255 with fittings fixed Key Terrain High Grade Golden Brown and Grey UPVC soil and waste pipe and jointing in accordance with manufacture's printed instructions and manufactured by reputable manufacturers.Tenderers must allow in their pipework prices for all the couplings,clippingsconnectors,joints,e.t.c as required in the running lengths of pipework and also where necessary,for pipe fixing clips,holder bats plugged and screwed for the proper and satisfactory functioning of the system</p> <p><u>Internal:</u></p>				
A	40mm diameter Grey UPVC waste pipe in wall chase.	30	LM		
B	50mm ditto	40	LM		
C	40mm ditto but boxed in concrete floor slab	40	LM		
D	50mm ditto	48	LM		
E	100mm ditto but in wall duct	60	LM		
	<u>Extra Ovetubing For:-</u>				
F	100x50mm diameter UPVC floor trap,grating and cover	10	No		
G	100x50x40mm diameter Master gulley floor trap ditto	6	No		
H	100mm diameter WC connector	16	No		
	TOTAL CARRIED TO COLLECTION				

PROPOSED CONSTRUCTION OF CLIMATE CHANGE INFORMATION CENTRE OFFICE DEVELOPMENT
IN SOKONI WARD - KILIFI MUNICIPALITY

ITEM	DESCRIPTION	QTY	UNIT	RATE	AMOUNT
	<u>ELEMENT NO.3 CONT'D:</u>				
	<u>External;:</u>				
A	100mm diameter Grey UPVC soil vent pipe with expansion coupling and fixing to wall with holder bats ducts	64	LM		
B	100mm diameter Golden Brown UPVC waste pipe in soil	84	LM		
C	160mm ditto	12	LM		
	<u>Extra Overtubing For:-</u>				
D	40mm diameter access tee and cap	16	No		
E	50mm ditto	12	No		
F	100mm diameter Inspection bend and Acces cap.	16	No		
G	100mm diameter vent cowl	12	No		
H	100mm diameter weathering Slate and Apron	2	No		
I	100mm diameter medium duty UPVC gulley trap,grating cover and waste	16	No.		
	TOTAL CARRIED TO COLLECTION				
	<u>Summary of Collection:</u>				
	<u>Foul Drainage</u>				
	Totals Brought Down From Above				
	Totals Brought Forward From Mech/11				
	TOTAL FOUL DRAINAGE CARRIED FORWARD TO MECHANICAL WORKS SUMMARY PAGE				

PROPOSED CONSTRUCTION OF CLIMATE CHANGE INFORMATION CENTRE OFFICE DEVELOPMENT
IN SOKONI WARD - KILIFI MUNICIPALITY

ITEM	DESCRIPTION	QTY	UNIT	RATE	AMOUNT
	<p><u>ELEMENT NO.4:</u></p> <p><u>STERILIZATION AND TESTING:</u></p> <p>A Allow for sterilization and flushing out of entire cold water installation with chlorine to the Engineer's Satisfaction</p> <p>B Ditto for setting to work and testing the whole of the plumbing and drainage installation works both during progress and at completion to the satisfaction of the Engineer's satisfaction and to leave the whole installation in good working condition</p>	1	ITEM		
	TOTAL TESTING CARRIED FORWARD TO MECHANICAL WORKS SUMMARY PAGE				

PROPOSED CONSTRUCTION OF CLIMATE CHANGE INFORMATION CENTRE OFFICE DEVELOPMENT
IN SOKONI WARD - KILIFI MUNICIPALITY

ITEM	DESCRIPTION	QTY	UNIT	RATE	AMOUNT
	<u>ELEMENT NO.5:</u>				
	<u>BUILDER'S WORK IN CONNECTION WITH PLUMBING AND DRAINAGE</u>				
	<u>Masonry Gulley Trap</u>				
A	Construct masonry gulley trap size 200x200mm, approx depth 300mm, complete with seal and concrete cover, including all disposal and form work	16	No.		
	<u>Manholes and Covers</u>				
B	Construct Manholes size 600 x 450mm and averaging 750mm deep constructed in 100mm thick concrete base(1:3:6), approved 150mm block sides rendered all around in cement and sand (1:4).It shall have an approved heavy duty cast iron cover and frame as manufactured by E.A Foundry works,Including all necessary excavations,disposal and form work.	12	No.		
	<u>Excavations</u>				
C	Excavate trench not exceeding 1.5m deep, average depth 600mm for laying of drain pipes as earlier described, part back fill, part load and cart away remainder	96	LM		
	<u>Chasing</u>				
D	Form chase in both 100mm and 200mm thick coral block wall to receive necessary pipe work and make good disturbed areas	210	LM		
	<u>Holes</u>				
E	Make a hole through 200mm thick coral block wall for small pipe and make good disturbed areas	20	No.		
F	Ditto but large ditto	20	No.		
	TOTAL BUILDERS WORK CARRIED FORWARD TO MECHANICAL WORKS SUMMARY PAGE				

PROPOSED CONSTRUCTION OF CLIMATE CHANGE INFORMATION CENTRE OFFICE DEVELOPMENT
IN SOKONI WARD - KILIFI MUNICIPALITY

ITEM	DESCRIPTION	QTY	UNIT	RATE	AMOUNT
	<p><u>ELEMENT NO.6:</u></p> <p><u>WATER RETICULATION (ALL PROVISIONAL):</u></p> <p><u>WATER TANKS:</u></p> <p><u>Overhead Water Tank</u></p>				
A	Supply, deliver and install Cylindrical close end plastic moulded tank of capacity 5,000 litres and (size 1900mm diameter x 2000mm high). The tank to be assembled complete with cover and having screwed connections fo inlet, outlet, overflow, 32mm high pressure ball valve, drain pipes and any other item necessary for its proper functioning.The tank shall be as " Roto Model " or equal and approved	2	ITEM		
B	<p><u>Surface Mounted Water Storage Tank</u></p> <p>Supply, deliver and install vertical close end plastic moulded water storage tank of capacity 10,000 litres and (size 2400mm diameter x 2800mm high). The tank to be assembled complete with cover and having screwed connections fo inlet, outlet, overflow, 32mm high pressure ball valve, drain pipes and any other item necessary for its proper functioning.. The tank shall be installed on a reinforced flat surface platform base approx. 900mm high (M/S) and shall be as "Roto Model" or equal and approved</p>	1	ITEM		
C	<p><u>Tank Base</u></p> <p>Allow for the construction of the above mentioned tank base Approx.size 2500mm diameter x 900mm high consisting of 200mm thick coral block wall,100mm thick well compacted harcove filling,50mm thick blinding,Approved Damp proof membrane,A142 BRC Mesh,100mm thick vibrated (1:2:4)concrete floor slab, 15mm thick screed on the general faces of the tank base in (1:3) cement/sand mortar, 600mm widex1500mm deep srip foundation,including all Excavations and disposal</p>	1	ITEM		
	TOTAL CARRIED TO COLLECTION				

PROPOSED CONSTRUCTION OF CLIMATE CHANGE INFORMATION CENTRE OFFICE DEVELOPMENT
IN SOKONI WARD - KILIFI MUNICIPALITY

ITEM	DESCRIPTION	QTY	UNIT	RATE	AMOUNT
	<u>ELEMENT NO.06 CONT'D:</u>				
	<u>Testing</u>				
A	Allow for connecting the above earlier described Booster pumps to the pump delivery and suction lines, including Test Pumping and testing the whole of the water Reticulation system both during progress and at commissioning to the Engineer's satisfaction and to leave the system in and good sound working condition	1	ITEM		
	<u>Excavations</u>				
B	Excavate trench in soil/murram for Water Mains supply pipe not exceeding 1200mm deep ,lay pipe,part return in,fill ram and surplus cart away	200	LM		
	<u>Pipe Work</u>				
C	40mm diameter (PN-20) PPR Riser in duct and on roof terrace	8	LM		
D	25mm diameter PPR (PN-20) pipe drop in ducts	24	LM		
E	32mm ditto	24	LM		
F	40mm ditto	12	LM		
G	50mm ditto	12	LM		
H	40mm ditto but distribution pipework on roof terrace	36	LM		
I	50mm ditto	12	LM		
J	63mm ditto	24	LM		
K	50mm diameter (PN-20) PPR Pipe laid and jointed in trench	20	LM		
	TOTAL CARRIED TO COLLECTION				

PROPOSED CONSTRUCTION OF CLIMATE CHANGE INFORMATION CENTRE OFFICE DEVELOPMENT
IN SOKONI WARD - KILIFI MUNICIPALITY

ITEM	DESCRIPTION	QTY	UNIT	RATE	AMOUNT
	<u>ELEMENT NO.06 CONT'D:</u>				
	<u>Extra Overtubing for:</u>				
	<u>Sockets:</u>				
A	40mm diameter PPR Sockets	12	No.		
B	50mm ditto	4	No.		
C	65mm ditto	14	No.		
	<u>Bends</u>				
D	40mm diameter bend/Elbow	4	No.		
E	65mm ditto	2	No		
	<u>Tees</u>				
F	40mm diameter (PN-20) PPR equal tee	3	No.		
G	50mm ditto	1	No.		
H	65mm ditto	6	No.		
	<u>Valves</u>				
I	63mm diameter supply mains full way gate valve as PEGLAR or equal and approved	1	No.		
J	32mm diameter Non Return Valve as PEGLAR or equal and approved.	1	No.		
K	40mm ditto	1	No.		
	<u>Stand Pipe</u>				
L	15mm diameter bib tap suitable for connecting to a hose pipe complete with threaded adaptors.The tap to be complete with 5-metre long 20mm diameter pipe,bends,e.t.c.The chrome plated bib tap to be as 'cobra' Ref.107EC taps or other approved equivalent	1	ITEM		
	<u>Mains Valve Chamber</u>				
M	Construct Mains Valve Chamber size 600x600x500mm deep with 100mm thick concrete block rendered all round in cement and sand mortar (1:4) including hinged iron cover amd frame in grease	1	ITEM		
	TOTAL CARRIED TO COLLECTION				

PROPOSED CONSTRUCTION OF CLIMATE CHANGE INFORMATION CENTRE OFFICE DEVELOPMENT
IN SOKONI WARD - KILIFI MUNICIPALITY

ITEM	DESCRIPTION	QTY	UNIT	RATE	AMOUNT
	<u>ELEMENT NO.06 CONT'D:</u>				
	<u>Water connection and Testing</u>				
A	32mm diameter G.I. equal tee	1	No		
B	32x25mm diameter G.I. reducer	1	No		
C	25mm diameter G.I. nipple	2	No		
D	32mm diameter PPR Adaptor	1	No		
E	25mm diameter full Way gate valve as PEGLAR or other equal and approved	1	No		
	<u>Testing:</u>				
H	Allow for testing the general water supply and reticulation systems to level in sound working condition and to the Engineer's satisfaction	1	ITEM		
	TOTAL CARRIED TO COLLECTION				
	<u>Summary of Collection:</u>				
	<u>Water Reticulation</u>				
	Totals Brought Forward From Mech/15				
	Totals Brought Forward From Mech/16				
	Totals Brought Forward From Mech/17				
	Totals Brought Forward From Above				
	TOTAL WATER RETICULATION CARRIED FORWARD TO MECHANICAL WORKS SUMMARY PAGE				

PROPOSED CONSTRUCTION OF CLIMATE CHANGE INFORMATION CENTRE OFFICE DEVELOPMENT
IN SOKONI WARD - KILIFI MUNICIPALITY

ITEM	DESCRIPTION	QTY	UNIT	RATE	AMOUNT
	<p><u>ELEMENT NO.7 (FIRE FIGHTING AND PROTECTION SERVICES):</u></p> <p><u>PORTABLE FIRE EXTINGUISHERS</u></p> <p>Portable Fire Extinguisher</p>				
A	9Kg cartridge type general purpose portable dry powder fire extinguisher fully charged or equal and approved.	6	No.		
	<p>Carbon dioxide Gas Fire Extinguisher</p>				
B	5kg carbon dioxide gas portale fire extinguisher complete with pressure gauge,initial charge and mounting brackets	6	No.		
	<p>Dry Chemical Powder</p>				
C	6kg dry chemical powder portable fire extinguisher complete wth pressure gauge,initial charge and mounting brackets.	6	No.		
	<p><u>Signage</u></p>				
D	Allow for the signage, fire exits and fire instructions all as described in the particular specifications and to the Project Enginneer's Approval.	1	ITEM		
	<p><u>Testing</u></p>				
E	Testing the whole fire fighting equipments to leave in sound working condition and to the Engineer's satisfaction	1	ITEM		
	<p>TOTAL FIRE FIGHTING CARRIED FORWARD TO MECHANICAL WORKS SUMMARY PAGE</p>				

PROPOSED CONSTRUCTION OF CLIMATE CHANGE INFORMATION CENTRE OFFICE DEVELOPMENT
IN SOKONI WARD - KILIFI MUNICIPALITY

ITEM	DESCRIPTION	QTY	UNIT	RATE	AMOUNT
	<p><u>MECHANICAL WORKS SUMMARY PAGE:-</u></p> <p>INTERNAL PLUMBING BROUGHT FORWARD FROM MECH/5</p> <p>SANITARY FITTINGS BROUGHT FORWARD FROM MECH/10</p> <p>FOUL DRAINAGE BROUGHT FORWARD FROM MECH/12</p> <p>TESTING BROUGHT FORWARD FROM MECH/13</p> <p>BUILDERS WORK BROUGHT FORWARD FROM MECH/14</p> <p>WATER RETICULATION BROUGHT FORWARD FROM MECH/18</p> <p>FIRE FIGHTING SERVICES BROUGHT FORWARD FROM MECH/19</p>				
	<p>TOTAL FOR MECHANICAL WORKS CARRIED FORWARD TO GRAND SUMMARY</p>				

EXTERNAL WORKS

PROPOSED CONSTRUCTION OF CLIMATE CHANGE INFORMATION CENTRE OFFICE
DEVELOPMENT IN SOKONI WARD - KILIFI MUNICIPALITY

ITEM	DESCRIPTION	QTY	UNIT	RATE	AMOUNT
	<u>EXTERNAL WORKS</u>				
	<u>EXTERNAL SOIL WATER DRAINAGE (ALL PROVISIONAL):-</u>				
A	Excavate trench for drain pipe average 1500 mm deep, part return fill and ram and remainder cart away	100	LM		
B	Ditto average 3000 mm deep	50	LM		
C	300 mm diameter "Golden Brown" UPVC pipe laid in trench and jointed	150	LM		
D	600x450x1000mm (average) deep manholes complete with heavy duty cast iron manhole covers	15	NO		
E	Extra over for back filling with selected excavated material all to Project managers approval	90	CM		
	TOTAL OF EXTERNAL SOIL WATER DRAINAGE CARRIED TO ELEMENT SUMMARY				

PROPOSED CONSTRUCTION OF CLIMATE CHANGE INFORMATION CENTRE OFFICE
DEVELOPMENT IN SOKONI WARD - KILIFI MUNICIPALITY

ITEM	DESCRIPTION	QTY	UNIT	RATE	AMOUNT
	<u>SEPTIC TANK SITE 14 M LONG X 5M WIDE X 3M DEEP (2NO)</u>				
A	Clear site of shrubs,grass and carting away the arisings	102	SM		
B	Uprooting 300-600mm girth stumps	2	No.		
C	Excavate pit for septic tank not exceeding 1.5m deep	168	CM		
D	Ditto 1.5 - 3.0M deep	168	CM		
E	Ditto 3 - 4.5M deep	98	CM		
F	Extra over excavation in hard rock	20	CM		
G	Return fill and ram selected excavted soil around walling	63	CM		
H	Cart away surplus excavated material	273	CM		
I	50mm thick blinding 1:4:8	70	SM		
J	300mm thick reinforced concrete 1:2:4 slab in surface bed	70	SM		
K	Ditto in walls	123	SM		
L	150mm thick scum baffle	14	SM		
M	200mm thick in baffle wall	22	SM		
N	200mm thick cover slab	70	SM		
O	150mm thick scum buffle and dividing wall	7	SM		
	Carried to Collection				

PROPOSED CONSTRUCTION OF CLIMATE CHANGE INFORMATION CENTRE OFFICE
DEVELOPMENT IN SOKONI WARD - KILIFI MUNICIPALITY

ITEM	DESCRIPTION	QTY	UNIT	RATE	AMOUNT
	Sawn formwork: to				
A	Formwork to walling	246	SM		
B	Soffits of suspended slab	70	SM		
C	Sides of scum baffle wall	14	SM		
D	Ditto to sides and soffit of scum baffle	22	SM		
E	Box out formwork to opening size 600x450mm	4	NO		
	Steel reinforcement as described including cutting to length, bending, hoisting and fixing including all necessary tying wires and spacing blocks.				
	Ribbed bars to KS ISO 6935-2:2007				
F	10mm diameter high yield reinforcement bars	3,134	KG		
G	12mm ditto	1,696	KG		
H	8mm diameter mild-steel bars	226	KG		
I	Form or leave hole in 250mm concrete walling for 100mm pipe including making good disturbed surfaces	4	NO		
J	15mm sulphate resistant cement rendering internally	195	SM		
K	15mm thick cement/sand (1:3) waterproof screed to walls, top and soffit of cover slab and exposed surfaces of septic tank	165	SM		
L	30mm but surface bed slab internal floor screed finish	60	SM		
M	600x450mm heavy duty cast iron manhole cover and frame	4	NO		
N	600x450x1000mm average deep manholes	2	NO		
	Carried to collection				

PROPOSED CONSTRUCTION OF CLIMATE CHANGE INFORMATION CENTRE OFFICE
DEVELOPMENT IN SOKONI WARD - KILIFI MUNICIPALITY

ITEM	DESCRIPTION	QTY	UNIT	RATE	AMOUNT
	<p><u>SEPTIC TANK</u></p> <p>Brought forward from page EX/2</p> <p>Brought forward from page EX/3</p>				
	<p>TOTAL FOR 1NO. SEPTIC TANKS CARRIED TO ELEMENT SUMMARY</p>				

PROPOSED CONSTRUCTION OF CLIMATE CHANGE INFORMATION CENTRE OFFICE
DEVELOPMENT IN SOKONI WARD - KILIFI MUNICIPALITY

ITEM	DESCRIPTION	QTY	UNIT	RATE	AMOUNT
	<u>SOAK PIT - 2M DIAMETER X 12M DEEP - (1NO)</u>				
A	Excavate pit not exceeding 1.5M deep	5	CM		
B	Ditto exceeding 1.5M but not exceeding 3.0m deep	5	CM		
C	Ditto exceeding 3.0M but not exceeding 4.5M deep	5	CM		
D	Ditto exceeding 4.5M but not exceeding 6.0M deep	5	CM		
E	Ditto exceeding 6M but not exceeding 7.5M deep	5	CM		
F	Ditto exceeding 7.5M but not exceeding 9.0M deep	5	CM		
G	Ditto exceeding 9M but not exceeding 10.5M deep	5	CM		
H	Ditto exceeding 10.5M but not exceeding 12.0M deep	5	CM		
I	Extra-over excavation for excavating in rock	20	CM		
J	Cart away surplus excavated material from site	40	CM		
K	Plain concrete (1:3:6) in strip foundation	1	CM		
L	Reinforced concrete (1:2:4) in 100mm cover slab	5	SM		
	<u>Formwork To:-</u>				
M	Soffit of suspended slab	3	SM		
N	Edges of ditto 75 - 150mm high	8	lm		
O	Box out formwork to form opening size 600x450mm	1	NO		
	Carried to Collection				

PROPOSED CONSTRUCTION OF CLIMATE CHANGE INFORMATION CENTRE OFFICE
DEVELOPMENT IN SOKONI WARD - KILIFI MUNICIPALITY

ITEM	DESCRIPTION	QTY	UNIT	RATE	AMOUNT
A	10mm diameter high yield reinforcement bars	87	KG		
B	200mm coral blocks walling in cement sand (1:3) mortar	75	SM		
C	Approved hard-core backfill	21	CM		
D	Form or leave hole in 200mm coral block walling including making good disturbed surfaces	1	NO		
E	600 x 450mm cast iron manhole cover and frame	1	NO		
	<u>TESTING:-</u>				
F	Allow for testing the External soil drainage to the satisfaction of the Project Manager	1	ITEM		
	Carried to collection				
	<u>SOAK PIT</u> Brought forward from page EX/5 Brought down from above page EX/6				
	TOTAL OF SOAK PIT CARRIED TO ELEMENT SUMMARY				

PROPOSED CONSTRUCTION OF CLIMATE CHANGE INFORMATION CENTRE OFFICE
DEVELOPMENT IN SOKONI WARD - KILIFI MUNICIPALITY

ITEM	DESCRIPTION	QTY	UNIT	RATE	AMOUNT
	<u>SUMMARY</u>				
	<u>ELEMENT</u>				
1	External soil water drainage				
2	Septic Tank				
3	Soak pits				
	TOTAL FOR EXTERNAL WORKS CARRIED TO GRAND SUMMARY				

**PRIME COST SUMS AND
PROVISIONAL SUMS**

PROPOSED CONSTRUCTION OF CLIMATE CHANGE INFORMATION CENTRE OFFICE
DEVELOPMENT IN SOKONI WARD - KILIFI MUNICIPALITY

ITEM	DESCRIPTION	QTY	UNIT	RATE	AMOUNT
	<u>PRIME COSTS & PROVISIONAL SUMS</u>				
	<u>PROVISIONAL SUMS</u>				
	<u>The following provisional sums are to be measured on completion and priced in accordance with the rates contained in these bills of quantities or prorata thereto or deducted in whole if not required</u>				
A	Allow a provisional sum of Kenya shillings Three Million (3,000,000.00) only for Contingencies		ITEM		3,000,000.00
B	Allow a provisional sum of Kenya Shillings Five Hundred Thousand (Kshs. 500,000) only for installation of conduits for data networking, telephone and power circuits		ITEM		500,000
	<u>PRIME COST SUMS</u>				
C	Allow a prime cost sum for provision of KP&LC service line and attendance of Kenya Shillings Five Hundred Thousand only (Ksh. 500,000)		ITEM		500,000
D	Allow for contractor's profit		%		
	TOTAL FOR P.C. & PROVISIONAL SUMS CARRIED TO GRAND SUMMARY				



GRAND SUMMARY

**PROPOSED CONSTRUCTION OF CLIMATE CHANGE
INFORMATION CENTRE OFFICE DEVELOPMENT IN
SOKONI WARD - KILIFI MUNICIPALITY**

GRAND SUMMARY

ITEM	DESCRIPTION	FOR OFFICIAL USE ONLY	FOR TENDERER USE ONLY
		K.SHS.	K.SHS.
A	Particular Preliminaries		
B	General Preliminaries		
C	Builder's Works		
D	External Works		
E	Electrical Works		
F	Mechanical Works		
G	Provisional Sums	4,100,000.00	
	SUB-TOTAL		
	Add 16% VAT		
	Add 0.03% PPRA CAPACITY BUILDING LEVY		
	TOTAL CARRIED TO FORM OF TENDER		

Amount in words. Kenya shillings

.....

.....Cents

Tenderer's Signature and stamp.....

Address

Date

Witness Signature

Address

Date



NOTES

1. This drawing is to be read in conjunction with all other relevant Architectural/Structural drawings.
2. The Contractor to confirm all dimensions on site before commencing the works.
3. Figured dimensions only to be taken and all dimensions are in millimetres unless stated otherwise.
4. Structural Concrete to be class 20/20
Concrete cover to reinforcement including links;

Foundations = 50mm Columns = 40mm
Beams = 25mm Slabs/Stairs = 20mm

5. Reinforcement steel to be;

T- Ribbed high yield bars to BS 4461 and KS:ISO 6935-2
R-round mild bars to BS 4449.

6. All Reinforcement steel must be approved by the Structural Engineer before casting.

7. Foundation depth to be taken to firm ground. Minimum depth of foundation to be 1200mm.

8. All 200 mm thick walls to have Masonry of minimum strength of 7N/mm².

9. Foundation designed for a Ground Bearing Capacity of 100KN/M².

KEY TO FOUNDATION SECTION DETAILS

1. -Blinding concrete (1:4:8)
2. - 300mm Well Compacted Approved Hardcore (Compacted in 2 layers of 150mm)
3. - 50mm Murram Blinding
4. - 150mm Thick Slab
5. - A142 BRC Mesh placed 20mm from top.
6. - 1000mm Gauge Damp Proof Membrane (DPM)

REV	REVISIONS	SIGN	DATE	APPROVED
D	CHECKED			
C	CHECKED			
B	CHECKED			
A	CHECKED			

Client
COUNTY DIVISION OF CLIMATE CHANGE - FLOCCA PROGRAMME.

CHIEF OFFICER, ENVIRONMENT & CLIMATE CHANGE

Project
PROPOSED COUNTY CLIMATE CHANGE OFFICE BLOCK

Drawing Title
COLUMN REINFORCEMENT DETAILS

Designed by E. KAVIHA	Drawn by DKM
Checked by: Eng. GK	Approved by: G.KK



COLUMN C4 4 NO.
(Scale 1:25)

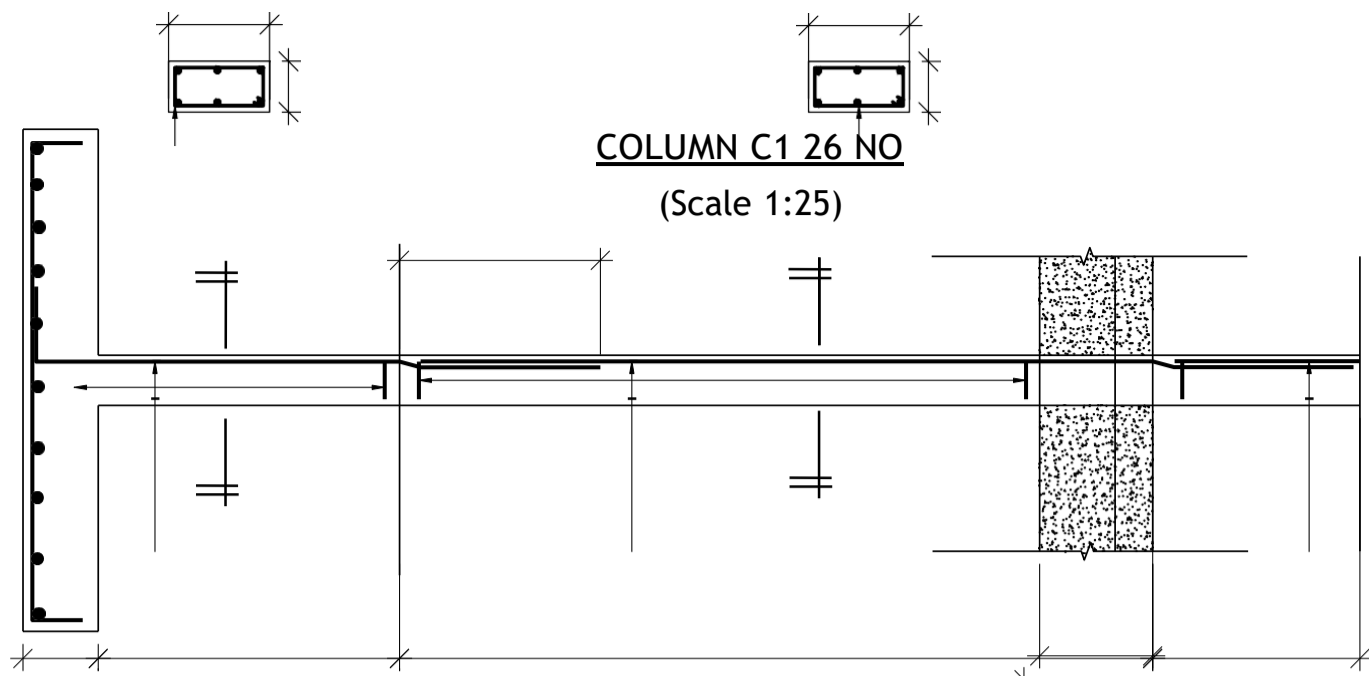

COLUMN C2 3 NO.
(Scale 1:25)

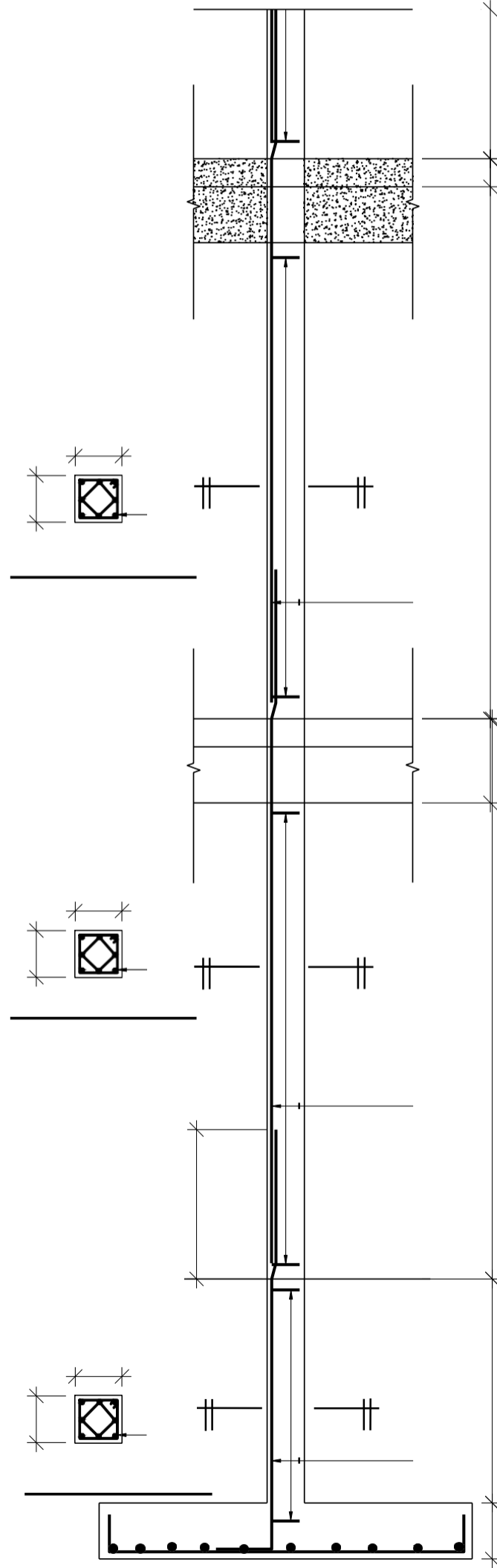

COLUMN C3 4 NO.
(Scale 1:25)

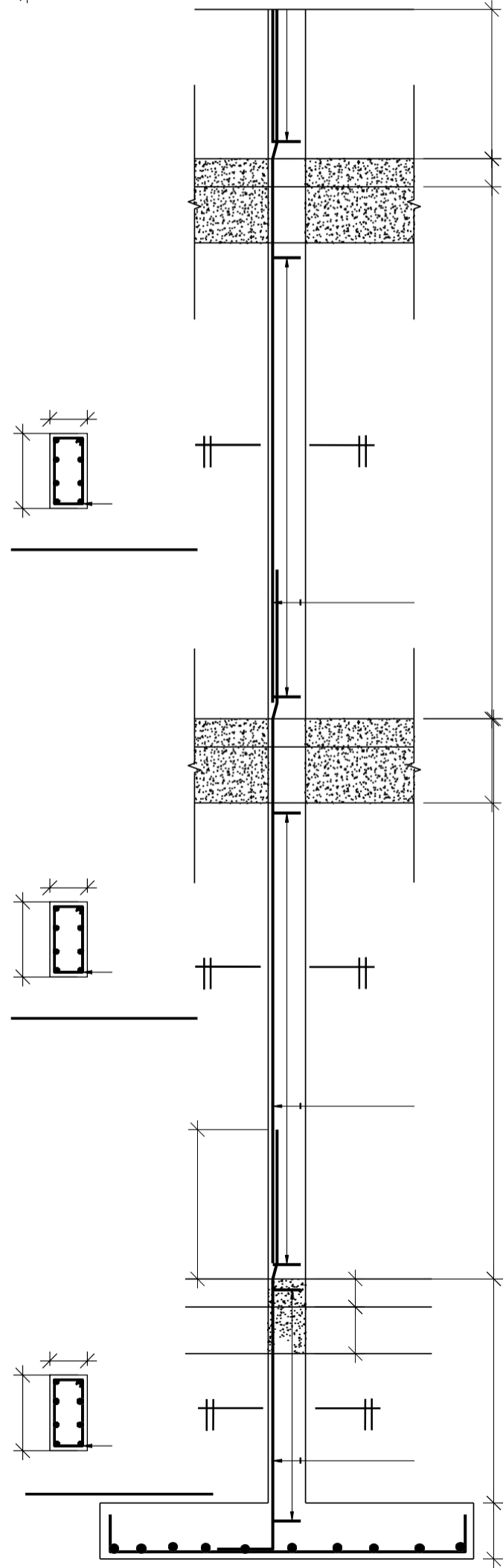
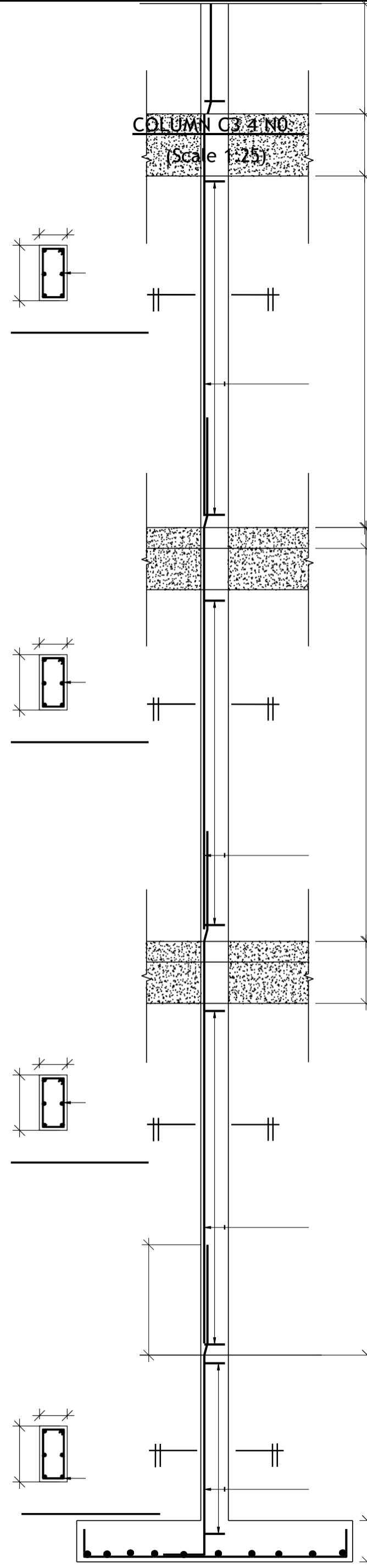

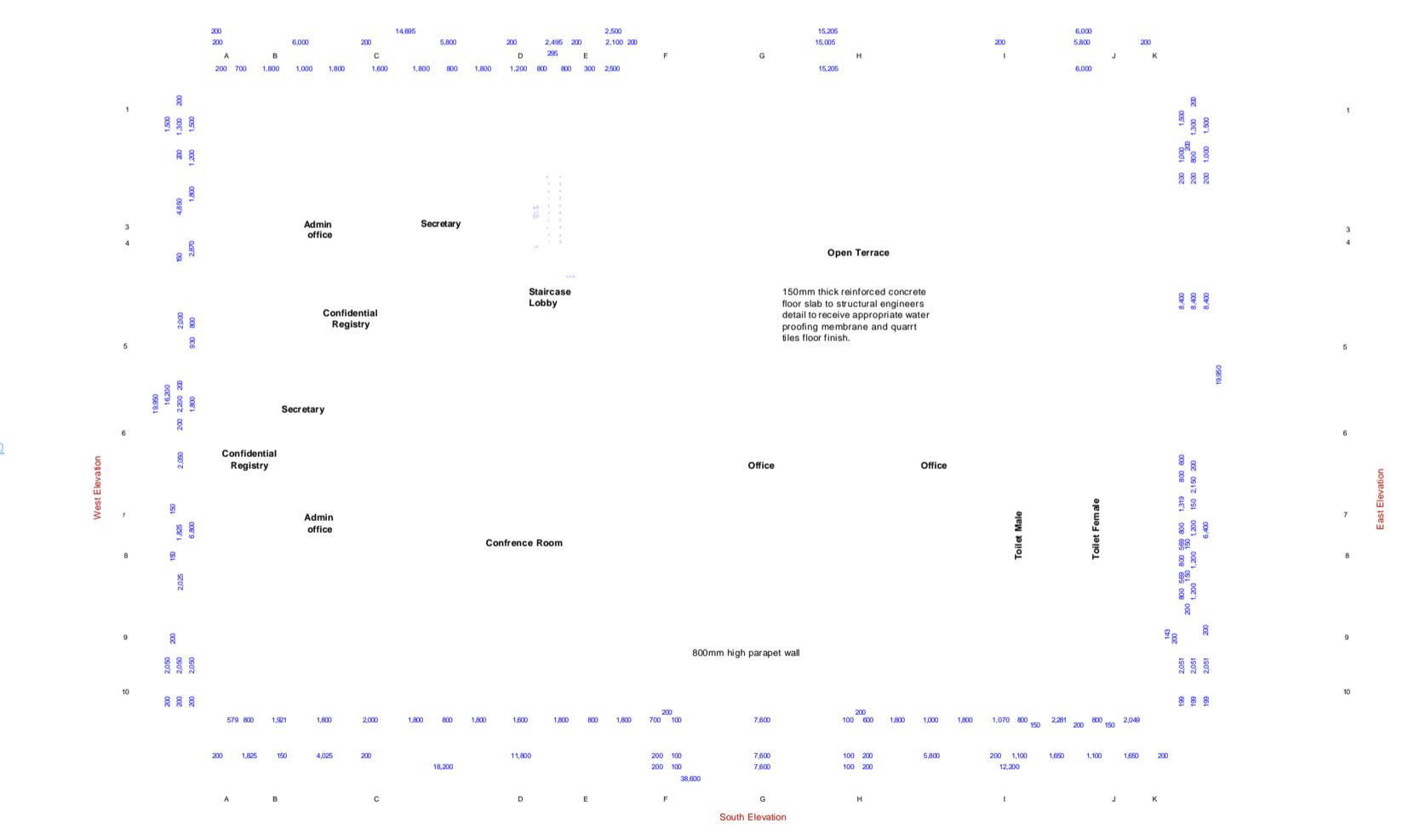
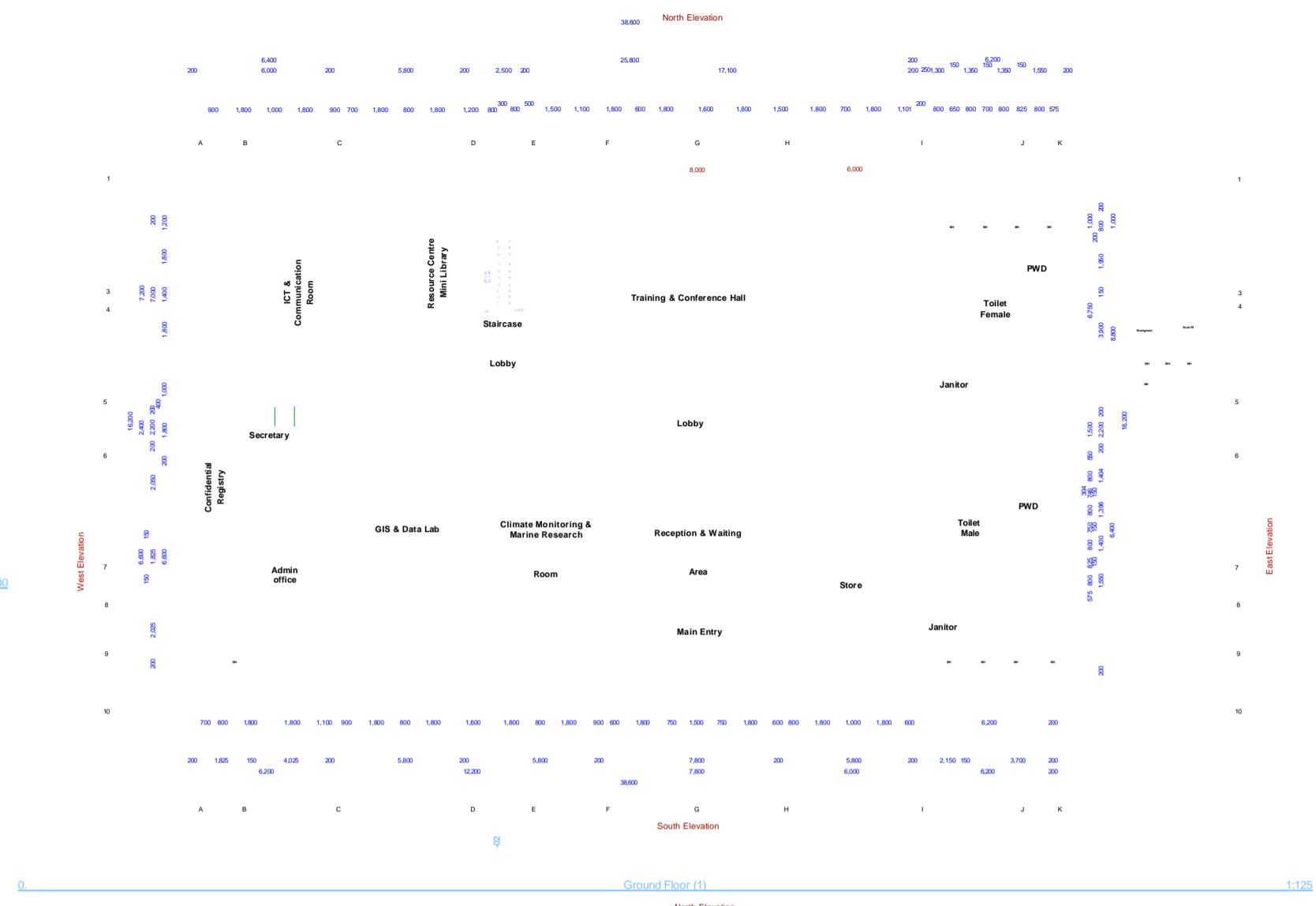
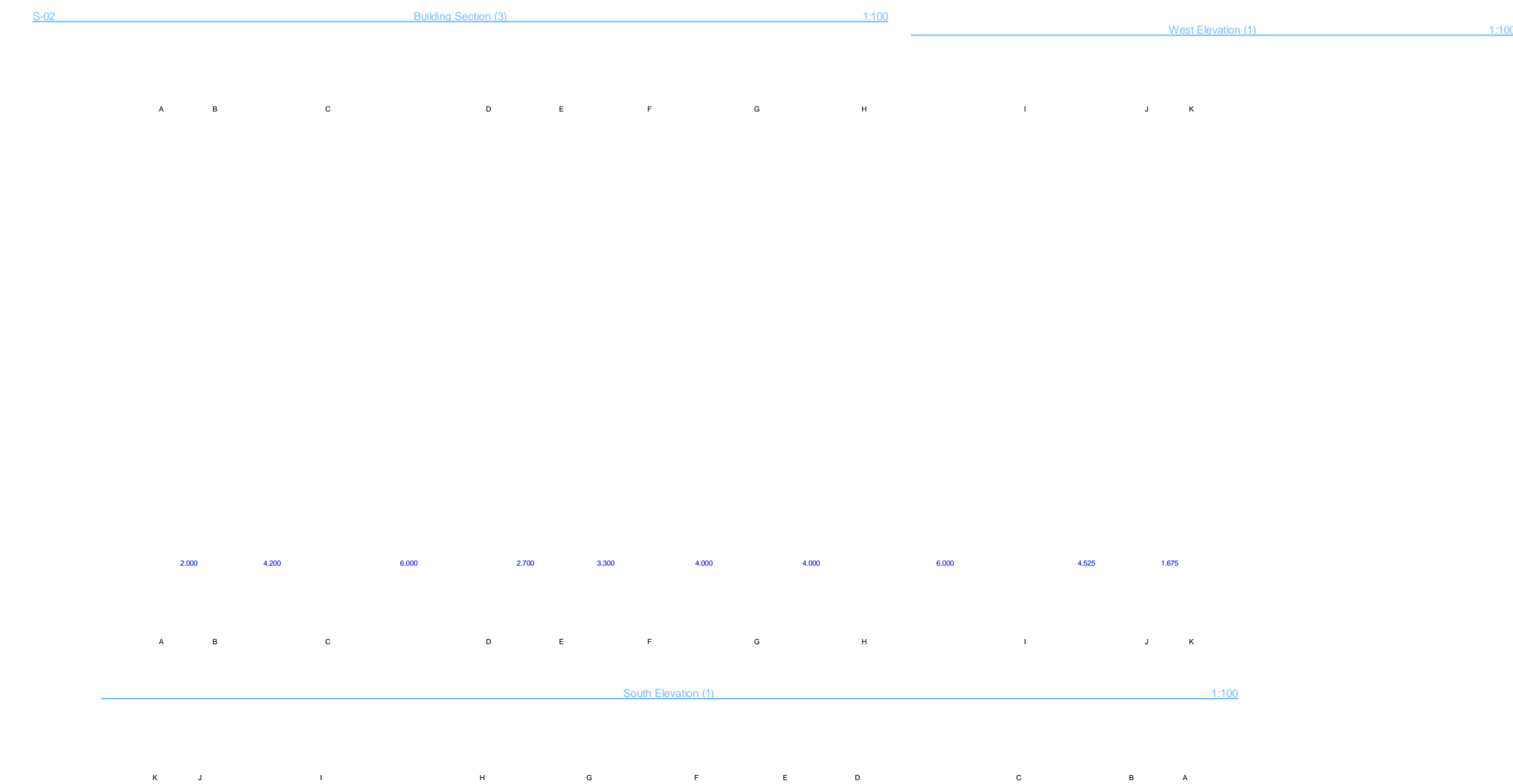
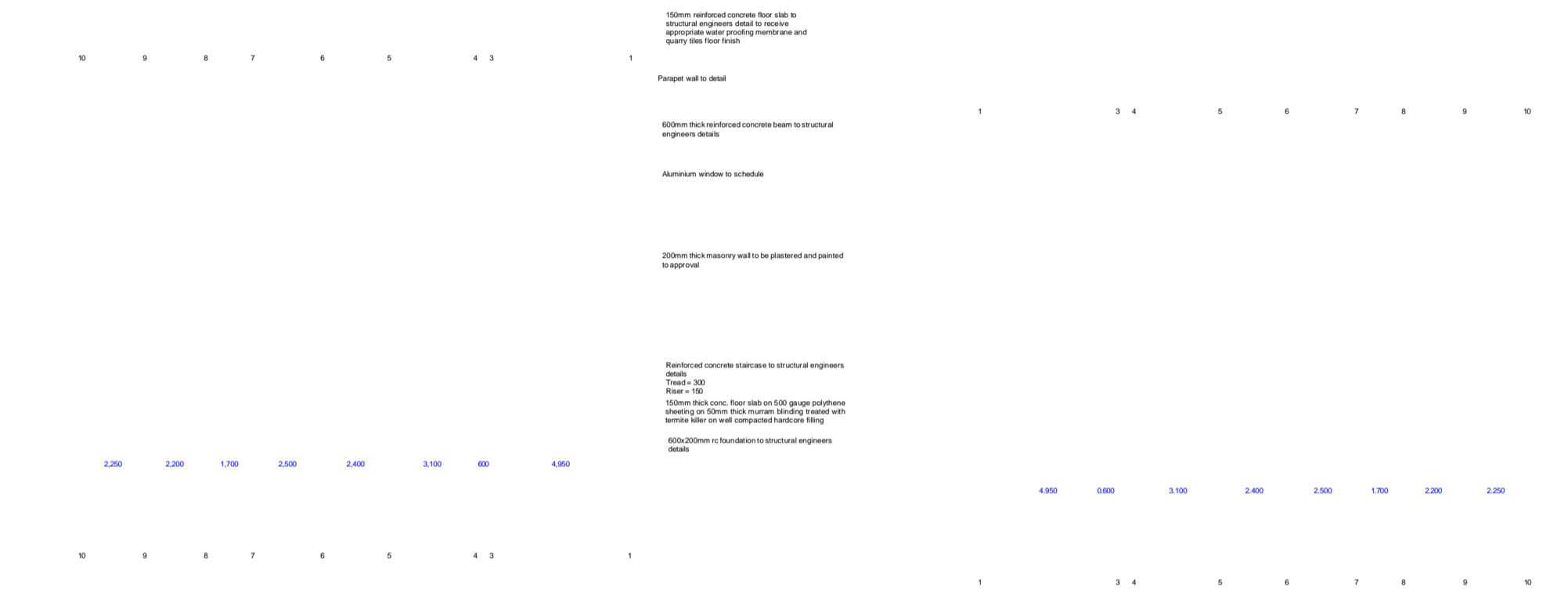

NOTES

GENERAL

1. All dimensions to be checked on site before commencement of any work.
2. Use figured dimensions only. Any discrepancies should be reported to the architect before commencement of works.
3. All dimensions are in millimeters unless otherwise specified.
4. All sanitary fittings, doors and windows to schedule
5. Permanent ventilation to be provided on all doors and windows except WC doors.
6. p.v. denotes permanent ventilation

7. All walls less than 200mm thick to be reinforced every alternate course with hoop iron.

CIVIL WORKS

1. All RC work to structural engineer's details.

STRUCTURAL WORKS

1. Refer to structural engineer's details for all RC works.
2. Foundation depth to be determined on site to architect's and structural engineer's approval.

MECHANICAL WORKS

1. All plumbing and drainage to comply with council requirements.
2. All internal fittings to be approved by architect
3. Plumbing and drainage to mechanical engineer's details
4. All soil and water pipes under paved areas, floors, drives and walls to be encased in 150mm concrete surround.

REVISION

AREA SCHEDULE

Ground floor plan	-sqm
First floor plan	-sqm
Roof slab	-sqm

TOTAL BUILT UP AREA -sqm

KCG LOGO

DEPARTMENT

PROJECT
 PROPOSED CLIMATE CHANGE
 INFORMATION CENTRE OFFICE
 DEVELOPMENT ON PLOT NO...
 SOKONI WARD
 KILIFI COUNTY
CLIENT

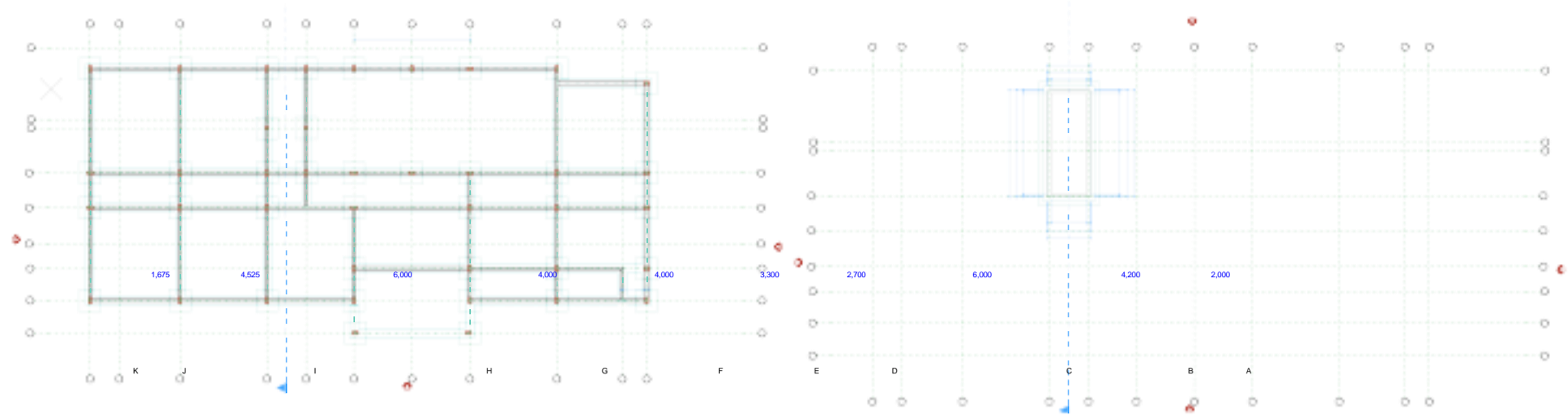

North Elevation (1) 1:100

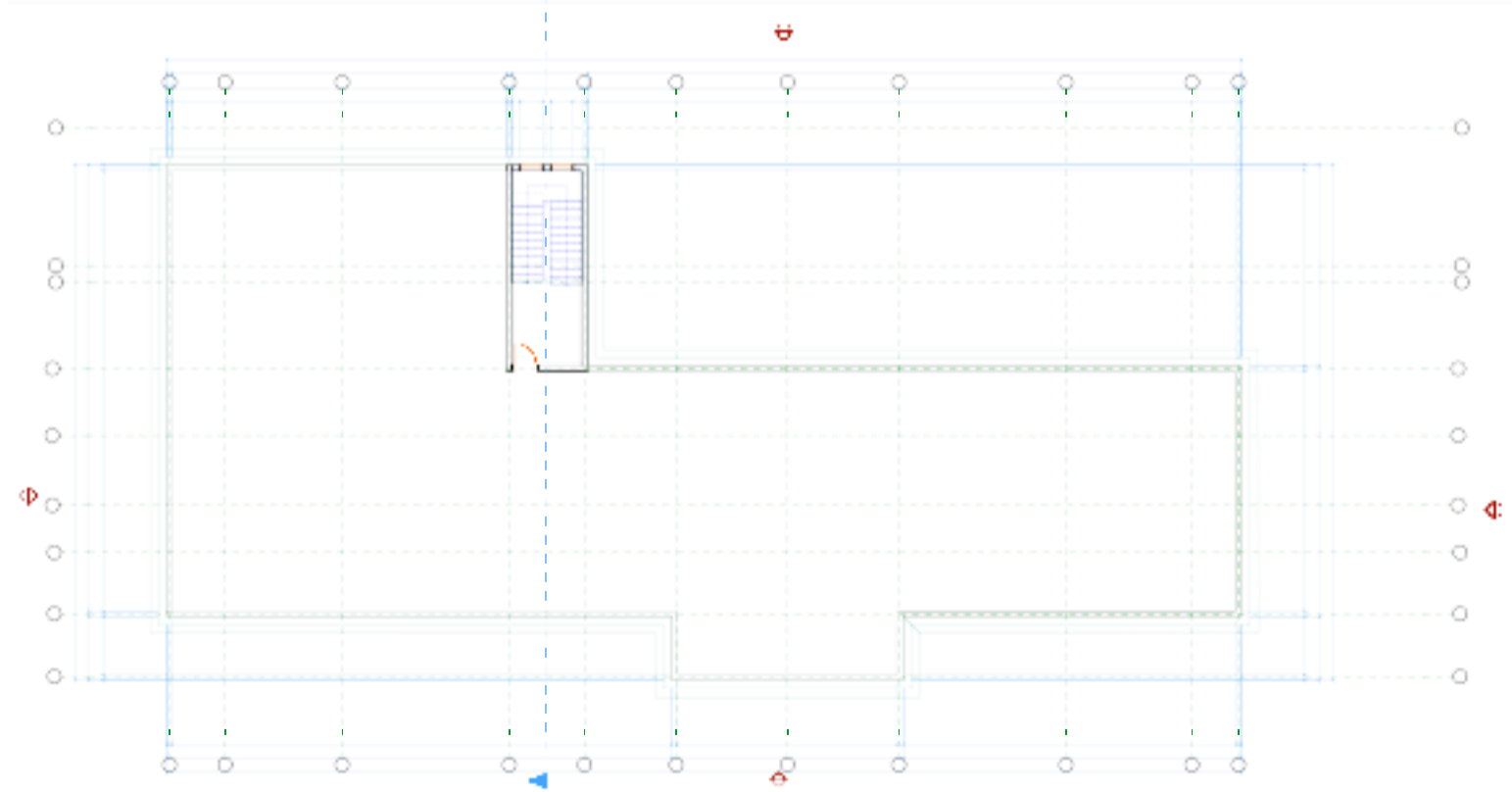
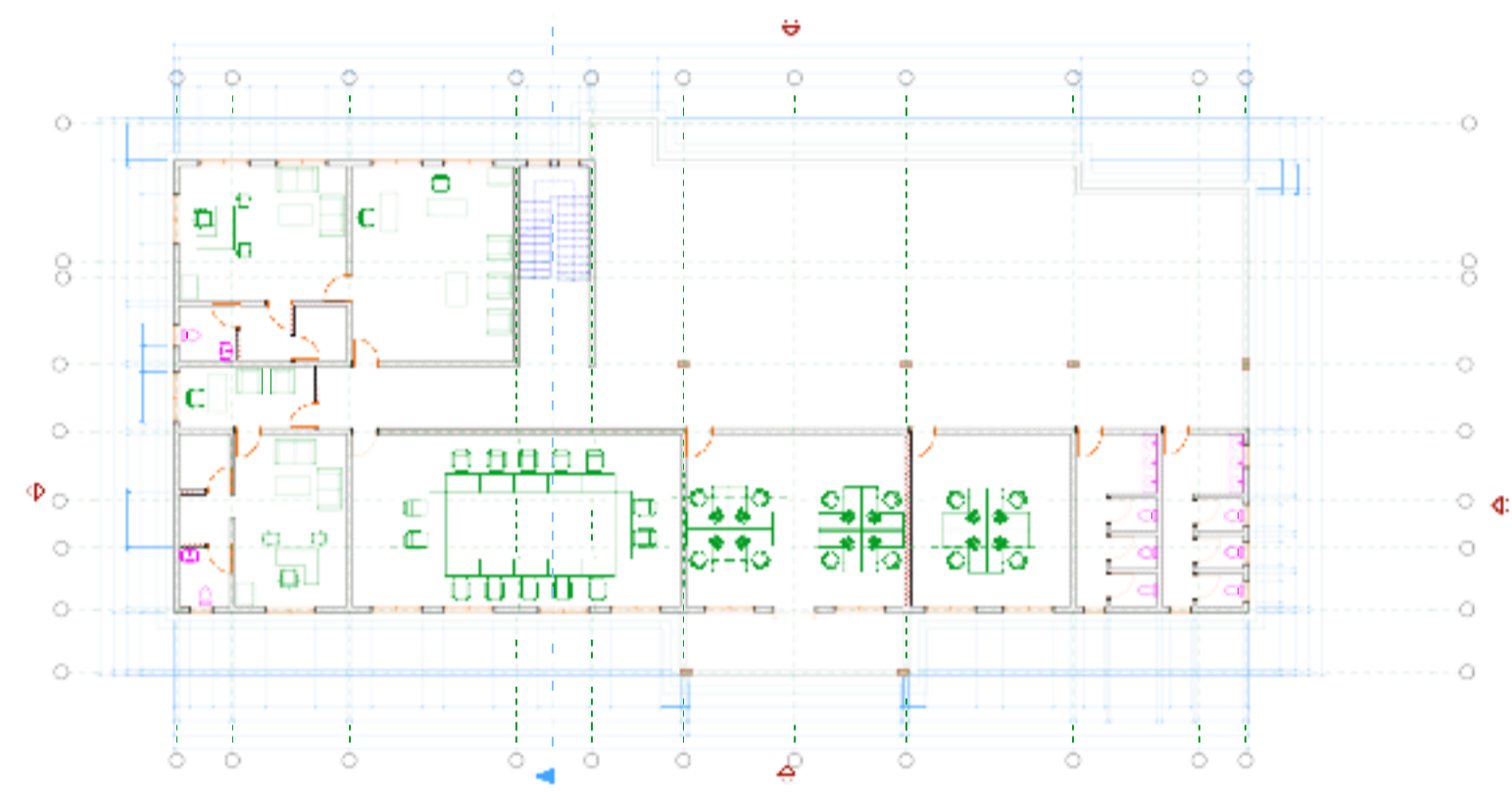
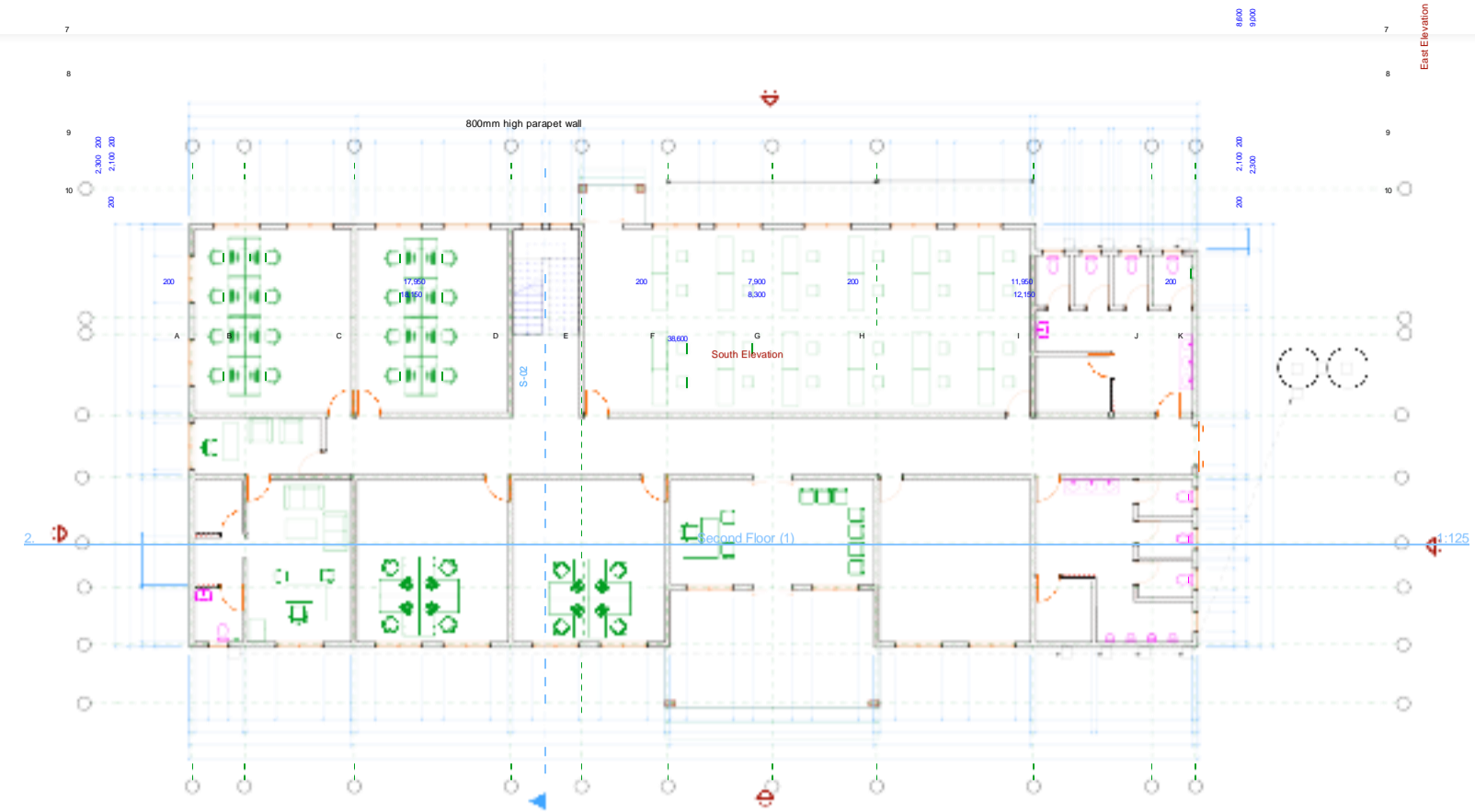
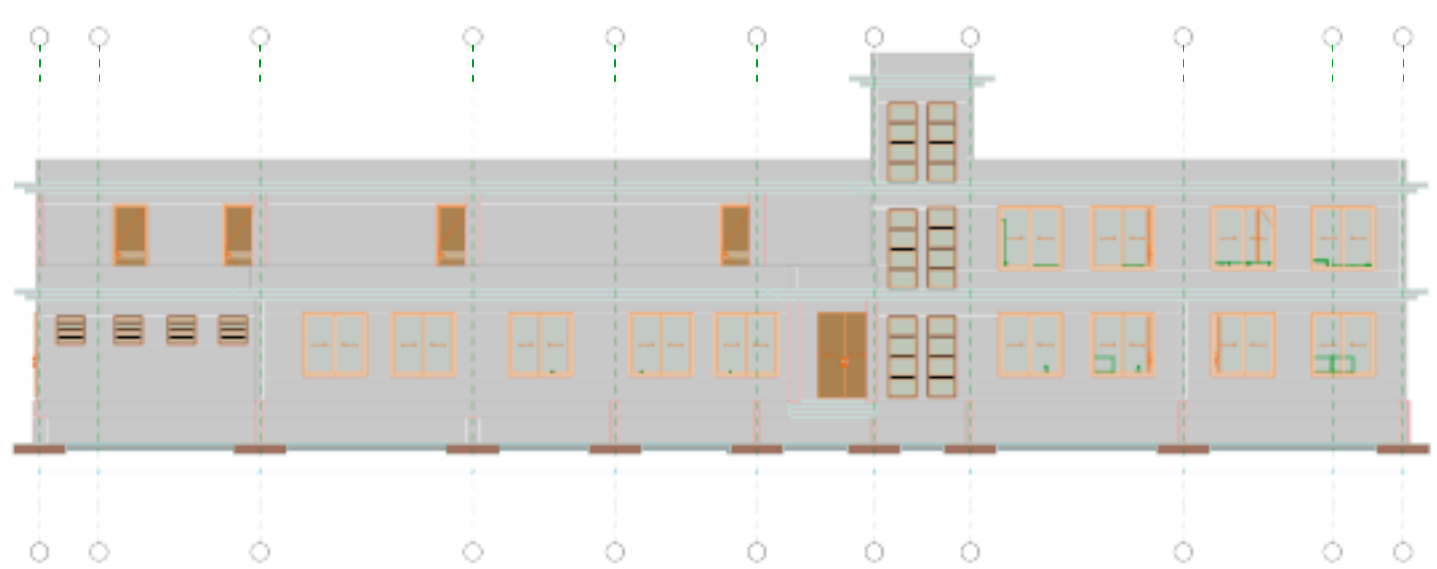
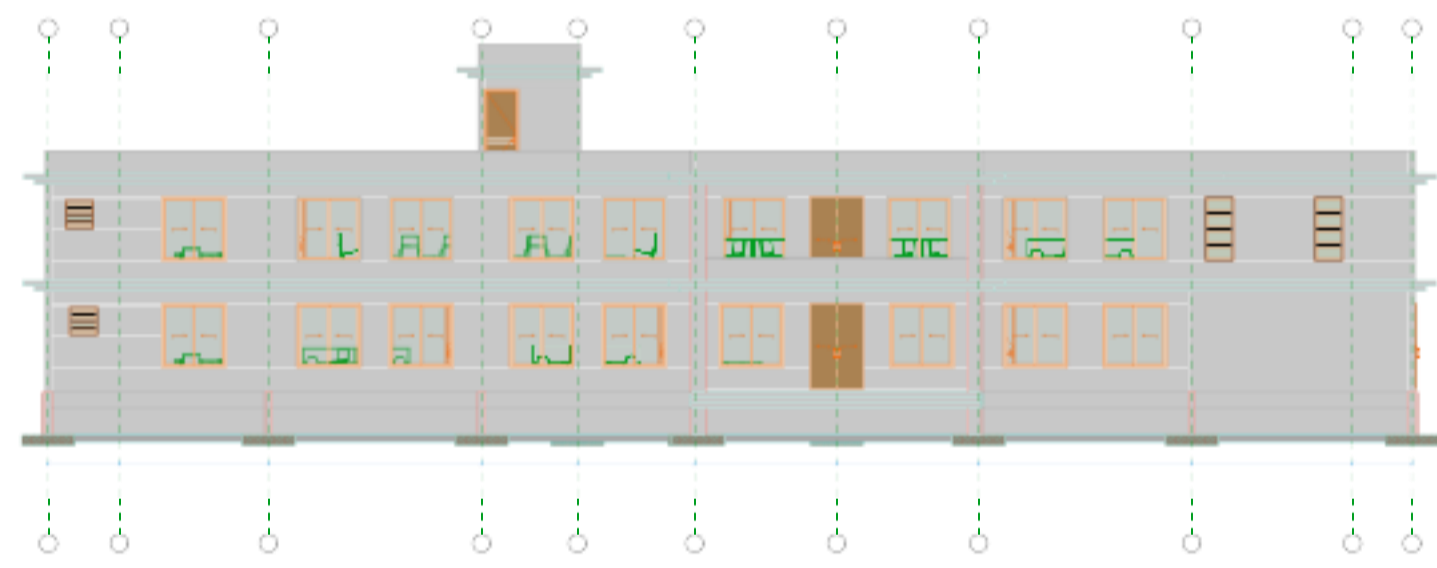
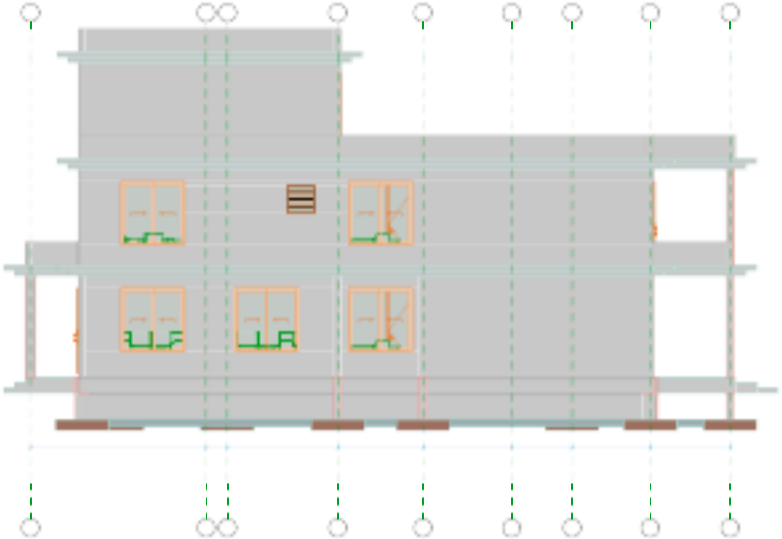
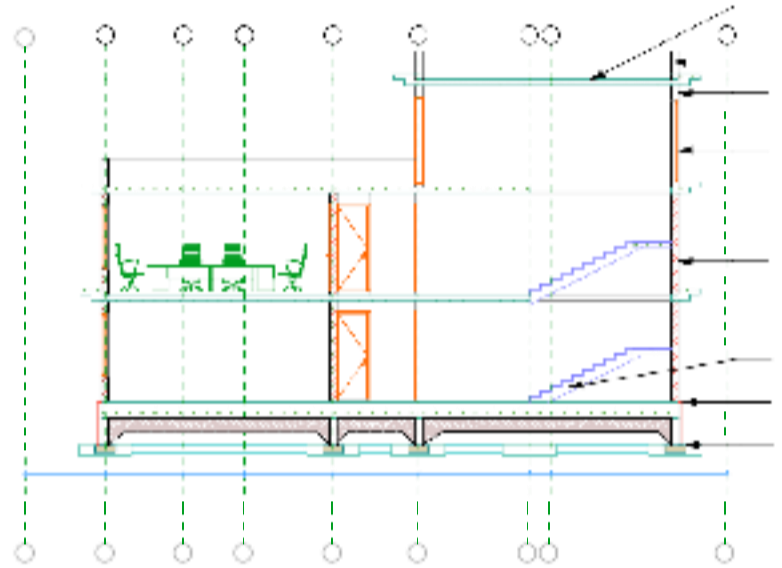

DRAWING
FLOOR PLANS

SCALE

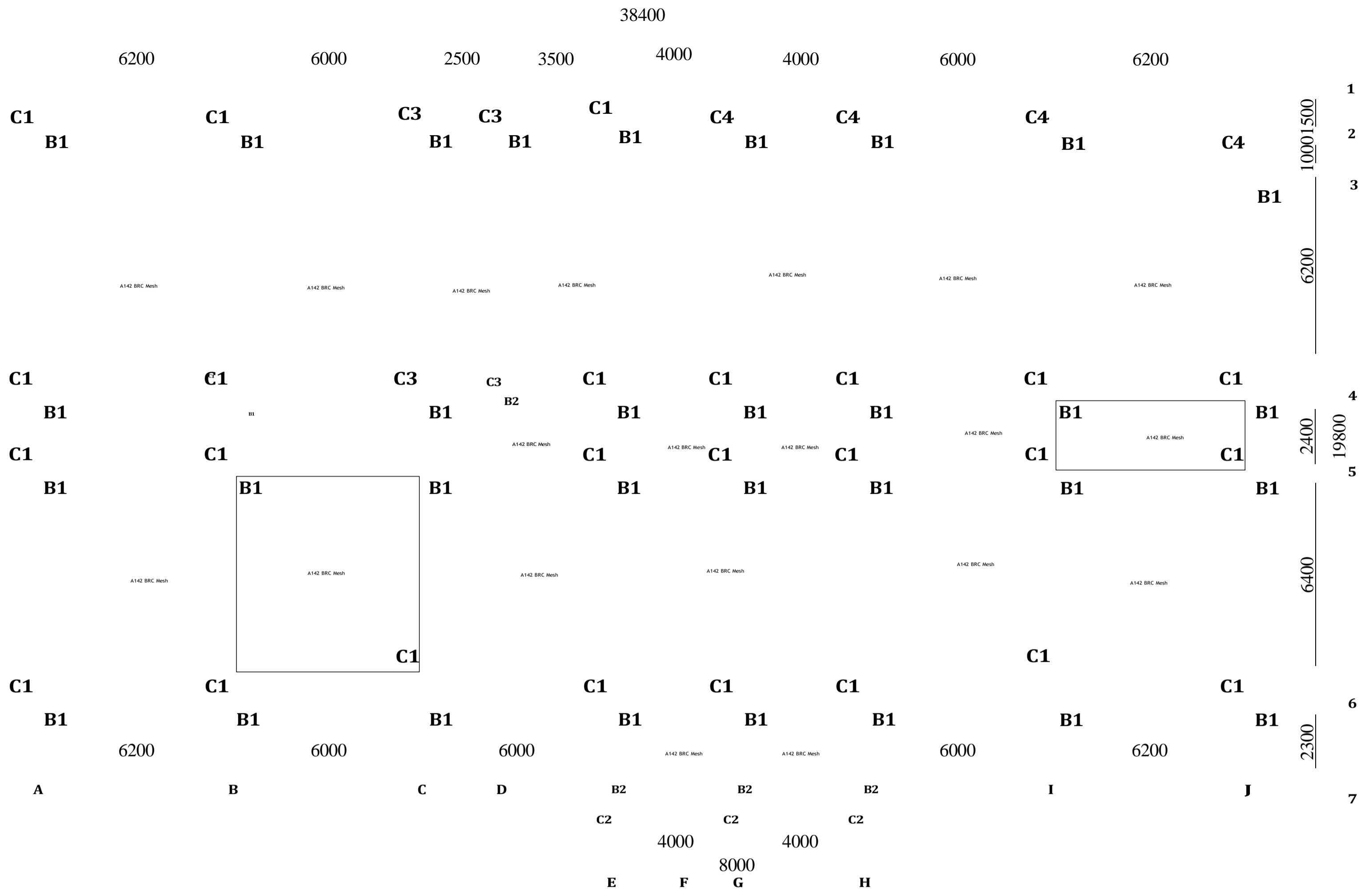

FOUNDATION LAYOUT Scale 1:50

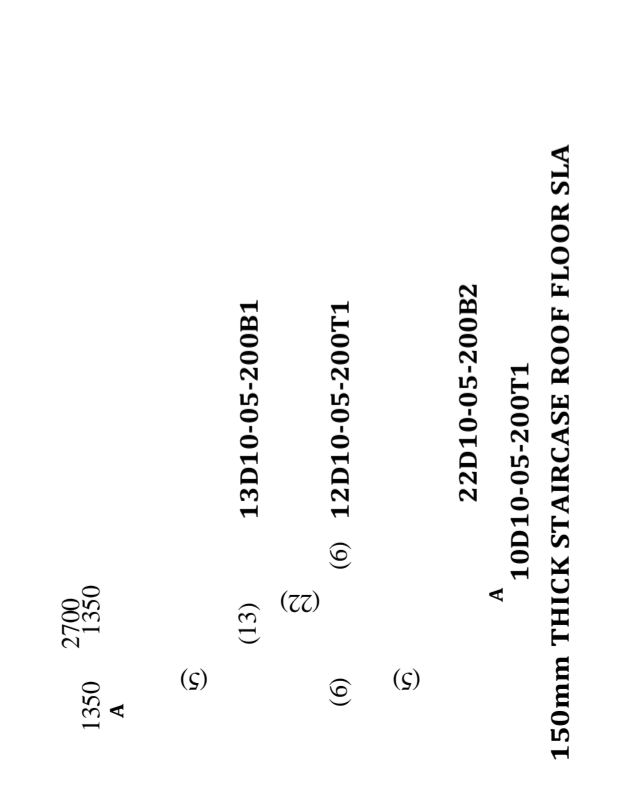
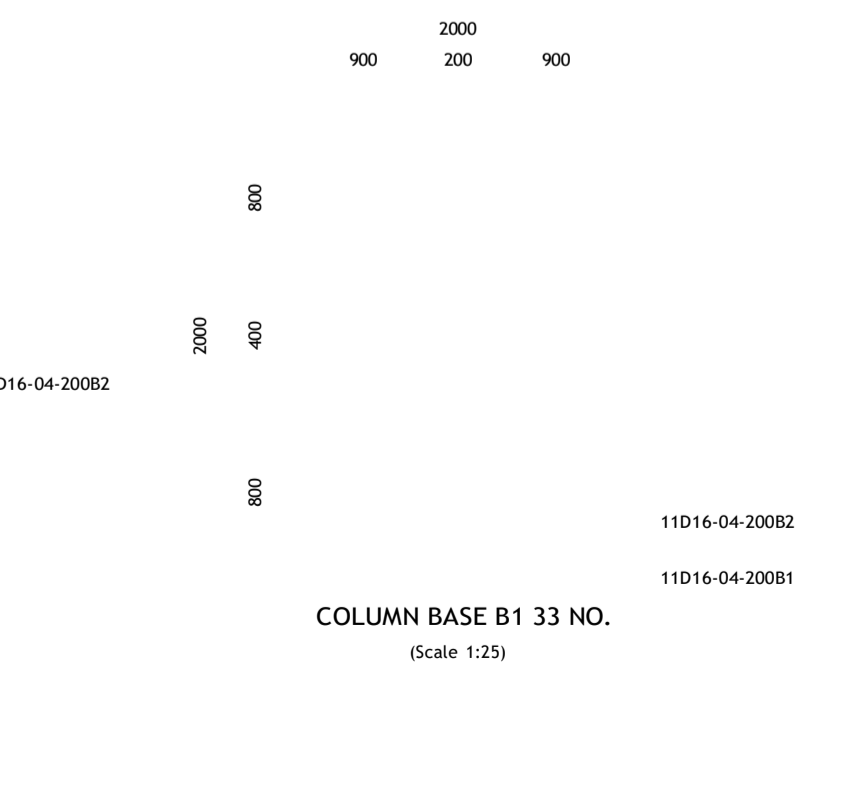
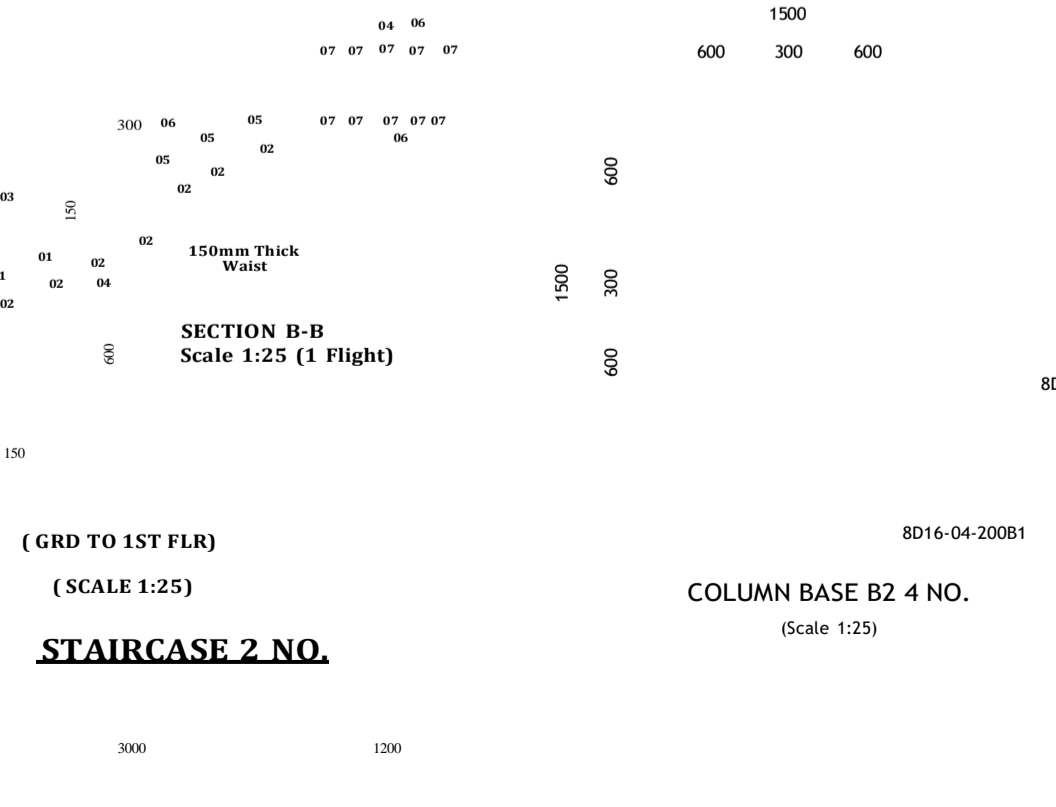
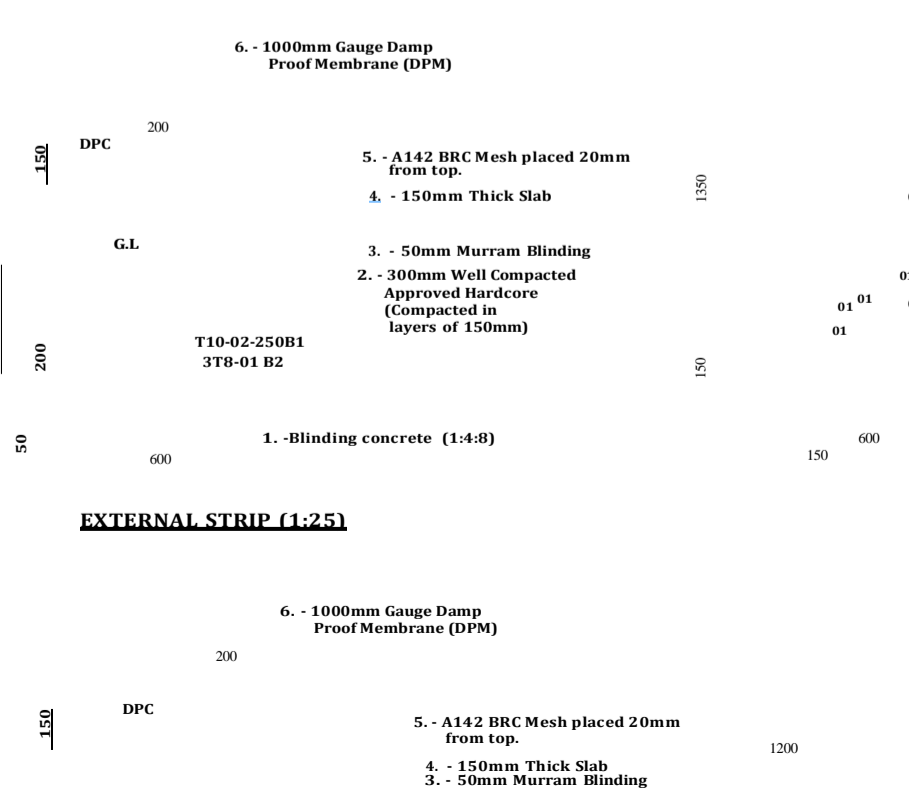

- NOTES**
- This drawing is to be read in conjunction with all other relevant Architectural/Structural drawings.
 - The Contractor to confirm all dimensions on site before commencing the works.
 - Figured dimensions only to be taken and all dimensions are in millimetres unless stated otherwise.
 - Structural Concrete to be class 20/20 (Mix: 1:2:4) Concrete cover to reinforcement including links;
 - Foundations = 50mm Columns = 40mm
 - Beams = 25mm Slabs/Stairs = 20mm
 - Reinforcement steel to be;
 - T- Ribbed high yield bars to BS 4461 and KS:ISO 6935-2
 - R-round mild bars to BS 4449.
 - All Reinforcement steel must be approved by the Structural Engineer before casting.
 - Foundation depth to be taken to firm ground. Minimum depth of foundation to be 1200mm.
 - All 200 mm thick walls to have Masonry of minimum strength of 7N/mm².
 - Foundation designed for a Ground Bearing Capacity of 150kN/M².

CLIENT	COUNTY DIVISION OF CLIMATE CHANGE - FLOCCA PROGRAMME.
	CHIEF OFFICER, ENVIRONMENT & CLIMATE CHANGE
PROJECT TITLE	PROPOSED COUNTY CLIMATE CHANGE OFFICE BLOCK
DRAWING TITLE	FOUNDATION LAYOUT, STAIRCASE AND STRIP FOOTING R.C. DETAILS.
SCALE	1:50, 1:25
	FIGURED DIMENSIONS ONLY TO BE TAKEN FROM THIS DRAWING



ENG. KINGI, GEORGE KAZUNGU, P.E
P.O. BOX 835
KILIFI.

Determine on site
(minimum 1200mm)

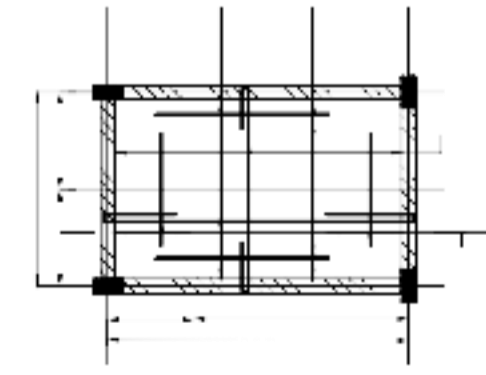
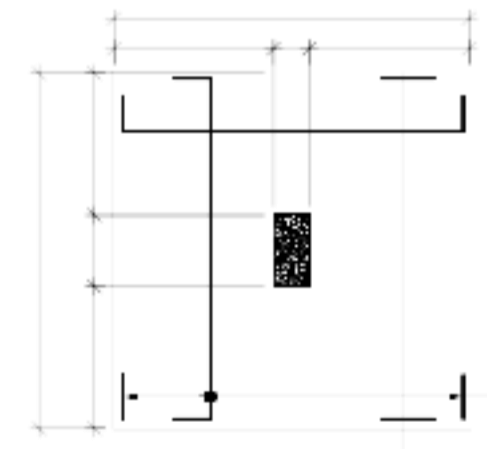
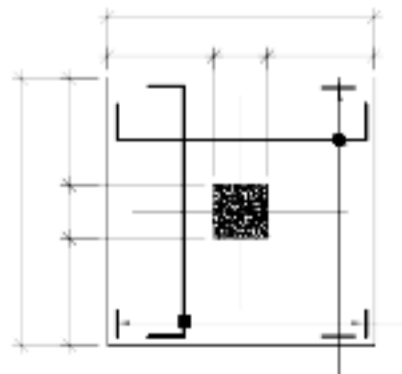
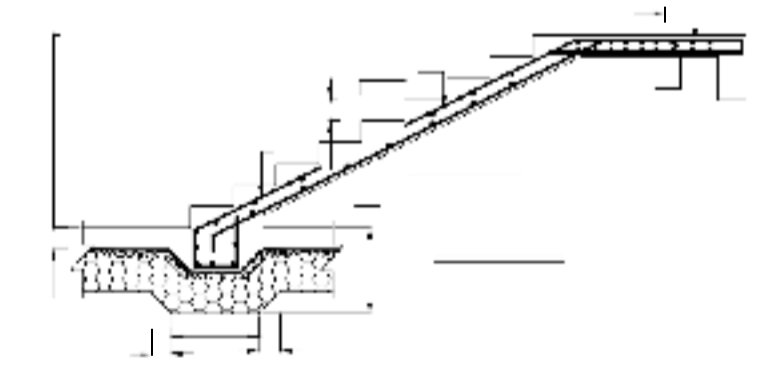
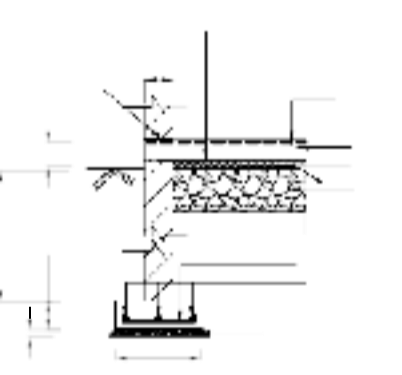

Determine on site
(minimum 1200mm)

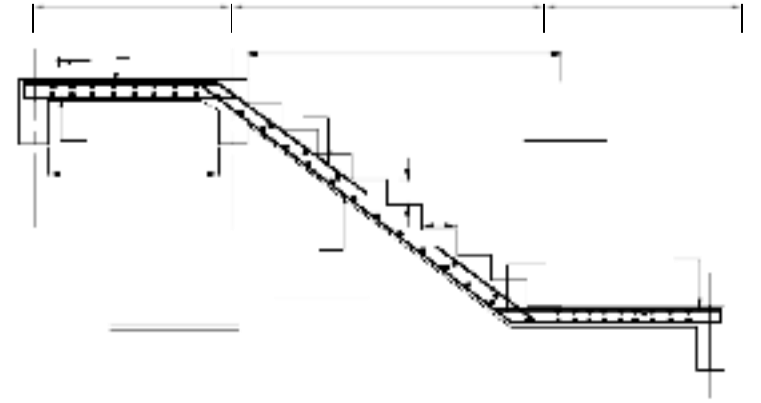

NOTES

1. This drawing is to be read in conjunction with all other relevant Architectural/Structural drawings.
2. The Contractor to confirm all dimensions on site before commencing the works.
3. Figured dimensions only to be taken and all dimensions are in millimetres unless stated otherwise.
4. Structural Concrete to be class 20/20 (Mix: 1:2:4) Concrete cover to reinforcement including links;
 - Foundations = 50mm
 - Columns = 40mm
 - Beams = 25mm
 - Slabs/Stairs = 20mm
5. Reinforcement steel to be;
 - T- Ribbed high yield bars to BS 4461 and KS:ISO 6935-2
 - R-round mild bars to BS 4449.
6. All Reinforcement steel must be approved by the Structural Engineer before casting.
7. Foundation depth to be taken to firm ground. Minimum depth of foundation to be 1200mm.
8. All 200 mm thick walls to have Masonry of minimum strength of 7N/mm².
9. Foundation designed for a Ground Bearing Capacity of 150KN/M².

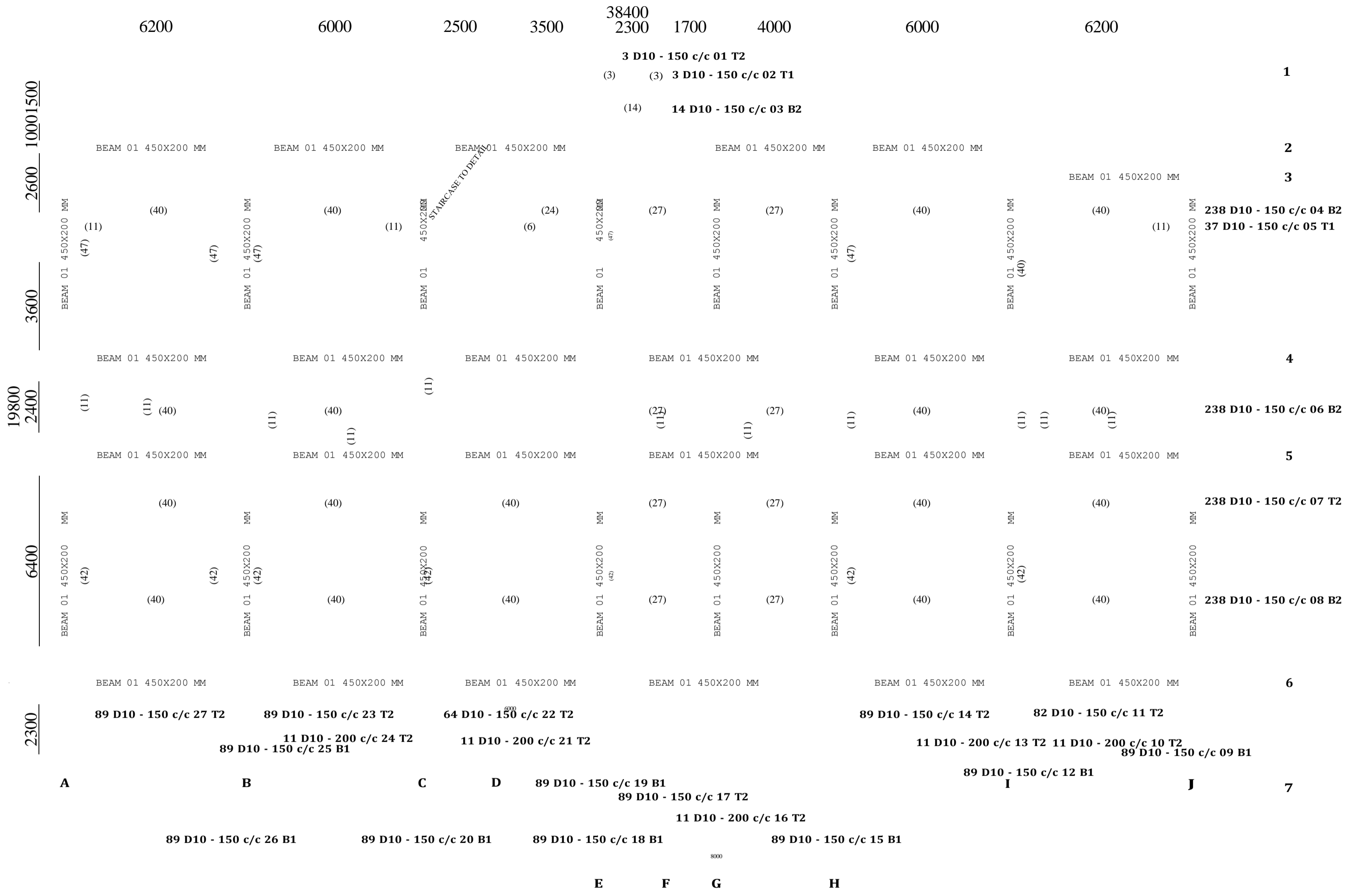

SUSPENDED SLAB REINFORCEMENT DETAILS SCALE 1:50

2Y16-08	1								
		31D8-01-200							
2D16-M-09	3D16-10	1							

CLIENT COUNTY DIVISION OF CLIMATE CHANGE - FLOCCA PROGRAMME.
CHIEF OFFICER, ENVIRONMENT & CLIMATE CHANGE

PROJECT TITLE **PROPOSED COUNTY CLIMATE CHANGE OFFICE BLOCK**

DRAWING TITLE

6200
BEAM 01 450 x 200 MM Exterior

200
SECTION 1--1

200
BEAM SECT ALL INTERIOR

SUSPENDED SLAB AND BEAM RC DETAILS

SCALE 1:50:1:25

FIGURED DIMENSIONS ONLY TO BE TAKEN FROM THIS DRAWING

Drawing No. STR-04

DESIGN/DRAWN	NAME	SIGNATURE	DATE
CHECKED	EMMANUEL KAVIHA		
	GKK		

ENG. KINGI, GEORGE KAZUNGU, P.E
P.O. BOX 835
KILIFI.

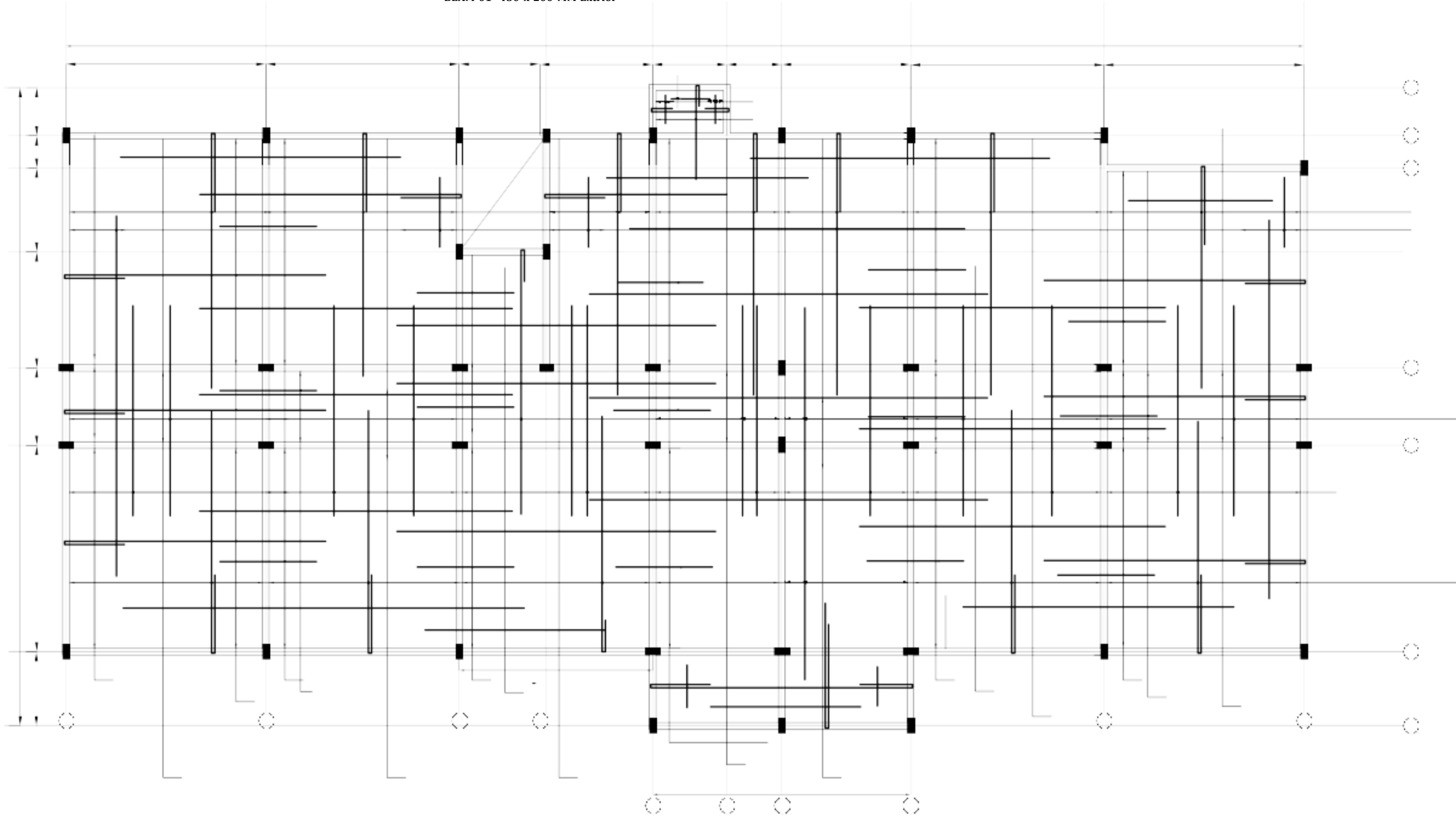

PART III - CONDITIONS OF CONTRACT AND CONTRACT FORMS

SECTION VIII - GENERAL CONDITIONS OF CONTRACT

These General Conditions of Contract (GCC), read in conjunction with the Special Conditions of Contract (SCC) and other documents listed therein, should be a complete document expressing fairly the rights and obligations of both parties.

These General Conditions of Contract have been developed on the basis of considerable international experience in the drafting and management of contracts, bearing in mind a trend in the construction industry towards simpler, more straightforward language.

The GCC can be used for both smaller admeasurement contracts and lump sum contracts.

General Conditions of Contract

A. General

1. Definitions

1.1 Bold facetype is used to identify defined terms.

- a) **The Accepted Contract Amount** means the amount accepted in the Letter of Acceptance for the execution and completion of the Works and the remedying of any defects.
- b) **The Activity Schedule** is a schedule of the activities comprising the construction, installation, testing, and commissioning of the Works in a lump sum contract. It includes a lump sum price for each activity, which is used for valuations and for assessing the effects of Variations and Compensation Events.
- c) **The Adjudicator** is the person appointed jointly by the Procuring Entity and the Contractor to resolve disputes in the first instance, as provided for in GCC 23.
- d) **Bill of Quantities** means the priced and completed Bill of Quantities forming part of the Bid.
- e) **Compensation Events** are those defined in GCC Clause 42 hereunder.
- f) **The Completion Date** is the date of completion of the Works as certified by the Project Manager, in accordance with GCC Sub-Clause 53.1.
- g) **The Contract** is the Contract between the Procuring Entity and the Contractor to execute, complete, and maintain the Works. It consists of the documents listed in GCC Sub-Clause 2.3 below.
- h) **The Contractor** is the party whose Bid to carry out the Works has been accepted by the Procuring Entity.
- i) **The Contractor's Bid** is the completed bidding document submitted by the Contractor to the Procuring Entity.
- j) **The Contract Price** is the Accepted Contract Amount stated in the Letter of Acceptance and thereafter as adjusted in accordance with the Contract.
- k) **Days** are calendar days; months are calendar months.
- l) **Day works** are varied work inputs subject to payment on a time basis for the Contractor's employees and Equipment, in addition to payments for associated Materials and Plant.
- m) **A Defect** is any part of the Works not completed in accordance with the Contract.
- n) **The Defects Liability Certificate** is the certificate issued by Project Manager upon correction of defects by the Contractor.
- o) **The Defects Liability Period** is the period **named in the SCC** pursuant to Sub-Clause 34.1 and calculated from the Completion Date.
- p) **Drawings** means the drawings of the Works, as included in the Contract, and any additional and modified drawings issued by (or on behalf of) the Procuring Entity in accordance with the Contract, include calculations and other information provided or approved by the Project Manager for the execution of the Contract.
- q) **The Procuring Entity** is the party who employs the Contractor to carry out the Works, **as specified in the SCC**, who is also the Procuring Entity.
- r) **Equipment** is the Contractor's machinery and vehicles brought temporarily to the Site to construct the Works.

- s) **“In writing” or “written”** means hand-written, type-written, printed or electronically made, and resulting in a permanent record;
- t) The Initial Contract Price is the Contract Price listed in the Procuring Entity's Letter of Acceptance.
- u) **The Intended Completion Date** is the date on which it is intended that the Contractor shall complete the Works. The Intended Completion Date is **specified in the SCC**. The Intended Completion Date may be revised only by the Project Manager by issuing an extension of time or an acceleration order.
- v) **Materials** are all supplies, including consumables, used by the Contractor for incorporation in the Works.
- w) **Plant** is any integral part of the Works that shall have a mechanical, electrical, chemical, or biological function.
- x) **The Project Manager** is the person **named in the SCC** (or any other competent person appointed by the Procuring Entity and notified to the Contractor, to act in replacement of the Project Manager) who is responsible for supervising the execution of the Works and administering the Contract.
- y) **SCC** means Special Conditions of Contract.
- z) **The Site** is the area of the works as **defined as such in the SCC**.
- aa) **Site Investigation Reports** are those that were included in the bidding document and are factual and interpretative reports about the surface and subsurface conditions at the Site.
- bb) **Specification** means the Specification of the Works included in the Contract and any modification or addition made or approved by the Project Manager.
- cc) **The Start Date** is given in the SCC. It is the latest date when the Contractor shall commence execution of the Works. It does not necessarily coincide with any of the Site Possession Dates.
- dd) **A Subcontractor** is a person or corporate body who has a Contract with the Contractor to carry out a part of the work in the Contract, which includes work on the Site.
- ee) **Temporary Works** are works designed, constructed, installed, and removed by the Contractor that are needed for construction or installation of the Works.
- ff) **A Variation** is an instruction given by the Project Manager which varies the Works.
- gg) **The Works** are what the Contract requires the Contractor to construct, install, and turn over to the Procuring Entity, **as defined in the SCC**.

2. Interpretation

- 21 In interpreting these GCC, words indicating one gender include all genders. Words indicating the singular also include the plural and words indicating the plural also include the singular. Headings have no significance. Words have their normal meaning under the language of the Contract unless specifically defined. The Project Manager shall provide instructions clarifying queries about these GCC.
- 22 If sectional completion is specified in the SCC, references in the GCC to the Works, the Completion Date, and the Intended Completion Date apply to any Section of the Works (other than references to the Completion Date and Intended Completion Date for the whole of the Works).
- 23 The documents forming the Contract shall be interpreted in the following order of priority:
 - a) Agreement,
 - b) Letter of Acceptance,
 - c) Contractor's Bid,
 - d) Special Conditions of Contract,
 - e) General Conditions of Contract, including Appendices,
 - f) Specifications,
 - g) Drawings,
 - h) Bill of Quantities⁶, and
 - i) any other document **listed in the SCC** as forming part of the Contract.

⁶*In lump sum contracts, delete “Bill of Quantities” and replace with “Activity Schedule.”*

3. Language and Law

- 31 The language of the Contract is English Language and the law governing the Contract are the Laws of Kenya.
- 32 Throughout the execution of the Contract, the Contractor shall comply with the import of goods and services prohibitions in the Procuring Entity's Country when
 - a) as a matter of law or official regulations, Kenya prohibits commercial relations with that country; or
 - b) by an act of compliance with a decision of the United Nations Security Council taken under Chapter VII of the Charter of the United Nations, Kenya prohibits any import of goods from that country or any payments to any country, person, or entity in that country.

4. Project Manager's Decisions

- 41 Except where otherwise specifically stated, the Project Manager shall decide contractual matters between the Procuring Entity and the Contractor in the role representing the Procuring Entity.

5. Delegation

- 51 Otherwise **specified in the SCC**, the Project Manager may delegate any of his duties and responsibilities to other people, except to the Adjudicator, after notifying the Contractor, and may revoke any delegation after notifying the Contractor.

6. Communications

- 61 Communications between parties that are referred to in the Conditions shall be effective only when in writing. A notice shall be effective only when it is delivered.

7. Subcontracting

- 71 The Contractor may subcontract with the approval of the Project Manager, but may not assign the Contract without the approval of the Procuring Entity in writing. Subcontracting shall not alter the Contractor's obligations.

8. Other Contractors

- 81 The Contractor shall cooperate and share the Site with other contractors, public authorities, utilities, and the Procuring Entity between the dates given in the Schedule of Other Contractors, as **referred to in the SCC**. The Contractor shall also provide facilities and services for them as described in the Schedule. The Procuring Entity may modify the Schedule of Other Contractors, and shall notify the Contractor of any such modification.

9. Personnel and Equipment

- 91 The Contractor shall employ the key personnel and use the equipment identified in its Bid, to carry out the Works or other personnel and equipment approved by the Project Manager. The Project Manager shall approve any proposed replacement of key personnel and equipment only if their relevant qualifications or characteristics are substantially equal to or better than those proposed in the Bid.
- 92 If the Project Manager asks the Contractor to remove a person who is a member of the Contractor's staff or work force, stating the reasons, the Contractor shall ensure that the person leaves the Site within seven days and has no further connection with the work in the Contract.
- 93 If the Procuring Entity, Project Manager or Contractor determines, that any employee of the Contractor be determined to have engaged in Fraud and Corruption during the execution of the Works, then that employee shall be removed in accordance with Clause 9.2 above.

10. Procuring Entity's and Contractor's Risks

- 101 The Procuring Entity carries the risks which this Contract states are Procuring Entity's risks, and the Contractor carries the risks which this Contract states are Contractor's risks.

11. Procuring Entity's Risks

- 11.1 From the Start Date until the Defects Liability Certificate has been issued, the following are Procuring Entity's risks:
- a) The risk of personal injury, death, or loss of or damage to property (excluding the Works, Plant, Materials, and Equipment), which are due to
 - i) use or occupation of the Site by the Works or for the purpose of the Works, which is the unavoidable result of the Works or
 - ii) negligence, breach of statutory duty, or interference with any legal right by the Procuring Entity or by any person employed by or contracted to him except the Contractor.
 - b) The risk of damage to the Works, Plant, Materials, and Equipment to the extent that it is due to a fault of the Procuring Entity or in the Procuring Entity's design, or due to war or radioactive contamination directly affecting the country where the Works are to be executed.
- 11.2 From the Completion Date until the Defects Liability Certificate has been issued, the risk of loss of or damage to the Works, Plant, and Materials is a Procuring Entity's risk except loss or damage due to
- aa) a Defect which existed on the Completion Date,
 - bb) an event occurring before the Completion Date, which was not itself a Procuring Entity's risk, or
 - cc) the activities of the Contractor on the Site after the Completion Date.

12. Contractor's Risks

- 12.1 From the Starting Date until the Defects Liability Certificate has been issued, the risks of personal injury, death, and loss of or damage to property (including, without limitation, the Works, Plant, Materials, and Equipment) which are not Procuring Entity's risks are Contractor's risks.

13. Insurance

- 13.1 The Contractor shall provide, in the joint names of the Procuring Entity and the Contractor, insurance cover from the Start Date to the end of the Defects Liability Period, in the amounts and deductibles **stated in the SCC** for the following events which are due to the Contractor's risks:
- a) loss of or damage to the Works, Plant, and Materials;
 - b) loss of or damage to Equipment;
 - c) loss of or damage to property (except the Works, Plant, Materials, and Equipment) in connection with the Contract; and
 - d) personal injury or death.
- 13.2 Policies and certificates for insurance shall be delivered by the Contractor to the Project Manager for the Project Manager's approval before the Start Date. All such insurance shall provide for compensation to be payable in the types and proportions of currencies required to rectify the loss or damage incurred.
- 13.3 If the Contractor does not provide any of the policies and certificates required, the Procuring Entity may effect the insurance which the Contractor should have provided and recover the premiums the Procuring Entity has paid from payments otherwise due to the Contractor or, if no payment is due, the payment of the premiums shall be a debt due.
- 13.4 Alterations to the terms of an insurance shall not be made without the approval of the Project Manager.
- 13.5 Both parties shall comply with any conditions of the insurance policies.

14. Site Data

- 14.1 The Contractor shall be deemed to have examined any Site Data **referred to in the SCC**, supplemented by any information available to the Contractor.

15. Contractor to Construct the Works

- 15.1 The Contractor shall construct and install the Works in accordance with the Specifications and Drawings.

16. The Works to Be Completed by the Intended Completion Date

- 161 The Contractor may commence execution of the Works on the Start Date and shall carry out the Works in accordance with the Program submitted by the Contractor, as updated with the approval of the Project Manager, and complete them by the Intended Completion Date.

17. Approval by the Project Manager

- 171 The Contractor shall submit Specifications and Drawings showing the proposed Temporary Works to the Project Manager, for his approval.
- 172 The Contractor shall be responsible for design of Temporary Works.
- 173 The Project Manager's approval shall not alter the Contractor's responsibility for design of the Temporary Works.
- 174 The Contractor shall obtain approval of third parties to the design of the Temporary Works, where required.
- 175 All Drawings prepared by the Contractor for the execution of the temporary or permanent Works, are subject to prior approval by the Project Manager before this use.

18. Safety

- 181 The Contractor shall be responsible for the safety of all activities on the Site.

19. Discoveries

- 191 Anything of historical or other interest or of significant value unexpectedly discovered on the Site shall be the property of the Procuring Entity. The Contractor shall notify the Project Manager of such discoveries and carry out the Project Manager's instructions for dealing with them.

20. Possession of the Site

- 201 The Procuring Entity shall give possession of all parts of the Site to the Contractor. If possession of a part is not given by the date **stated in the SCC**, the Procuring Entity shall be deemed to have delayed the start of the relevant activities, and this shall be a Compensation Event.

21. Access to the Site

- 211 The Contractor shall allow the Project Manager and any person authorized by the Project Manager access to the Site and to any place where work in connection with the Contract is being carried out or is intended to be carried out.

22. Instructions, Inspections and Audits

- 221 The Contractor shall carry out all instructions of the Project Manager which comply with the applicable laws where the Site is located.
- 222 The Contractor shall keep, and shall make all reasonable efforts to cause its Subcontractors and sub-consultants to keep, accurate and systematic accounts and records in respect of the Works in such form and details as will clearly identify relevant time changes and costs.
- 223 The Contractor shall permit and shall cause its subcontractors and sub-consultants to permit, the Procuring Entity and/or persons appointed by the Public Procurement Regulatory Authority to inspect the Site and/or the accounts and records relating to the procurement process, selection and/or contract execution, and to have such accounts and records audited by auditors appointed by the Public Procurement Regulatory Authority. The Contractor's and its Subcontractors' and sub-consultants' attention is drawn to Sub-Clause 25.1 (Fraud and Corruption) which provides, inter alia, that acts intended to materially impede the exercise of the Public Procurement Regulatory Authority's inspection and audit rights constitute a prohibited practice subject to contract termination (as well as to a determination of ineligibility pursuant to the Public Procurement Regulatory Authority's prevailing sanctions procedures).

23. Appointment of the Adjudicator

- 23.1 The Adjudicator shall be appointed jointly by the Procuring Entity and the Contractor, at the time of the Procuring Entity's issuance of the Letter of Acceptance. If, in the Letter of Acceptance, the Procuring Entity does not agree on the appointment of the Adjudicator, the Procuring Entity will request the Appointing Authority designated in the SCC, to appoint the Adjudicator within 14 days of receipt of such request.
- 23.2 Should the Adjudicator resign or die, or should the Procuring Entity and the Contractor agree that the Adjudicator is not functioning in accordance with the provisions of the Contract, a new Adjudicator shall be jointly appointed by the Procuring Entity and the Contractor. In case of disagreement between the Procuring Entity and the Contractor, within 30 days, the Adjudicator shall be designated by the Appointing Authority designated in the SCC at the request of either party, within 14 days of receipt of such request.

24. Settlement of Claims and Disputes

24.1 Contractor's Claims

- 24.1.1 If the Contractor considers itself to be entitled to any extension of the Time for Completion and/or any additional payment, under any Clause of these Conditions or otherwise in connection with the Contract, the Contractor shall give Notice to the Project Manager, describing the event or circumstance giving rise to the claim. The notice shall be given as soon as practicable, and not later than 30 days after the Contractor became aware, or should have become aware, of the event or circumstance.
- 24.1.2 If the Contractor fails to give notice of a claim within such period of 30 days, the Time for Completion shall not be extended, the Contractor shall not be entitled to additional payment, and the Procuring Entity shall be discharged from all liability in connection with the claim. Otherwise, the following provisions of this Sub- Clause shall apply.
- 24.1.3 The Contractor shall also submit any other notices which are required by the Contract, and supporting particulars for the claim, all as relevant to such event or circumstance.
- 24.1.4 The Contractor shall keep such contemporary records as may be necessary to substantiate any claim, either on the Site or at another location acceptable to the Project Manager. Without admitting the Procuring Entity's liability, the Project Manager may, after receiving any notice under this Sub-Clause, monitor the record- keeping and/or instruct the Contractor to keep further contemporary records. The Contractor shall permit the Project Manager to inspect all these records, and shall (if instructed) submit copies to the Project Manager.
- 24.1.5 Within 42 days after the Contractor became aware (or should have become aware) of the event or circumstance giving rise to the claim, or within such other period as may be proposed by the Contractor and approved by the Project Manager, the Contractor shall send to the Project Manager a fully detailed claim which includes full supporting particulars of the basis of the claim and of the extension of time and/or additional payment claimed. If the event or circumstance giving rise to the claim has a continuing effect:
- a) this fully detailed claim shall be considered as interim;
 - b) the Contractor shall send further interim claims at monthly intervals, giving the accumulated delay and/or amount claimed, and such further particulars as the Project Manager may reasonably require; and
 - c) the Contractor shall send a final claim within 30 days after the end of the effects resulting from the event or circumstance, or within such other period as may be proposed by the Contractor and approved by the Project Manager.
- 24.1.6 Within 42 days after receiving a Notice of a claim or any further particulars supporting a previous claim, or within such other period as may be proposed by the Project Manager and approved by the Contractor, the Project Manager shall respond with approval, or with disapproval and detailed comments. He may also request any necessary further particulars, but shall nevertheless give his response on the principles of the claim within the above defined time period.
- 24.1.7 Within the above defined period of 42 days, the Project Manager shall proceed in accordance with Sub-Clause
- 24.1.8 [Determinations] to agree or determine (i) the extension (if any) of the Time for Completion (before or after its expiry) in accordance with Sub-Clause 8.4 [Extension of Time for Completion], and/or (ii) the

additional payment (if any) to which the Contractor is entitled under the Contract.

24.1.9 Each Payment Certificate shall include such additional payment for any claim as has been reasonably substantiated as due under the relevant provision of the Contract. Unless and until the particulars supplied are sufficient to substantiate the whole of the claim, the Contractor shall only be entitled to payment for such part of the claim as he has been able to substantiate.

24.1.10 If the Project Manager does not respond within the timeframe defined in this Clause, either Party may consider that the claim is rejected by the Project Manager and any of the Parties may refer to Arbitration in accordance with Sub-Clause 24.4 [Arbitration].

24.1.11 The requirements of this Sub-Clause are in addition to those of any other Sub-Clause which may apply to a claim. If the Contractor fails to comply with this or another Sub-Clause in relation to any claim, any extension of time and/or additional payment shall take account of the extent (if any) to which the failure has prevented or prejudiced proper investigation of the claim, unless the claim is excluded under the second paragraph of this Sub-Clause 24.3.

242 Amicable Settlement

24.2.1 Where a notice of a claim has been given, both Parties shall attempt to settle the dispute amicably before the commencement of arbitration. However, unless both Parties agree otherwise, the Party giving a notice of a claim in accordance with Sub-Clause 24.1 above should move to commence arbitration after the fifty-sixth day from the day on which a notice of a claim was given, even if no attempt at an amicable settlement has been made.

243 Matters that may be referred to arbitration

24.3.1 Notwithstanding anything stated herein the following matters may be referred to arbitration before the practical completion of the Works or abandonment of the Works or termination of the Contract by either party:

- a) The appointment of a replacement Project Manager upon the said person ceasing to act.
- b) Whether or not the issue of an instruction by the Project Manager is empowered by these Conditions.
- c) Whether or not a certificate has been improperly withheld or is not in accordance with these Conditions.
- e) Any dispute arising in respect of war risks or war damage.
- f) All other matters shall only be referred to arbitration after the completion or alleged completion of the Works or termination or alleged termination of the Contract, unless the Procuring Entity and the Contractor agree otherwise in writing.

244 Arbitration

24.4.1 Any claim or dispute between the Parties arising out of or in connection with the Contract not settled amicably in accordance with Sub-Clause 24.3 shall be finally settled by arbitration.

24.4.2 No arbitration proceedings shall be commenced on any claim or dispute where notice of a claim or dispute has not been given by the applying party within ninety days of the occurrence or discovery of the matter or issue giving rise to the dispute.

24.4.3 Notwithstanding the issue of a notice as stated above, the arbitration of such a claim or dispute shall not commence unless an attempt has in the first instance been made by the parties to settle such claim or dispute amicably with or without the assistance of third parties. Proof of such attempt shall be required.

24.4.4 The Arbitrator shall, without prejudice to the generality of his powers, have powers to direct such measurements, computations, tests or valuations as may in his opinion be desirable in order to determine the rights of the parties and assess and award any sums which ought to have been the subject of or included in any certificate.

24.4.5 The Arbitrator shall, without prejudice to the generality of his powers, have powers to open up, review and revise any certificate, opinion, decision, requirement or notice and to determine all matters in dispute which shall be submitted to him in the same manner as if no such certificate, opinion, decision requirement or notice had been given.

24.4.6 The arbitrators shall have full power to open up, review and revise any certificate, determination, instruction, opinion or valuation of the Project Manager, relevant to the dispute. Nothing shall disqualify representatives of the Parties and the Project Manager from being called as a witness and giving evidence before the arbitrators on any matter whatsoever relevant to the dispute.

24.4.7 Neither Party shall be limited in the proceedings before the arbitrators to the evidence, or to the reasons for dissatisfaction given in its Notice of Dissatisfaction.

24.4.8 Arbitration may be commenced prior to or after completion of the Works. The obligations of the Parties, and the Project Manager shall not be altered by reason of any arbitration being conducted during the progress of the Works.

24.4.9 The terms of the remuneration of each or all the members of Arbitration shall be mutually agreed upon by the

Parties when agreeing the terms of appointment. Each Party shall be responsible for paying one-half of this remuneration.

245 Arbitration with National Contractors

24.5.1 If the Contract is with national contractors, arbitration proceedings will be conducted in accordance with the Arbitration Laws of Kenya. In case of any claim or dispute, such claim or dispute shall be notified in writing by either party to the other with a request to submit it to arbitration and to concur in the appointment of an Arbitrator within thirty days of the notice. The dispute shall be referred to the arbitration and final decision of a person to be agreed between the parties. Failing agreement to concur in the appointment of an Arbitrator, the Arbitrator shall be appointed, on the request of the applying party, by the Chairman or Vice Chairman of any of the following professional institutions;

- i) Architectural Association of Kenya
- ii) Institute of Quantity Surveyors of Kenya
- iii) Association of Consulting Engineers of Kenya
- iv) Chartered Institute of Arbitrators (Kenya Branch)
- v) Institution of Engineers of Kenya

24.5.2 The institution written to first by the aggrieved party shall take precedence over all other institutions.

246 Alternative Arbitration Proceedings

24.6.1 Alternatively, the Parties may refer the matter to the Nairobi Centre for International Arbitration (NCIA) which offers a neutral venue for the conduct of national and international arbitration with commitment to providing institutional support to the arbitral process.

247 Failure to Comply with Arbitrator's Decision

24.7.1 The award of such Arbitrator shall be final and binding upon the parties.

24.7.2 In the event that a Party fails to comply with a final and binding Arbitrator's decision, then the other Party may, without prejudice to any other rights it may have, refer the matter to a competent court of law.

248 Contract operations to continue

24.8.1 Notwithstanding any reference to arbitration herein,

- a) the parties shall continue to perform their respective obligations under the Contract unless they otherwise agree; and
- b) the Procuring Entity shall pay the Contractor any monies due to the Contractor.

25. Fraud and Corruption

25.1 The Government requires compliance with the country's Anti-Corruption laws and its prevailing sanctions policies and procedures as set forth in the Constitution of Kenya and its Statutes.

25.2 The Procuring Entity requires the Contractor to disclose any commissions or fees that may have been paid or are to be paid to agents or any other party with respect to the bidding process or execution of the Contract. The information disclosed must include at least the name and address of the agent or other party, the amount and currency, and the purpose of the commission, gratuity or fee.

B. Time Control

26. Program

26.1 Within the time stated in the SCC, after the date of the Letter of Acceptance, the Contractor shall submit to the Project Manager for approval a Program showing the general methods, arrangements, order, and timing for all the activities in the Works. In the case of a lump sum contract, the activities in the Program shall be consistent with those in the Activity Schedule.

26.2 An update of the Program shall be a program showing the actual progress achieved on each activity and the effect of the progress achieved on the timing of the remaining work, including any changes to the sequence of the activities.

26.3 The Contractor shall submit to the Project Manager for approval an updated Program at intervals no longer than the period stated in the SCC. If the Contractor does not submit an updated Program within this period, the Project Manager may withhold the amount stated in the SCC from the next payment certificate and

continue to withhold this amount until the next payment after the date on which the overdue Program has been submitted. In the case of a lump sum contract, the Contractor shall provide an updated Activity Schedule within 14 days of being instructed to by the Project Manager.

- 264 The Project Manager's approval of the Program shall not alter the Contractor's obligations. The Contractor may revise the Program and submit it to the Project Manager again at any time. A revised Program shall show the effect of Variations and Compensation Events.

27. Extension of the Intended Completion Date

- 271 The Project Manager shall extend the Intended Completion Date if a Compensation Event occurs or a Variation is issued which makes it impossible for Completion to be achieved by the Intended Completion Date without the Contractor taking steps to accelerate the remaining work, which would cause the Contractor to incur additional cost.
- 272 The Project Manager shall decide whether and by how much to extend the Intended Completion Date within 21 days of the Contractor asking the Project Manager for a decision upon the effect of a Compensation Event or Variation and submitting full supporting information. If the Contractor has failed to give early warning of a delay or has failed to cooperate in dealing with a delay, the delay by this failure shall not be considered in assessing the new Intended Completion Date.

28. Acceleration

- 281 When the Procuring Entity wants the Contractor to finish before the Intended Completion Date, the Project Manager shall obtain priced proposals for achieving the necessary acceleration from the Contractor. If the Procuring Entity accepts these proposals, the Intended Completion Date shall be adjusted accordingly and confirmed by both the Procuring Entity and the Contractor.
- 282 If the Contractor's priced proposals for an acceleration are accepted by the Procuring Entity, they are incorporated in the Contract Price and treated as a Variation.

29. Delays Ordered by the Project Manager

- 291 The Project Manager may instruct the Contractor to delay the start or progress of any activity within the Works.

30. Management Meetings

- 301 Either the Project Manager or the Contractor may require the other to attend a management meeting. The business of a management meeting shall be to review the plans for remaining work and to deal with matters raised in accordance with the early warning procedure.
- 302 The Project Manager shall record the business of management meetings and provide copies of the record to those attending the meeting and to the Procuring Entity. The responsibility of the parties for actions to be taken shall be decided by the Project Manager either at the management meeting or after the management meeting and stated in writing to all who attended the meeting.

31. Early Warning

- 311 The Contractor shall warn the Project Manager at the earliest opportunity of specific likely future events or circumstances that may adversely affect the quality of the work, increase the Contract Price, or delay the execution of the Works. The Project Manager may require the Contractor to provide an estimate of the expected effect of the future event or circumstance on the Contract Price and Completion Date. The estimate shall be provided by the Contractor as soon as reasonably possible.
- 312 The Contractor shall cooperate with the Project Manager in making and considering proposals for how the effect of such an event or circumstance can be avoided or reduced by anyone involved in the work and in carrying out any resulting instruction of the Project Manager.

C. Quality Control

32. Identifying Defects

- 321 The Project Manager shall check the Contractor's work and notify the Contractor of any Defects that are found. Such checking shall not affect the Contractor's responsibilities. The Project Manager may instruct the Contractor to search for a Defect and to uncover and test any work that the Project Manager considers may have a Defect.

33. Tests

- 331 If the Project Manager instructs the Contractor to carry out a test not specified in the Specification to check whether any work has a Defect and the test shows that it does, the Contractor shall pay for the test and any samples. If there is no Defect, the test shall be a Compensation Event.

34. Correction of Defects

- 341 The Project Manager shall give notice to the Contractor of any Defects before the end of the Defects Liability Period, which begins at Completion, and is defined in the SCC. The Defects Liability Period shall be extended for as long as Defects remain to be corrected.
- 342 Every time notice of a Defect is given, the Contractor shall correct the notified Defect within the length of time specified by the Project Manager's notice.

35. Uncorrected Defects

- 351 If the Contractor has not corrected a Defect within the time specified in the Project Manager's notice, the Project Manager shall assess the cost of having the Defect corrected, and the Contractor shall pay this amount.

D. Cost Control

36. Contract Price⁷

- 361 The Bill of Quantities shall contain priced items for the Works to be performed by the Contractor. The Bill of Quantities is used to calculate the Contract Price. The Contractor will be paid for the quantity of the work accomplished at the rate in the Bill of Quantities for each item.

37. Changes in the Contract Price⁸

- 371 If the final quantity of the work done differs from the quantity in the Bill of Quantities for the particular item by more than 25 percent, provided the change exceeds 1 percent of the Initial Contract Price, the Project Manager shall adjust the rate to allow for the change. The Project Manager shall not adjust rates from changes in quantities if thereby the Initial Contract Price is exceeded by more than 15 percent, except with the prior approval of the Procuring Entity.
- 372 If requested by the Project Manager, the Contractor shall provide the Project Manager with a detailed cost breakdown of any rate in the Bill of Quantities.

38. Variations

- 381 All Variations shall be included in updated Programs⁹ produced by the Contractor.
- 382 The Contractor shall provide the Project Manager with a quotation for carrying out the Variation when requested to do so by the Project Manager. The Project Manager shall assess the quotation, which shall be given within seven (7) days of the request or within any longer period stated by the Project Manager and before the Variation is ordered.
- 383 If the Contractor's quotation is unreasonable, the Project Manager may order the Variation and make a change to the Contract Price, which shall be based on the Project Manager's own forecast of the effects of the Variation on the Contractor's costs.
- 384 If the Project Manager decides that the urgency of varying the work would prevent a quotation being given and considered without delaying the work, no quotation shall be given and the Variation shall be treated as a Compensation Event.

⁷In lump sum contracts, replace GCC Sub-Clauses 36.1 as follows:

36.1 The Contractor shall provide updated Activity Schedules within 14 days of being instructed to by the Project Manager. The Activity Schedule shall contain the priced activities for the Works to be performed by the Contractor. The Activity Schedule is used to monitor and control the performance of activities on which basis the Contractor will be paid. If payment for materials on site shall be made separately, the Contractor shall show delivery of Materials to the Site separately on the Activity Schedule.

⁸In lump sum contracts, replace entire GCC Clause 37 with new GCC Sub-Clause 37.1, as follows:

The Activity Schedule shall be amended by the Contractor to accommodate changes of Program or method of working made at the Contractor's own discretion. Prices in the Activity Schedules shall not be altered when the Contractor makes such changes to the Activity Schedule.

⁹In lump sum contracts, add "and Activity Schedules" after "Programs." ¹⁰In lump sum contracts, delete this paragraph.

The Contractor shall not be entitled to additional payment for costs that could have been avoided by giving

early warning

- 385 If the work in the Variation corresponds to an item description in the Bill of Quantities and if, in the opinion of the Project Manager, the quantity of work above the limit stated in Sub-Clause 39.1 or the timing of its execution do not cause the cost per unit of quantity to change, the rate in the Bill of Quantities shall be used to calculate the value of the Variation. If the cost per unit of quantity changes, or if the nature or timing of the work in the Variation does not correspond with items in the Bill of Quantities, the quotation by the Contractor shall be in the form of new rates for the relevant items of work
- 386 Value Engineering: The Contractor may prepare, at its own cost, a value engineering proposal at any time during the performance of the contract. The value engineering proposal shall, at a minimum, include the following;
- a) the proposed change(s), and a description of the difference to the existing contract requirements;
 - b) a full cost/benefit analysis of the proposed change(s) including a description and estimate of costs (including life cycle costs) the Procuring Entity may incur in implementing the value engineering proposal; and
 - c) a description of any effect(s) of the change on performance/functionality.
- 387 The Procuring Entity may accept the value engineering proposal if the proposal demonstrates benefits that:
- a) accelerate the contract completion period; or
 - b) reduce the Contract Price or the life cycle costs to the Procuring Entity; or
 - c) improve the quality, efficiency, safety or sustainability of the Facilities; or
 - d) yield any other benefits to the Procuring Entity, without compromising the functionality of the Works.
- 388 If the value engineering proposal is approved by the Procuring Entity and results in:
- a) a reduction of the Contract Price; the amount to be paid to the Contractor shall be the **percentage specified in the SCC** of the reduction in the Contract Price; or
 - b) an increase in the Contract Price; but results in a reduction in life cycle costs due to any benefit described in (a) to (d) above, the amount to be paid to the Contractor shall be the full increase in the Contract Price.

39. Cash Flow Forecasts

- 391 When the Program¹¹, is updated, the Contractor shall provide the Project Manager with an updated cash flow forecast. The cash flow forecast shall include different currencies, as defined in the Contract, converted as necessary using the Contract exchange rates.

40. Payment Certificates

- 401 The Contractor shall submit to the Project Manager monthly statements of the estimated value of the work executed less the cumulative amount certified previously.
- 402 The Project Manager shall check the Contractor's monthly statement and certify the amount to be paid to the Contractor.
- 403 The value of work executed shall be determined by the Project Manager.
- 404 The value of work executed shall comprise the value of the quantities of work in the Bill of Quantities that have been completed¹².
- 405 The value of work executed shall include the valuation of Variations and Compensation Events.
- 406 The Project Manager may exclude any item certified in a previous certificate or reduce the proportion of any item previously certified in any certificate in the light of later information.
- 407 Where the contract price is different from the corrected tender price, in order to ensure the contractor is not paid less or more relative to the contract price (which would be the tender price), payment valuation certificates and variation orders on omissions and additions valued based on rates in the Bill of Quantities or schedule of rates in the Tender, will be adjusted by a plus or minus percentage. The percentage already worked out during tender evaluation is worked out as follows: $(\text{corrected tender price} - \text{tender price}) / \text{tender price} \times 100$.

41. Payments

- 41.1 Payments shall be adjusted for deductions for advance payments and retention. The Procuring Entity shall pay the Contractor the amounts certified by the Project Manager within 30 days of the date of each certificate.

If the Procuring Entity makes a late payment, the Contractor shall be paid interest on the late payment in the next payment. Interest shall be calculated from the date by which the payment should have been made up to the date when the late payment is made at the prevailing rate of interest for commercial borrowing for each of the currencies in which payments are made.

- 412 If an amount certified is increased in a later certificate or as a result of an award by the Adjudicator or an Arbitrator, the Contractor shall be paid interest upon the delayed payment as set out in this clause. Interest shall be calculated from the date upon which the increased amount would have been certified in the absence of dispute.
- 413 Unless otherwise stated, all payments and deductions shall be paid or charged in the proportions of currencies comprising the Contract Price.
- 414 Items of the Works for which no rate or price has been entered in shall not be paid for by the Procuring Entity and shall be deemed covered by other rates and prices in the Contract.

42. Compensation Events

421 The following shall be Compensation Events:

- d) The Procuring Entity does not give access to a part of the Site by the Site Possession Date pursuant to GCC Sub-Clause 20.1.
- e) The Procuring Entity modifies the Schedule of Other Contractors in a way that affects the work of the Contractor under the Contract.
- f) The Project Manager orders a delay or does not issue Drawings, Specifications, or instructions required for execution of the Works on time.
- g) The Project Manager instructs the Contractor to uncover or to carry out additional tests upon work, which is then found to have no Defects.
- h) The Project Manager unreasonably does not approve a subcontract to be let.
- i) Ground conditions are substantially more adverse than could reasonably have been assumed before issuance of the Letter of Acceptance from the information issued to bidders (including the Site Investigation Reports), from information available publicly and from a visual inspection of the Site.
- j) The Project Manager gives an instruction for dealing with an unforeseen condition, caused by the Procuring Entity, or additional work required for safety or other reasons.
- k) Other contractors, public authorities, utilities, or the Procuring Entity does not work within the dates and other constraints stated in the Contract, and they cause delay or extra cost to the Contractor.
- l) The advance payment is delayed.
- m) The effects on the Contractor of any of the Procuring Entity's Risks.
- n) The Project Manager unreasonably delays issuing a Certificate of Completion.

422 If a Compensation Event would cause additional cost or would prevent the work being completed before the Intended Completion Date, the Contract Price shall be increased and/or the Intended Completion Date shall be extended. The Project Manager shall decide whether and by how much the Contract Price shall be increased and whether and by how much the Intended Completion Date shall be extended.

423 As soon as information demonstrating the effect of each Compensation Event upon the Contractor's forecast cost has been provided by the Contractor, it shall be assessed by the Project Manager, and the Contract Price shall be adjusted accordingly. If the Contractor's forecast is deemed unreasonable, the Project Manager shall adjust the Contract Price based on the Project Manager's own forecast. The Project Manager shall assume that the Contractor shall react competently and promptly to the event.

¹¹In lump sum contracts, add "or Activity Schedule" after "Program."

¹²In lump sum contracts, replace this paragraph with the following: "The value of work executed shall comprise the value of completed activities in the Activity Schedule."

424 The Contractor shall not be entitled to compensation to the extent that the Procuring Entity's interests are

adversely affected by the Contractor's not having given early warning or not having cooperated with the Project Manager.

43. Tax

- 43.1 The Project Manager shall adjust the Contract Price if taxes, duties, and other levies are changed between the date 30 days before the submission of bids for the Contract and the date of the last Completion certificate. The adjustment shall be the change in the amount of tax payable by the Contractor, provided such changes are not already reflected in the Contract Price or area result of GCC Clause 44.

44. Currency of Payment

- 44.1 All payments under the contract shall be made in Kenya Shillings

45. Price Adjustment

- 45.1 Prices shall be adjusted for fluctuations in the cost of inputs only if **provided for in the SCC**. If so provided, the amounts certified in each payment certificate, before deducting for Advance Payment, shall be adjusted by applying the respective price adjustment factor to the payment amounts due in each currency. A separate formula of the type specified below applies:

$$P = A + B \frac{I_m}{I_o}$$

where: P is the adjustment factor for the portion of the Contract Price payable.

A and B are coefficients¹³ specified in the SCC, representing the non-adjustable and adjustable portions, respectively, of the Contract Price payable and I_m is the index prevailing at the end of the month being invoiced and I_o is the index prevailing 30 days before Bid opening for inputs payable.

- 45.2 If the value of the index is changed after it has been used in a calculation, the calculation shall be corrected and an adjustment made in the next payment certificate. The index value shall be deemed to take account of all changes in cost due to fluctuations in costs.

46. Retention

- 46.1 The Procuring Entity shall retain from each payment due to the Contractor the proportion stated in the SCC until Completion of the whole of the Works.
- 46.2 Upon the issue of a Certificate of Completion of the Works by the Project Manager, in accordance with GCC 53.1, half the total amount retained shall be repaid to the Contractor and half when the Defects Liability Period has passed and the Project Manager has certified that all Defects notified by the Project Manager to the Contractor before the end of this period have been corrected. The Contractor may substitute retention money with an "on demand" Bank guarantee.

47. Liquidated Damages

- 47.1 The Contractor shall pay liquidated damages to the Procuring Entity at the rate per day stated in the SCC for each day that the Completion Date is later than the Intended Completion Date. The total amount of liquidated damages shall not exceed the amount defined in the SCC. The Procuring Entity may deduct liquidated damages from payments due to the Contractor. Payment of liquidated damages shall not affect the Contractor's liabilities.
- 47.2 If the Intended Completion Date is extended after liquidated damages have been paid, the Project Manager shall correct any overpayment of liquidated damages by the Contractor by adjusting the next payment certificate. The Contractor shall be paid interest on the overpayment, calculated from the date of payment to the date of repayment, at the rates specified in GCC Sub-Clause 41.1.

48. Bonus

- 48.1 The Contractor shall be paid a Bonus calculated at the rate per calendar day **stated in the SCC** for each day (less any days for which the Contractor is paid for acceleration) that the Completion is earlier than the Intended Completion Date. The Project Manager shall certify that the Works are complete, although they may not be due to be complete.

49. Advance Payment

- 49.1 The Procuring Entity shall make advance payment to the Contractor of the amounts stated in the SCC by the date stated in the SCC, against provision by the Contractor of an Unconditional Bank Guarantee in a form and by a bank acceptable to the Procuring Entity in amounts and currencies equal to the advance payment.

The Guarantee shall remain effective until the advance payment has been repaid, but the amount of the Guarantee shall be progressively reduced by the amounts repaid by the Contractor. Interest shall not be charged on the advance payment.

- 492 The Contractor is to use the advance payment only to pay for Equipment, Plant, Materials, and mobilization expenses required specifically for execution of the Contract. The Contractor shall demonstrate that advance payment has been used in this way by supplying copies of invoices or other documents to the Project Manager.
- 493 The advance payment shall be repaid by deducting proportionate amounts from payments otherwise due to the Contractor, following the schedule of completed percentages of the Works on a payment basis. No account shall be taken of the advance payment or its repayment in assessing valuations of work done, Variations, price adjustments, Compensation Events, Bonuses, or Liquidated Damages.

50. Securities

- 501 The Performance Security shall be provided to the Procuring Entity no later than the date specified in the Letter of Acceptance and shall be issued in an amount **specified in the SCC**, by a bank or surety acceptable to the Procuring Entity, and denominated in the types and proportions of the currencies in which the Contract Price is payable. The Performance Security shall be valid until a date 28 day from the date of issue of the Certificate of Completion in the case of a Bank Guarantee, and until one year from the date of issue of the Completion Certificate in the case of a Performance Bond.

51. Dayworks

- 511 If applicable, the Dayworks rates in the Contractor's Bid shall be used only when the Project Manager has given written instructions in advance for additional work to be paid for in that way.
- 512 All work to be paid for as Dayworks shall be recorded by the Contractor on forms approved by the Project Manager. Each completed form shall be verified and signed by the Project Manager within two days of the work being done.
- 513 The Contractor shall be paid for Dayworks subject to obtaining signed Dayworks forms.

52. Cost of Repairs

- 521 Loss or damage to the Works or Materials to be incorporated in the Works between the Start Date and the end of the Defects Correction periods shall be remedied by the Contractor at the Contractor's cost if the loss or damage arises from the Contractor's acts or omissions.

E. Finishing the Contract

53. Completion

- 531 The Contractor shall request the Project Manager to issue a Certificate of Completion of the Works, and the Project Manager shall do so upon deciding that the whole of the Works is completed.

54. Taking Over

- 541 The Procuring Entity shall take over the Site and the Works within seven days of the Project Manager's issuing a certificate of Completion.

55. Final Account

- 551 The Contractor shall supply the Project Manager with a detailed account of the total amount that the Contractor considers payable under the Contract before the end of the Defects Liability Period. The Project Manager shall issue a Defects Liability Certificate and certify any final payment that is due to the Contractor within 56 days of receiving the Contractor's account if it is correct and complete. If it is not, the Project Manager shall issue within 56 days a schedule that states the scope of the corrections or additions that are necessary. If the Final Account is still unsatisfactory after it has been resubmitted, the Project Manager shall decide on the amount payable to the Contractor and issue a payment certificate.

¹³The sum of the two coefficients A and B should be 1 (one) in the formula for each currency. Normally, both coefficients shall be the same in the formulae for all currencies, since coefficient A, for the non-adjustable portion of the payments, is a very approximate figure (usually 0.15) to take account of fixed cost elements or other non-adjustable components. The sum of the adjustments for each currency are added to the Contract Price.

56. Operating and Maintenance Manuals

- 561 If “as built” Drawings and/or operating and maintenance manuals are required, the Contractor shall supply them by the dates stated in the SCC.
- 562 If the Contractor does not supply the Drawings and/or manuals by the dates stated in the SCC pursuant to GCC Sub-Clause 56.1, or they do not receive the Project Manager's approval, the Project Manager shall withhold the amount **stated in the SCC** from payments due to the Contractor.

57. Termination

- 571 The Procuring Entity or the Contractor may terminate the Contract if the other party causes a fundamental breach of the Contract.
- 572 Fundamental breaches of Contract shall include, but shall not be limited to, the following:
- a) the Contractor stops work for 30 days when no stoppage of work is shown on the current Program and the stoppage has not been authorized by the Project Manager;
 - b) the Project Manager instructs the Contractor to delay the progress of the Works, and the instruction is not withdrawn within 30 days;
 - c) the Procuring Entity or the Contractor is made bankrupt or goes into liquidation other than for a reconstruction or amalgamation;
 - d) a payment certified by the Project Manager is not paid by the Procuring Entity to the Contractor within 84 days of the date of the Project Manager's certificate;
 - e) the Project Manager gives Notice that failure to correct a particular Defect is a fundamental breach of Contract and the Contractor fails to correct it within a reasonable period of time determined by the Project Manager;
 - f) the Contractor does not maintain a Security, which is required;
 - g) the Contractor has delayed the completion of the Works by the number of days for which the maximum amount of liquidated damages can be paid, as **defined in the SCC**; or
 - h) if the Contractor, in the judgment of the Procuring Entity has engaged in Fraud and Corruption, as defined in paragraph 2.2 a of the Appendix A to the GCC, in competing for or in executing the Contract, then the Procuring Entity may, after giving fourteen (14) days written notice to the Contractor, terminate the Contract and expel him from the Site.
- 573 Notwithstanding the above, the Procuring Entity may terminate the Contract for convenience.
- 574 If the Contract is terminated, the Contractor shall stop work immediately, make the Site safe and secure, and leave the Site as soon as reasonably possible.
- 575 When either party to the Contract gives notice of a breach of Contract to the Project Manager for a cause other than those listed under GCC Sub-Clause 56.2 above, the Project Manager shall decide whether the breach is fundamental or not.

58. Payment upon Termination

- 581 If the Contract is terminated because of a fundamental breach of Contract by the Contractor, the Project Manager shall issue a certificate for the value of the work done and Materials ordered less advance payments received up to the date of the issue of the certificate and less the percentage to apply to the value of the work not completed, as specified in the SCC. Additional Liquidated Damages shall not apply. If the total amount due to the Procuring Entity exceeds any payment due to the Contractor, the difference shall be a debt payable to the Procuring Entity.
- 582 If the Contract is terminated for the Procuring Entity's convenience or because of a fundamental breach of Contract by the Procuring Entity, the Project Manager shall issue a certificate for the value of the work done, Materials ordered, the reasonable cost of removal of Equipment, repatriation of the Contractor's personnel employed solely on the Works, and the Contractor's costs of protecting and securing the Works, and less advance payments received up to the date of the certificate.

59. Property

- 591 All Materials on the Site, Plant, Equipment, Temporary Works, and Works shall be deemed to be the property of the Procuring Entity if the Contract is terminated because of the Contractor's default.

60. Release from Performance

- 60.1 If the Contract is frustrated by the outbreak of war or by any other event entirely outside the control of either the Procuring Entity or the Contractor, the Project Manager shall certify that the Contract has been frustrated. The Contractor shall make the Site safe and stop work as quickly as possible after receiving this certificate and shall be paid for all work carried out before receiving it and for any work carried out afterwards to which a commitment was made.

SECTION IX - SPECIAL CONDITIONS OF CONTRACT

Except where otherwise specified, all Special Conditions of Contract should be filled in by the Procuring Entity prior to issuance of the bidding document. Schedules and reports to be provided by the Procuring Entity should be annexed.

Number of GC Clause	Amendments of, and Supplements to, Clauses in the General Conditions of Contract
A. General	
GCC 1.1 (q)	The Procuring Entity is <i>County Government of Kilifi, P.o Box 519-80108 Kilifi.</i>
GCC 1.1 (u)	The Intended Completion Date for the whole of the Works shall be <i>as per the contract</i>
GCC 1.1 (x)	The Project Manager is <i>Director for Roads, Transport and Public Works, County Government of Kilifi.</i>
GCC 1.1 (z)	The Site is located at <i>Kilifi County</i> and is defined in drawings No. 45
GCC 1.1 (cc)	The Start Date shall be <i>as per the contract</i>
GCC 1.1 (gg)	The Works consist of <i>Recarpeting</i>
GCC 2.2	Sectional Completions are: <i>N/A</i>
GCC 5.1	The Project manager <i>may</i> delegate any of his duties and responsibilities.
GCC 8.1	Schedule of other contractors: <i>N/A</i>
GCC 9.1	<p>Key Personnel GCC 9.1 is replaced with the following:</p> <p>9.1 Key Personnel are the Contractor’s personnel named in this GCC 9.1 of the Special Conditions of Contract. The Contractor shall employ the Key Personnel and use the equipment identified in its Bid, to carry out the Works or other personnel and equipment approved by the Project Manager. The Project Manager shall approve any proposed replacement of Key Personnel and equipment only if their relevant qualifications or characteristics are substantially equal to or better than those proposed in the Bid.</p> <p>[insert the name/s of each Key Personnel agreed by the Procuring Entity prior to Contract signature.]</p>
GCC 13.1	<p>The minimum insurance amounts and deductibles shall be:</p> <ul style="list-style-type: none"> (a) for loss or damage to the Works, Plant and Materials: (b) For loss or damage to Equipment: (c) for loss or damage to property (except the Works, Plant, Materials, and Equipment) in connection with Contract: (d) for personal injury or death: <ul style="list-style-type: none"> (i) of the Contractor’s employees: (ii) of other people:
GCC 14.1	Site Data are:
GCC 20.1	The Site Possession Date(s) shall be: <i>as per the contract</i>

Number of GC Clause	Amendments of, and Supplements to, Clauses in the General Conditions of Contract
GCC 23.1 & GCC 23.2	Appointing Authority for the Adjudicator: PPR.A.
	Hourly rate and types of reimbursable expenses to be paid to the Adjudicator: _____.
B. Time Control	
GCC 26.1	The Contractor shall submit for approval a Program for the Works within 7 days from the date of the Letter of Acceptance.
GCC 26.3	The period between Program updates is <i>14</i> days. The amount to be withheld for late submission of an updated Program is <i>Kshs 5,000</i> .
C. Quality Control	
GCC 34.1	The Defects Liability Period is: <i>84</i> days.
D. Cost Control	
GCC 38.9	If the value engineering proposal is approved by the Procuring Entity the amount to be paid to the Contractor shall be 30% of the reduction in the Contract Price.
GCC 44.1	The currency of the Procuring Entity's Country is: <i>Kenya Shillings</i> .
GCC 45.1	The Contract <i>is not</i> subject to price adjustment in accordance with GCC Clause 45, and the following information regarding coefficients <i>does not</i> apply. <i>[Price adjustment is mandatory for contracts which provide for time of completion exceeding 18 months]</i> The coefficients for adjustment of prices are: (a) ____percent nonadjustable element (coefficient A). <i>N/A</i> (b) ____percent adjustable element (coefficient B). <i>N/A</i> (c) The Index I for shall be <i>N/A</i>
GCC 46.1	The proportion of payments retained is: <i>10%</i>
GCC 47.1	The liquidated damages for the whole of the Works are <i>0.01%</i> per day. The maximum amount of liquidated damages for the whole of the Works is <i>10%</i> of the final Contract Price.
GCC 50.1	The Performance Security amount is <i>10%</i> (a) Performance Security – Bank Guarantee: in the amount(s) of <i>10</i> percent of the Accepted Contract Amount and in the same currency(ies) of the Accepted Contract Amount. (b) Performance Security – Performance Bond: in the amount(s) of <i>10</i> percent of the Accepted Contract Amount and in the same currency(ies) of the Accepted Contract Amount.
E. Finishing the Contract	
GCC 57.2 (g)	The maximum number of days is: <i>28; consistent with Clause 47.1 on liquidated damages</i>].
GCC 58.1	The percentage to apply to the value of the work not completed, representing the Procuring

Number of GC Clause	Amendments of, and Supplements to, Clauses in the General Conditions of Contract
	Entity's additional cost for completing the Works, is <i>10%</i> .

FORM No 1: NOTIFICATION OF INTENTION TO AWARD

This Notification of Intention to Award shall be sent to each Tenderer that submitted a Tender. Send this Notification to the Tenderer's Authorized Representative named in the Tender Information Form on the format below.

FORMAT

1. For the attention of Tenderer's Authorized Representative

i) Name: _____

ii) Address: _____

iii) Telephone: _____

iv) Email Address: _____

2. Date of transmission: _____

This Notification is sent by _____

3. Notification of Intention to Award

i) Procuring Entity: _____

ii) Project: _____

iii) Contract title: _____

iv) Country: _____

v) ITT No: _____

This Notification of Intention to Award (Notification) notifies you of our decision to award the above contract. The transmission of this Notification begins the Standstill Period. During the Standstill Period, you may:

4. Request a debriefing in relation to the evaluation of your tender

Submit a Procurement-related Complaint in relation to the decision to award the contract.

a) The successful tenderer

i) Name of successful Tender _____

ii) Address of the successful Tender _____

iii) Contract price of the successful Tender Kenya Shillings _____ (in words _____)

b) Other Tenderers

Names of all Tenderers that submitted a Tender. If the Tender's price was evaluated include the evaluated price as well as the Tender price as read out. For Tenders not evaluated, give one main reason the Tender was unsuccessful.

SNo	Name of Tender	Tender Price as read out	Tender's evaluated price (Note a)	One Reason Why not Evaluated
1				
2				
3				
4				
5				

(Note a) State NE if not evaluated

5. How to request a debriefing

- a) DEADLINE: The deadline to request a debriefing expires at midnight on _____.
- b) You may request a debriefing in relation to the results of the evaluation of your Tender. If you decide to request a debriefing your written request must be made within three (5) Business Days of receipt of this Notification of Intention to Award.
- c) Provide the contract name, reference number, name of the Tenderer, contact details; and address the request for debriefing as follows:
 - i) Attention: _____
 - ii) Title/position: _____
 - ii) Agency: _____
 - iii) Email address: _____
- d) If your request for a debriefing is received within the 3 Days deadline, we will provide the debriefing within five (3) Business Days of receipt of your request. If we are unable to provide the debriefing within this period, the Standstill Period shall be extended by five (3) Days after the date that the debriefing is provided. If this happens, we will notify you and confirm the date that the extended Standstill Period will end.
- e) The debriefing may be in writing, by phone, video conference call or in person. We shall promptly advise you in writing how the debriefing will take place and confirm the date and time.
- f) If the deadline to request a debriefing has expired, you may still request a debriefing. In this case, we will provide the debriefing as soon as practicable, and normally no later than fifteen (15) Days from the date of publication of the Contract Award Notice.

6. How to make a complaint

- a) Period: Procurement-related Complaint challenging the decision to award shall be submitted by midnight, _____.
- b) Provide the contract name, reference number, name of the Tenderer, contact details; and address the Procurement-related Complaint as follows:
 - i) Attention: _____
 - ii) Title/position: _____
 - iii) Agency: _____
 - iv) Email address: _____
- c) At this point in the procurement process, you may submit a Procurement-related Complaint challenging the decision to award the contract. You do not need to have requested, or received, a debriefing before making this complaint. Your complaint must be submitted within the Standstill Period and received by us before the Standstill Period ends.
- d) Further information: For more information refer to the Public Procurement and Disposals Act 2015 and its Regulations available from the Website info@ppra.go.ke or complaints@ppra.go.ke. You should read these documents before preparing and submitting your complaint.
- e) There are four essential requirements:
 - i) You must be an 'interested party'. In this case, that means a Tenderer who submitted a Tender in this

tendering process, and is the recipient of a Notification of Intention to Award.

- ii) The complaint can only challenge the decision to award the contract.
- iii) You must submit the complaint within the period stated above.
- iv) You must include, in your complaint, all of the information required to support your complaint.

7. Standstill Period

- i) **DEADLINE:** The Standstill Period is due to end at midnight on *[insert date]* (local time).
- ii) The Standstill Period lasts ten (14) Days after the date of transmission of this Notification of Intention to Award.
- iii) The Standstill Period may be extended as stated in paragraph Section 5 (d) above.

If you have any questions regarding this Notification please do not hesitate to contact us. On behalf of the Procuring Entity:

Signature: _____ **Name:** _____

Title/position: _____ **Telephone:** _____ **Email:** _____

FORM NO. 2 - REQUEST FOR REVIEW

FORM FOR REVIEW(r.203(1))

PUBLIC PROCUREMENT ADMINISTRATIVE REVIEW BOARD

APPLICATION NO.....OF.....20.....

BETWEEN

..... **APPLICANT**

AND

..... **RESPONDENT (Procuring Entity)**

Request for review of the decision of the..... (Name of the Procuring Entity ofdated the...day of20.....in the matter of Tender No.....of20..... for..... (Tender description).

REQUEST FOR REVIEW

I/We.....,the above named Applicant(s), of address: Physical address.....P. O. Box No.....Tel. No.....Email, hereby request the Public Procurement Administrative Review Board to review the whole/part of the above mentioned decision on the following grounds , namely:

- 1.
- 2.

By this memorandum, the Applicant requests the Board for an order/orders that:

- 1.
- 2.

SIGNED(Applicant) Dated on.....day of/...20.....

FOR OFFICIAL USE ONLY Lodged with the Secretary Public Procurement Administrative Review Board on day of20.....

SIGNED

Board Secretary

FORM NO 3: LETTER OF AWARD

[letterhead paper of the Procuring Entity] [date]

To: *[name and address of the Contractor]*

This is to notify you that your Tender dated *[date]* for execution of the *[name of the Contract and identification number, as given in the Contract Data]* for the Accepted Contract Amount *[amount in numbers and words] [name of currency]*, as corrected and modified in accordance with the Instructions to Tenderers, is hereby accepted by *(name of Procuring Entity)*.

You are requested to furnish the Performance Security within 30 days in accordance with the Conditions of Contract, using, for that purpose, one of the Performance Security Forms included in Section VIII, Contract Forms, of the Tender Document.

Authorized Signature:.....

Name and Title of Signatory:.....

Name of Procuring Entity.....

Attachment: *Contract Agreement*.....

FORM NO 4: CONTRACT AGREEMENT

THIS AGREEMENT made the _____ day of _____, 20____, between _____ of _____ (hereinafter “the Procuring Entity”), of the one part, and _____ of _____ (hereinafter “the Contractor”), of the other part:

WHEREAS the Procuring Entity desires that the Works known as _____ should be executed by the Contractor, and has accepted a Tender by the Contractor for the execution and completion of these Works and the remedying of any defects therein,

The Procuring Entity and the Contractor agree as follows:

1. In this Agreement words and expressions shall have the same meanings as are respectively assigned to them in the Contract documents referred to.
2. The following documents shall be deemed to form and be read and construed as part of this Agreement. This Agreement shall prevail over all other Contract documents.
 - a) the Letter of Acceptance
 - b) the Letter of Tender
 - c) the addenda Nos _____ (if any)
 - d) the Special Conditions of Contract
 - e) the General Conditions of Contract;
 - f) the Specifications
 - g) the Drawings; and
 - h) the completed Schedules and any other documents forming part of the contract.
3. In consideration of the payments to be made by the Procuring Entity to the Contractor as specified in this Agreement, the Contractor hereby covenants with the Procuring Entity to execute the Works and to remedy defects therein in conformity in all respects with the provisions of the Contract.
4. The Procuring Entity hereby covenants to pay the Contractor in consideration of the execution and completion of the Works and the remedying of defects therein, the Contract Price or such other sum as may become payable under the provisions of the Contract at the times and in the manner prescribed by the Contract.

IN WITNESS whereof the parties hereto have caused this Agreement to be executed in accordance with the Laws of Kenya on the day, month and year specified above.

Signed and sealed by _____ (for the Procuring Entity)

Signed and sealed by _____ (for the Contractor).

FORM NO. 5 - PERFORMANCE SECURITY

[Option 1 - Unconditional Demand Bank Guarantee]

[Guarantor letterhead]

Beneficiary: _____ **Date:** _____

Guarantor: _____

1. We have been informed that _____ (hereinafter called "the Contractor") has entered into Contract No. _____ dated _____ with (name of Procuring Entity) _____ (the Procuring Entity as the Beneficiary), for the execution of _____ (hereinafter called "the Contract").
2. Furthermore, we understand that, according to the conditions of the Contract, a performance guarantee is required.
3. At the request of the Contractor, we as Guarantor, hereby irrevocably undertake to pay the Beneficiary any sum or sums not exceeding in total an amount of _____ (in words),¹ such sum being payable in the types and proportions of currencies in which the Contract Price is payable, upon receipt by us of the Beneficiary's complying demand supported by the Beneficiary's statement, whether in the demand itself or in a separate signed document accompanying or identifying the demand, stating that the Applicant is in breach of its obligation(s) under the Contract, without the Beneficiary needing to prove or to show grounds for your demand or the sums specified therein.
4. This guarantee shall expire, no later than the Day of, 2², and any demand for payment under it must be received by us at the office indicated above on or before that date.
5. The Guarantor agrees to a one-time extension of this guarantee for a period not to exceed [six months][one year], in response to the Beneficiary's written request for such extension, such request to be presented to the Guarantor before the expiry of the guarantee."

[Name of Authorized Official, signature(s) and seals/stamps].

¹The Guarantor shall insert an amount representing the percentage of the Accepted Contract Amount specified in the Letter of Acceptance, less provisional sums, if any, and denominated either in the currency of the Contract or a freely convertible currency acceptable to the Beneficiary.

²Insert the date twenty-eight days after the expected completion date as described in GC Clause 11.9. The Procuring Entity should note that in the event of an extension of this date for completion of the Contract, the Procuring Entity would need to request an extension of this guarantee from the Guarantor. Such request must be in writing and must be made prior to the expiration date established in the guarantee.

FORM No. 6 - PERFORMANCE SECURITY

[Option 2- Performance Bond]

[Guarantor letterhead or SWIFT identifier code]

Beneficiary: _____ **Procuring Entity/ Date:** _____.

PERFORMANCE BOND No.: _____

Guarantor: _____

1. By this Bond _____ as Principal (hereinafter called "the Contractor") and _____] as Surety (hereinafter called "the Surety"), are held and firmly bound unto _____] as Obligee (hereinafter called "the Procuring Entity") in the amount of _____ for the payment of which sum well and truly to be made in the types and proportions of currencies in which the Contract Price is payable, the Contractor and the Surety bind themselves, their heirs, executors, administrators, successors and assigns, jointly and severally, firmly by these presents.
2. WHEREAS the Contractor has entered into a written Agreement with the Procuring Entity dated the _____ day of _____, 20 , for _____ in accordance with the documents, plans, specifications, and amendments thereto, which to the extent herein provided for, are by reference made part hereof and are hereinafter referred to as the Contract.
3. NOW, THEREFORE, the Condition of this Obligation is such that, if the Contractor shall promptly and faithfully perform the said Contract (including any amendments thereto), then this obligation shall be null and void; otherwise, it shall remain in full force and effect. Whenever the Contractor shall be, and declared by the Procuring Entity to be, in default under the Contract, the Procuring Entity having performed the Procuring Entity's obligations thereunder, the Surety may promptly remedy the default, or shall promptly:
 - 1) complete the Contract in accordance with its terms and conditions; or
 - 2) obtain a tender or tenders from qualified tenderers for submission to the Procuring Entity for completing the Contract in accordance with its terms and conditions, and upon determination by the Procuring Entity and the Surety of the lowest responsive Tenderers, arrange for a Contract between such Tenderer, and Procuring Entity and make available as work progresses (even though there should be a default or a succession of defaults under the Contract or Contracts of completion arranged under this paragraph) sufficient funds to pay the cost of completion less the Balance of the Contract Price; but not exceeding, including other costs and damages for which the Surety may be liable hereunder, the amount set forth in the first paragraph hereof. The term "Balance of the Contract Price," as used in this paragraph, shall mean the total amount payable by Procuring Entity to Contractor under the Contract, less the amount properly paid by Procuring Entity to Contractor; or
 - 3) pay the Procuring Entity the amount required by Procuring Entity to complete the Contract in accordance with its terms and conditions up to a total not exceeding the amount of this Bond.
4. The Surety shall not be liable for a greater sum than the specified penalty of this Bond.
5. Any suit under this Bond must be instituted before the expiration of one year from the date of the issuing of the Taking-Over Certificate. No right of action shall accrue on this Bond to or for the use of any person or corporation other than the Procuring Entity named herein or the heirs, executors, administrators, successors, and assigns of the Procuring Entity.
6. In testimony whereof, the Contractor has hereunto set his hand and affixed his seal, and the Surety has caused these presents to be sealed with his corporate seal duly attested by the signature of his legal representative, this day _____ of _____ 20 _____.

SIGNED ON _____ on behalf of By ___ in the capacity of In the presence of

SIGNED ON _____ on behalf of By ___ in the capacity of In the presence of

FORM NO. 7 - ADVANCE PAYMENT SECURITY

[Demand Bank Guarantee]

Beneficiary: _____

Date: _____

ADVANCE PAYMENT GUARANTEE No.: _____ **Guarantor:** _____

1. We have been informed that _____ (hereinafter called "the Contractor") has entered into Contract No. _____ dated _____ with the Beneficiary, for the execution of _____ (hereinafter called "the Contract").
2. Furthermore, we understand that, according to the conditions of the Contract, an advance payment in the sum _____ (in words) is to be made against an advance payment guarantee.
3. At the request of the Contractor, we as Guarantor, hereby irrevocably undertake to pay the Beneficiary any sum or sums not exceeding in total an amount of _____ (in words _____)¹ upon receipt by us of the Beneficiary's complying demand supported by the Beneficiary's statement, whether in the demand itself or in a separate signed document accompanying or identifying the demand, stating either that the Applicant:
 - a) has used the advance payment for purposes other than the costs of mobilization in respect of the Works; or
 - b) has failed to repay the advance payment in accordance with the Contract conditions, specifying the amount which the Applicant has failed to repay.
4. A demand under this guarantee may be presented as from the presentation to the Guarantor of a certificate from the Beneficiary's bank stating that the advance payment referred to above has been credited to the Contractor on its account number _____ at _____.
5. The maximum amount of this guarantee shall be progressively reduced by the amount of the advance payment repaid by the Contractor as specified in copies of interim statements or payment certificates which shall be presented to us. This guarantee shall expire, at the latest, upon our receipt of a copy of the interim payment certificate indicating that ninety (90) percent of the Accepted Contract Amount, less provisional sums, has been certified for payment, or on the ___ day of _____, 2,² whichever is earlier. Consequently, any demand for payment under this guarantee must be received by us at this office on or before that date.
6. The Guarantor agrees to a one-time extension of this guarantee for a period not to exceed *six months*, in response to the Beneficiary's written request for such extension, such request to be presented to the Guarantor before the expiry of the guarantee.

[Name of Authorized Official, signature(s) and seals/stamps]

¹The Guarantor shall insert an amount representing the amount of the advance payment and denominated either in the currency of the advance payment as specified in the Contract.

²Insert the expected expiration date of the Time for Completion. The Procuring Entity should note that in the event of an extension of the time for completion of the Contract, the Procuring Entity would need to request an extension of this guarantee from the Guarantor. Such request must be in writing and must be made prior to the expiration date established in the guarantee

FORM NO. 8 - RETENTION MONEY SECURITY

[Demand Bank Guarantee]

Beneficiary: _____

Date: _____

Advance payment guarantee no. _____

Guarantor: _____

1. We have been informed that _____ (hereinafter called "the Contractor") has entered into Contract No. _____ dated _____ with the Beneficiary, for the execution of _____ (hereinafter called "the Contract").
2. Furthermore, we understand that, according to the conditions of the Contract, the Beneficiary retains moneys up to the limit set forth in the Contract ("the Retention Money"), and that when the Taking-Over Certificate has been issued under the Contract and the first half of the Retention Money has been certified for payment, and payment of [insert thesecond half of the Retention Money] is to be madeagainst a Retention Money guarantee.
3. At the request of the Contractor, we, as Guarantor, hereby irrevocably undertake to pay the Beneficiary any sum or sums not exceeding in total an amount of [insert amount in figures] _____ ([insert amount in words J])¹ upon receipt by us of the Beneficiary's complying demand supported by the Beneficiary's statement, whether in the demand itself or in a separate signed document accompanying or identifying the demand, stating that the Contractor is in breach of its obligation(s) under the Contract, without your needing to prove or show grounds for your demand or the sum specified therein.
4. A demand under this guarantee may be presented as from the presentation to the Guarantor of a certificate from the Beneficiary's bank stating that the second half of the Retention Money as referred to above has been credited to the Contractor on its accou nt number _____ at _____ [insert name and address of Applicant's bank].
5. This guarantee shall expire no later than the Day of, 2.....², and any demand for payment under it must bereceived by us at the office indicated above on or beforethat date.
6. The Guarantor agrees to a one-time extension of this guarantee for a period not to exceed [six months] [one year], in response to the Beneficiary's written request for such extension, such request to be presented to the Guarantor before the expiry of theguarantee.

[Name of Authorized Official, signature(s) and seals/stamps]

¹The Guarantor shall insert an amount representing the amount of the second half of the Retention Money.

²Insert a date that is twenty-eight days after the expiry of retention period after the actual completion date of the contract. The Procuring Entity should note that in the event of an extension of this date for completion of the Contract, the Procuring Entity would need to request an extension of this guarantee from the Guarantor. Such request must be in writing and must be made prior to the expiration date established in the guarantee.

FORM NO. 9 BENEFICIAL OWNERSHIP DISCLOSURE FORM**INSTRUCTIONS TO TENDERERS: DELETE THIS BOX ONCE YOU HAVE COMPLETED THE FORM**

This Beneficial Ownership Disclosure Form ("Form") is to be completed by the successful tenderer. In case of joint venture, the tenderer must submit a separate Form for each member. The beneficial ownership information to be submitted in this Form shall be current as of the date of its submission.

For the purposes of this Form, a Beneficial Owner of a Tenderer is any natural person who ultimately owns or controls the Tenderer by meeting one or more of the following conditions:

- *Directly or indirectly holding 25% or more of the shares.*
- *Directly or in directly holding 25% or more of the voting rights.*
- *Directly or indirectly having the right to appoint a majority of the board of directors or equivalent governing body of the Tenderer.*

Tender Reference No.: _____

Name of the Assignment: _____

to: _____

In response to your notification of award dated _____ to furnish additional information on beneficial ownership: _____

I) We hereby provide the following beneficial ownership information.

Details of beneficial ownership

Identity of Beneficial Owner	Directly or indirectly holding 25% or more of the shares (Yes / No)	Directly or indirectly holding 25 % or more of the Voting Rights (Yes / No)	Directly or indirectly having the right to appoint a majority of the board of the directors or an equivalent governing body of the Tenderer (Yes / No)
<i>[include full name (last, middle, first), nationality, country of residence]</i>			

OR

ii) We declare that there is no Beneficial Owner meeting one or more of the following conditions: directly or indirectly holding 25% or more of the shares. Directly or indirectly holding 25% or more of the voting rights. Directly or indirectly having the right to appoint a majority of the board of directors or equivalent governing body of the Tenderer.

OR

We declare that we are unable to identify any Beneficial Owner meeting one or more of the following conditions. [If this option is selected, the Tenderer shall provide explanation on why it is unable to identify any Beneficial Owner]

Directly or indirectly holding 25% or more of the shares. Directly or indirectly holding 25% or more of the voting rights.

Directly or indirectly having the right to appoint a majority of the board of directors or equivalent governing body of the Tenderer]"

Name of the Tenderer *[insert complete name of the Tenderer] _____

Name of the person duly authorized to sign the Tender on behalf of the Tenderer: ** [insert complete name of person duly authorized to sign the Tender]

Title of the person signing the Tender:

Signature of the person named above Date

signed day of.....